

<SUPPLEMENT-V>

# SYSTEME DE GESTION MOTEUR

## SECTION **EC**

### AVIS DE MODIFICATION :

Les schémas de câblage ont été modifiés.

EC

## TABLE DES MATIERES

|  |                 |                          |
|--|-----------------|--------------------------|
| <input type="checkbox"/>   | <b>ZD30DDTi</b> | <input type="checkbox"/> |
| <b>SYSTEME GENERAL DE GESTION MOTEUR ET DE CONTROLE ANTIPOLLUTION</b> ..... 5002 |                 |                          |
| Schéma du circuit..... 5002  |                 |                          |
| <b>DTC 0102 DEBITMETRE AIR</b> ..... 5003  |                 |                          |
| Schéma de câblage..... 5003  |                 |                          |
| <b>DTC 0103 CAP TEMP MOTEUR</b> ..... 5004                                       |                 |                          |

|                                      |      |
|--------------------------------------|------|
| Schéma de câblage.....               | 5004 |
| <b>DTC 0504 LIGNE COM T/A</b> .....  | 5005 |
| Schéma de câblage.....               | 5005 |
| <b>DTC 0905 PRESSION TURBO</b> ..... | 5006 |
| Schéma de câblage.....               | 5006 |
| <b>MANOCONTACT D'HUILE</b> .....     | 5007 |
| Schéma de câblage.....               | 5007 |



Schéma de câblage

EC-MAFS-01



Schéma de câblage

EC-ECTS-01

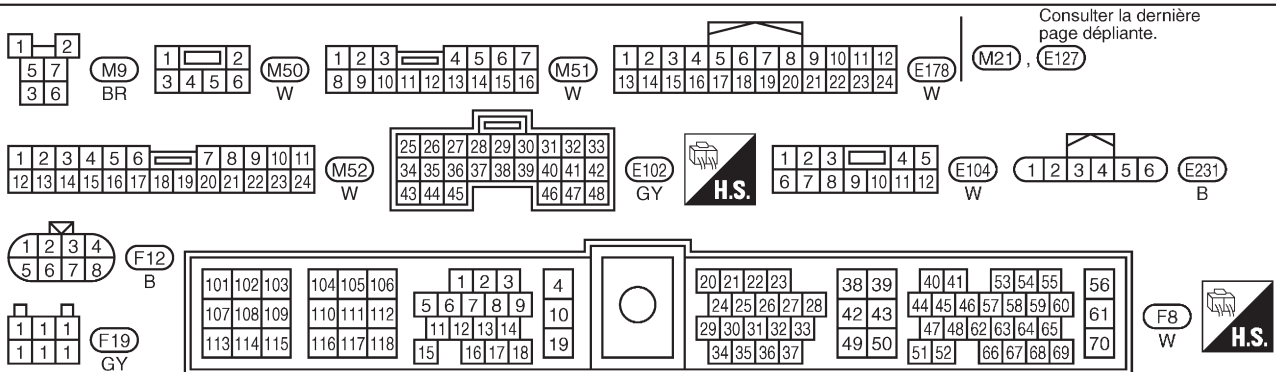
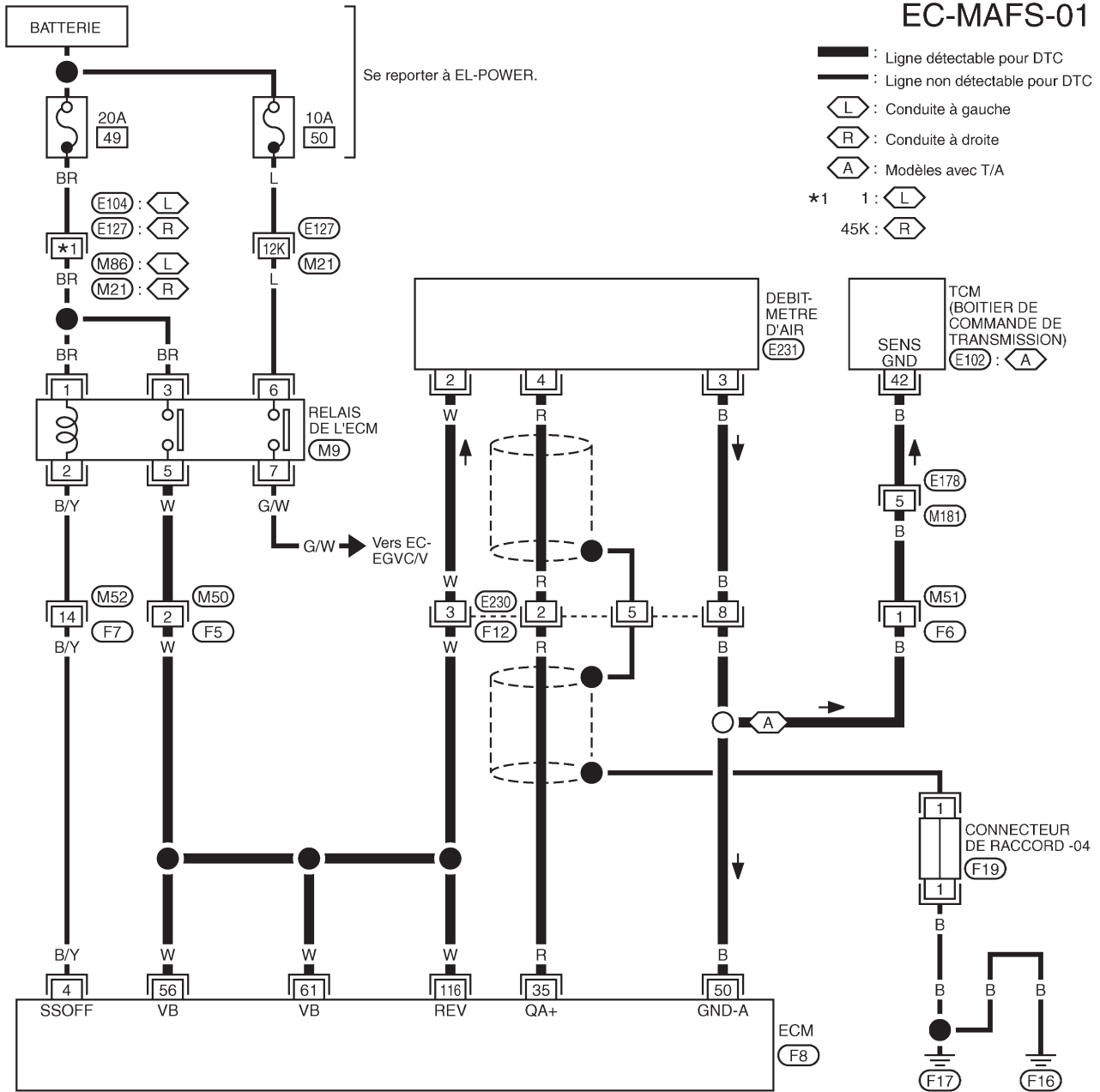

Schéma de câblage

EC-AT/C-01

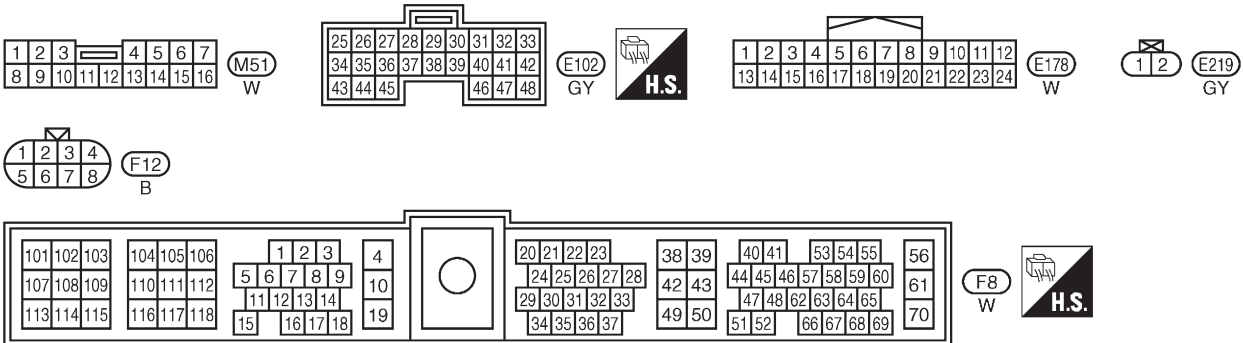
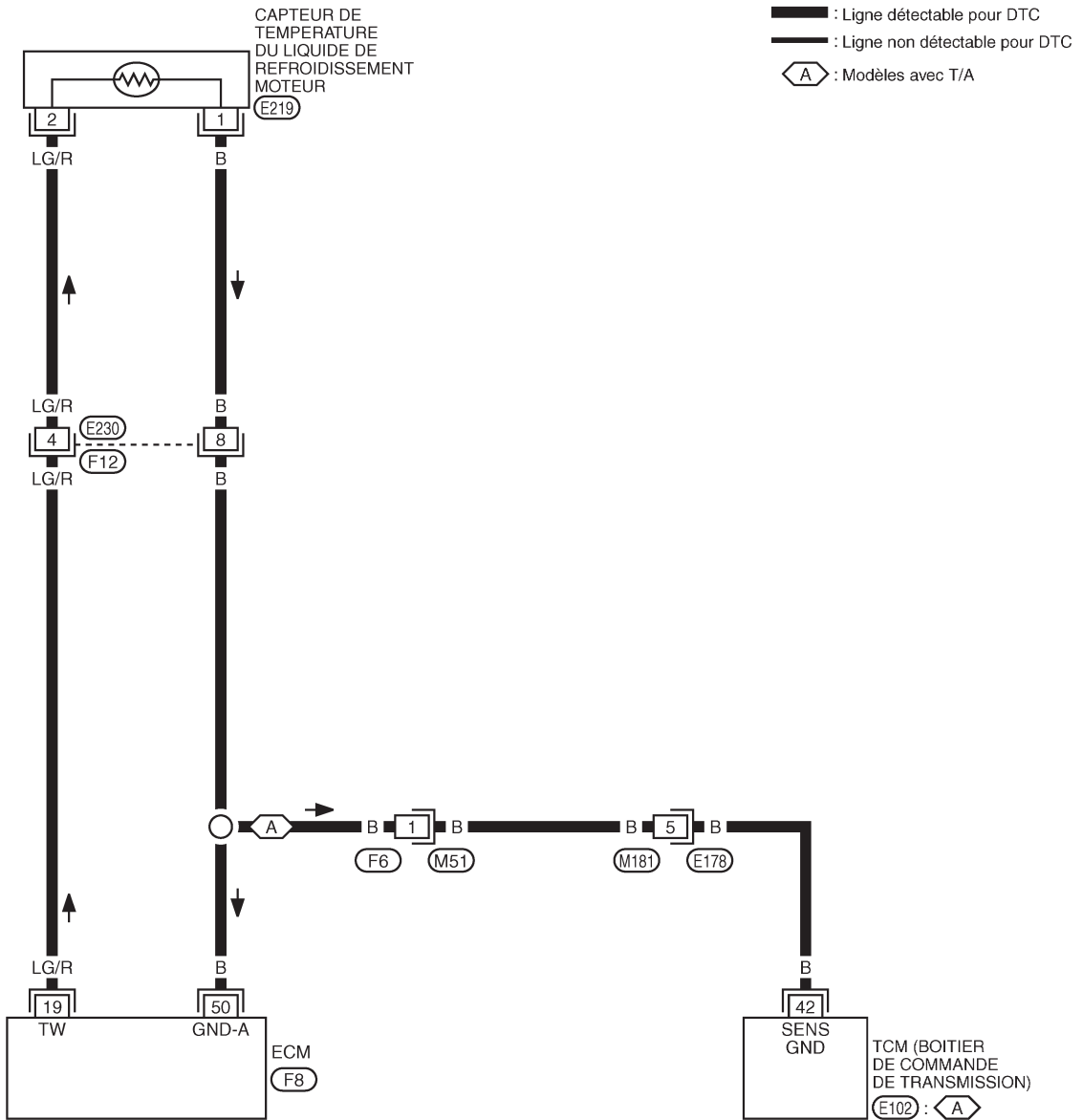

Schéma de câblage

EC-BOOST-01

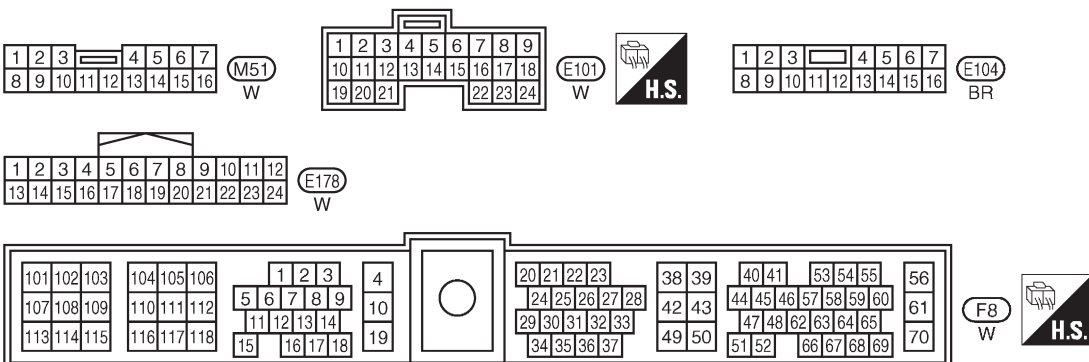
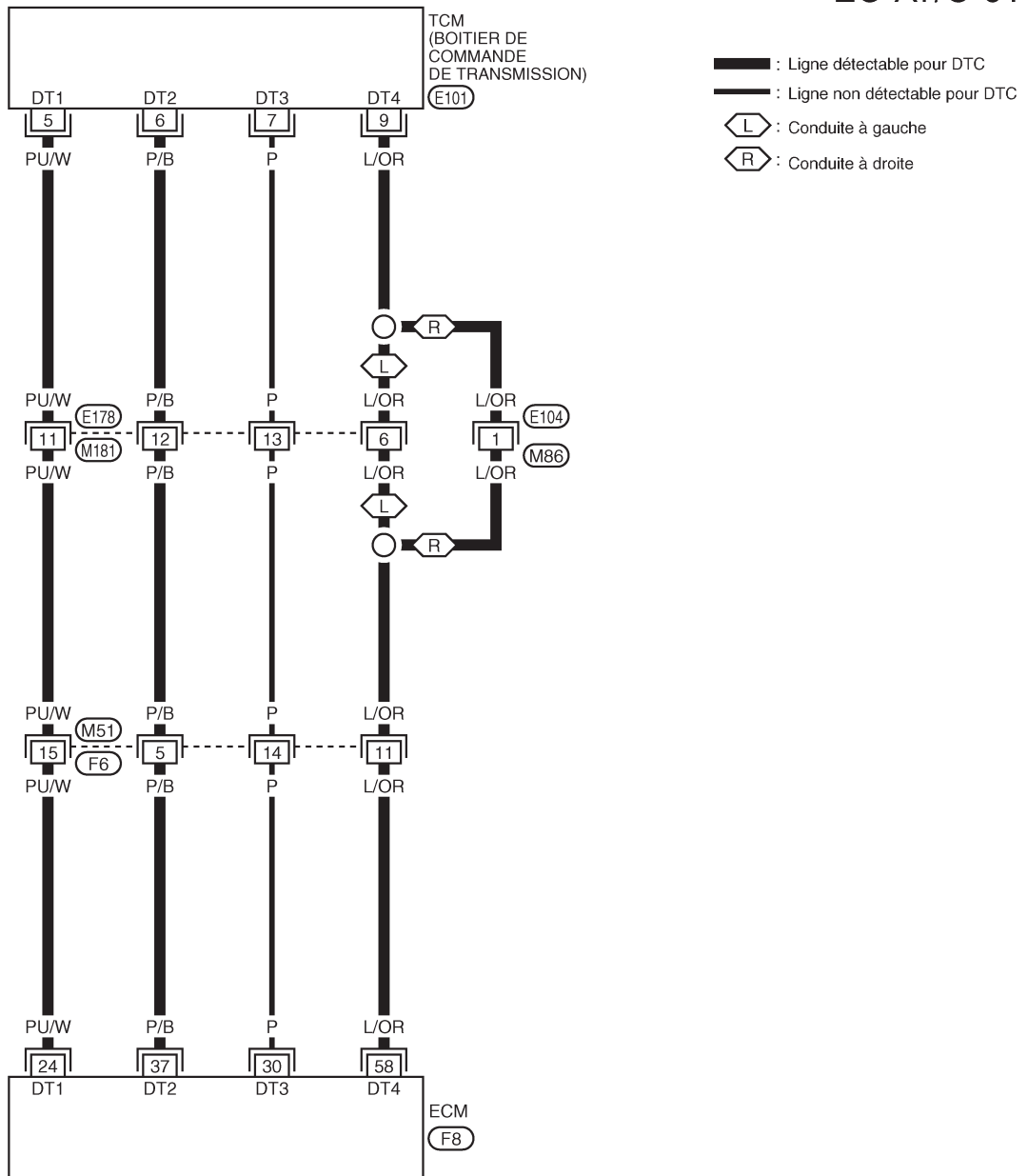

Schéma de câblage

EC-OILP/W-01

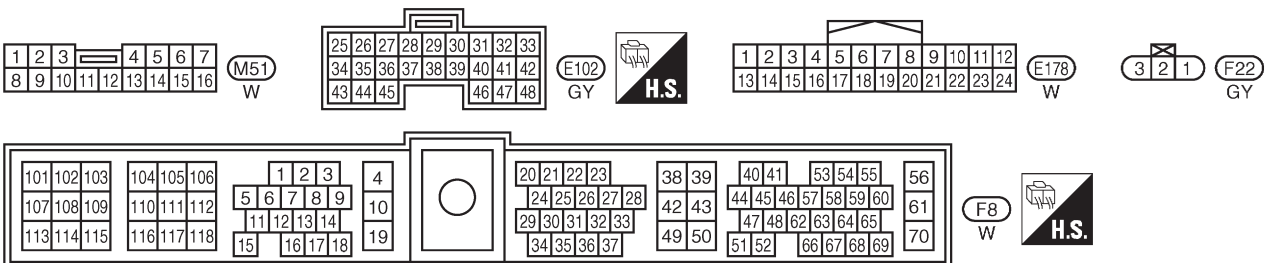
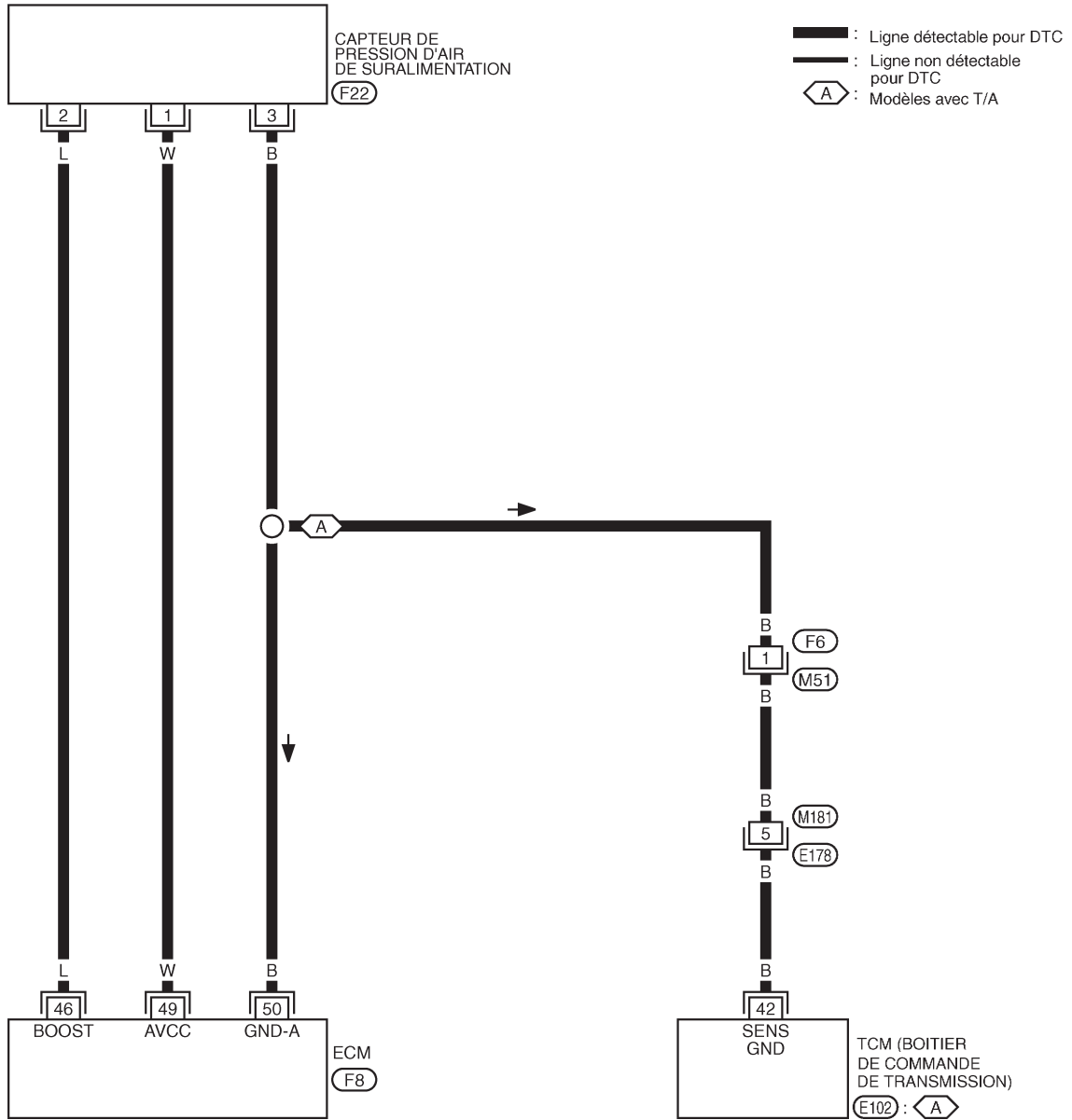
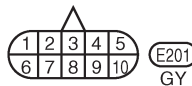
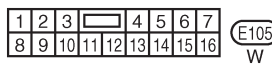
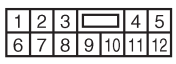
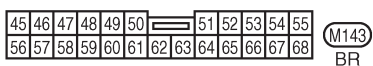
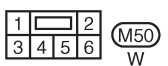
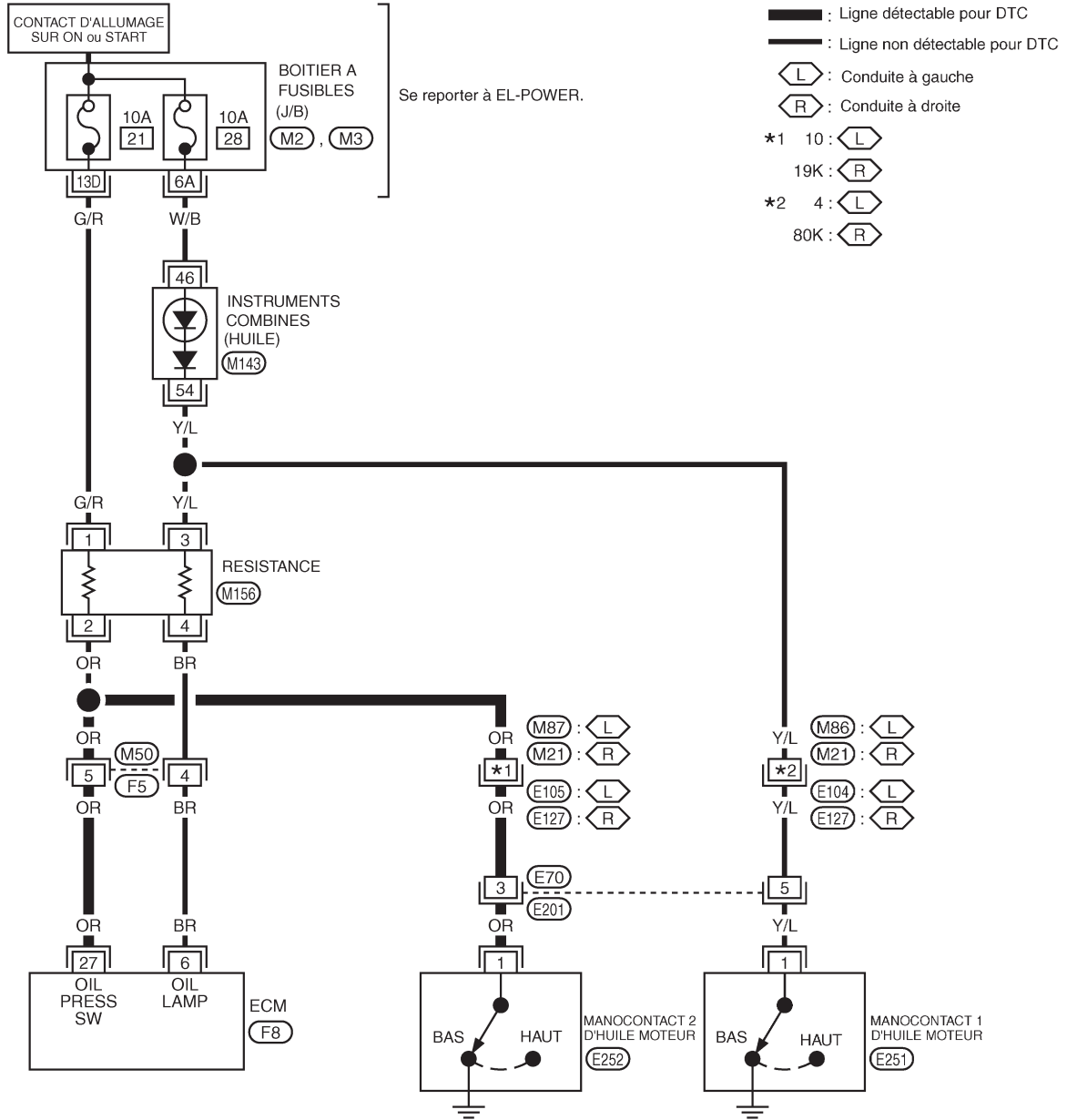

Consulter la dernière page dépliant.

- (M21), (E127)
- (M2)
- (M3)

