

<SUPPLEMENT-V>

SYSTEME DE FREINAGE

SECTION **BR**

AVIS DE MODIFICATION :

Les schémas de câblage ont été modifiés.

TABLE DES MATIERES

DIAGNOSTIC DES DEFAUTS	5002	Schéma de câblage - ABS -	5003
Schéma	5002		

DIAGNOSTIC DES DEFAUTS

Schéma

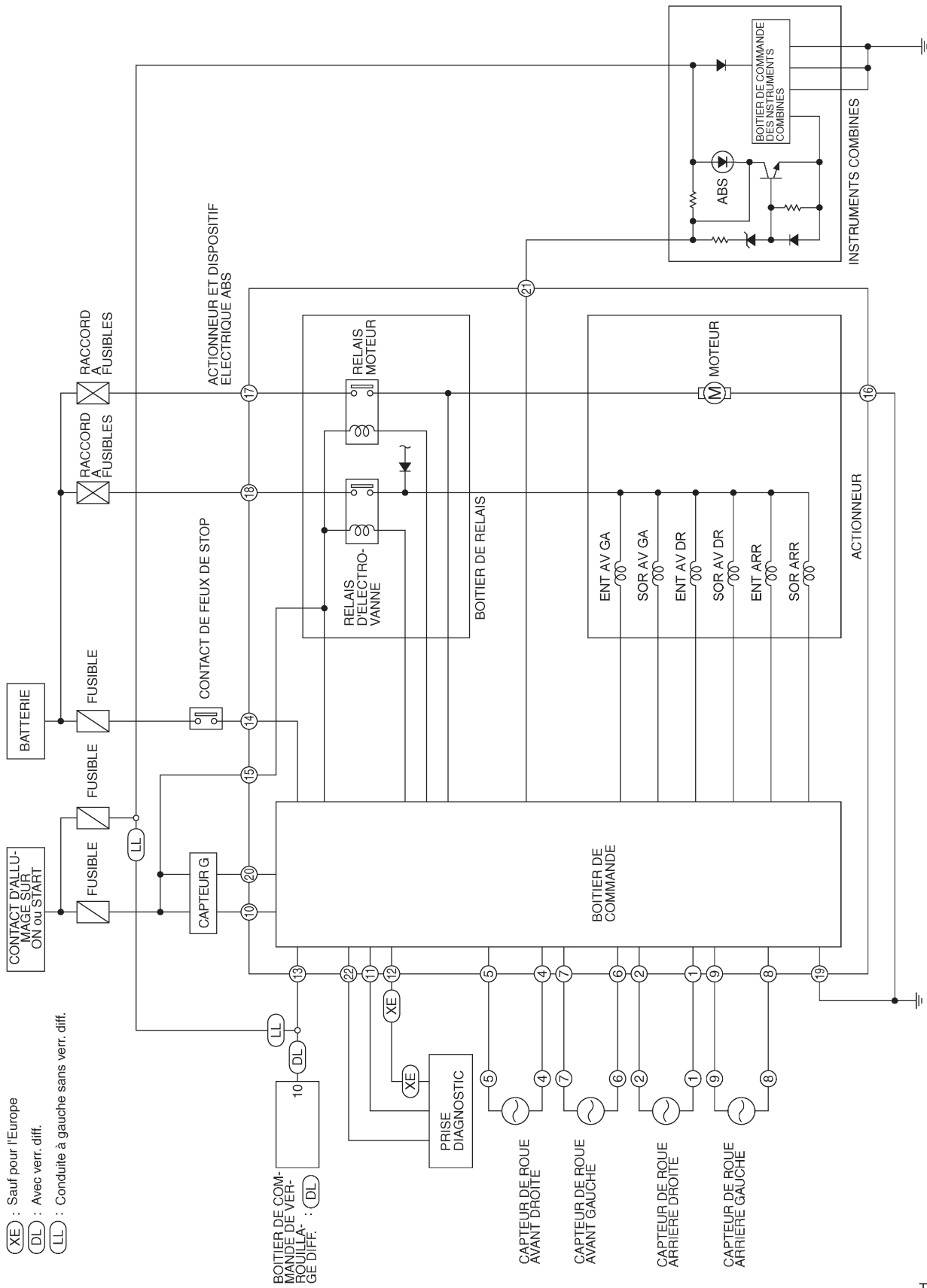

TBR052M

DIAGNOSTIC DES DEFAUTS

Schéma de câblage — ABS —

BR-ABS-01

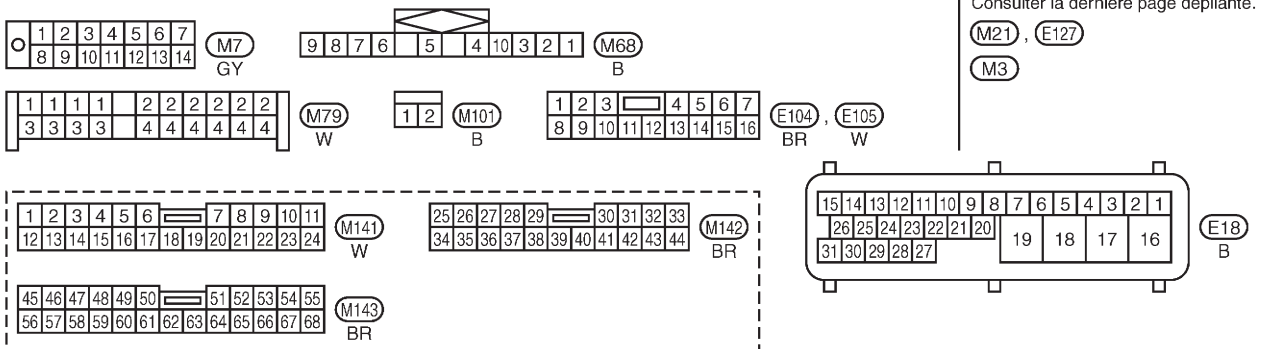
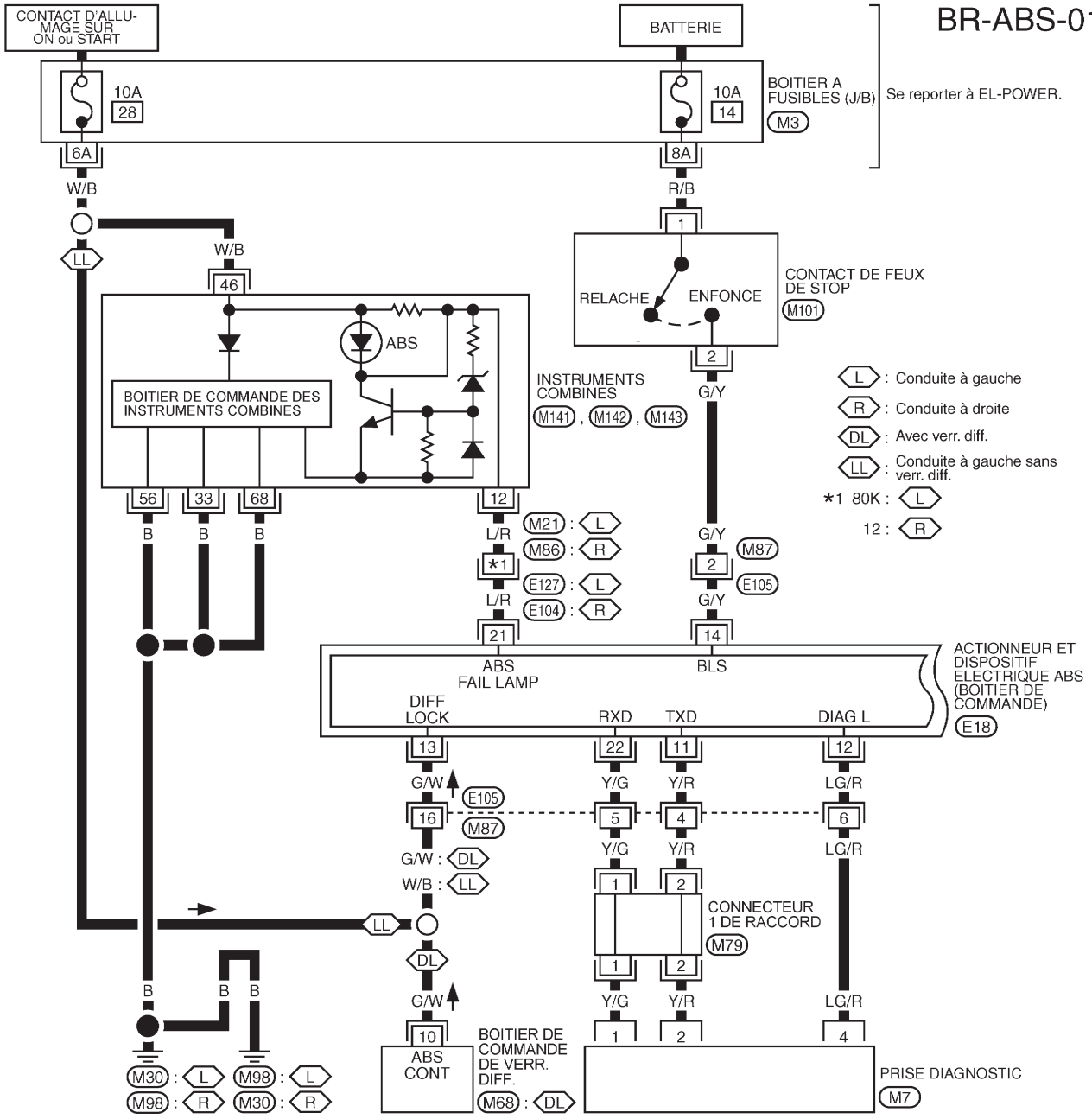

TBR042M

DIAGNOSTIC DES DEFAUTS

Schéma de câblage — ABS — (Suite)

BR-ABS-02

Se reporter à EL-POWER.

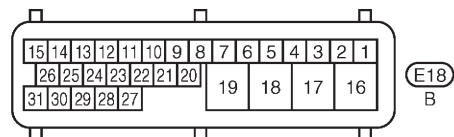
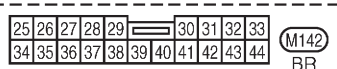
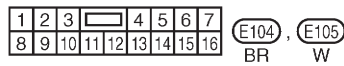
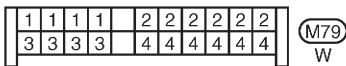
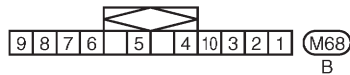
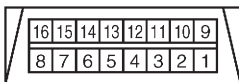
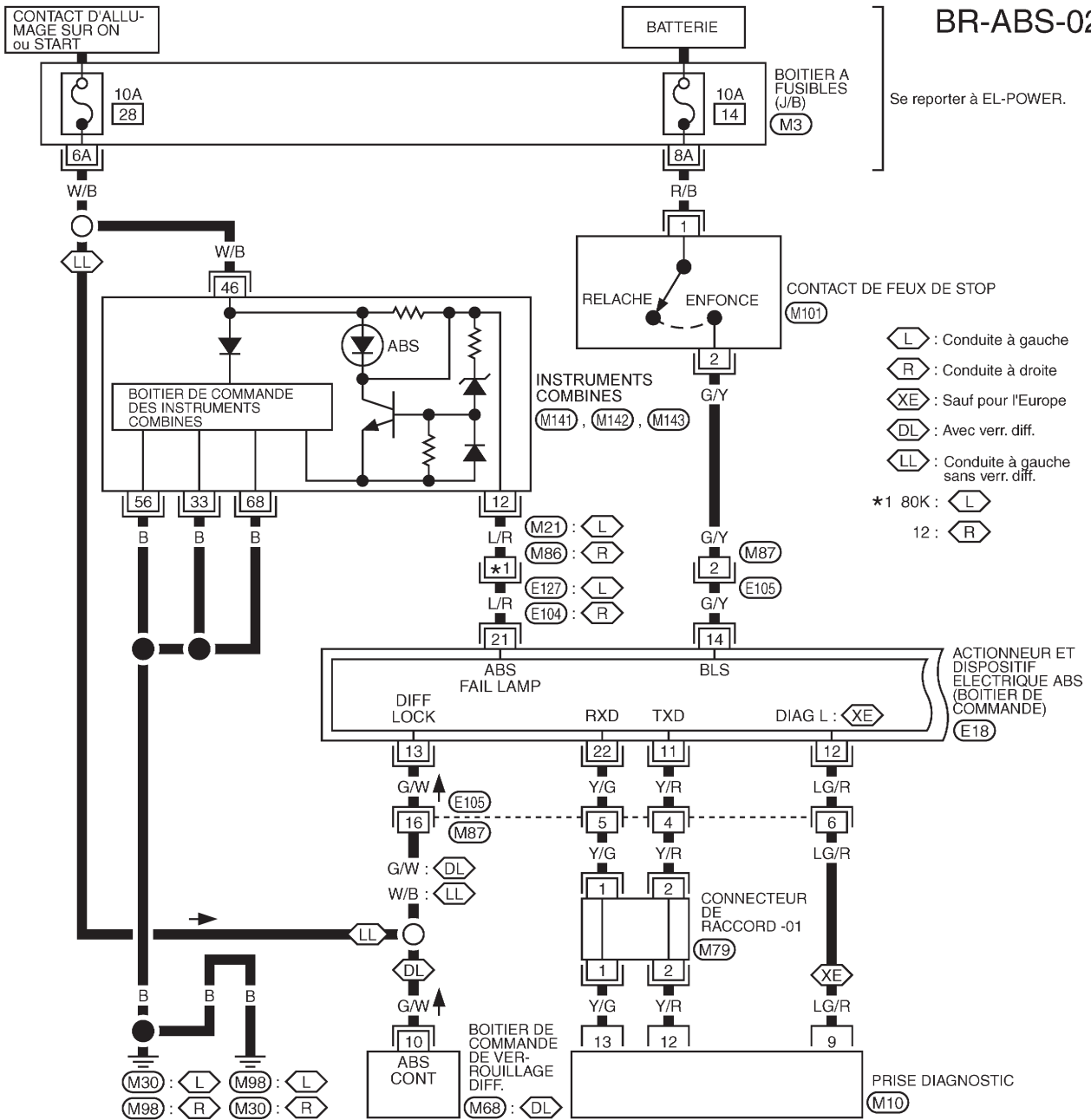

Consulter la dernière page dépliante

M21, E127
M3

DIAGNOSTIC DES DEFAUTS

Schéma de câblage — ABS — (Suite)

BR-ABS-03

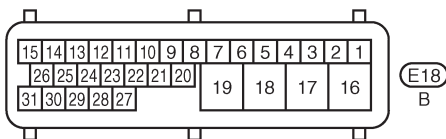
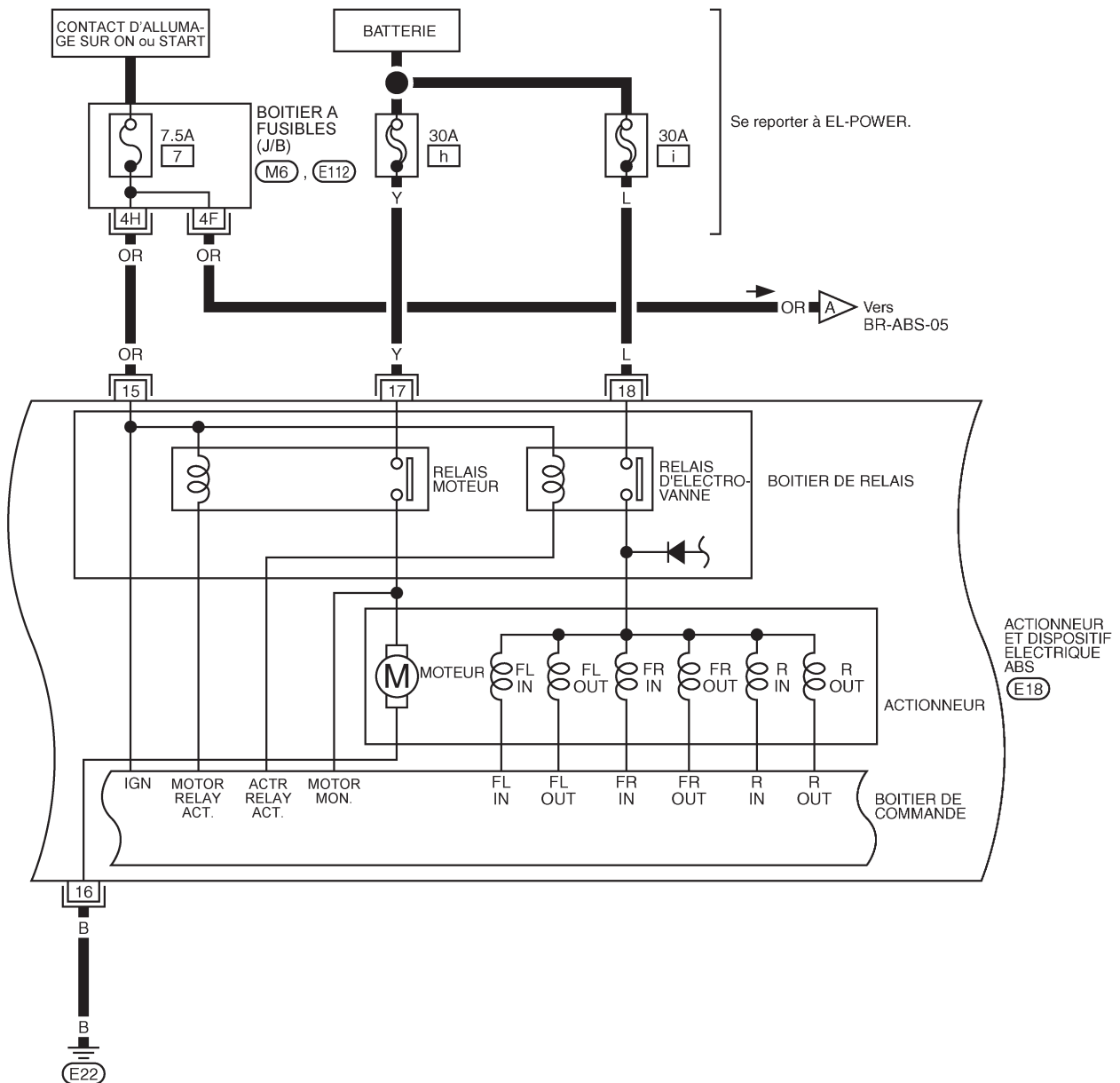

Consulter la dernière page dépliant.

M6

E112

TBR053M

DIAGNOSTIC DES DEFAUTS

Schéma de câblage — ABS — (Suite)

BR-ABS-04

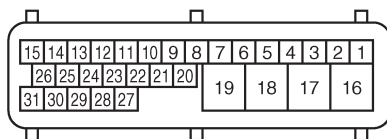
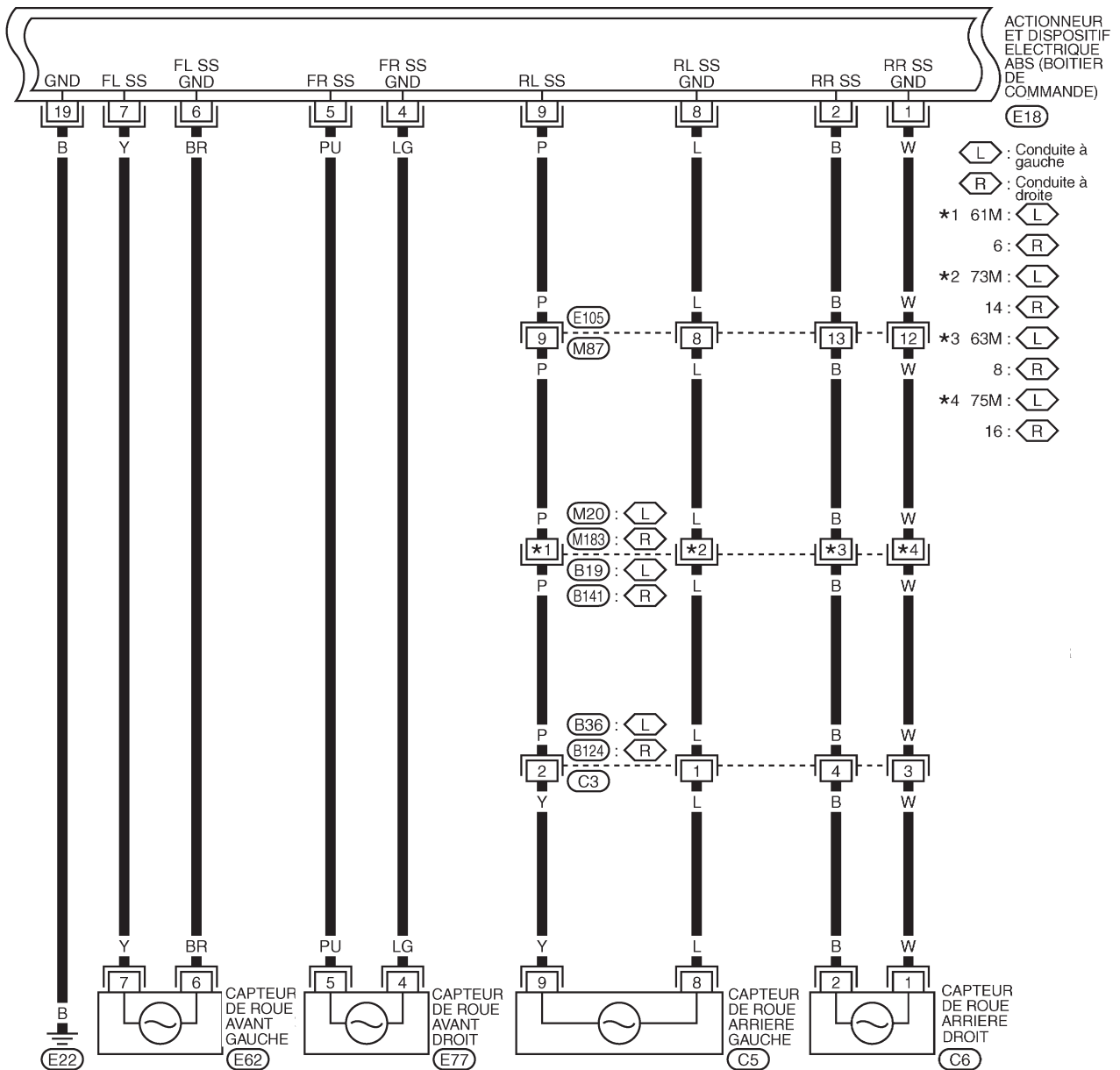

(E18)
B

(7) (6)
E62
BR

(5) (4)
E77
GY

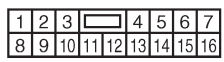

(E105)
W

(9) (8)
C5
BR

(2) (1)
C6
GY

(1) (2)
(3) (4)
B36, B124
SB, SB

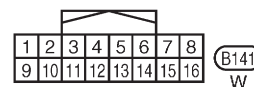

(B141)
W

Consulter la dernière page dépliante.

(M20), (B19)

TBR066M

DIAGNOSTIC DES DEFAUTS

Schéma de câblage — ABS — (Suite)

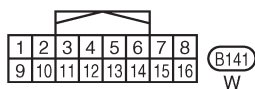
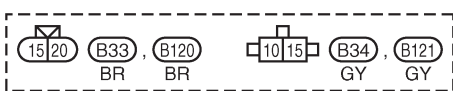
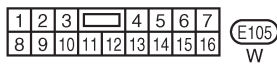
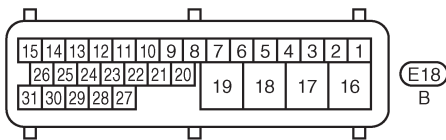
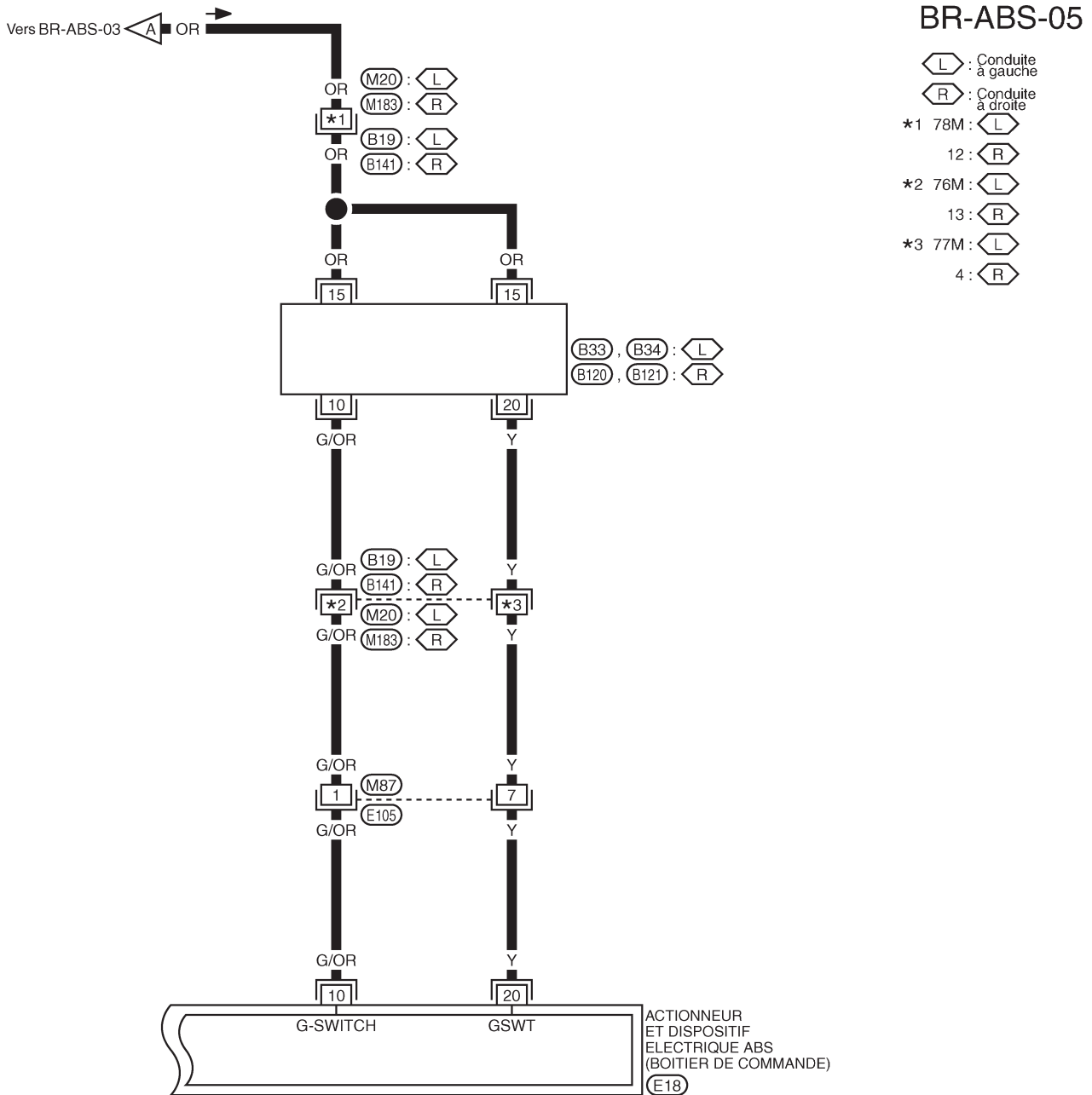

Consulter la dernière page dépliant.

(M20), (B19)