

BOITE DE VITESSES AUTOMATIQUE

SECTION AT

AVIS DE MODIFICATION :

- Les schémas de câblages ont été modifiés.

TABLE DES MATIERES

<input type="checkbox"/>	RE4R03A	<input type="checkbox"/>
PRESENTATION GENERALE DU SYSTEME	5002	
Schéma du circuit	5002	
Schéma de câblage - A/T -	5003	
DIAGNOSTIC DES DEFAUTS - Système de verrouillage de T/A	5011	
Schéma de câblage - SHIFT -	5011	
<input type="checkbox"/>	RE5R05A	<input type="checkbox"/>
DIAGNOSTIC DES DEFAUTS	5012	
Schéma du circuit	5012	
DTC P0615 CIRCUIT DU SIGNAL DE DEMARRAGE	5013	

Schéma de câblage - AT - STSIG	5013
DTC P1701 BOITIER DE COMMANDE DE TRANSMISSION (ALIMENTATION ELECTRIQUE)	5014
Schéma de câblage - AT - POWER	5014
DTC P1815 COMMANDE DE MODE MANUEL	5016
Schéma de câblage - AT - MMSW	5016
DIAGNOSTIC DES DEFAUTS POUR LES SYMPTOMES	5017
Schéma de câblage - AT - NONDTC	5017
SYSTEME DE VERROUILLAGE DE T/A	5019
Schéma de câblage - SHIFT -	5019

Schéma du circuit

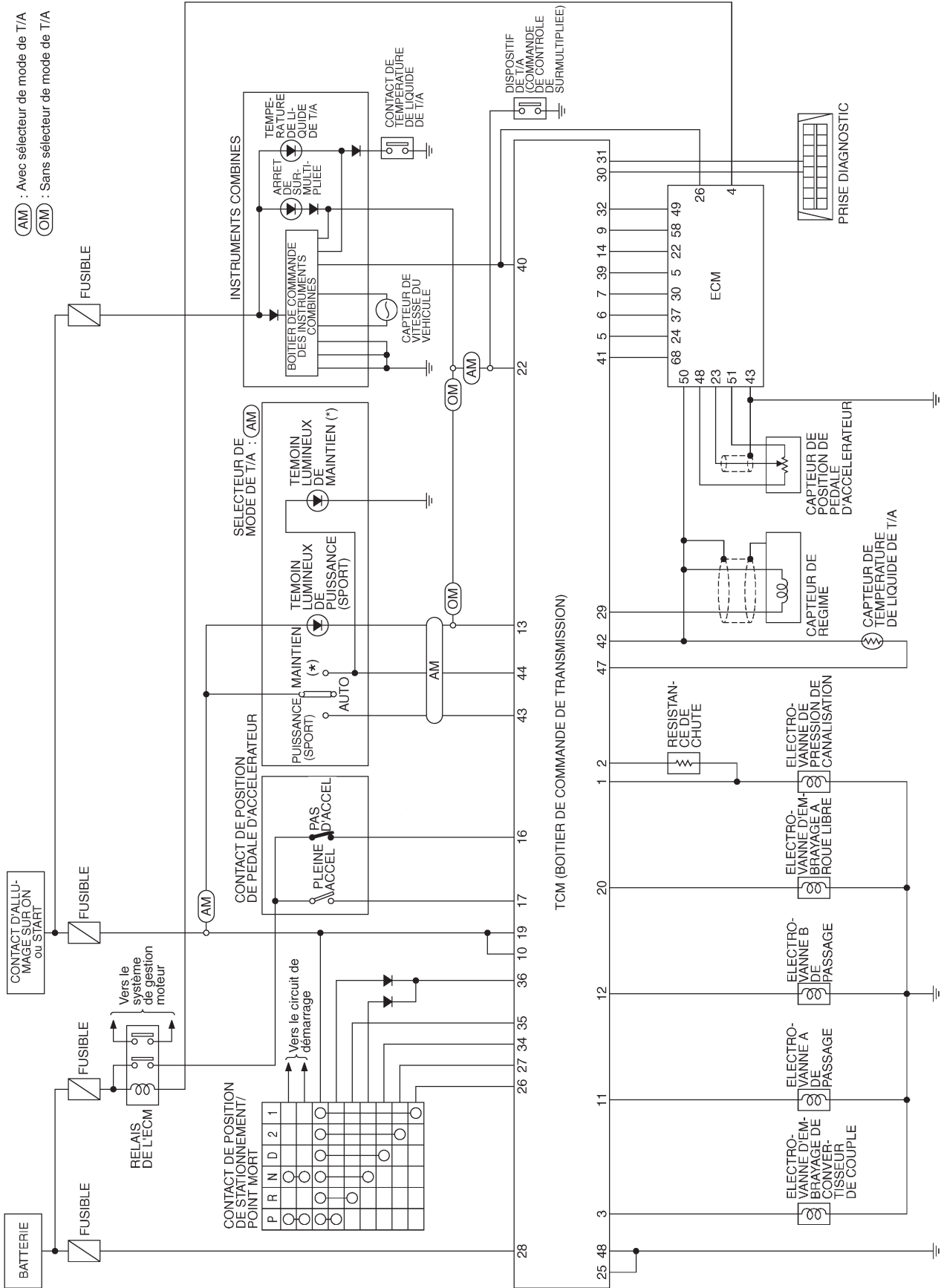

TAT160M

Schéma de câblage — A/T —

AT-A/T-01

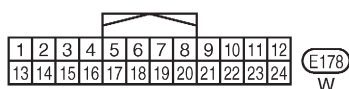
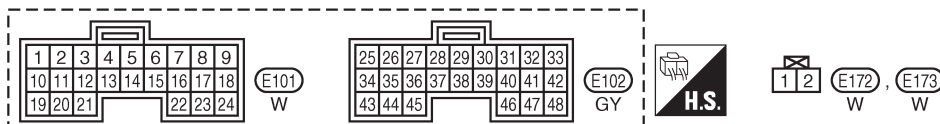
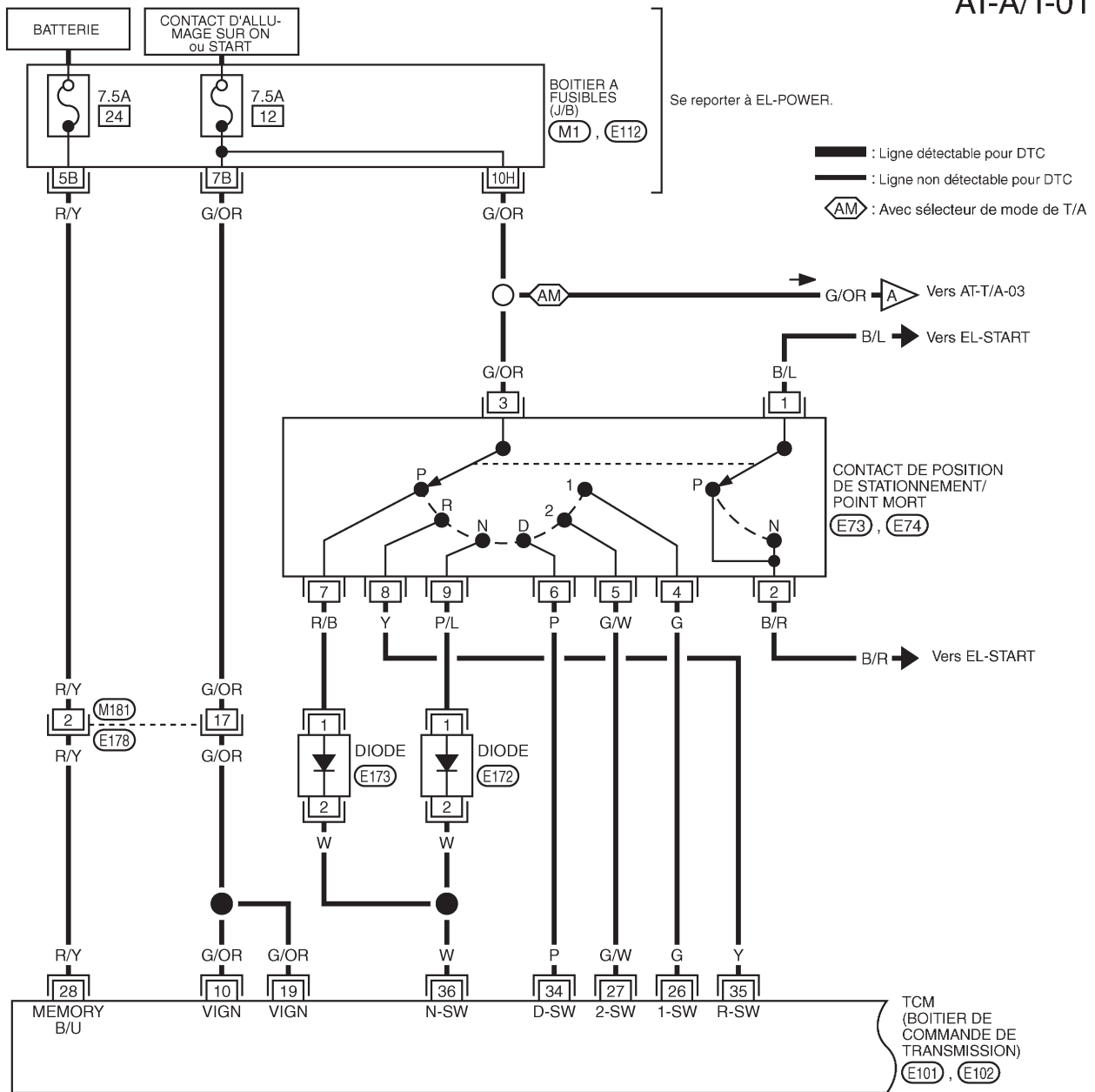

Consulter la dernière page dépliant.

M1
E112

Schéma de câblage — A/T — (Suite)

AT-A/T-02

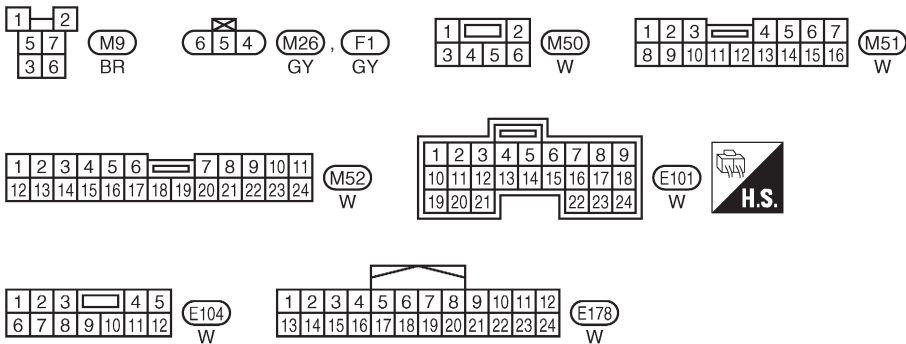
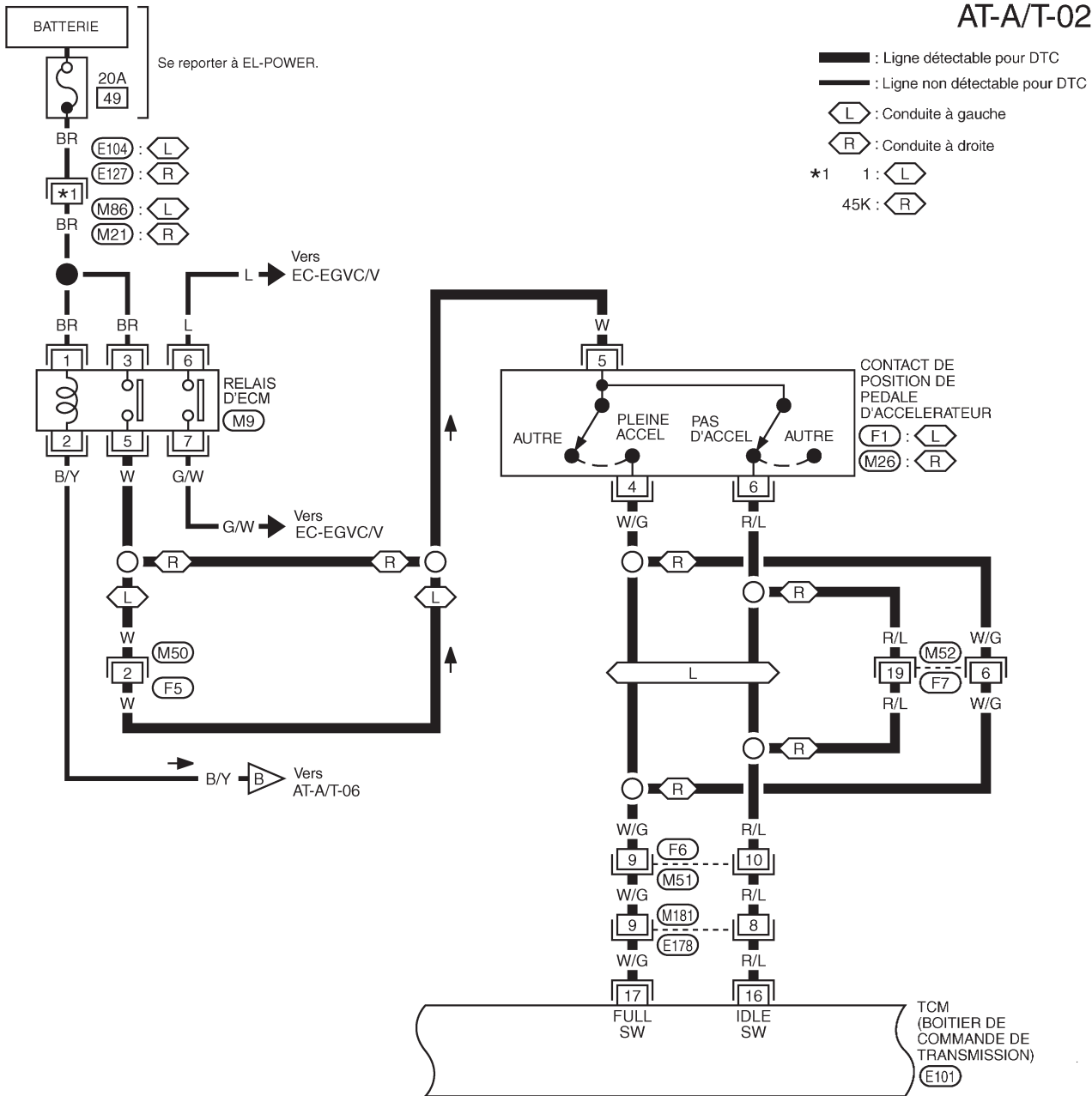

Consulter la dernière page dépliant.

(M21), (E127)

Schéma de câblage — A/T — (Suite)

AT-A/T-03

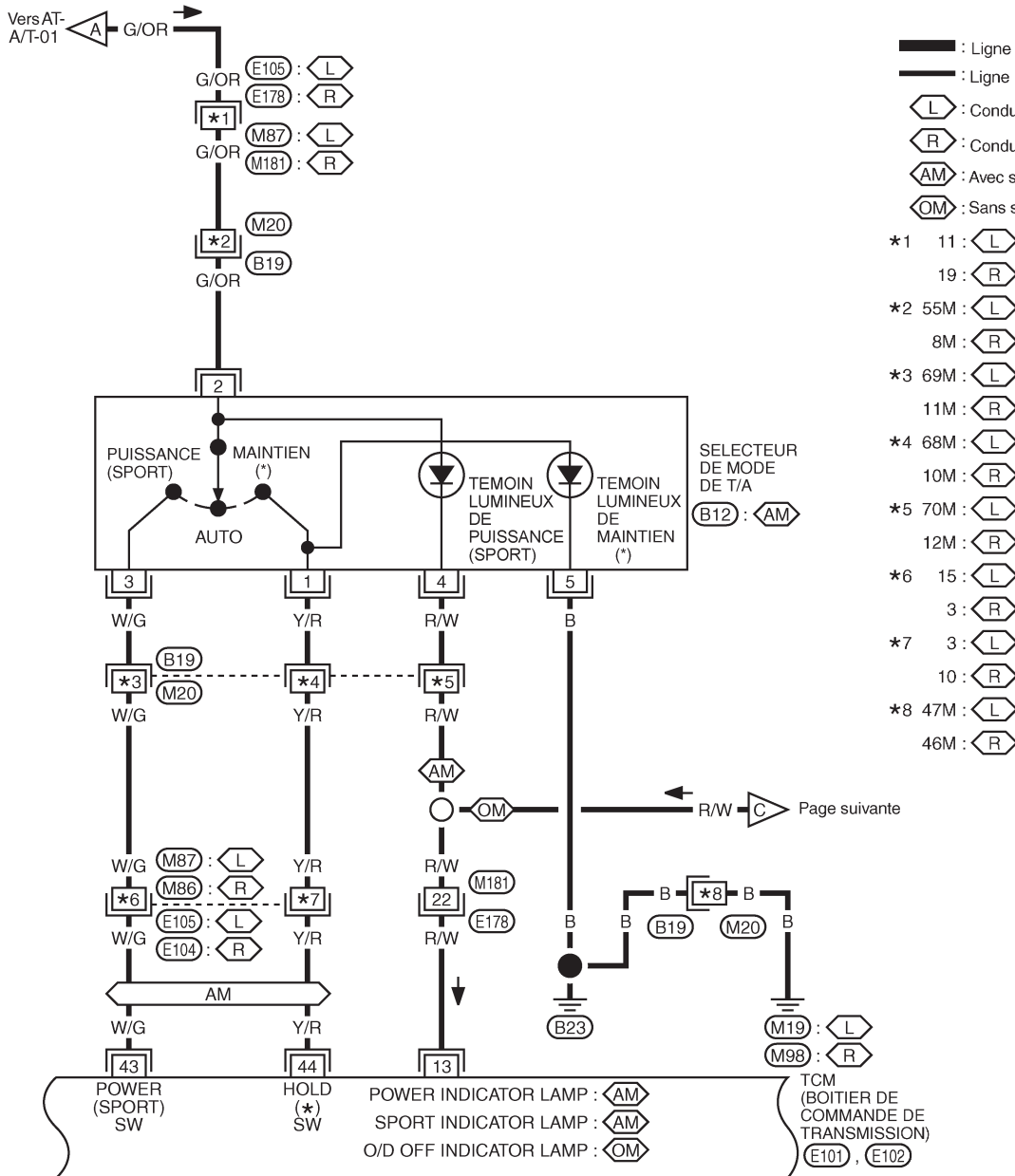

- : Ligne détectable pour DTC
 - : Ligne non détectable pour DTC
 - L : Conduite à gauche
 - R : Conduite à droite
 - AM : Avec sélecteur de mode de T/A
 - OM : Sans sélecteur de mode de T/A
- *1 11 : L
19 : R
 - *2 55M : L
8M : R
 - *3 69M : L
11M : R
 - *4 68M : L
10M : R
 - *5 70M : L
12M : R
 - *6 15 : L
3 : R
 - *7 3 : L
10 : R
 - *8 47M : L
46M : R

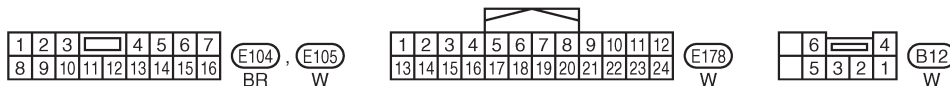
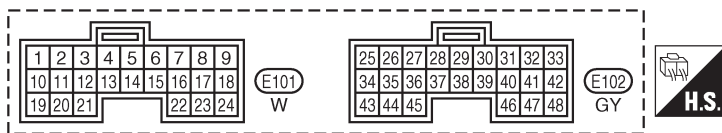

Consulter la dernière page dépliante.

M20, B19

Schéma de câblage — A/T — (Suite)

AT-A/T-04

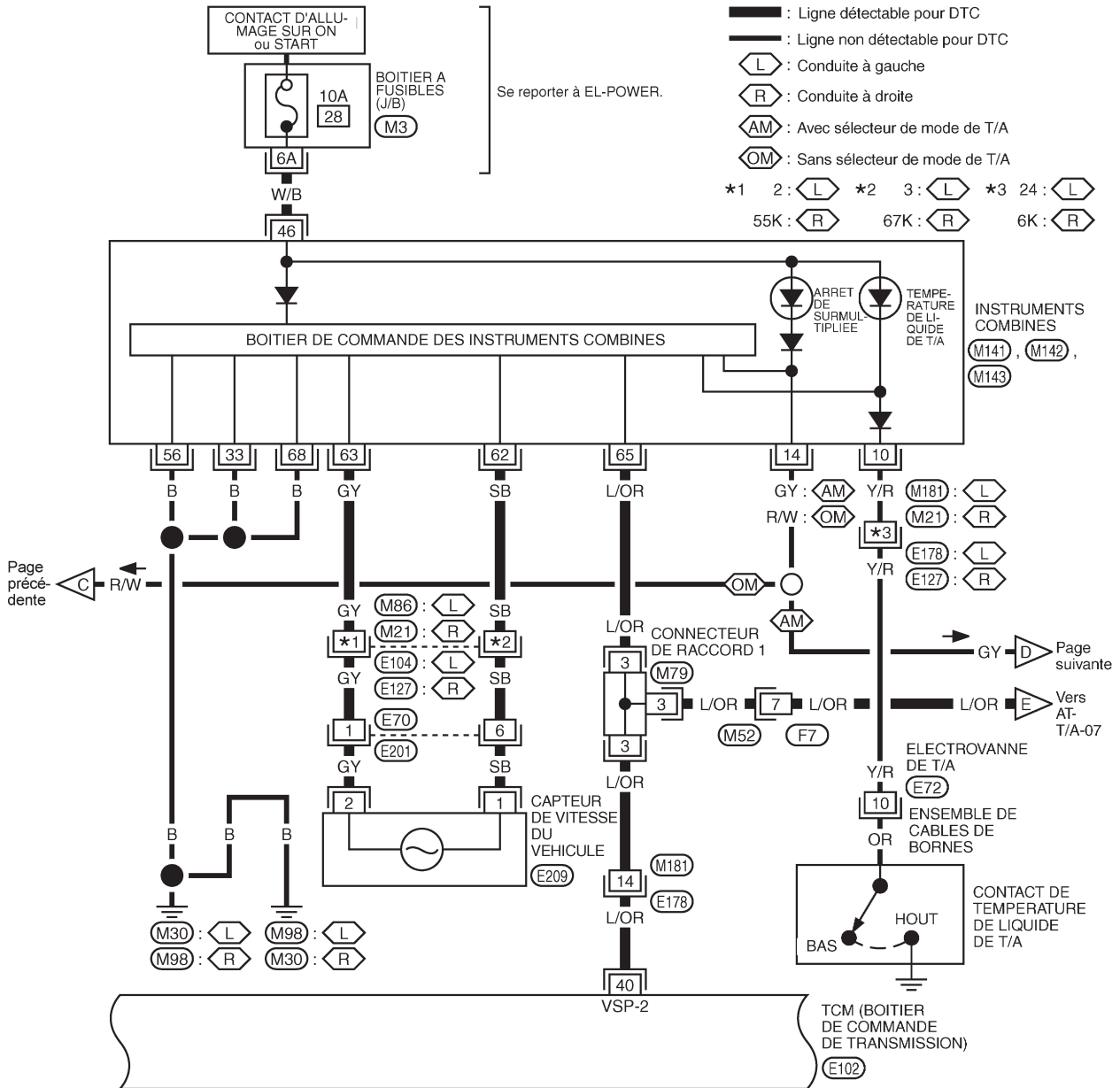

1	2	3	4	5	6	7	8	9	10	11		
12	13	14	15	16	17	18	19	20	21	22	23	24

M52 W

1	1	1	1	2	2	2	2	2	2
3	3	3	3	4	4	4	4	4	4

M79 W

Consulter la dernière page dépliant.

M21, E127
M3

1	2	3	4	5	6	7	8	9	10	11		
12	13	14	15	16	17	18	19	20	21	22	23	24

M141 W

25	26	27	28	29	30	31	32	33		
34	35	36	37	38	39	40	41	42	43	44

M142 BR

45	46	47	48	49	50	51	52	53	54	55		
56	57	58	59	60	61	62	63	64	65	66	67	68

M143 BR



Schéma de câblage — A/T — (Suite)

AT-A/T-05

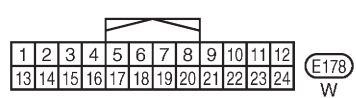
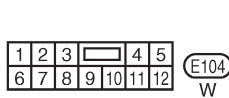
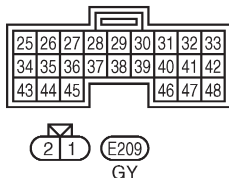
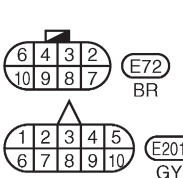
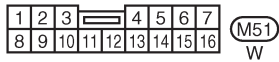
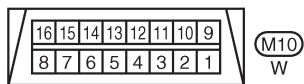
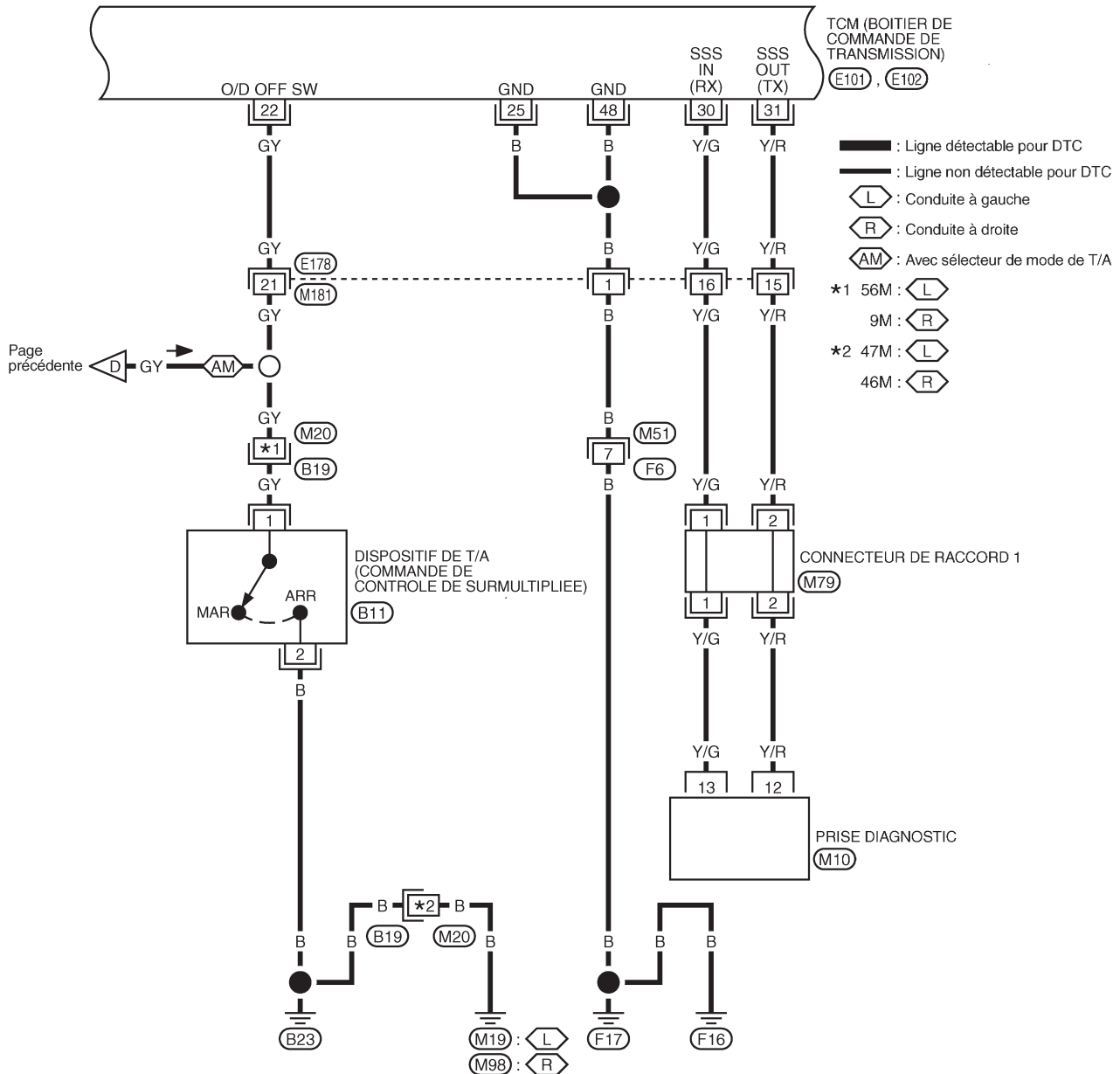

Consulter la dernière page dépliant.

(M20), (B19)



Schéma de câblage — A/T — (Suite)

AT-A/T-06

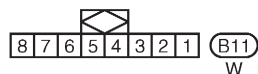
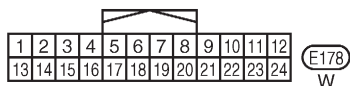
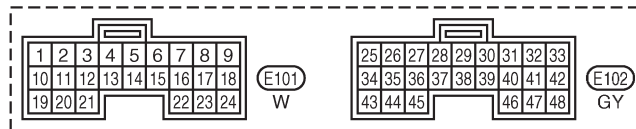
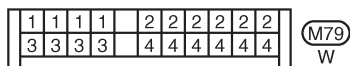
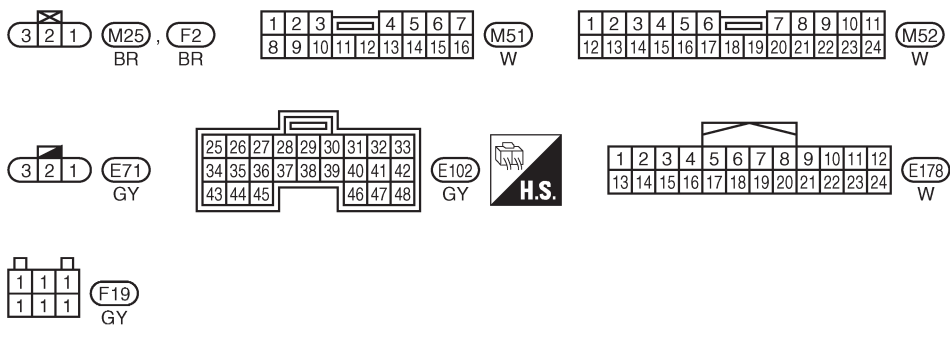
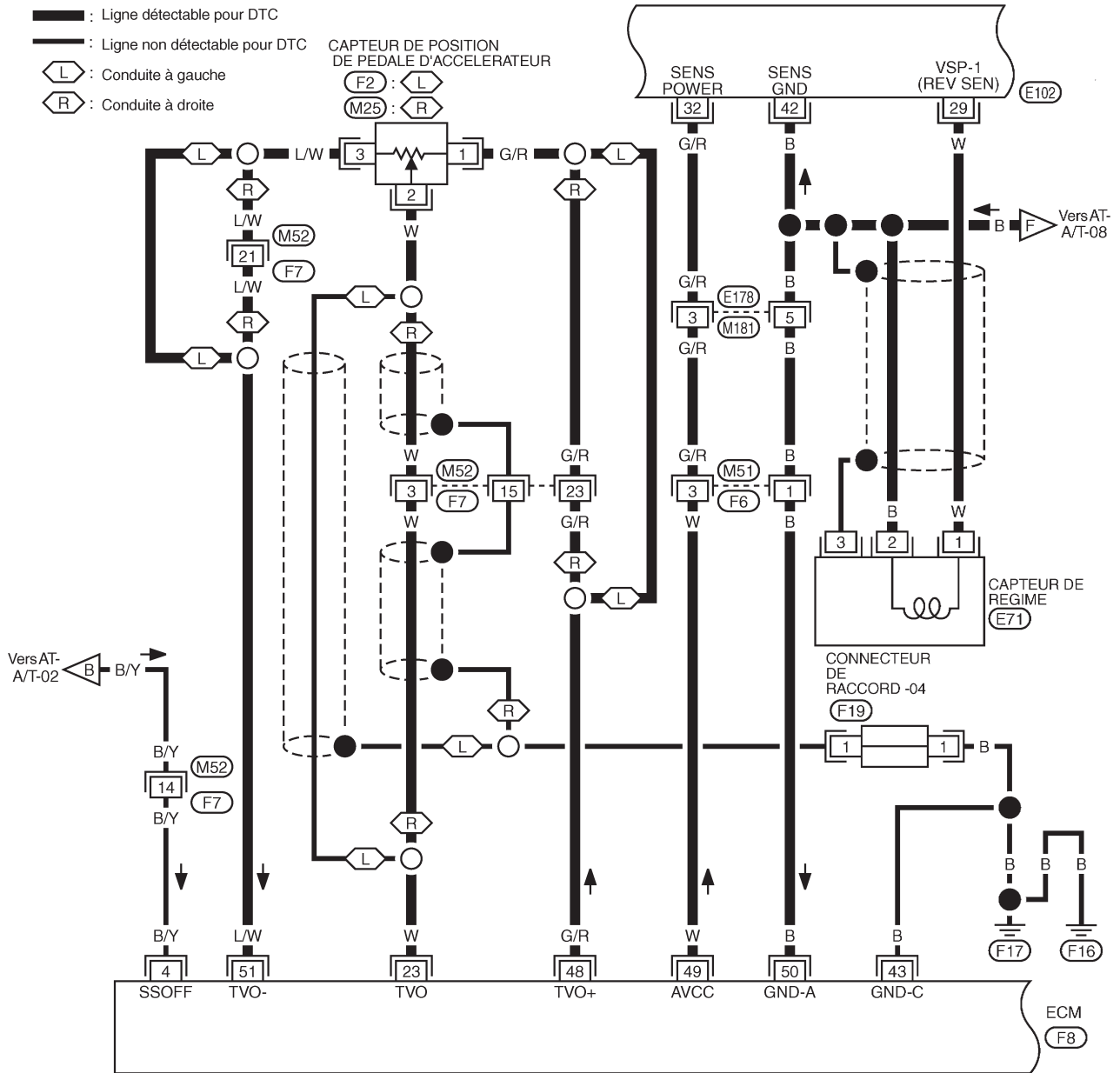

Consulter la dernière page dépliant.

(F8)

Schéma de câblage — A/T — (Suite)

AT-A/T-07

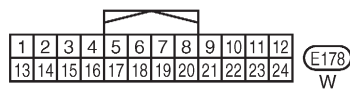
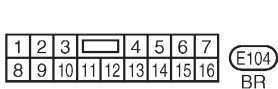
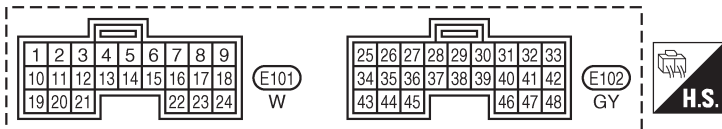
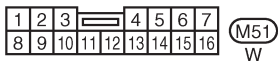
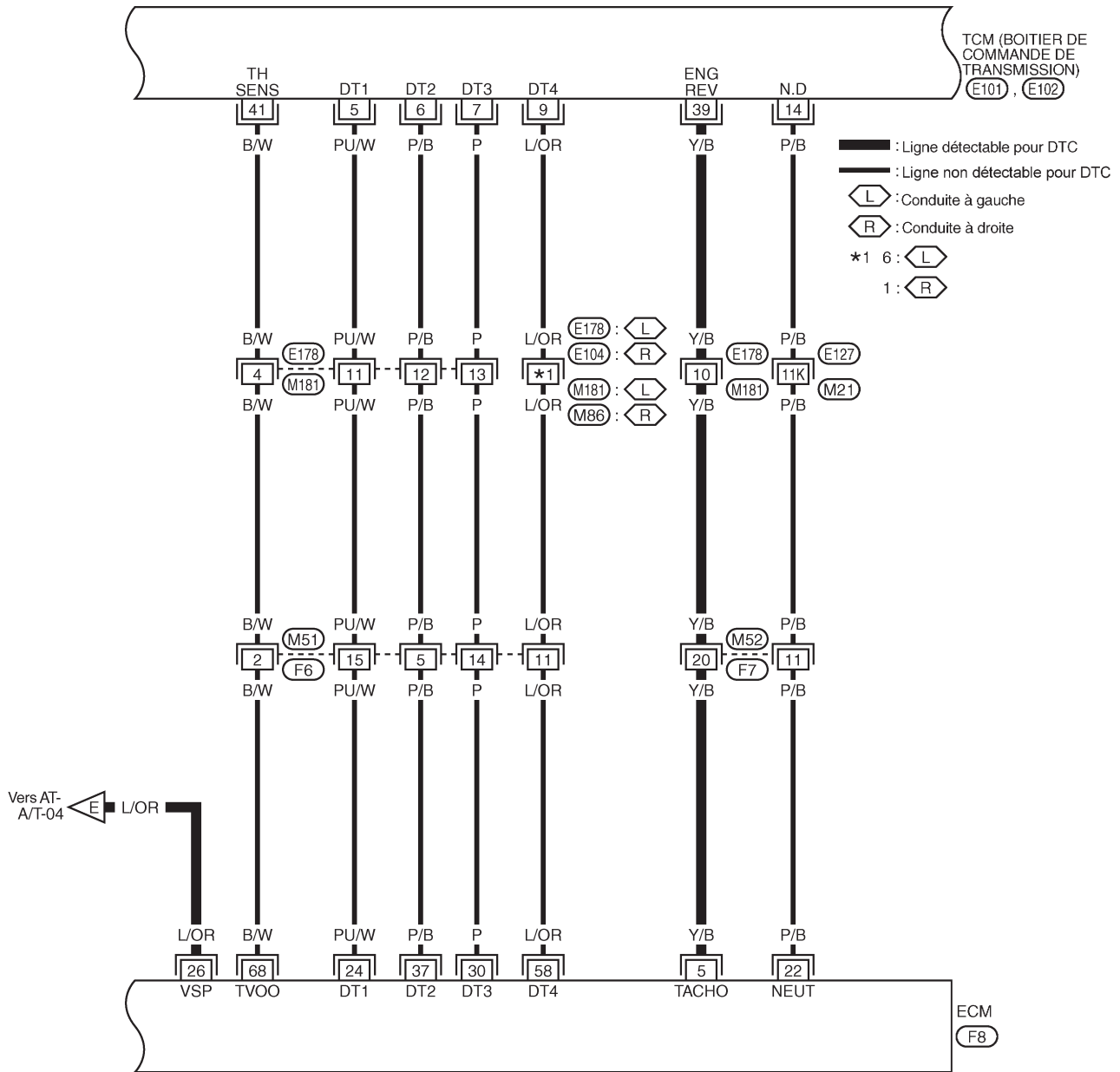

Consulter la dernière page dépliant.

(M21), (E127)

(F8)

Schéma de câblage — A/T — (Suite)

AT-A/T-08

— : Ligne détectable pour DTC
 — : Ligne non détectable pour DTC

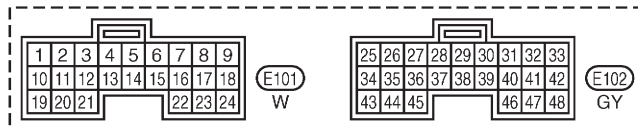
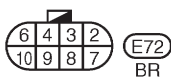
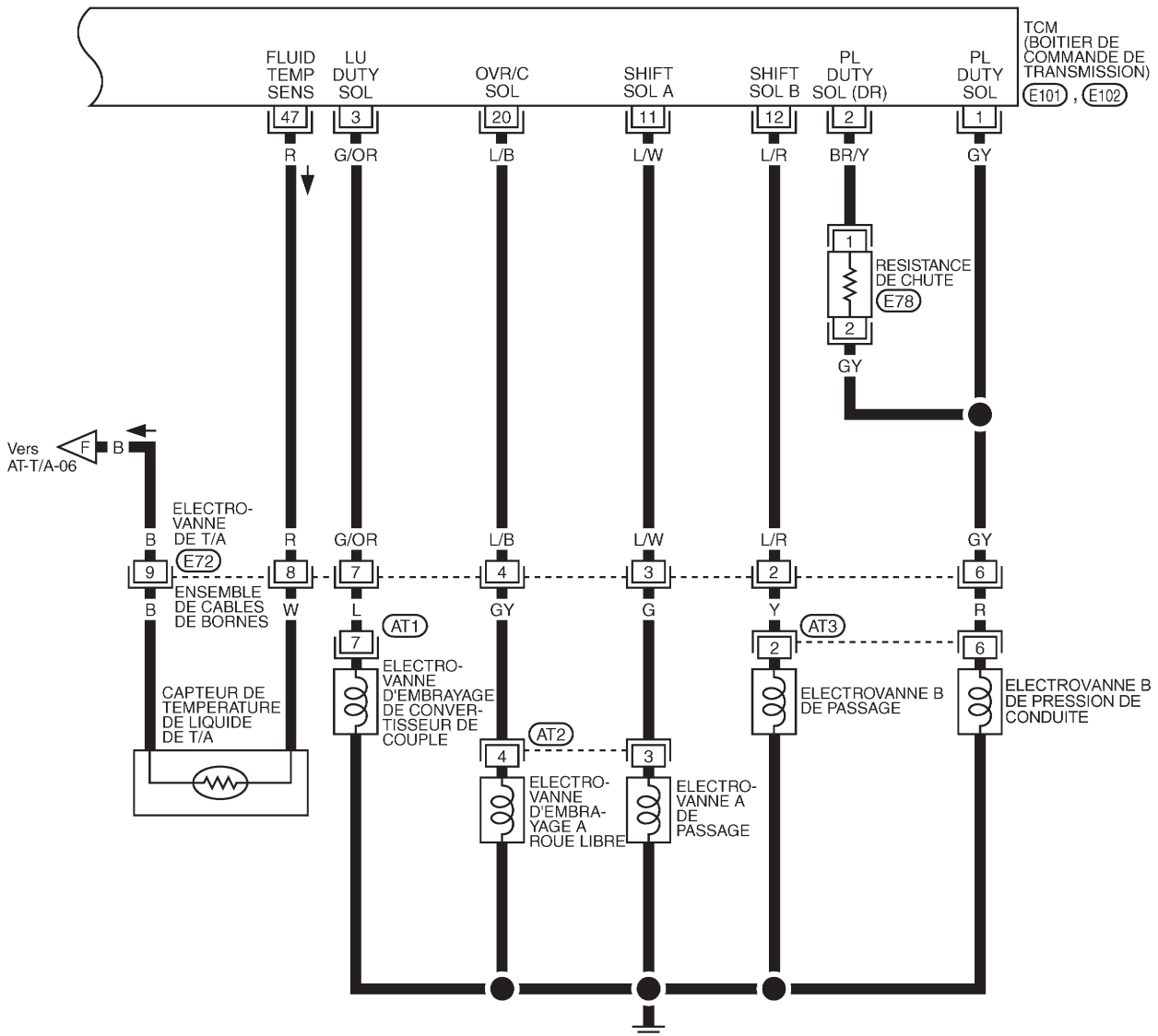

*: Ce connecteur n'est pas indiqué dans DISPOSITION DES FAISCEAUX, à la section EL.

Schéma de câblage — SHIFT —

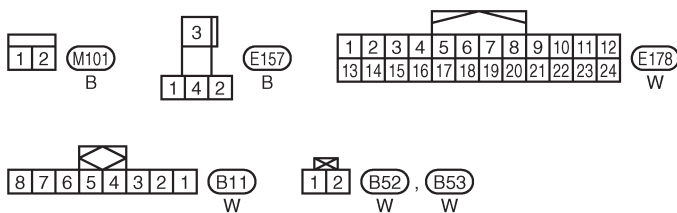
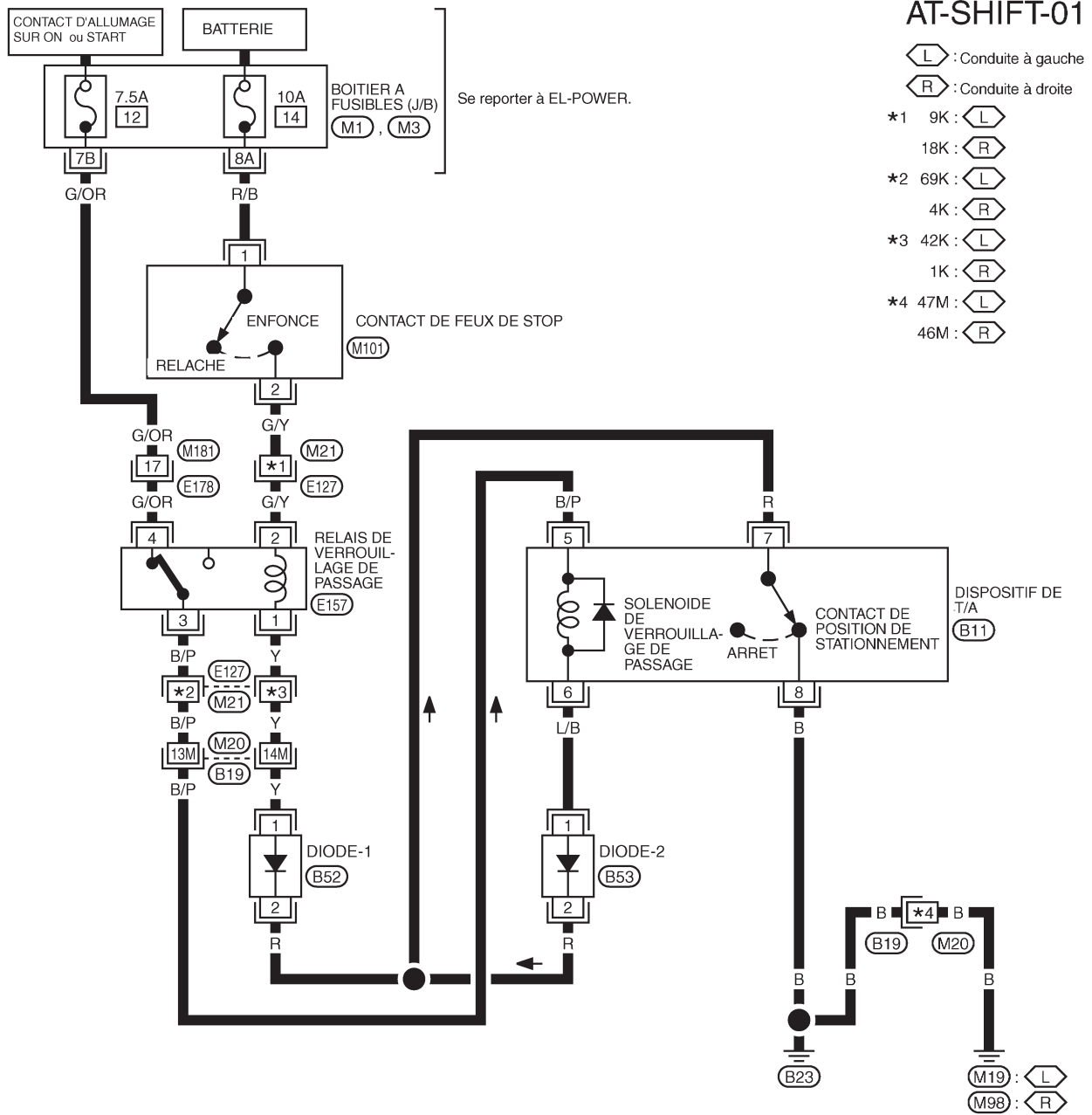

Consulter la dernière page dépliante.

- M20 , B19
- M21 , E127
- M1
- M3

Schéma de câblage — AT — STSIG

AT-STSIG-01

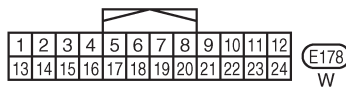
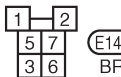
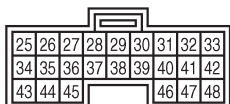
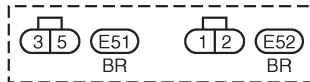
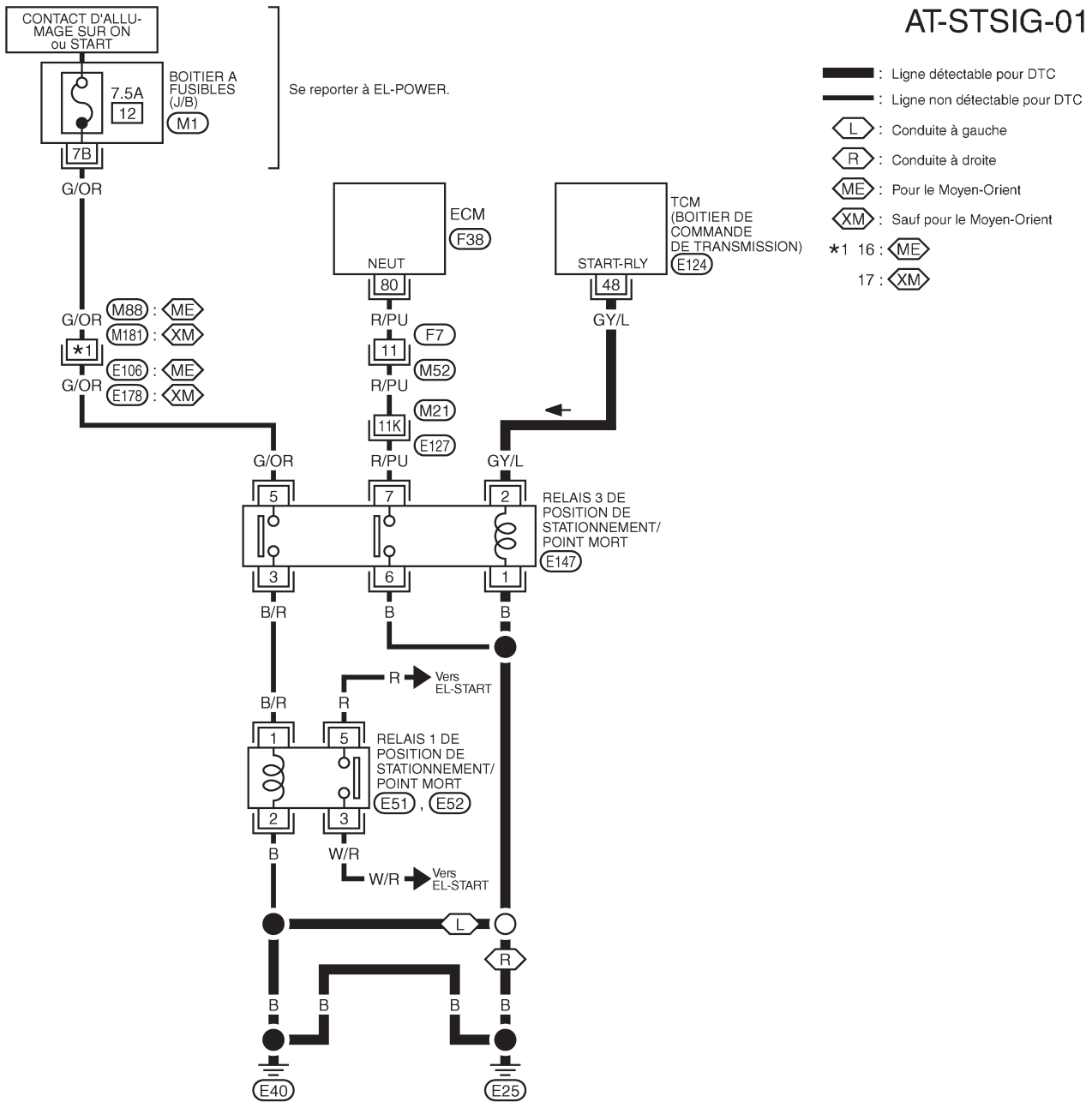

Consulter la dernière page dépliant.



Schéma de câblage — AT — POWER

AT-POWER-01

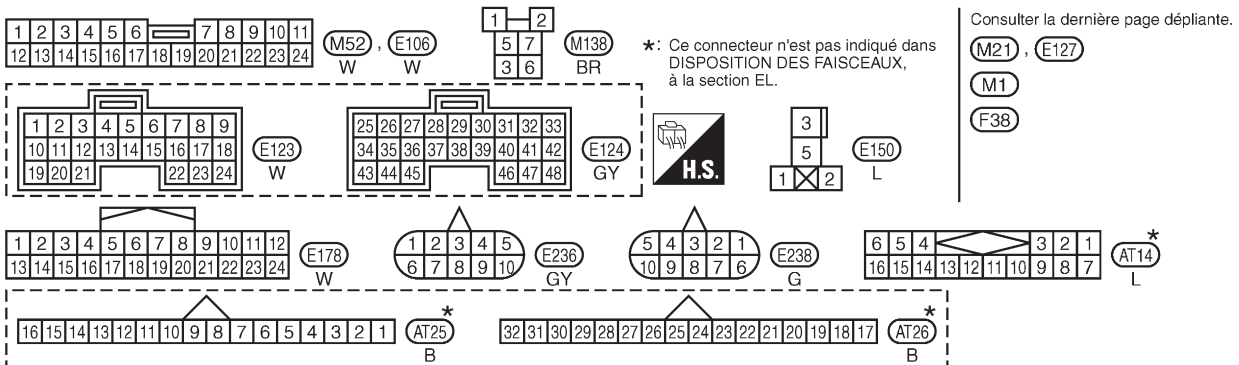
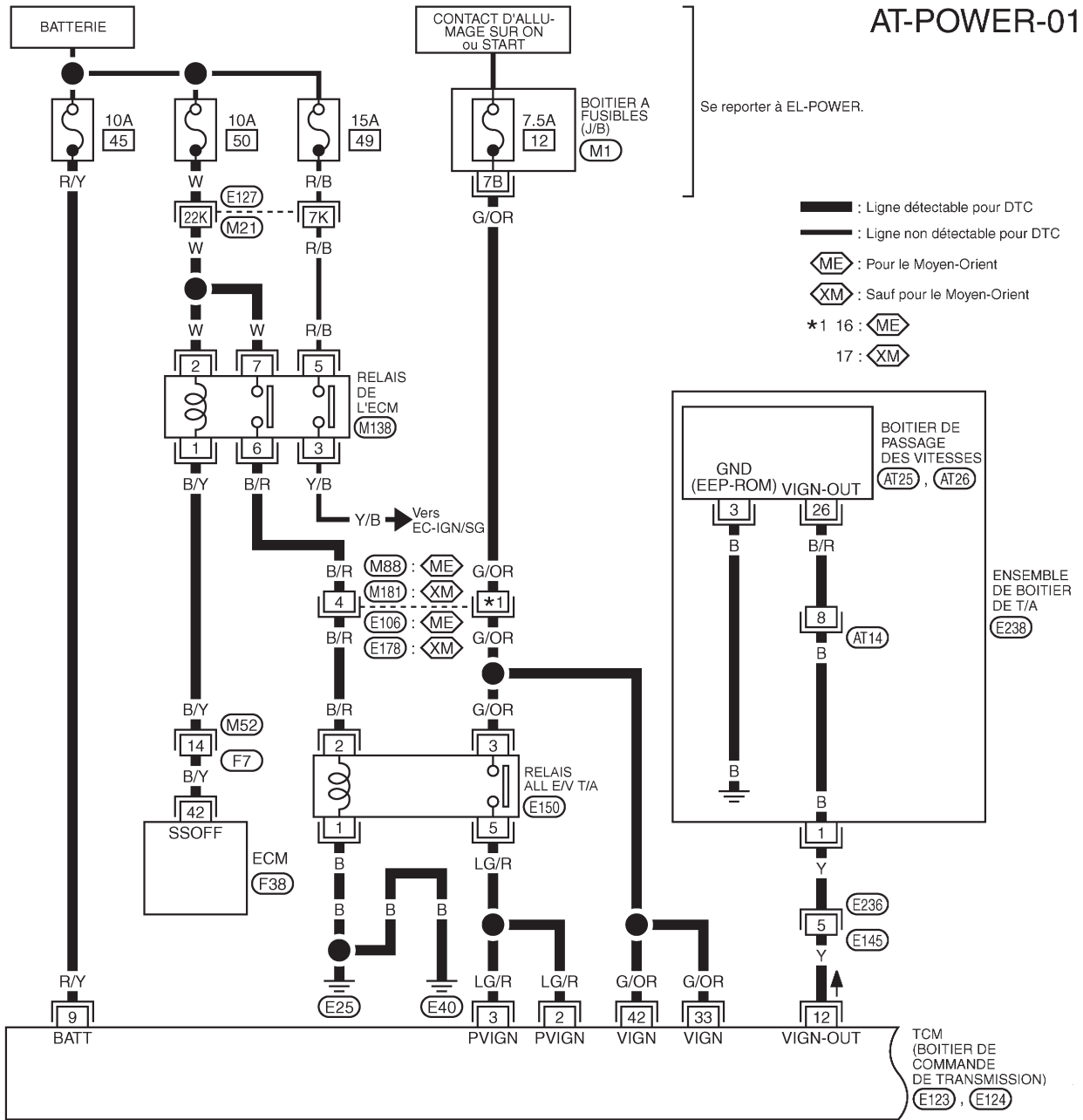

DTC P1701 BOITIER DE COMMANDE DE TRANSMISSION (ALIMENTATION ELECTRIQUE)

RE5R05A

Schéma de câblage — AT — POWER (Suite)

AT-POWER-02

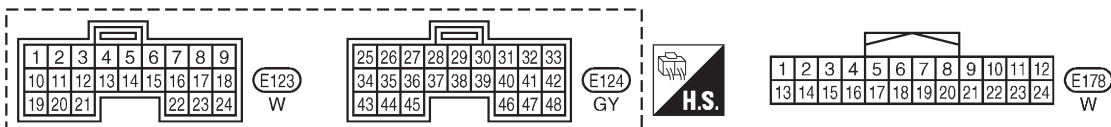
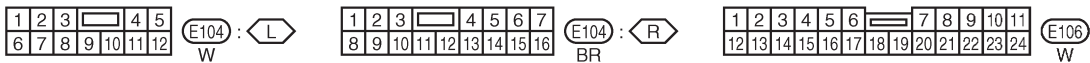
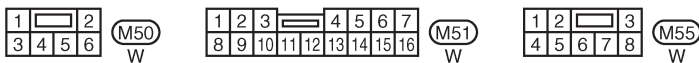
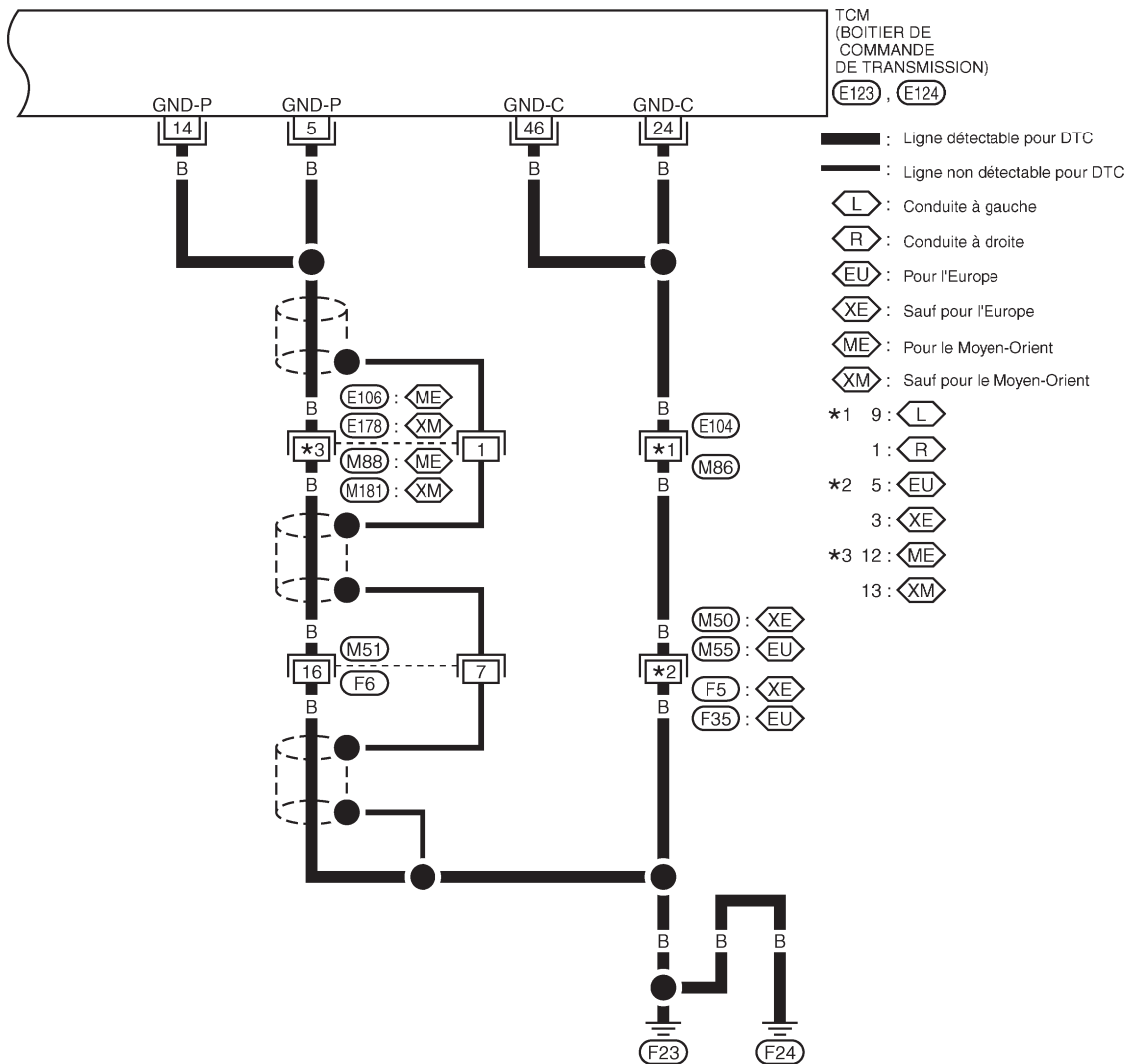

TAT155M

AT-5015

DTC P1815 COMMANDE DE MODE MANUEL

Schéma de câblage — AT — MMSW

AT-MMSW-01

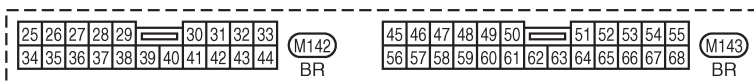
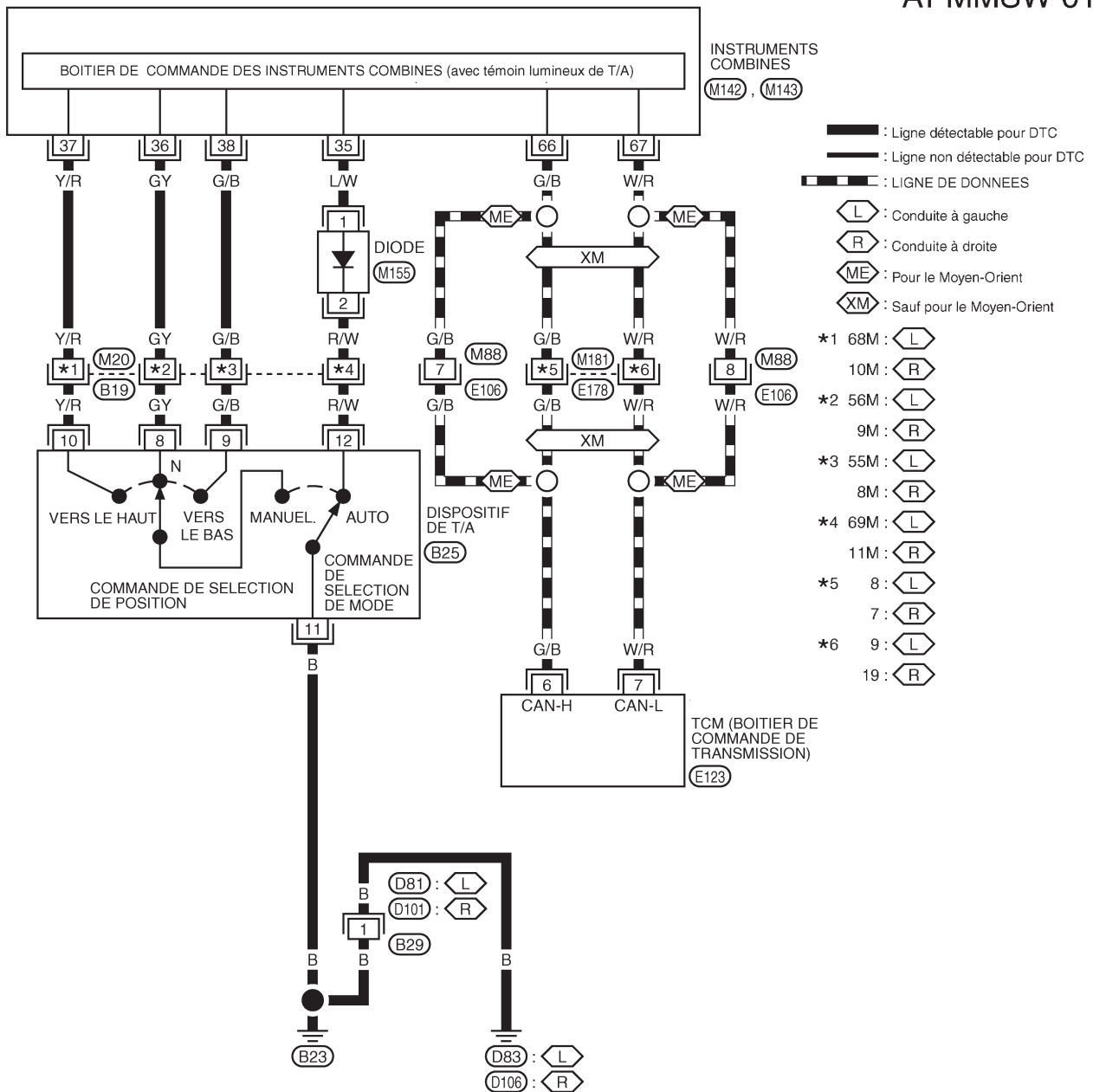

Consulter la dernière page dépliant.

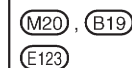

TAT156M

DIAGNOSTIC DES DEFAUTS POUR LES SYMPTOMES

Schéma de câblage — AT — NONDTC

AT-NONDTC-01

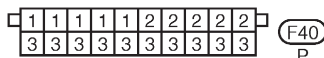
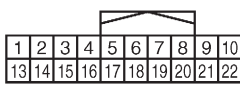
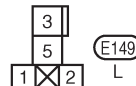
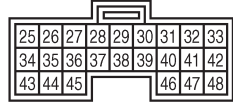
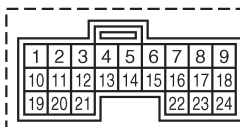
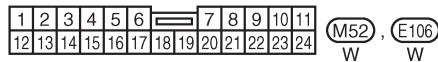
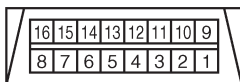
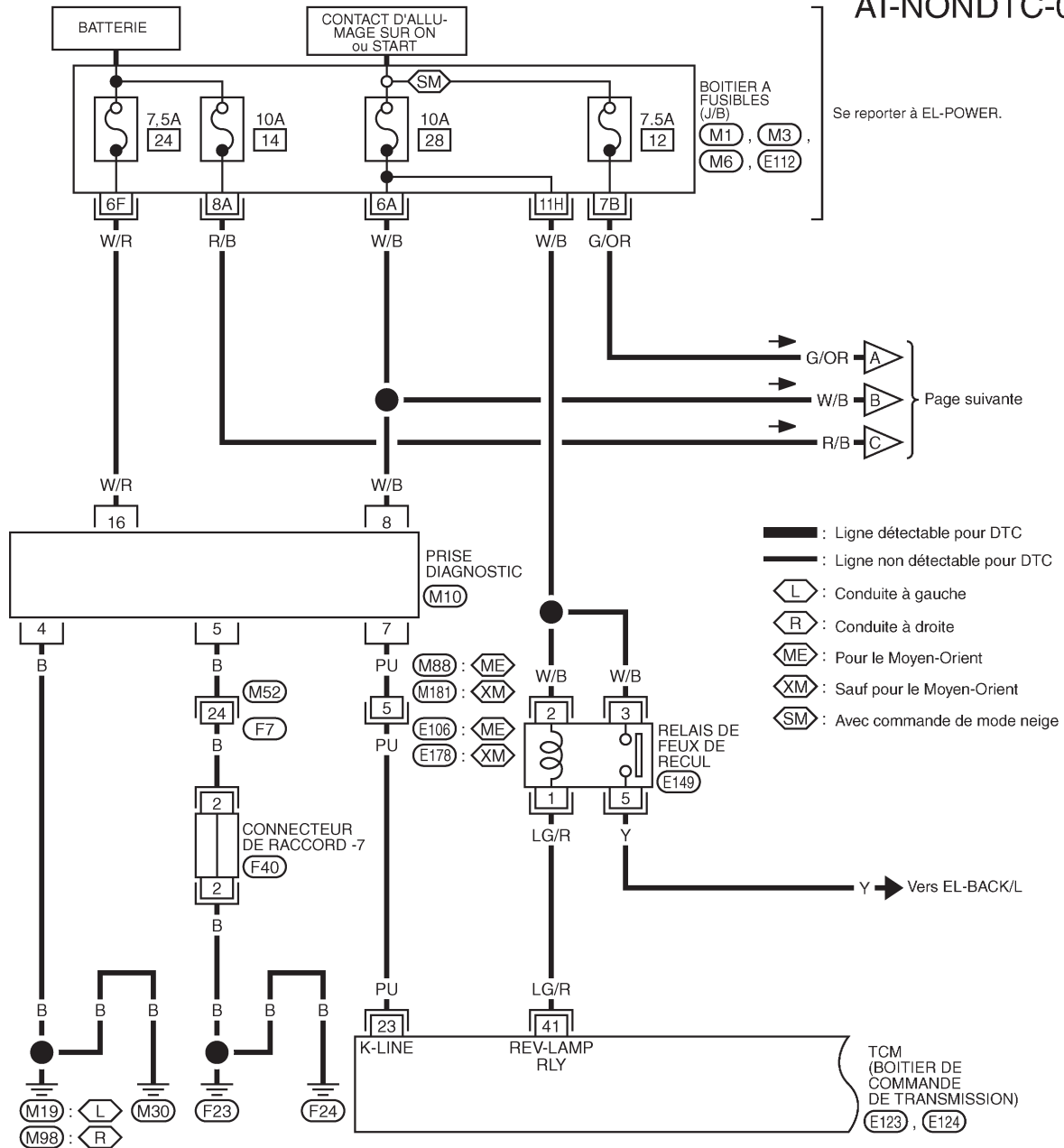

Consulter la dernière page dépliant.

- M1
- M3
- M6
- E112

DIAGNOSTIC DES DEFAUTS POUR LES SYMPTOMES

Schéma de câblage — AT — NONDTC (Suite)

AT-NONDTC-02

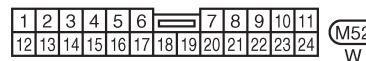
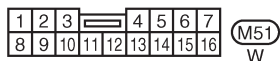
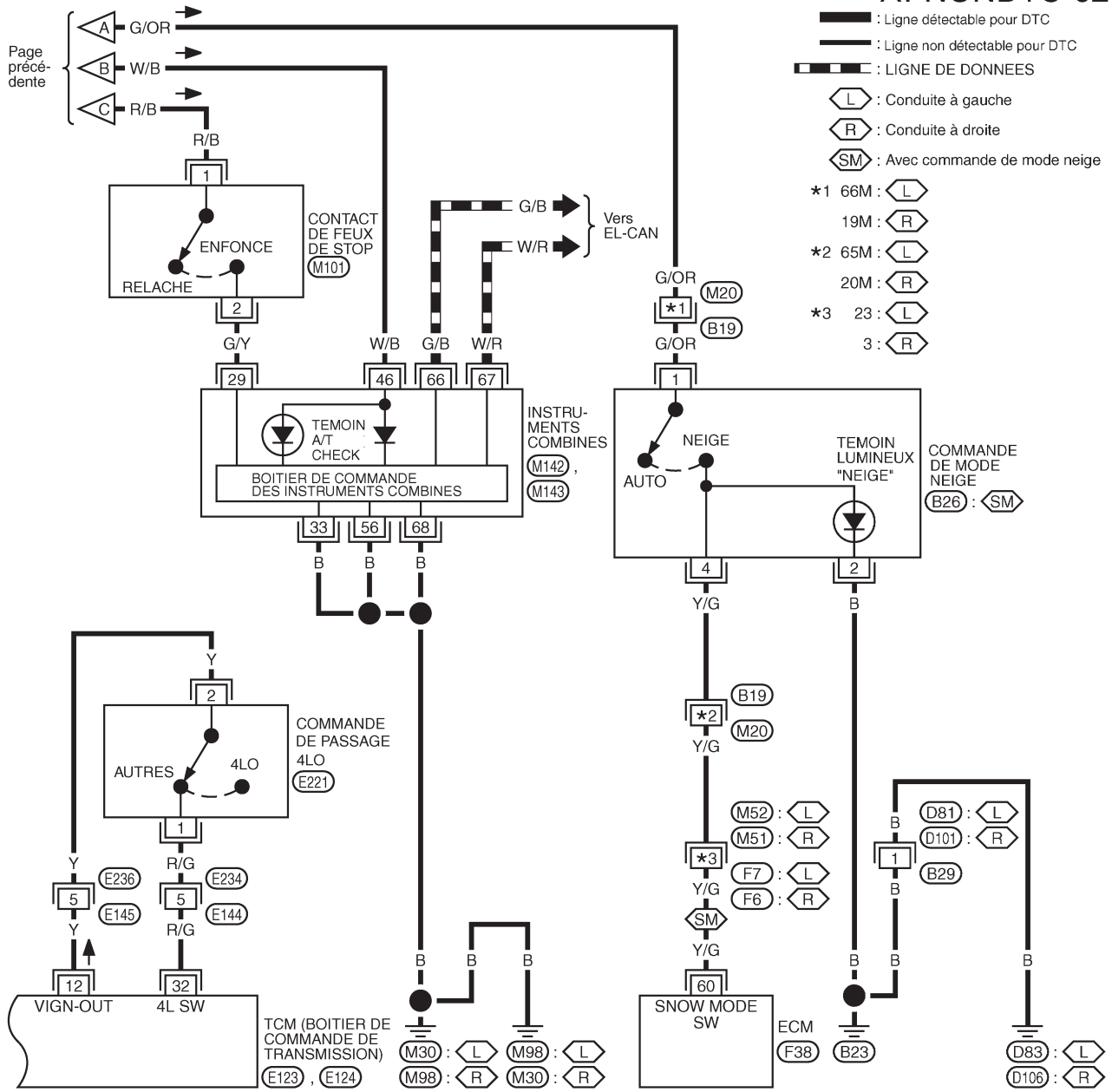

Consulter la dernière page dépliant.

(M20) (B19) (F38)

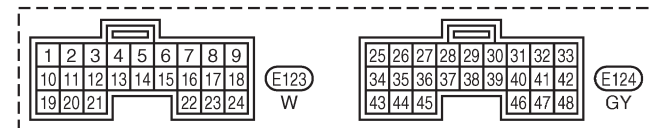
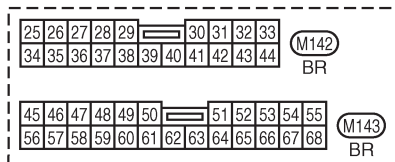

SYSTEME DE VERROUILLAGE DE T/A

Schéma de câblage — SHIFT —

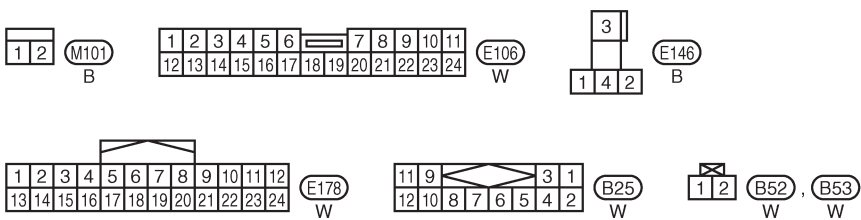
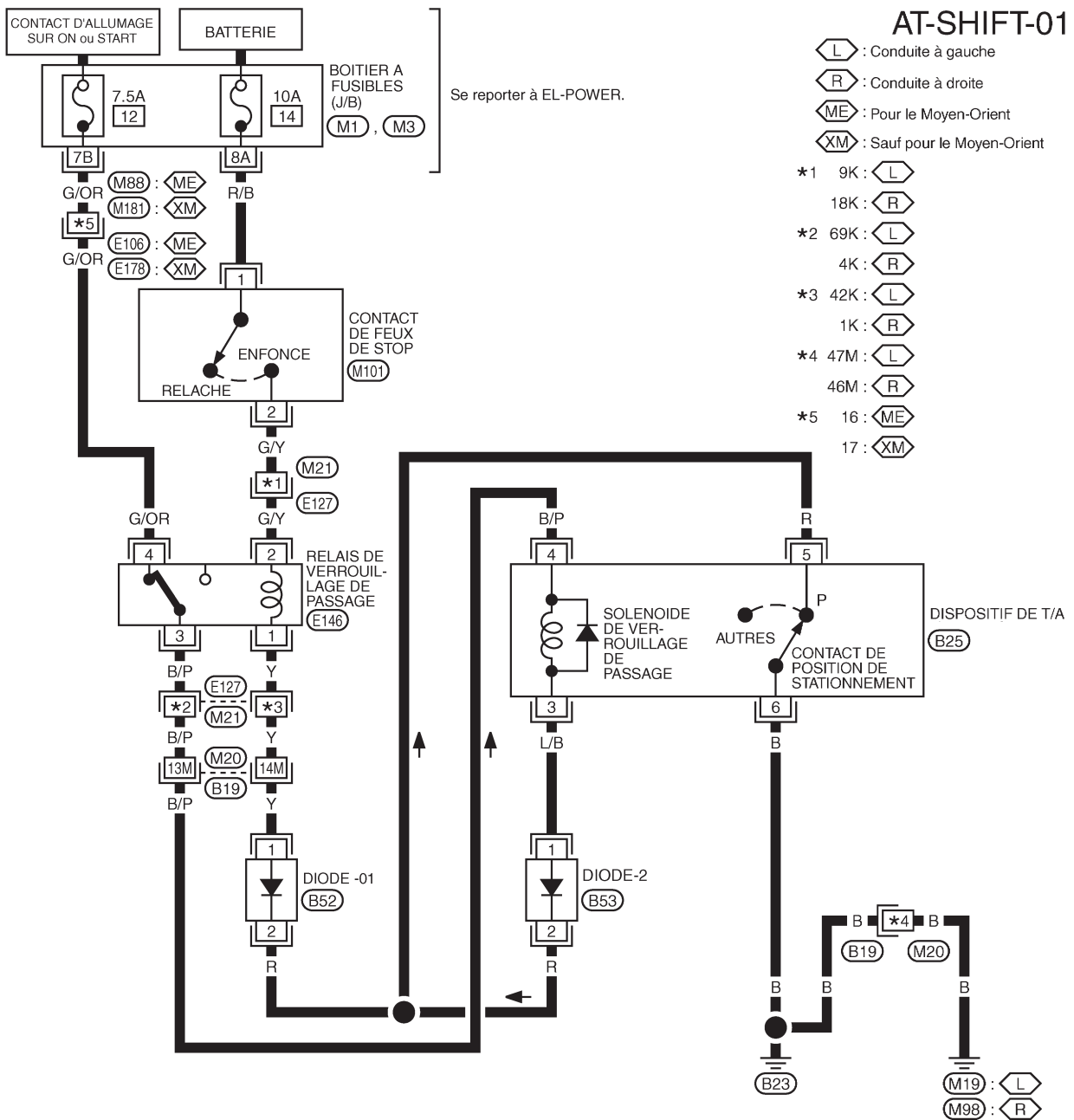

Consulter la dernière page dépliante.

- M20, B19
- M21, E127
- M1
- M3