

<SUPPLEMENT-II>

# ESSIEU ARRIERE ET SUSPENSION ARRIERE

## SECTION **RA**

### AVIS DE MODIFICATION :

- Les schémas de câblage ont été changés.

## TABLE DES MATIERES

<b>MECANISME DE DEVERROUILLAGE DU STABILISATEUR.....</b>	<b>2002</b>
Schéma de câblage.....	2002

# MECANISME DE DEVERROUILLAGE DU STABILISATEUR

## Schéma de câblage

### RA-STAB-01

L : Conduite à gauche  
R : Conduite à droite

\*1 2: L

55K: R

\*2 3: L

67K: R

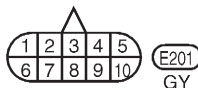
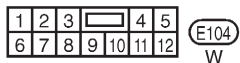
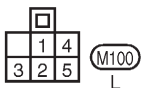
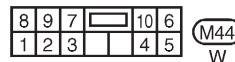
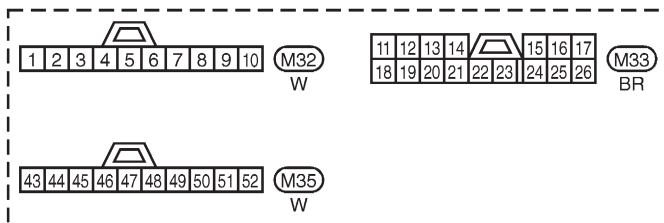
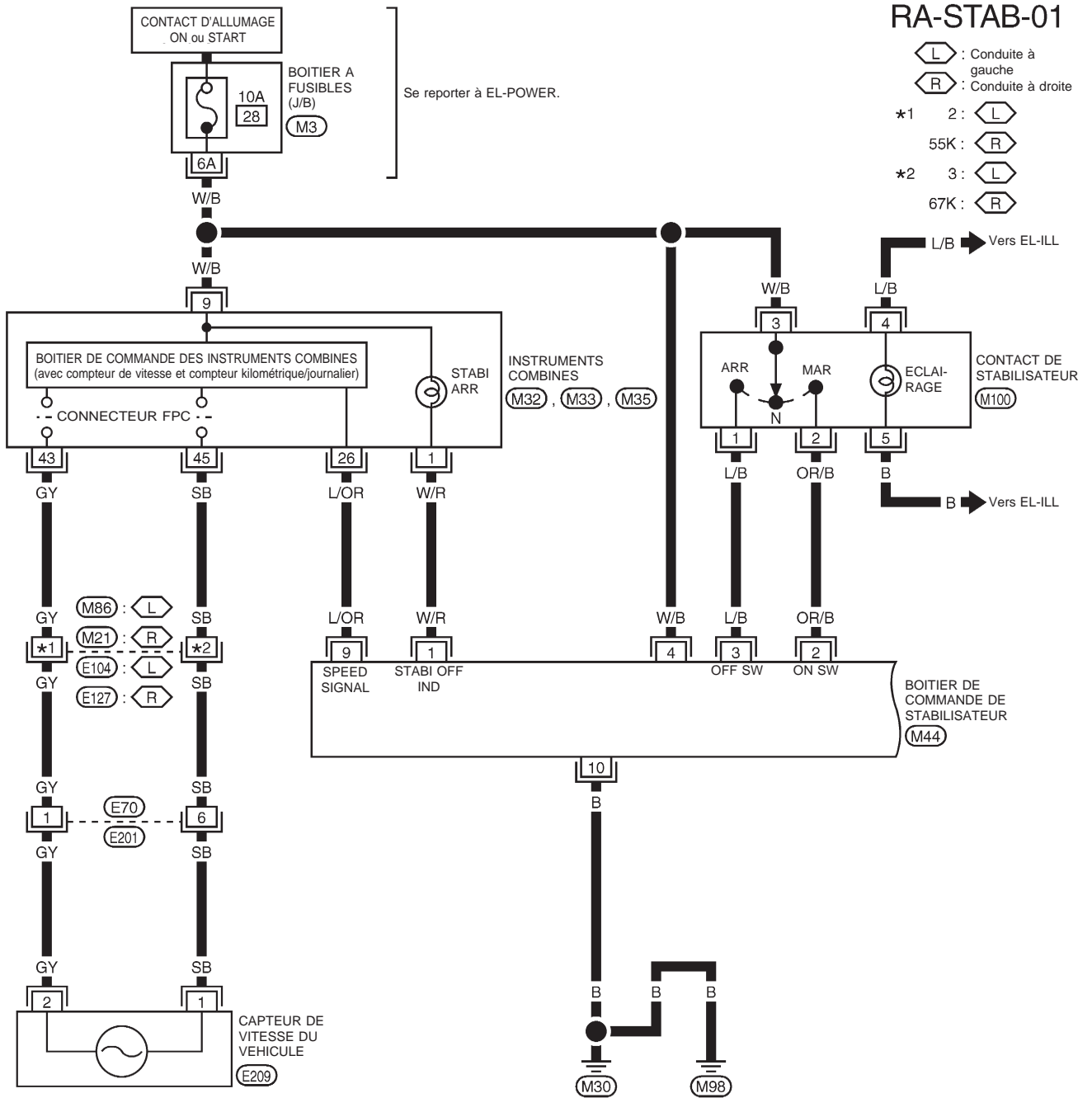

Consulter la dernière page dépliante.

M21 , E127

M3

TRA001

# MECANISME DE DEVERROUILLAGE DU STABILISATEUR

## Schéma de câblage (Suite)

RA-STAB-02

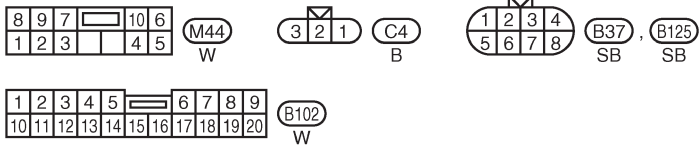
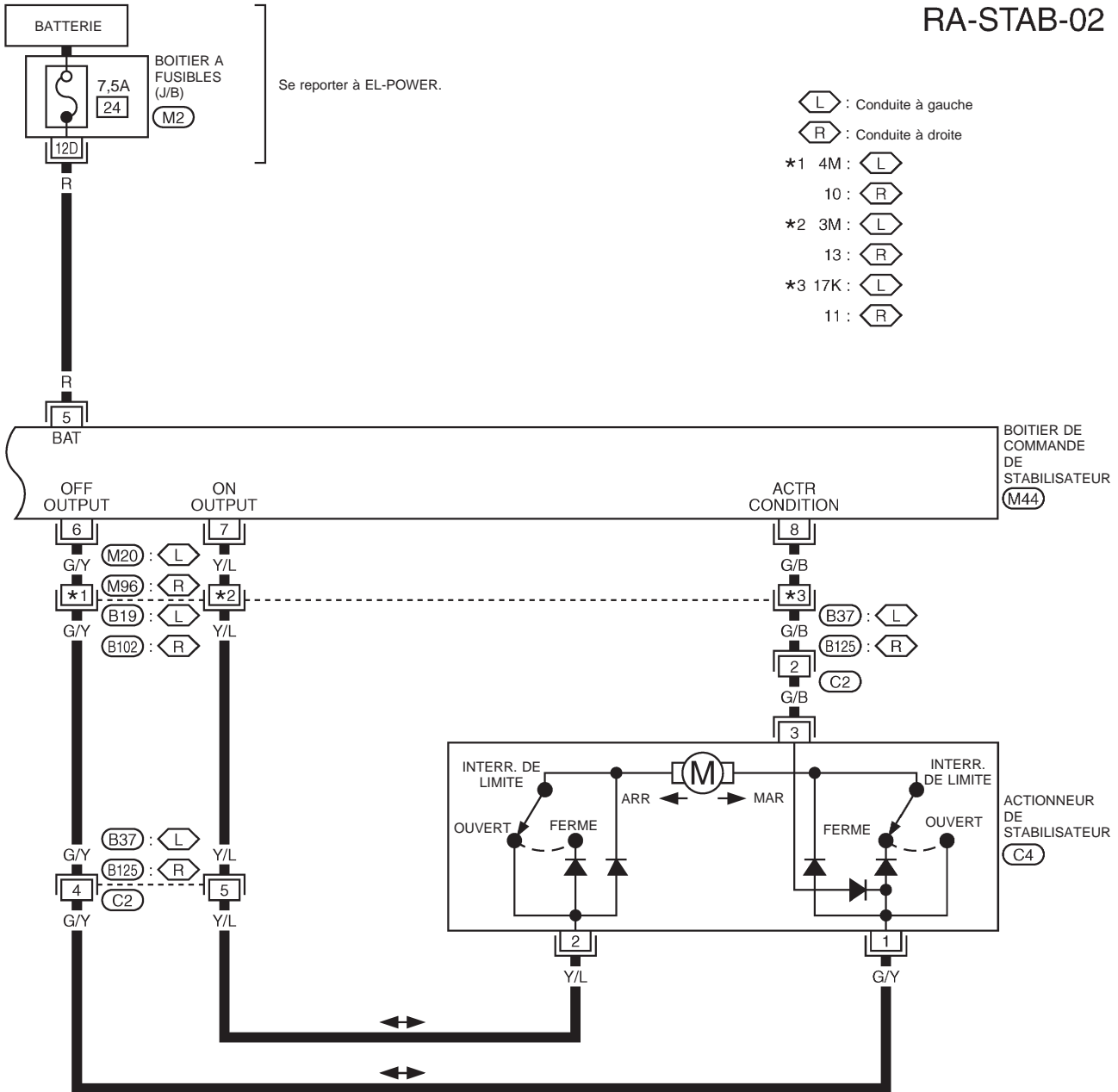

Consulter la dernière page dépliante.

(M20), (B19)  
(M2)

# MECANISME DE DEVERROUILLAGE DU STABILISATEUR

---

RA-2004