

**AVIS DE MODIFICATION :**

- Les schémas de câblage ont été modifiés.

**TABLE DES MATIERES**

<b>DIAGNOSTICS DES DEFAUTS</b> .....	2002	Schéma de câblage — ABS — .....	2003
Schéma .....	2002		

## Schéma

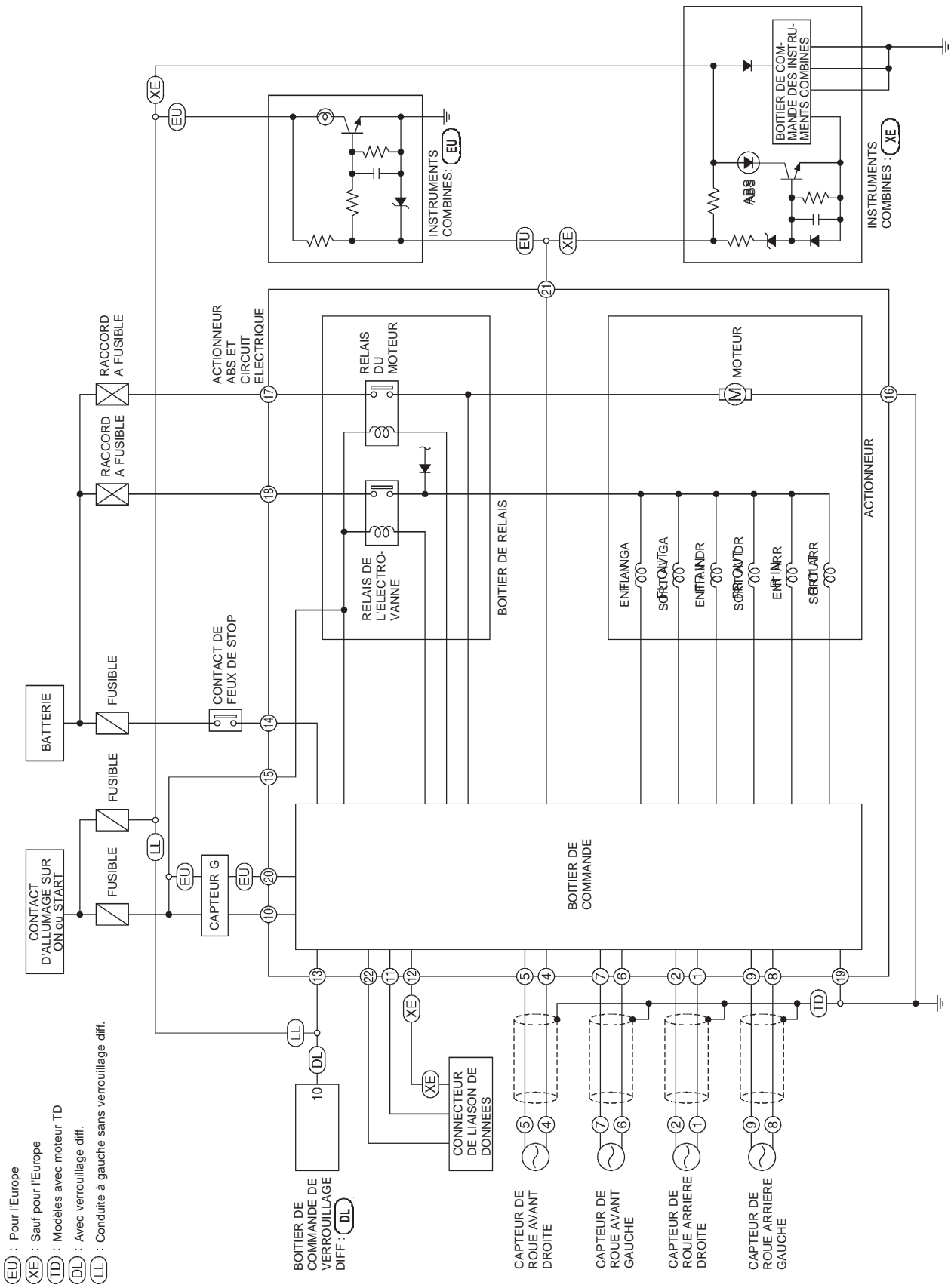

- (EU) : Pour l'Europe
- (XE) : Sauf pour l'Europe
- (TD) : Modèles avec moteur TD
- (DL) : Avec verrouillage diff.
- (LL) : Conduite à gauche sans verrouillage diff.

# DIAGNOSTICS DES DEFAUTS

## Schéma de câblage — ABS —

BR-ABS-01

Se reporter à EL-POWER.

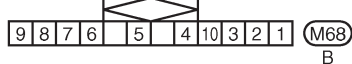
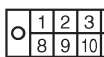
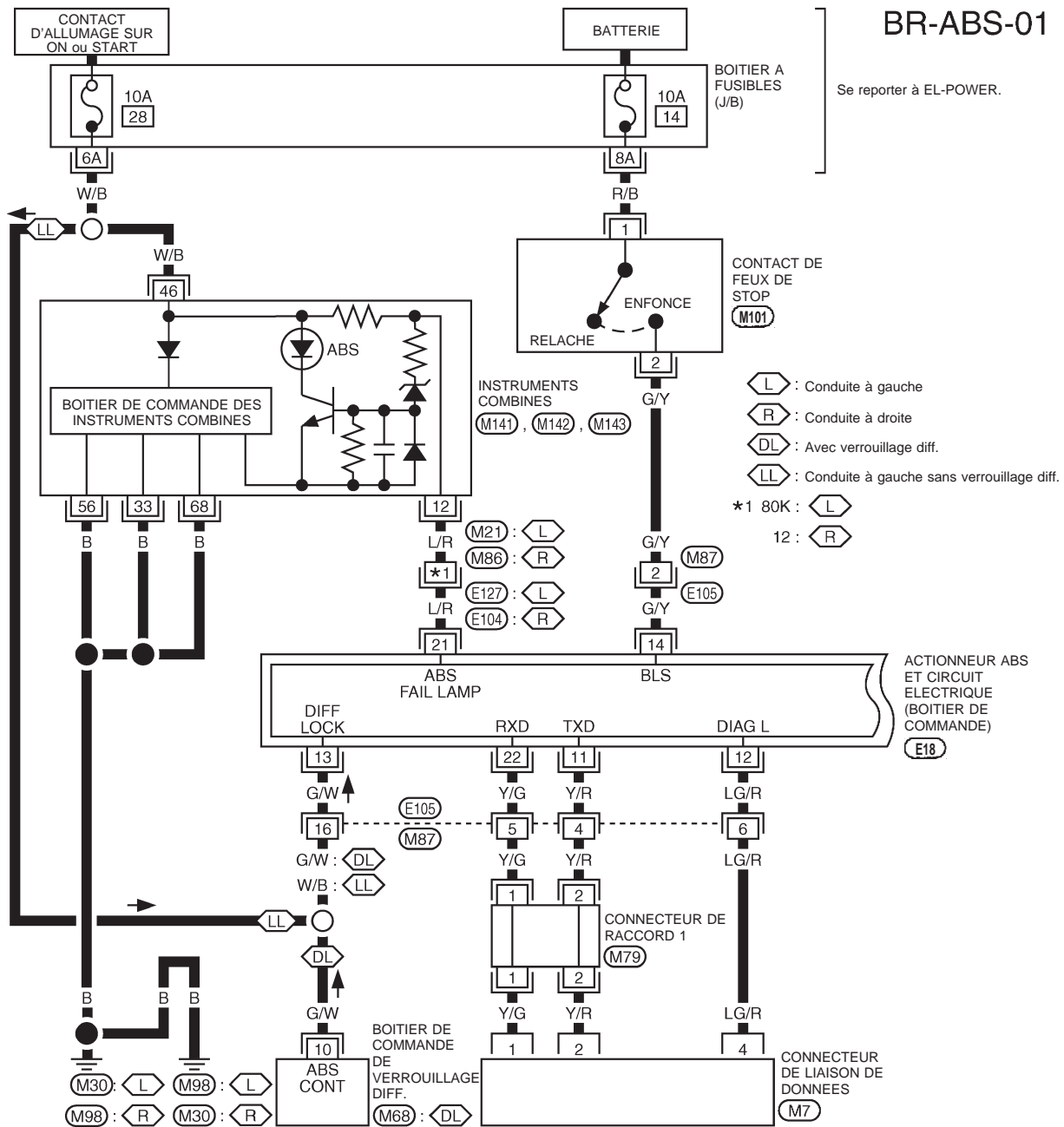

Consulter la dernière page dépliant.

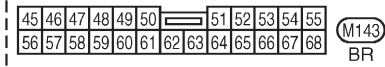
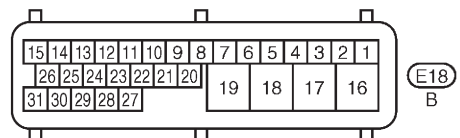
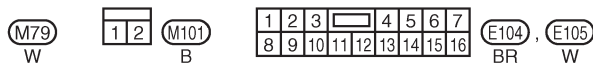
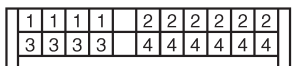
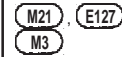

# DIAGNOSTICS DES DEFAUTS

## Schéma de câblage — ABS — (Suite)

BR-ABS-02

Se reporter à EL-POWER.

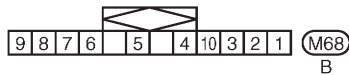
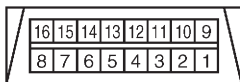
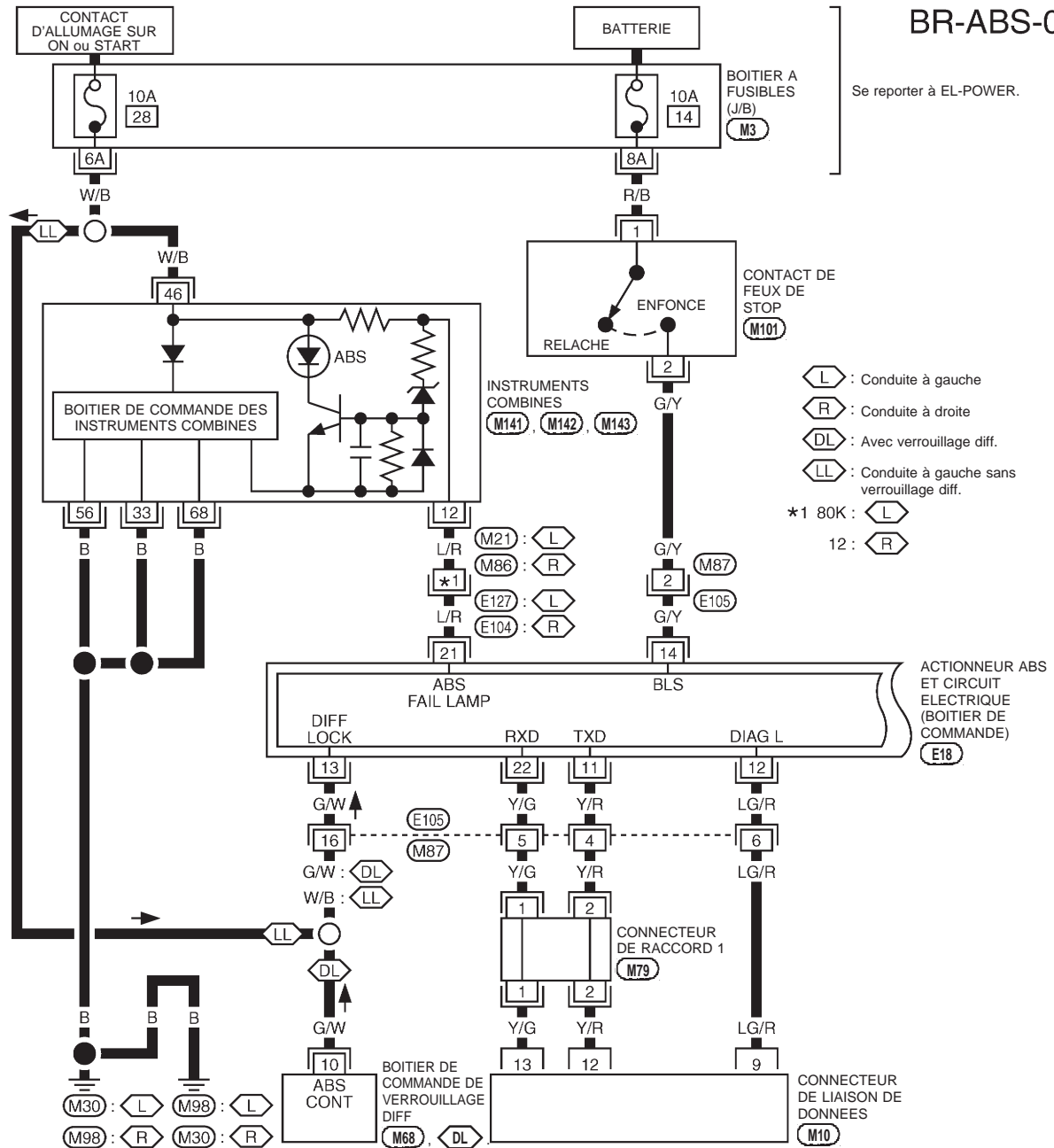

Consulter la dernière page dépliante.

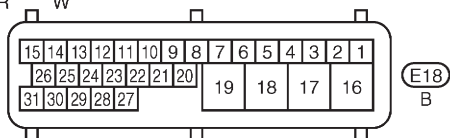
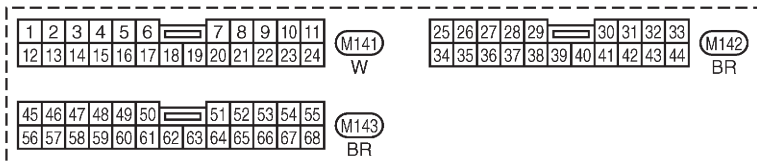
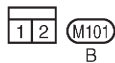
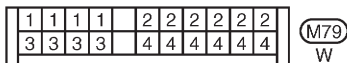
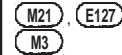

# DIAGNOSTICS DES DEFAUTS

## Schéma de câblage — ABS — (Suite)

BR-ABS-03

Se reporter à EL-POWER.

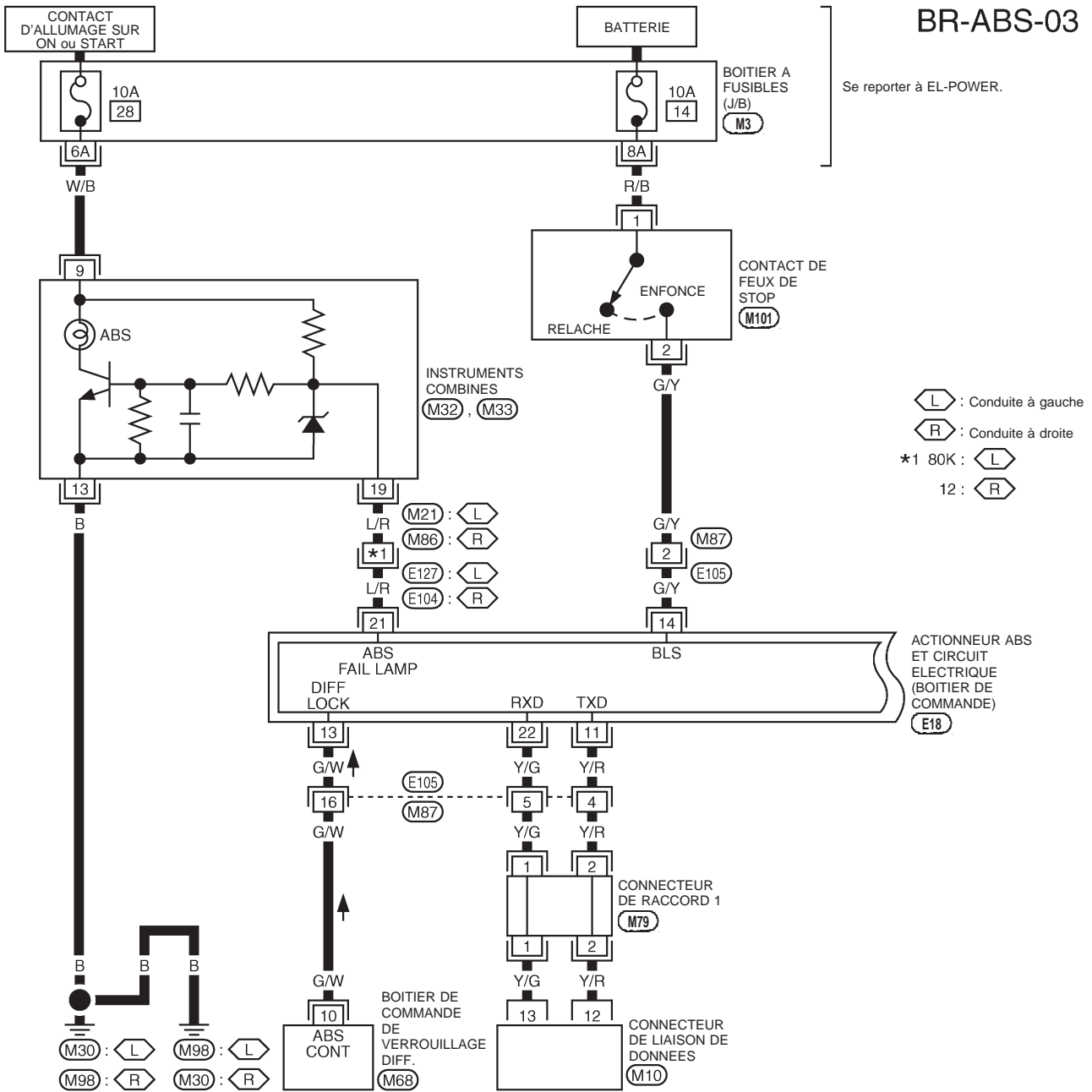

- L : Conduite à gauche
- R : Conduite à droite
- \*1 80K : L
- 12 : R

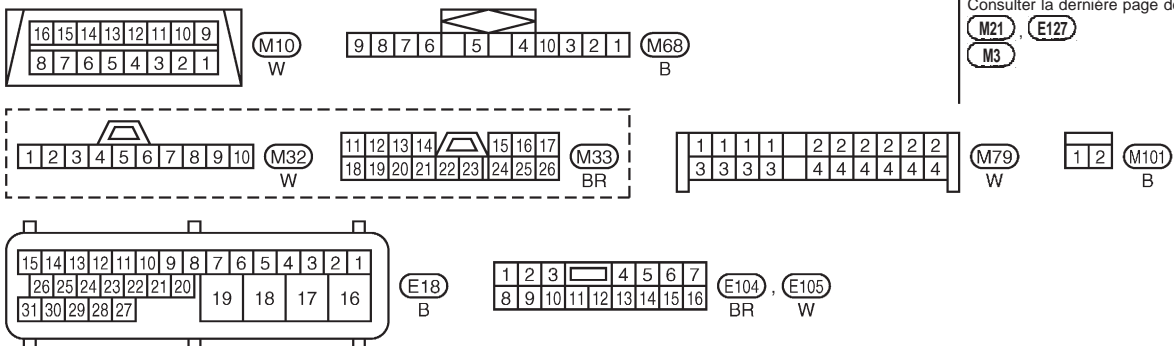

Consulter la dernière page dépliante.

- M21 , E127
- M3

# DIAGNOSTICS DES DEFAUTS

## Schéma de câblage — ABS — (Suite)

BR-ABS-04

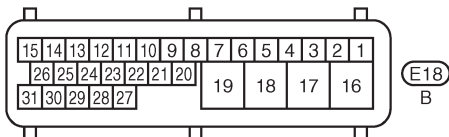
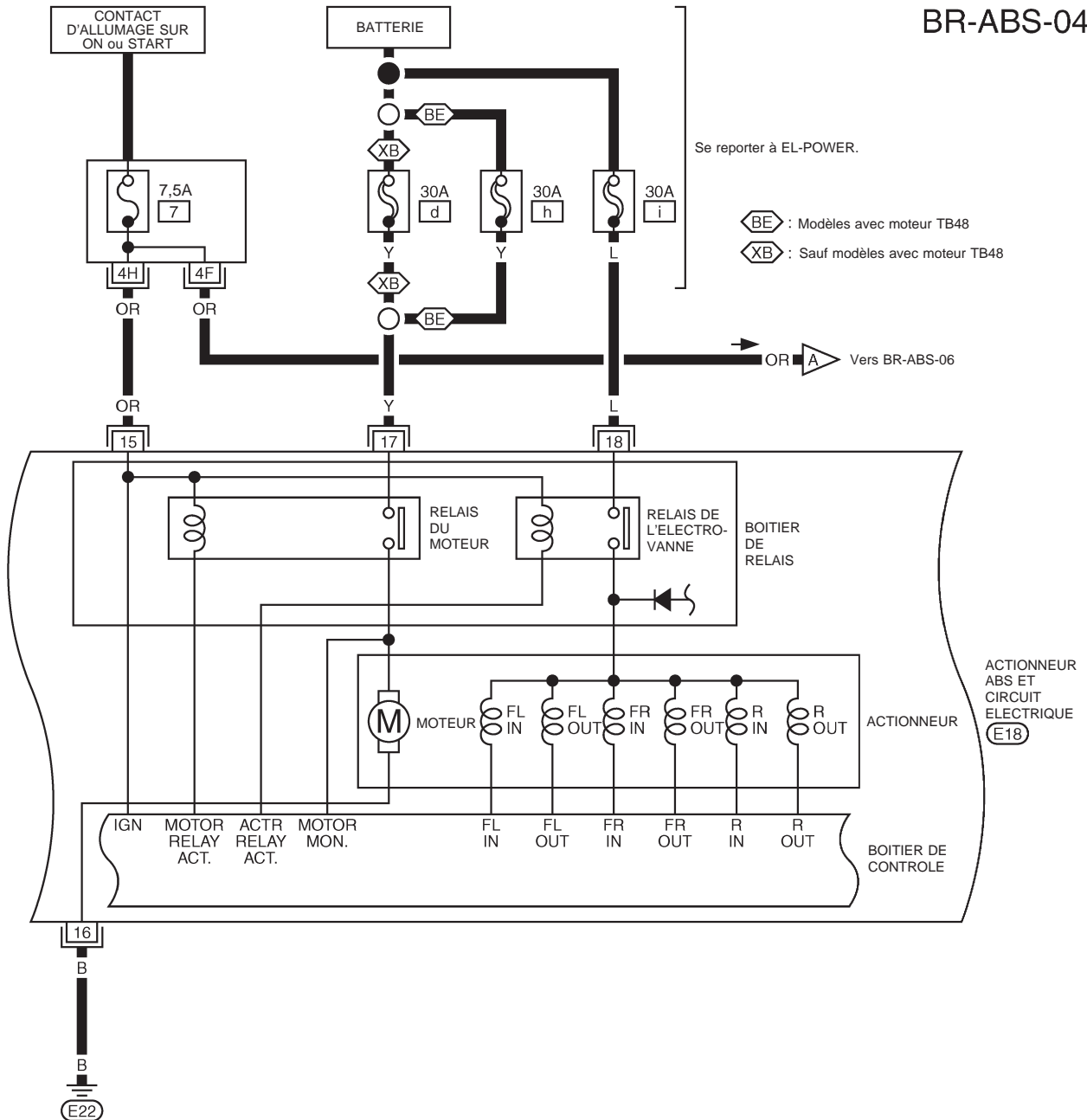

Consulter la dernière page dépliante.

M6

E112

# DIAGNOSTICS DES DEFAUTS

## Schéma de câblage — ABS — (Suite)

BR-ABS-05

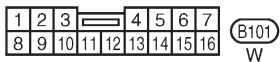
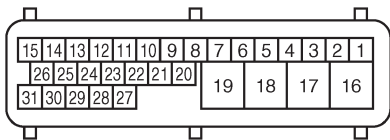
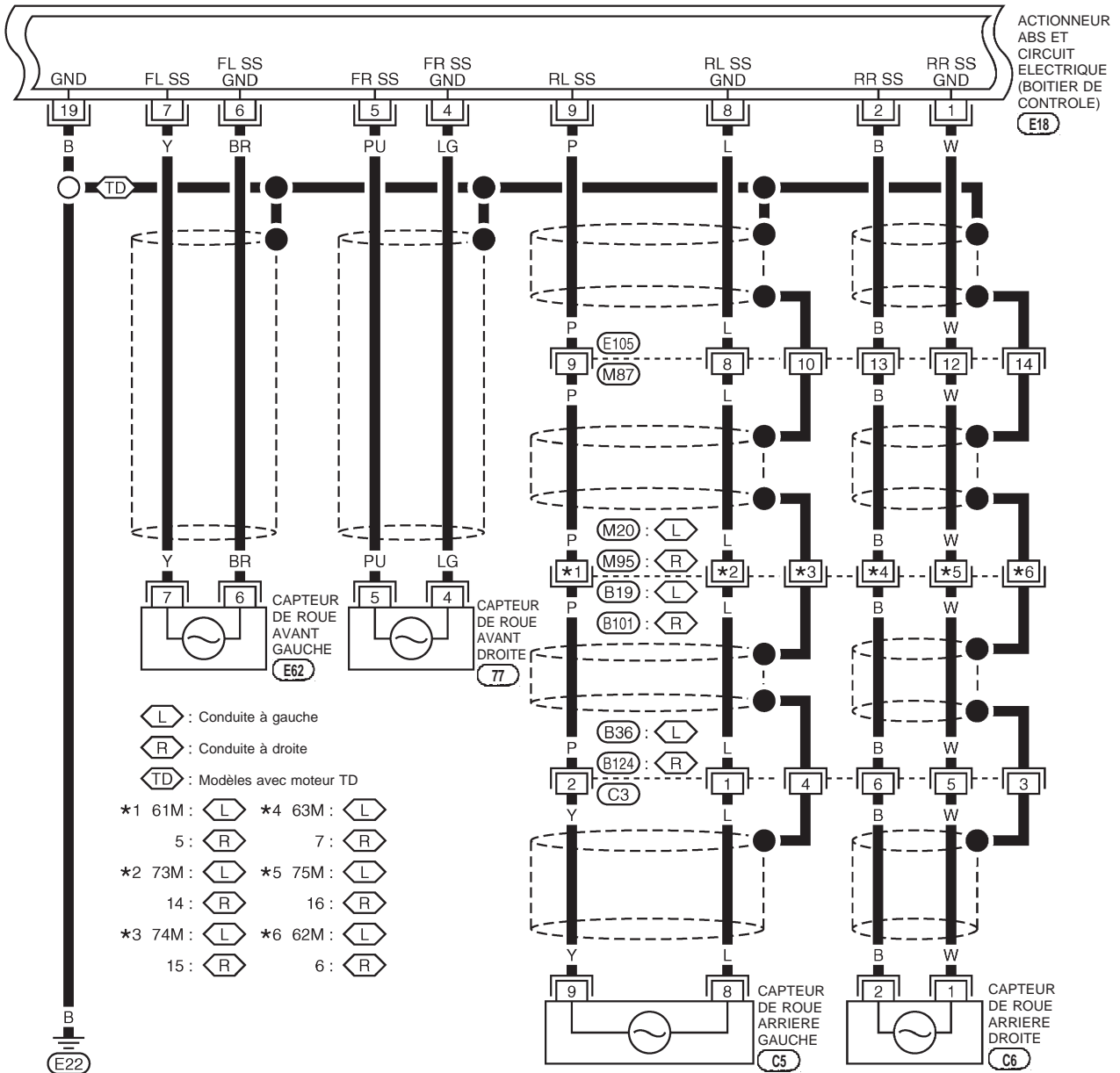

Consulter la dernière page dépliante.

**M20** , **B19**

# DIAGNOSTICS DES DEFAUTS

## Schéma de câblage — ABS — (Suite)

### BR-ABS-06

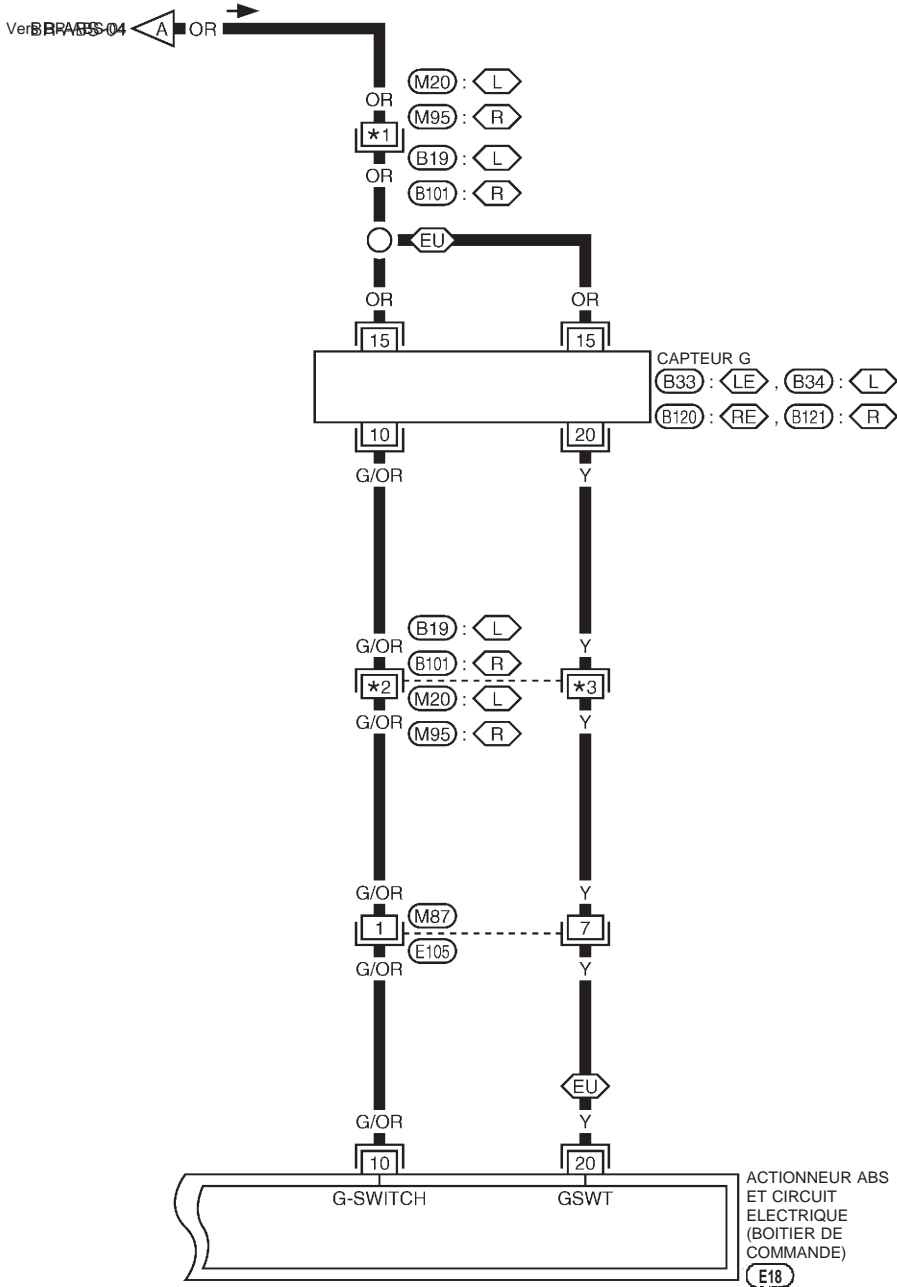

- (L) : Conduite à gauche
- (R) : Conduite à droite
- (EU) : Pour l'Europe
- (LE) : Conduite à gauche pour l'Europe
- (RE) : Conduite à droite pour l'Europe
- \*1 78M : (L)  
11 : (R)
- \*2 76M : (L)  
13 : (R)
- \*3 77M : (L)  
12 : (R)

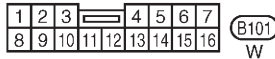
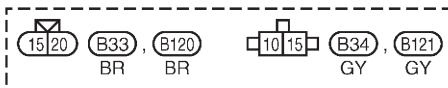
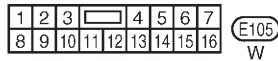
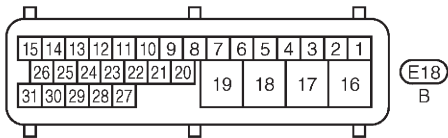

Consulter la dernière page dépliant.

(M20), (B19)