

SYSTEME DE VERROUILLAGE ELECTRIQUE DE PORTE

Schéma de câblage — D/LOCK —

EIS004DE

Vers l'ESM

BL-D/LOCK-01

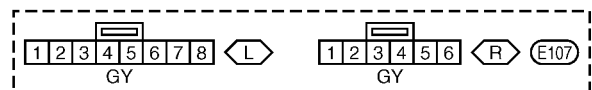
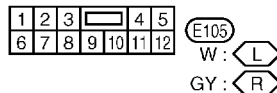
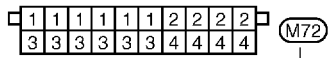
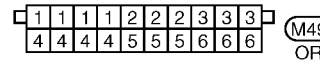
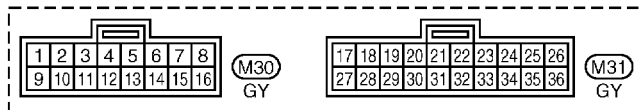
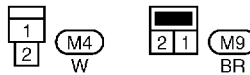
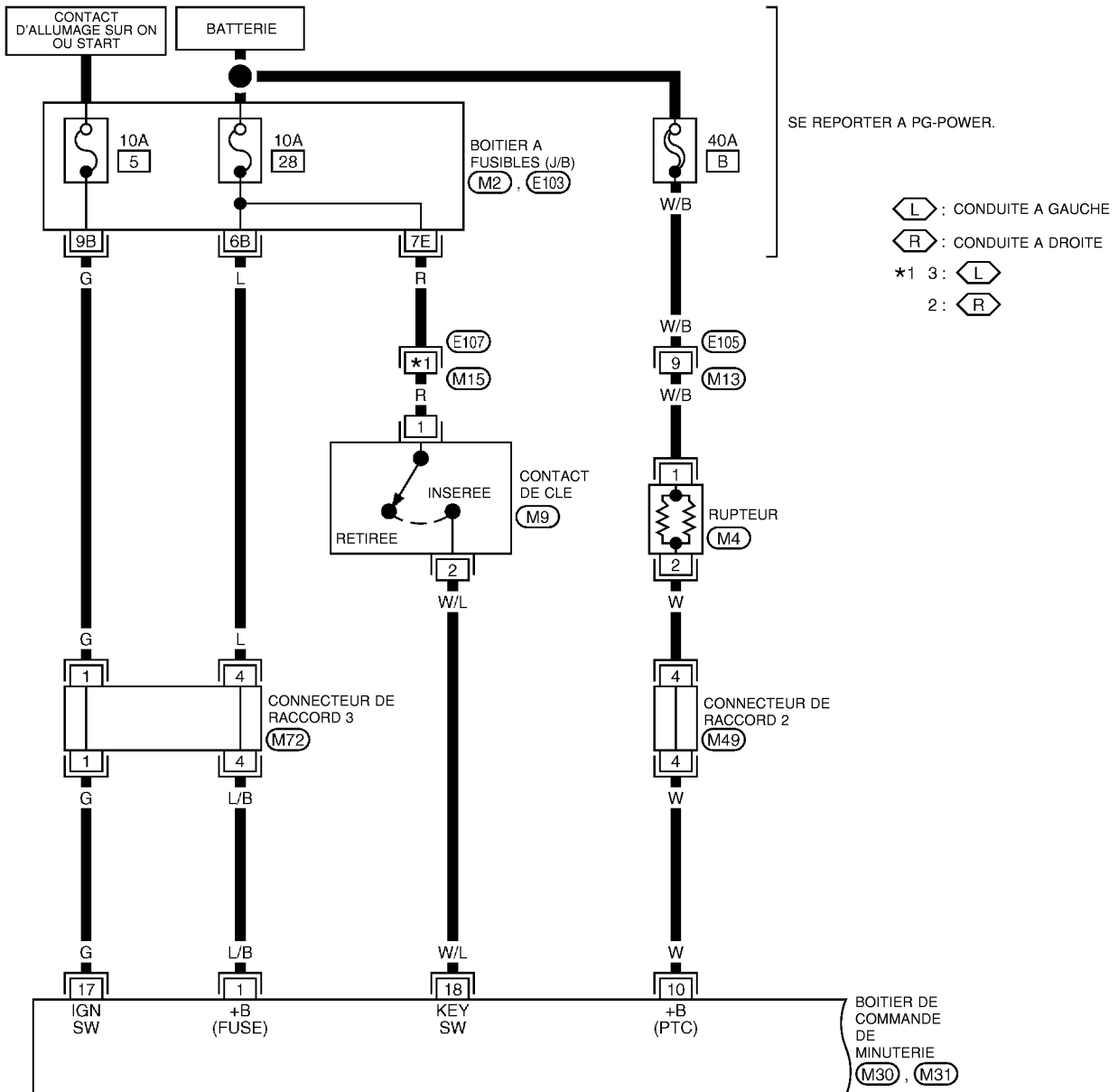

SE REPORTER A CE QUI SUIT.
(M2, E103) -BOITIER A FUSIBLES-
BOITE DE RACCORD (J/B)

A
B
C
D
E
F
G
H
BL
J
K
L
M

TIWA0330E

VERROUILLAGE ELECTRIQUE DE PORTE — SUPERLOCK —

Schéma de câblage — S/LOCK —

EIS001R8

BL-S/LOCK-01

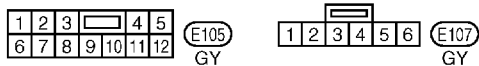
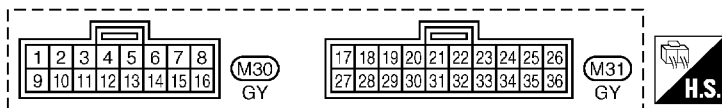
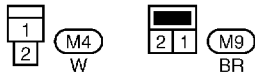
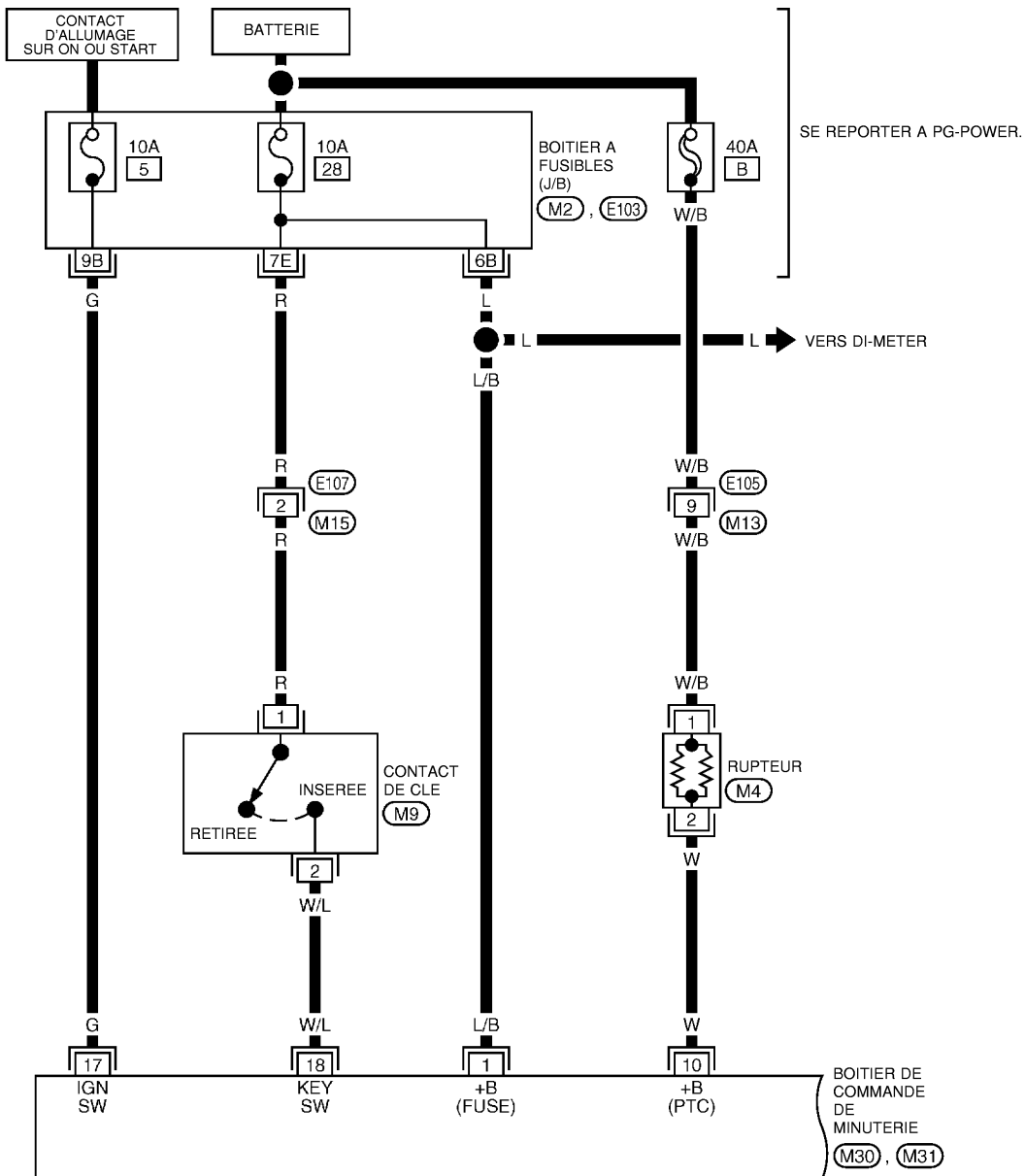

SE REPORTER A CE QUI SUIT.
 (M2), (E103) -BOITIER A
 FUSIBLES-BOITE DE RACCORD
 (J/B)

TIWA0355E

SYSTEME DE TELECOMMANDE A FONCTIONS MULTIPLES

Schéma de câblage — MULTI —

EIS001RF

BL-MULTI-01

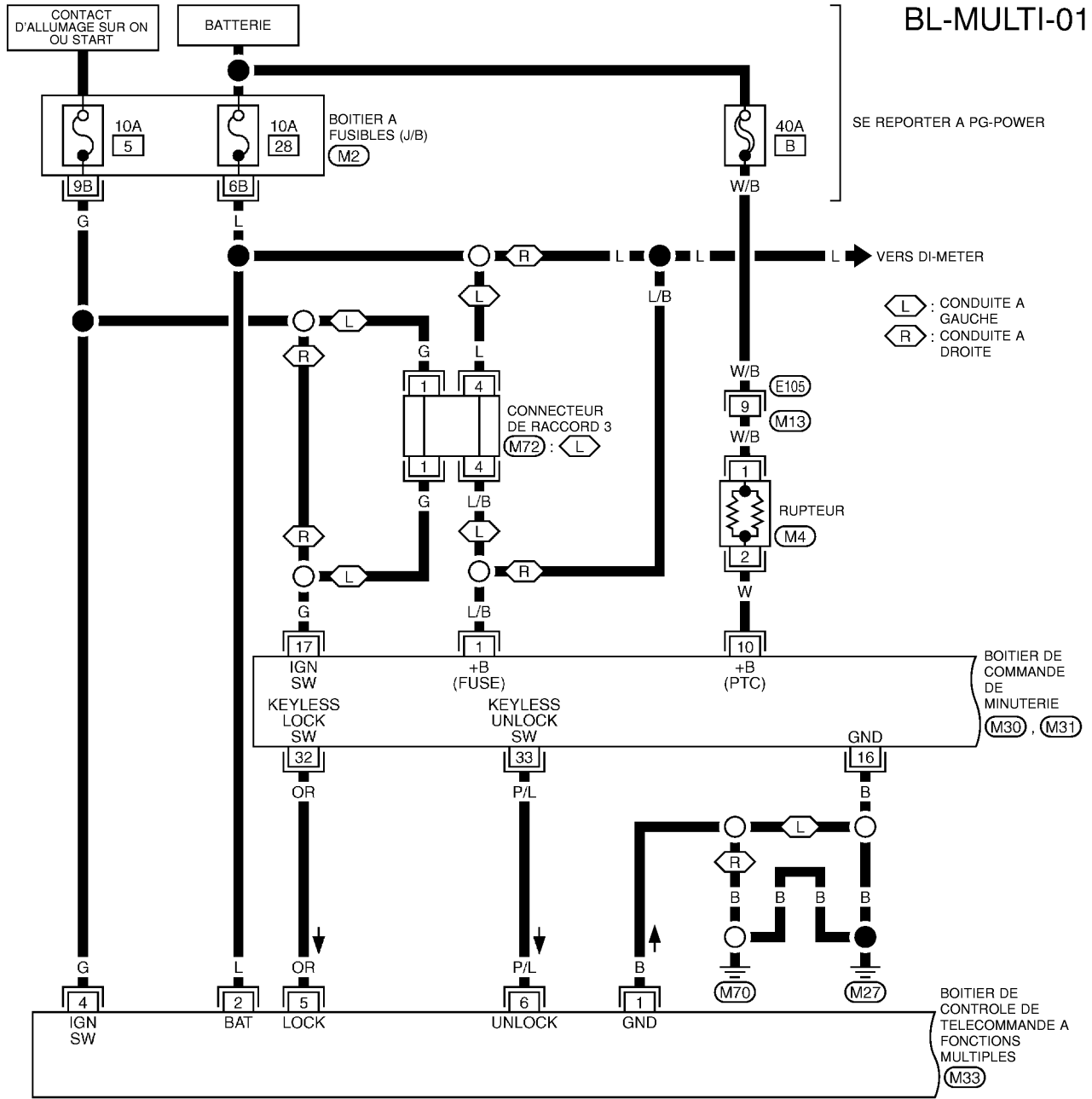

SE REPORTER A PG-POWER

L : CONDUITE A GAUCHE
 R : CONDUITE A DROITE

BOITIER DE COMMANDE DE MINUTERIE (M30, M31)

BOITIER DE CONTROLE DE TELECOMMANDE A FONCTIONS MULTIPLES (M33)

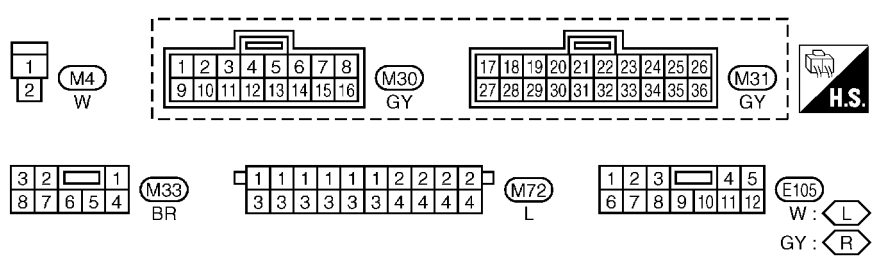

SE REPORTER A CE QUI SUIT.
 M2 - BOITIER A FUSIBLES-BOITE DE RACCORD (J/B)

A
B
C
D
E
F
G
H
BL
J
K
L
M

TIWA0331E

SYSTEME D'AVERTISSEMENT DE VOL

PPF:25362

SYSTEME D'AVERTISSEMENT DE VOL

Schéma de câblage — THEFT —/PRI-WIRE CONDUITE A GAUCHE

EIS001RM

BL-PRWIRE-01

Vers l'ESM

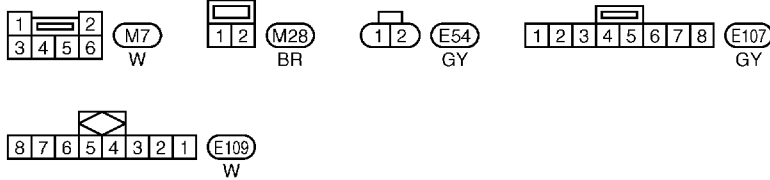
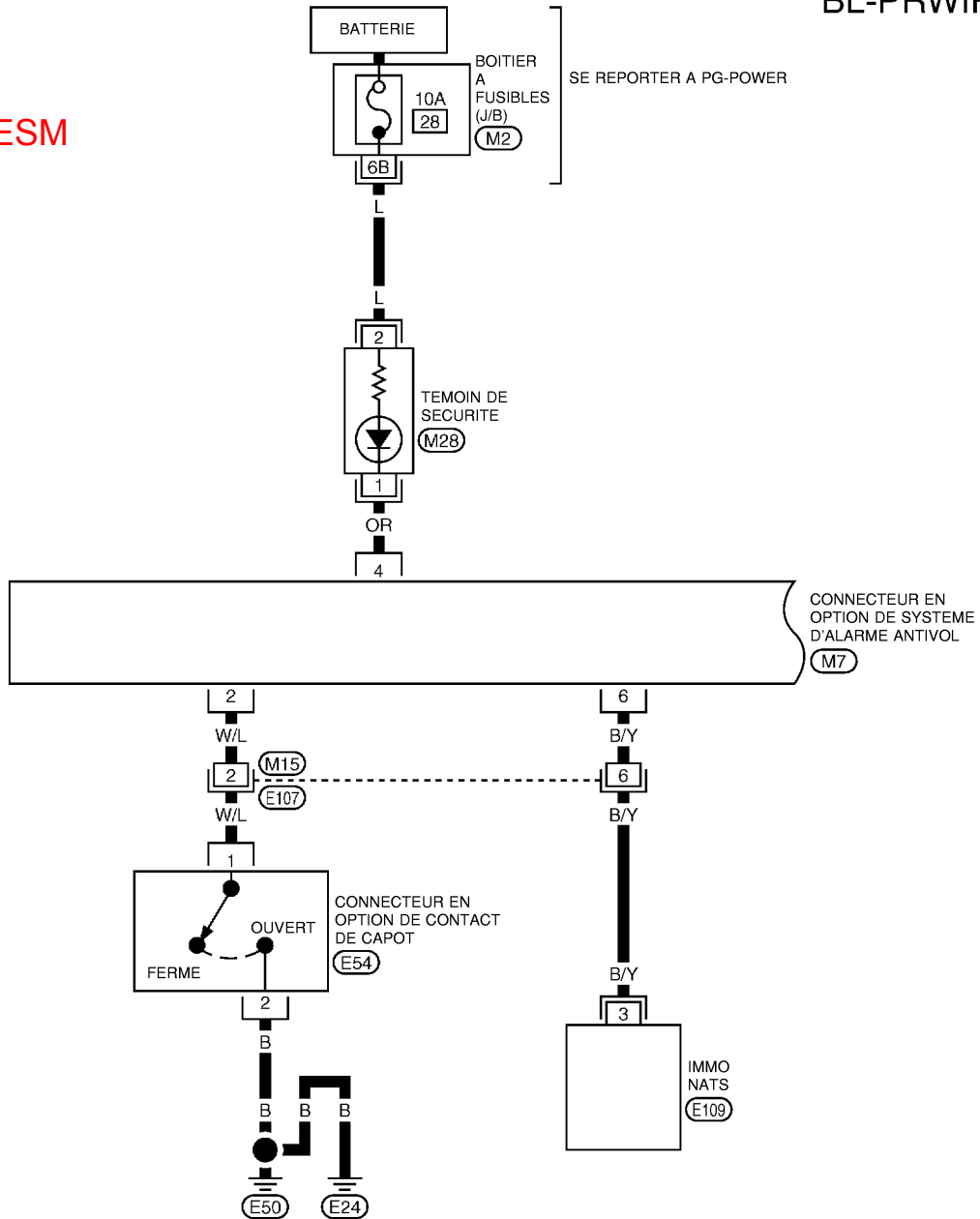

SE REPORTER A CE QUI SUIT.
M2 -BOITIER A FUSIBLES-BOITE
DE RACCORD (J/B)

NATS (SYSTEME ANTIVOL NISSAN)

EIS001RT

Schéma de câblage — NATS — MODELES A MOTEUR A ESSENCE

A
B
C
D
E
F
G
H
BL
J
K
L
M

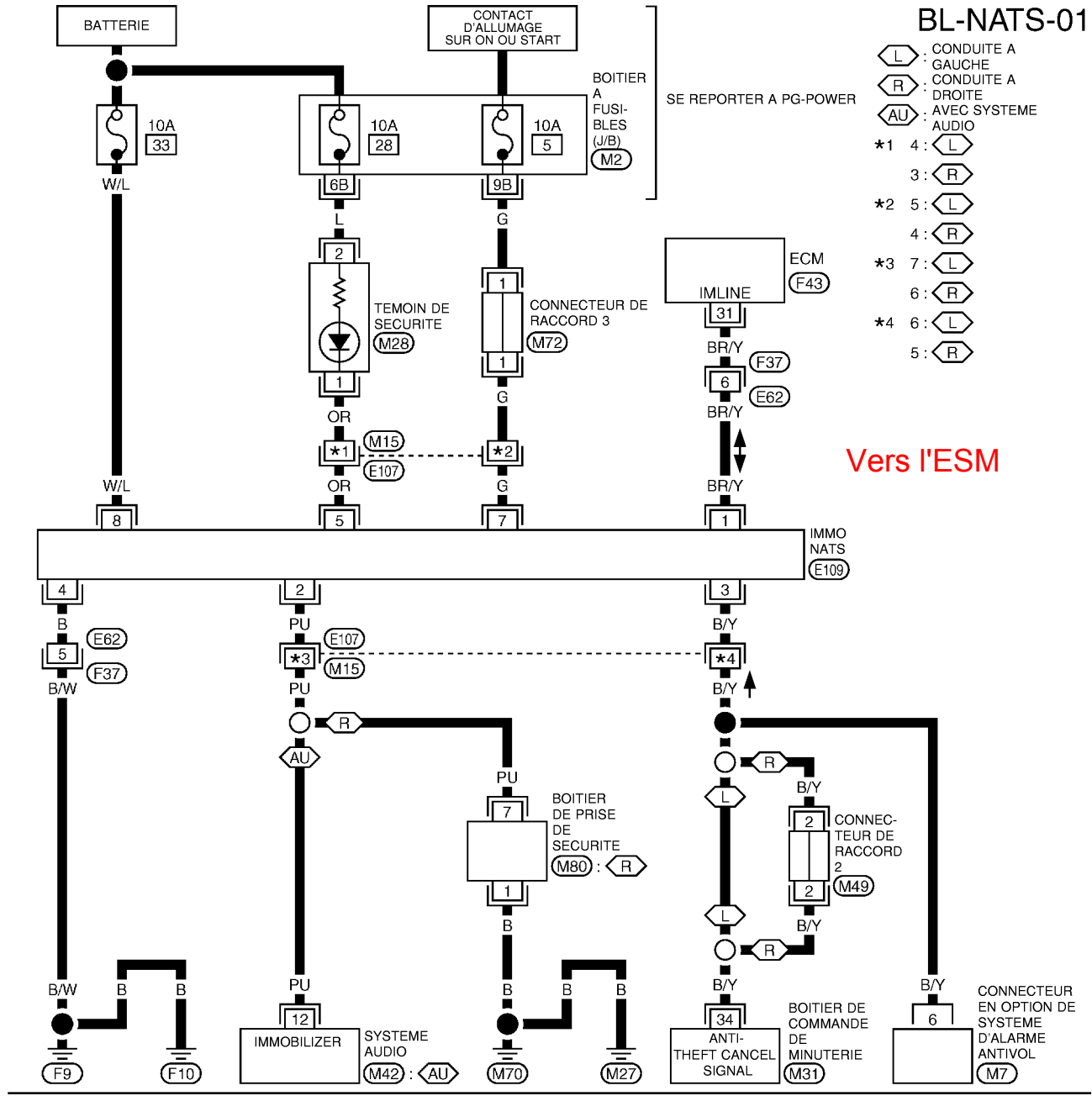

BL-NATS-01

- ⬅ L : CONDUITE A GAUCHE
- ➡ R : CONDUITE A DROITE
- ⬅ AU : AVEC SYSTEME AUDIO
- *1 4 : ⬅ L
- 3 : ➡ R
- *2 5 : ⬅ L
- 4 : ➡ R
- *3 7 : ⬅ L
- 6 : ➡ R
- *4 6 : ⬅ L
- 5 : ➡ R

Vers l'ESM

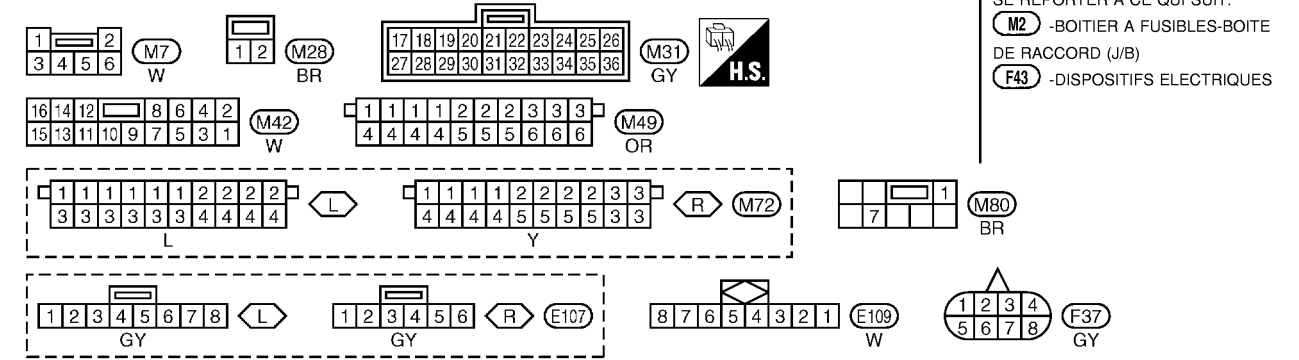

SE REPORTER A CE QUI SUIT.
 (M2) -BOITIER A FUSIBLES-BOITE DE RACCORD (J/B)
 (F43) -DISPOSITIFS ELECTRIQUES

