

## CARACTÉRISTIQUES

### Fusibles

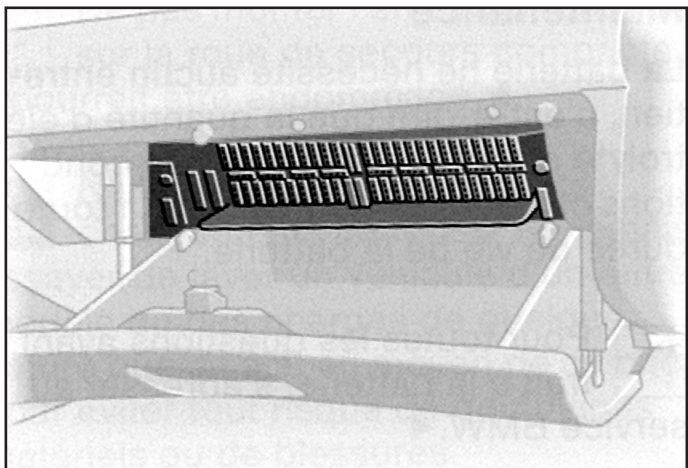

- Si un appareil électrique tombe en panne, arrêtez-le et contrôlez son fusible.
- Ouvrir la boîte à gants et tourner les deux verrous rapides blancs vers l'extérieur. Des fusibles de réserve et une pincette en matière plastique se trouvent sur la réglette de fusibles.
- Extraire le fusible du consommateur défectueux de sa prise à l'aide de la pincette en matière plastique.
- Remplacer un fusible grillé - reconnaissable au fil fondu - par un fusible neuf de même couleur, c'est à dire de même ampérage.
- Le répertoire des fusibles avec ampérage et consommateurs correspondants se trouve sous la réglette de fusibles.
- Pour refermer la réglette de fusibles, exercer une pression sur le haut du couvercle et tourner les deux verrous rapides vers l'intérieur.

**Nota** : ne pas tenter de réparer des fusibles grillés ou les remplacer par des fusibles d'une autre couleur ou d'un autre ampérage, car une surcharge des câbles électriques pourrait provoquer un incendie dans la voiture.

### Alternateur

Tension nominale	V	14
Courant/puissance nominal(e)	A/W	65/910 70/980 80/1120 90/1260 105/1470 115/1610 140/1960
Capacité du condensateur d'antiparasitage	μF	2,2 ±20%

### Régulateur

- Stabilisation de tension (V) ..... **14,3**

### Démarrreur

Jeu axial de l'induit	mm	0,1...0,2
Longueur des balais de charbon	mini mm	-
Tension d'essai	V	12 ±0,3

### Contacteur à solénoïde

<b>Consommation de courant à la borne 50 (sous tension nominale)</b>		
Avec une puissance nominale de 1,4 kW :		
enroulement d'appel	A	54,5
enroulement de maintien	A	10,5
Avec une puissance nominale de 1,8 kW :		
enroulement d'appel	A	50
enroulement de maintien	A	12
Tension d'attraction à 20°C	A	7,4

## SCHÉMAS ÉLECTRIQUES

### Explication des symboles des schémas électriques et des couleurs des câbles

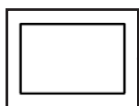

Composant complet

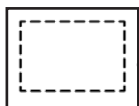

Partie d'un composant

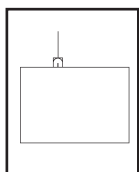

Connecteur raccordé au composant

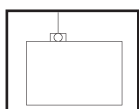

Composant avec borne à vis

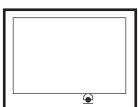

Boîtier du composant directement relié à la masse du véhicule

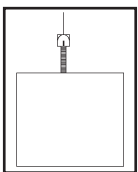

Connecteur raccordé au câble de connexion du composant

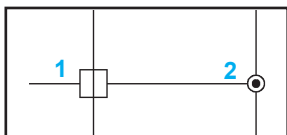

1 croisement de deux fils (sans contact)  
2 jonction de deux fils

### Couleur des câbles

BL	Bleu
BR	Brun
GE	Jaune
GN	Vert
GR	Gris
OR	Orange
RS	Rose

RT	Rouge
SW	Noir
VT	Violet
WS	Blanc
TR	Transparent

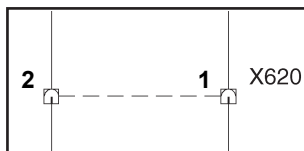

- Deux broches à l'intérieur d'un même connecteur.
- La ligne en pointillée désigne les points de connexion du même connecteur.

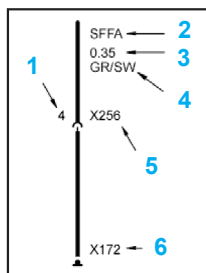

- (1) Numéro de broche
- (2) Signal
- (3) Section de câble en mm<sup>2</sup>
- (4) Couleur de câble
- (5) Numéro de référence du connecteur
- (6) Numéro de référence de la masse

## Gestion moteur MS43 (DME Electronique moteur MS43)

## Préparation du mélange/allumage

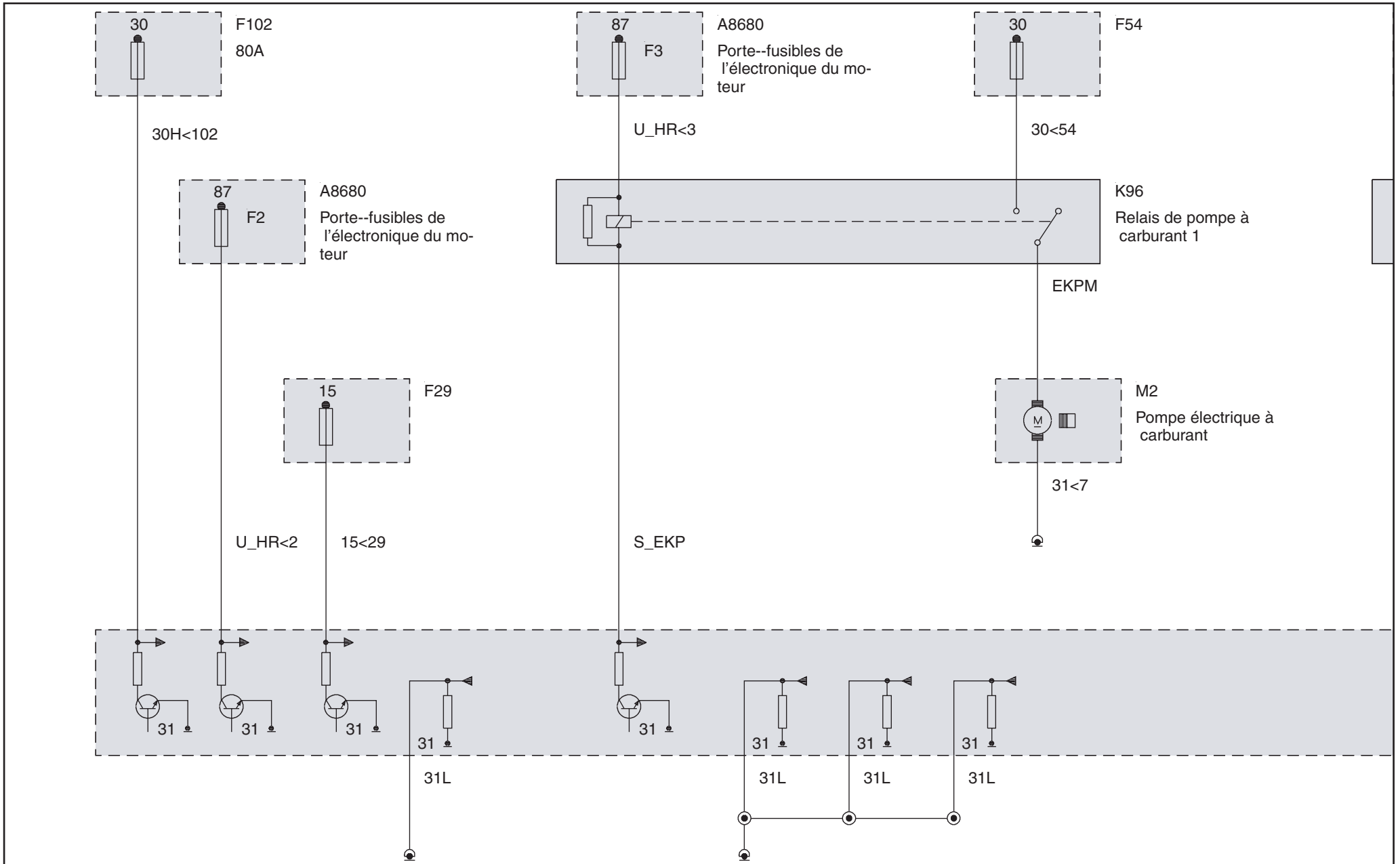

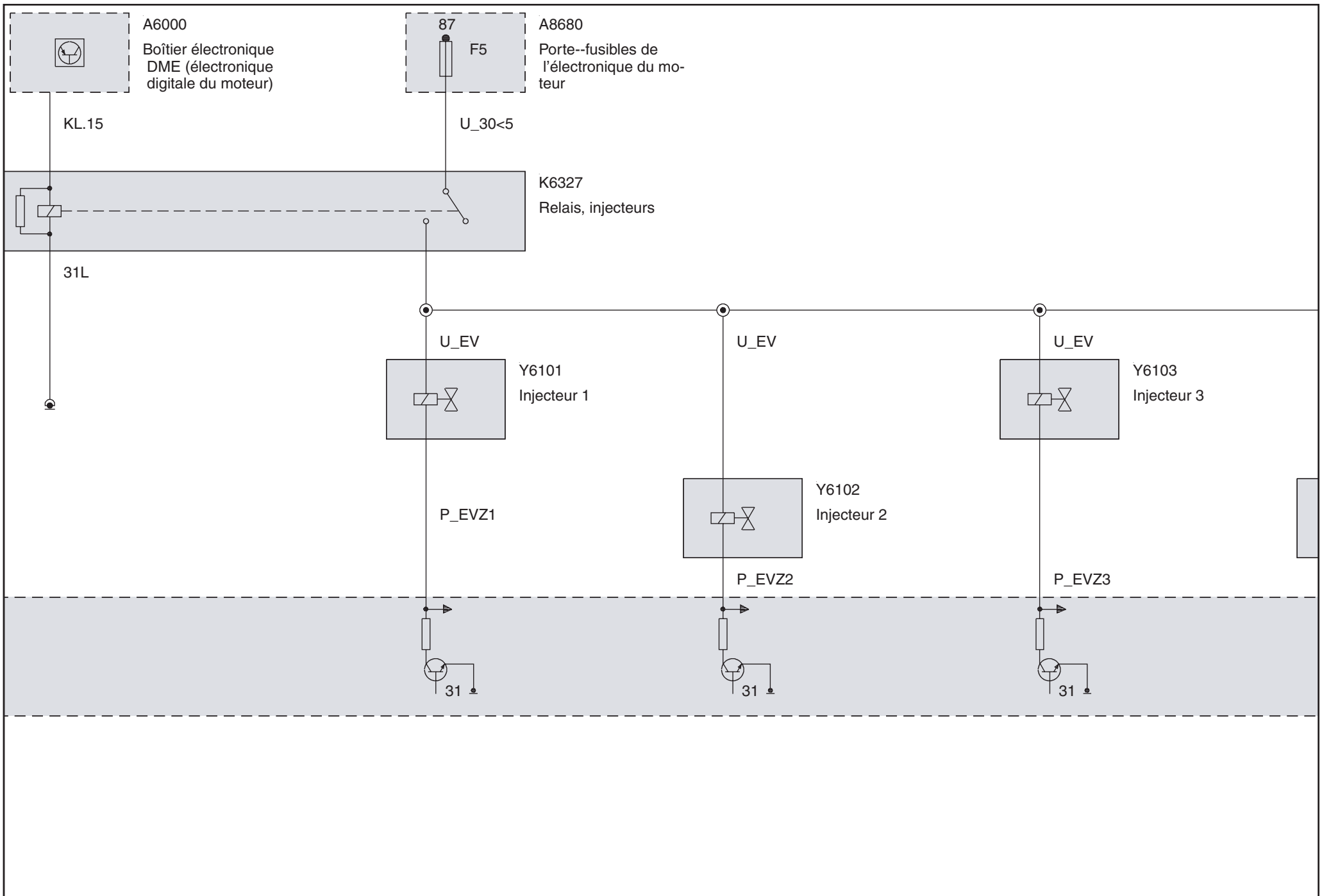

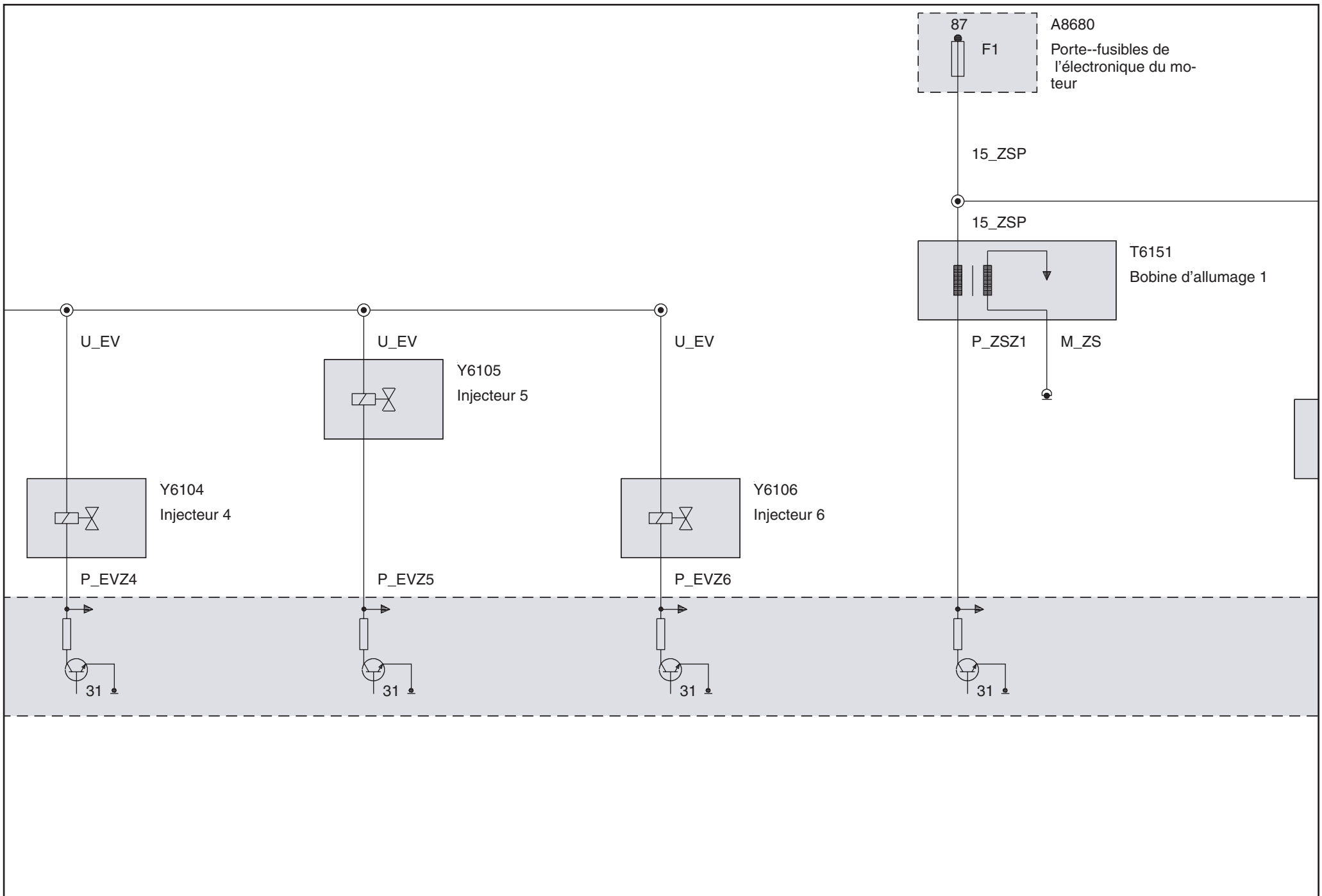

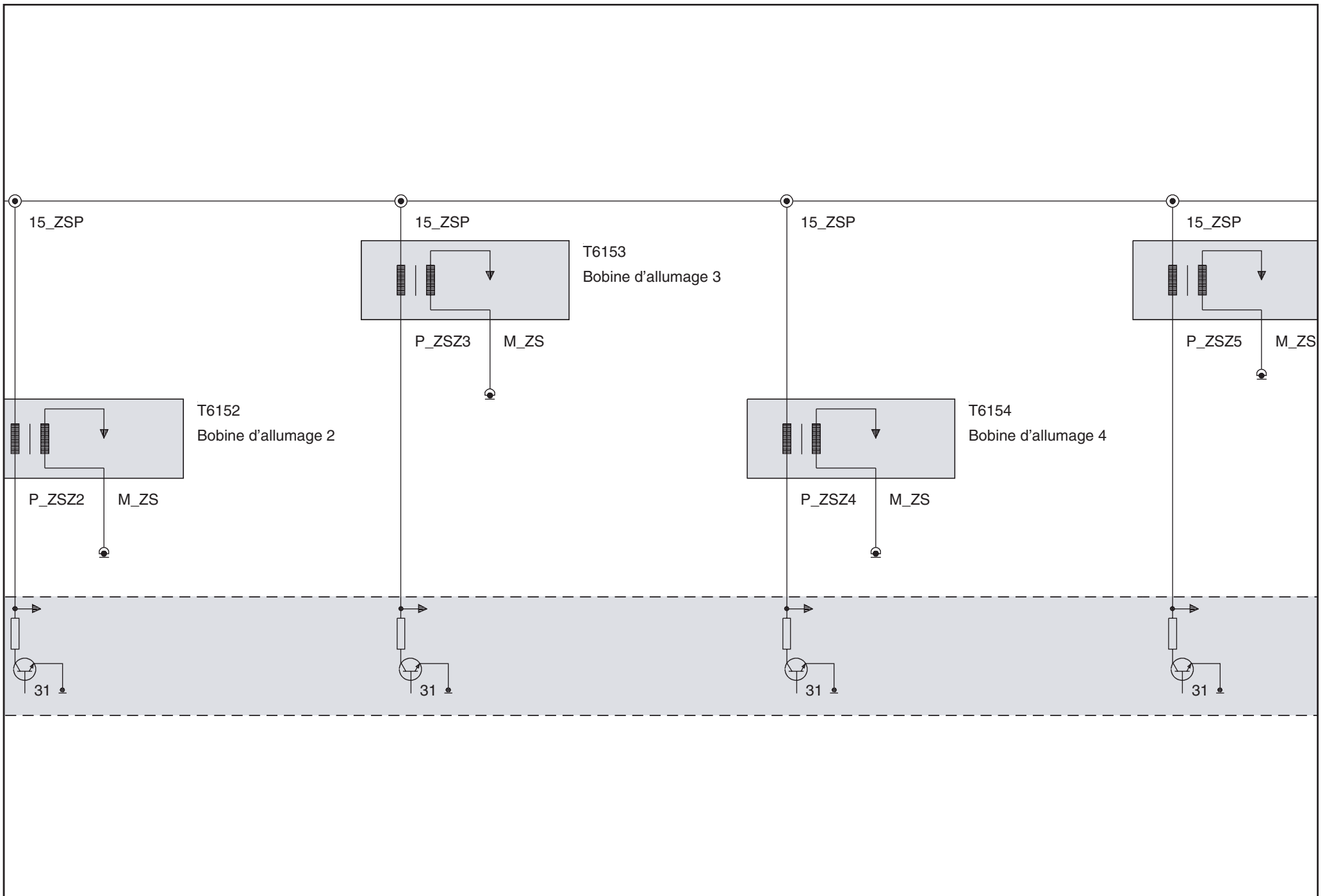

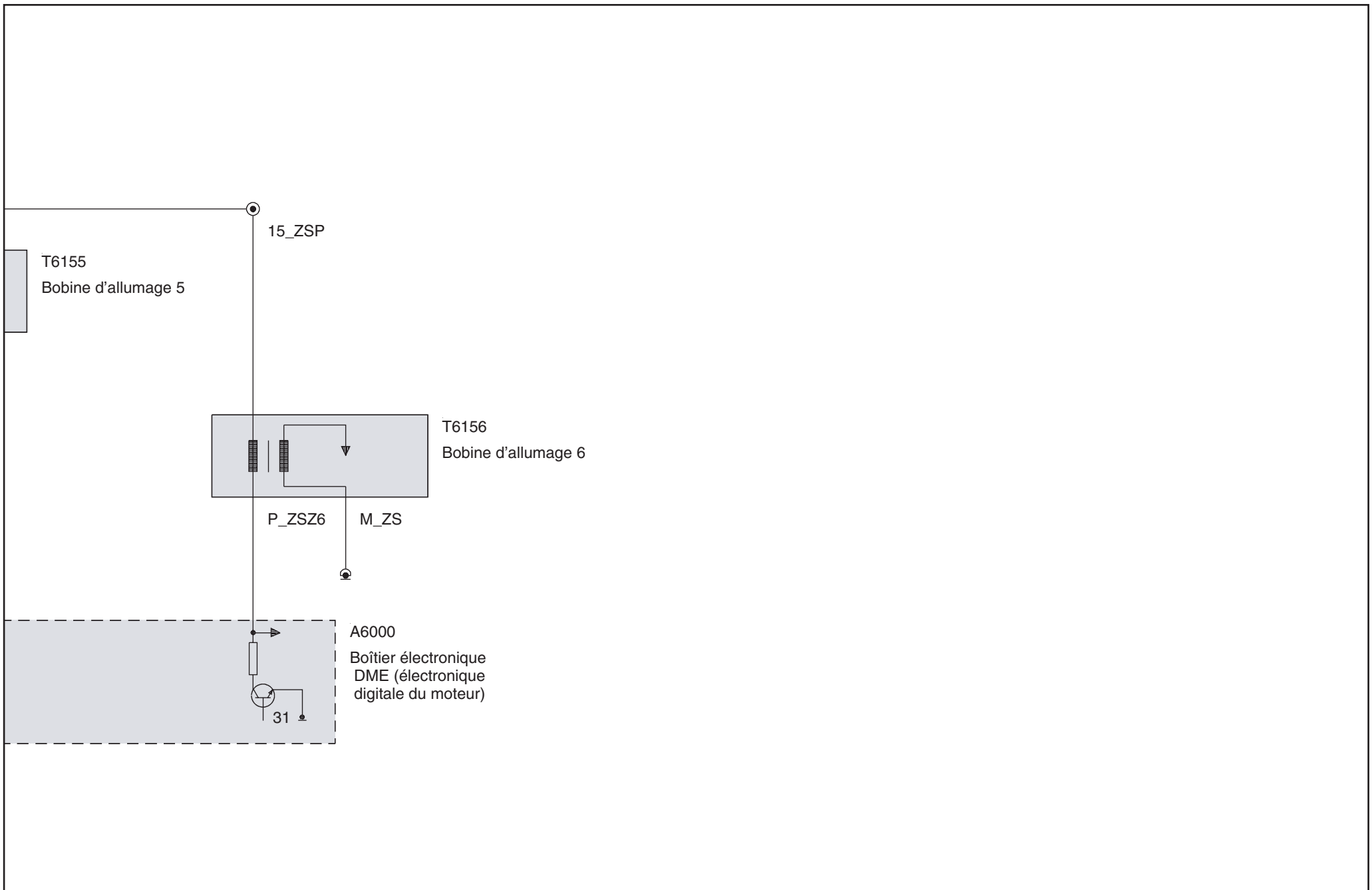

Paramètres d'entrée mélange/allumage

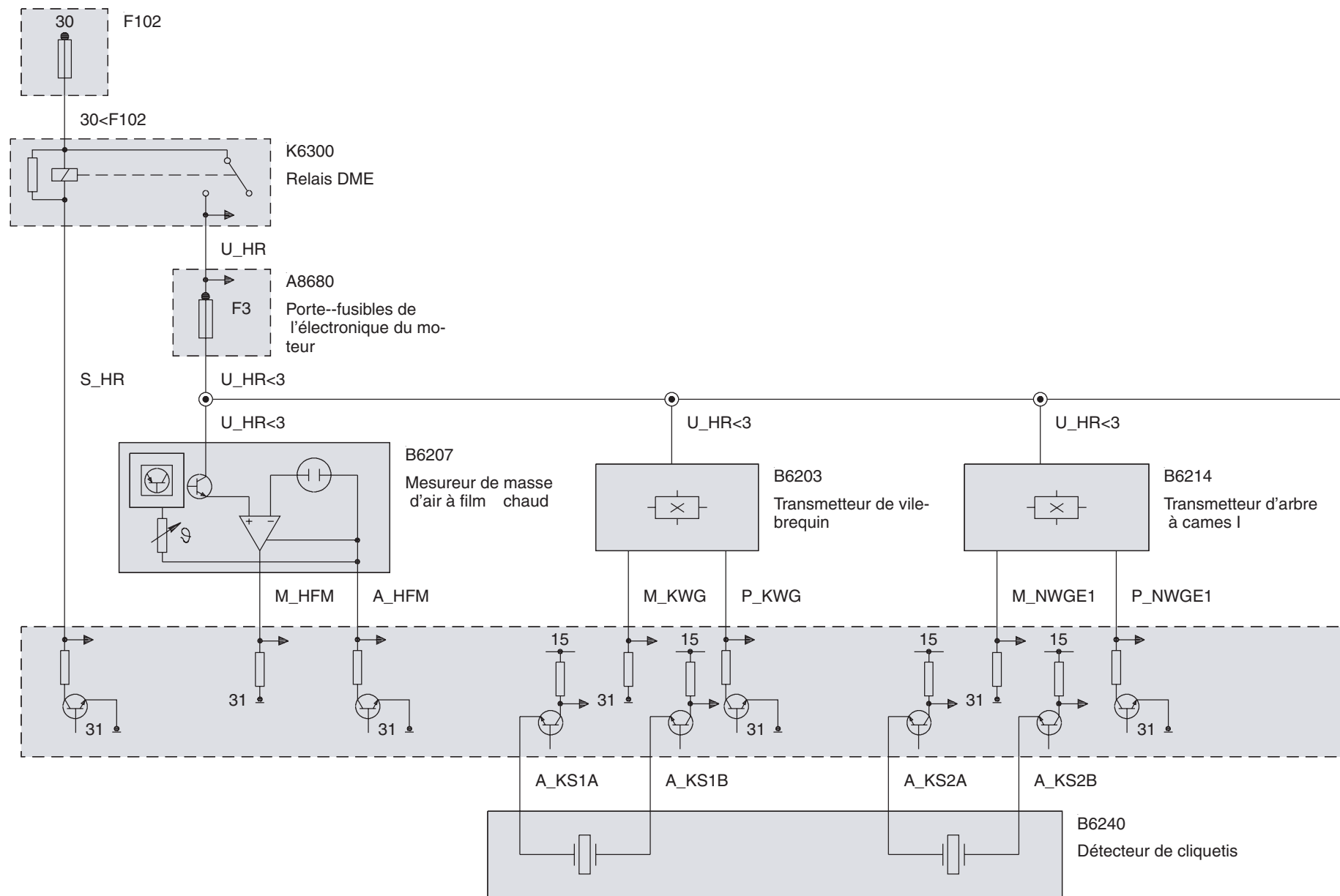

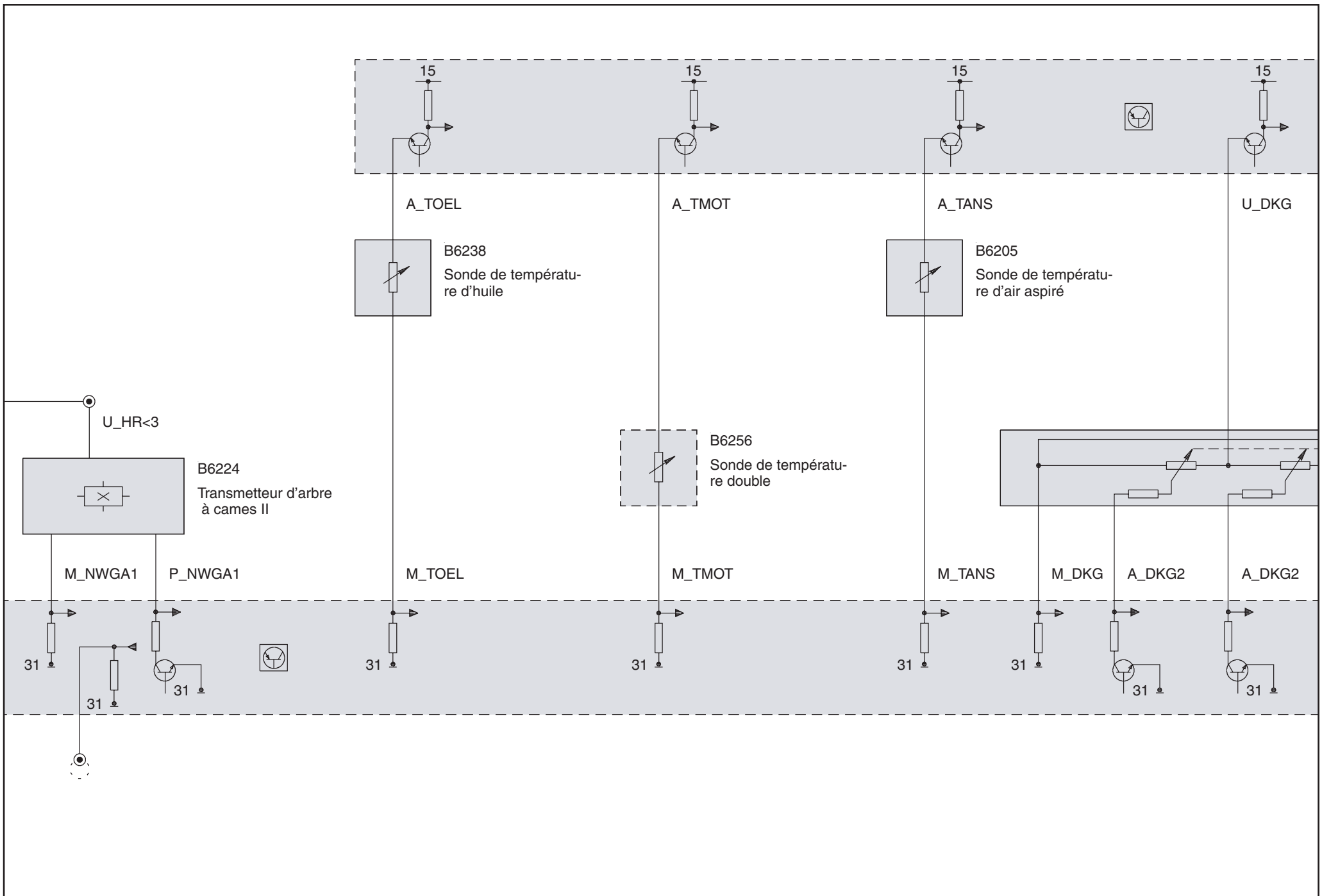



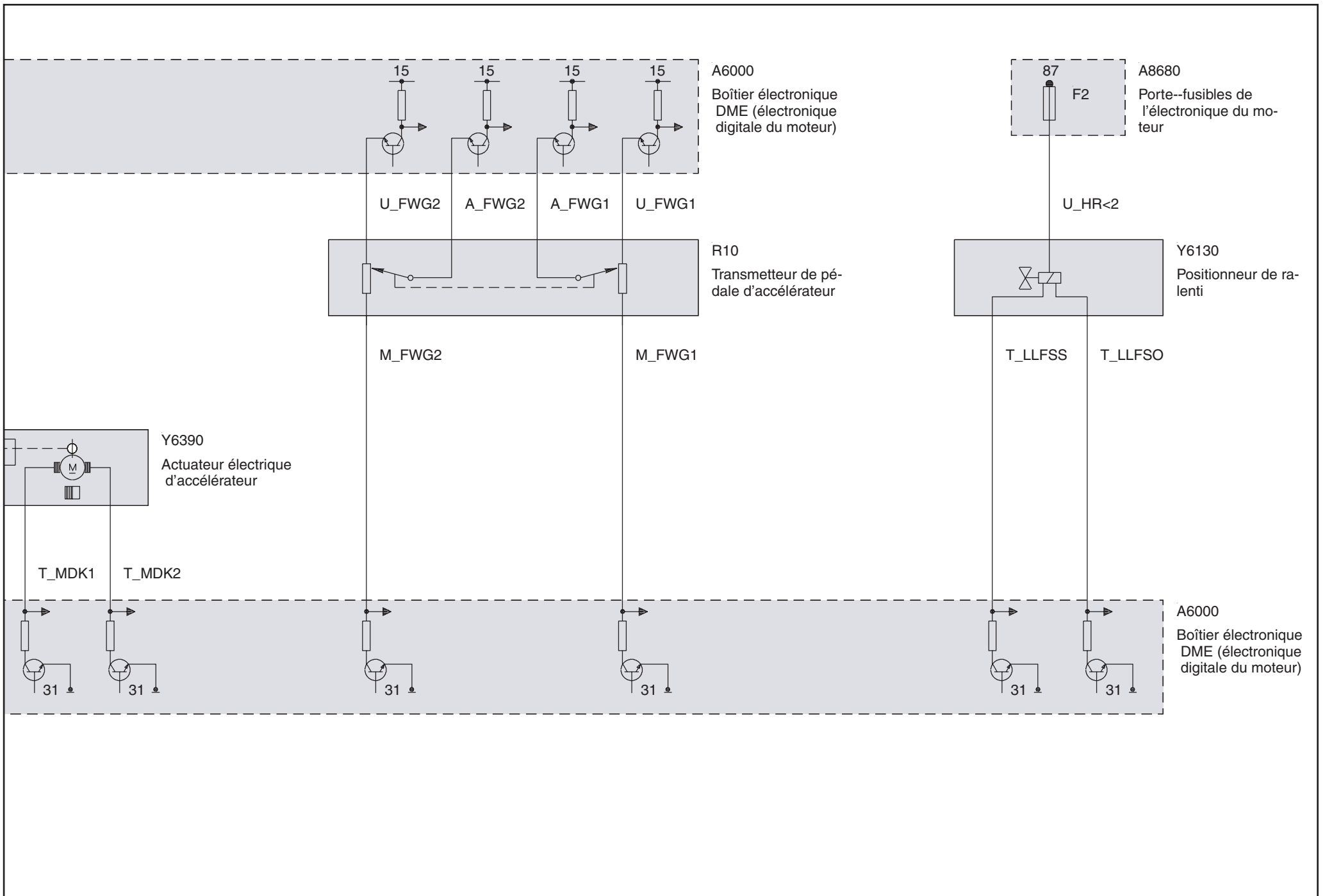

Commande du moteur, fonctions auxiliaires

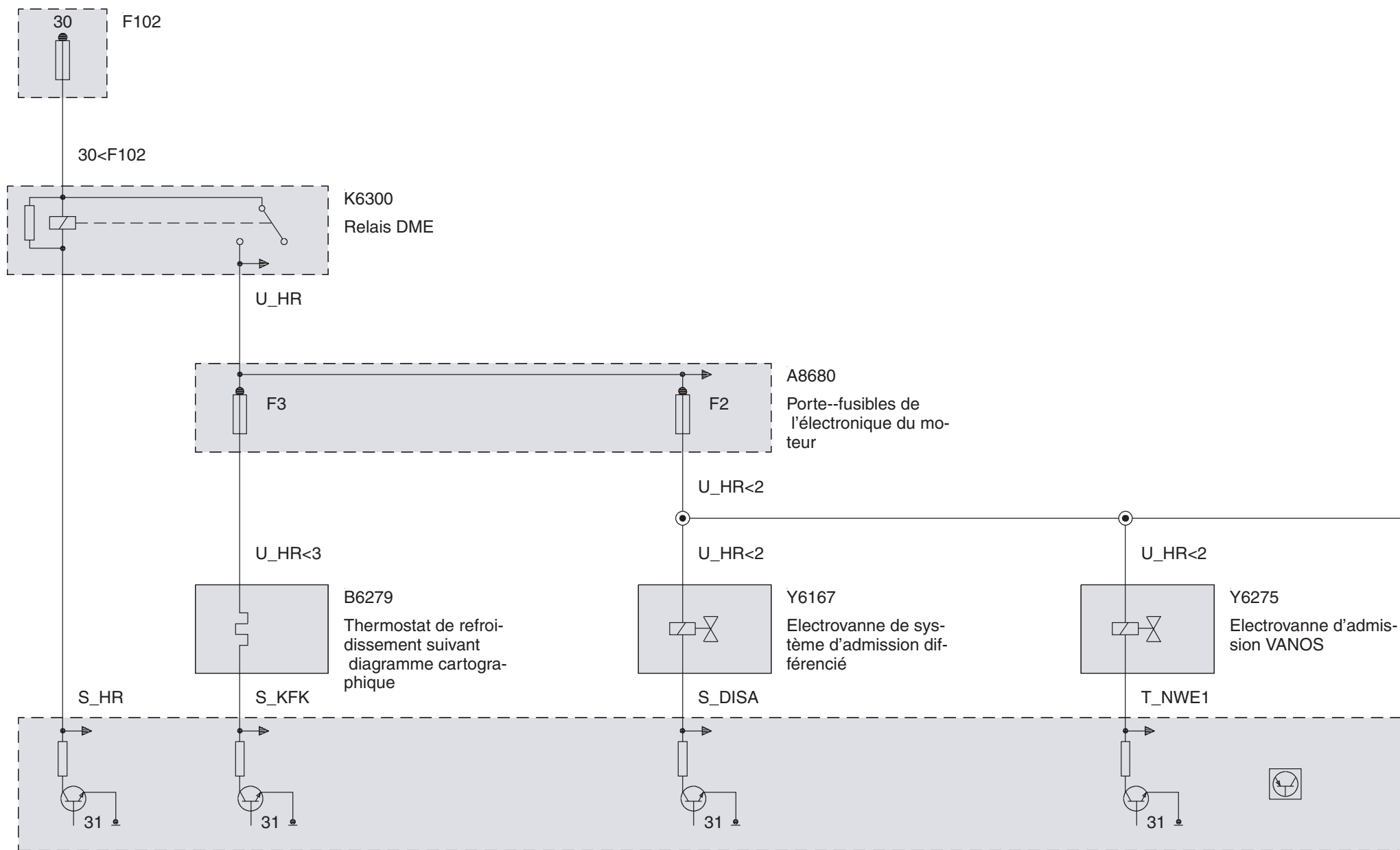

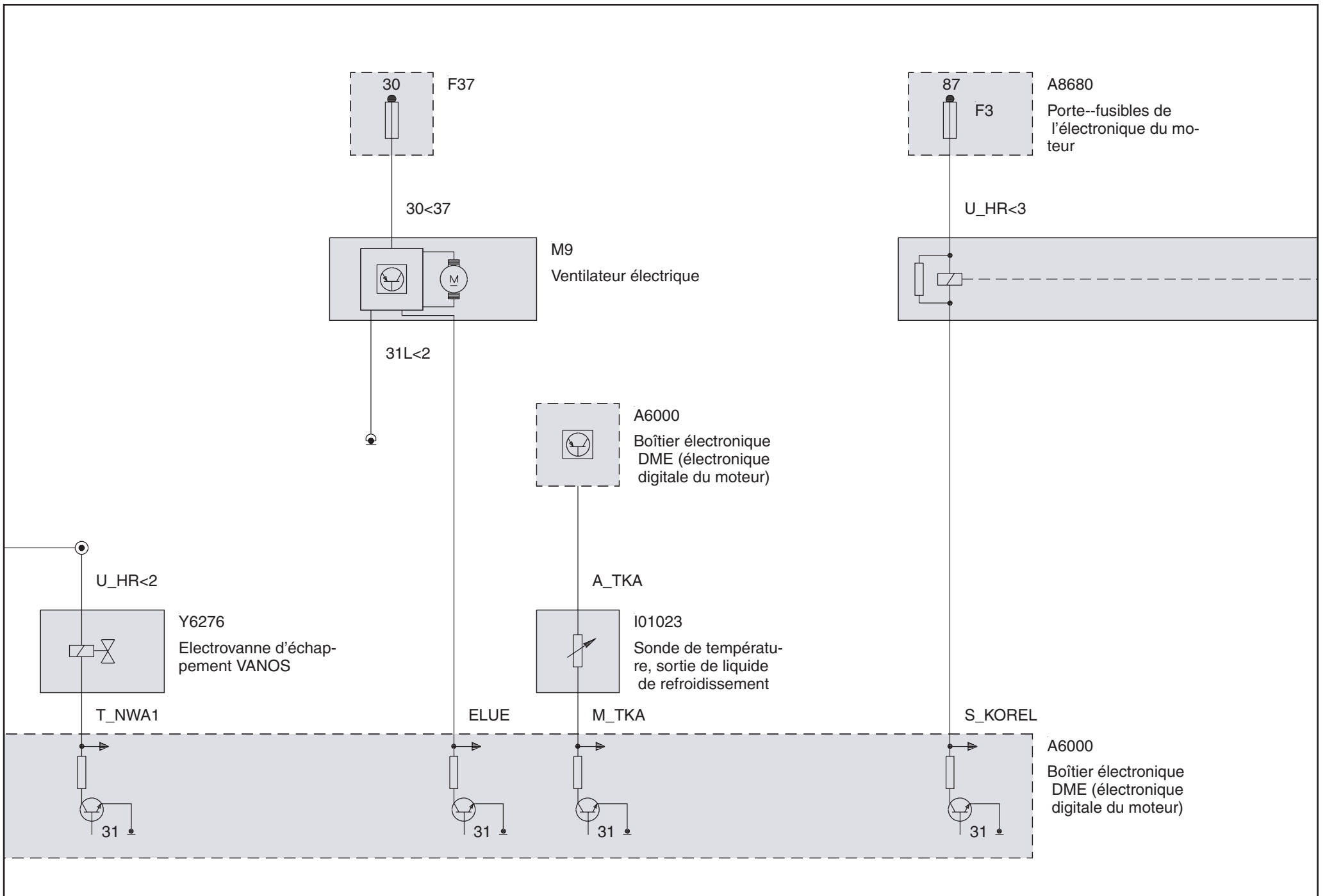

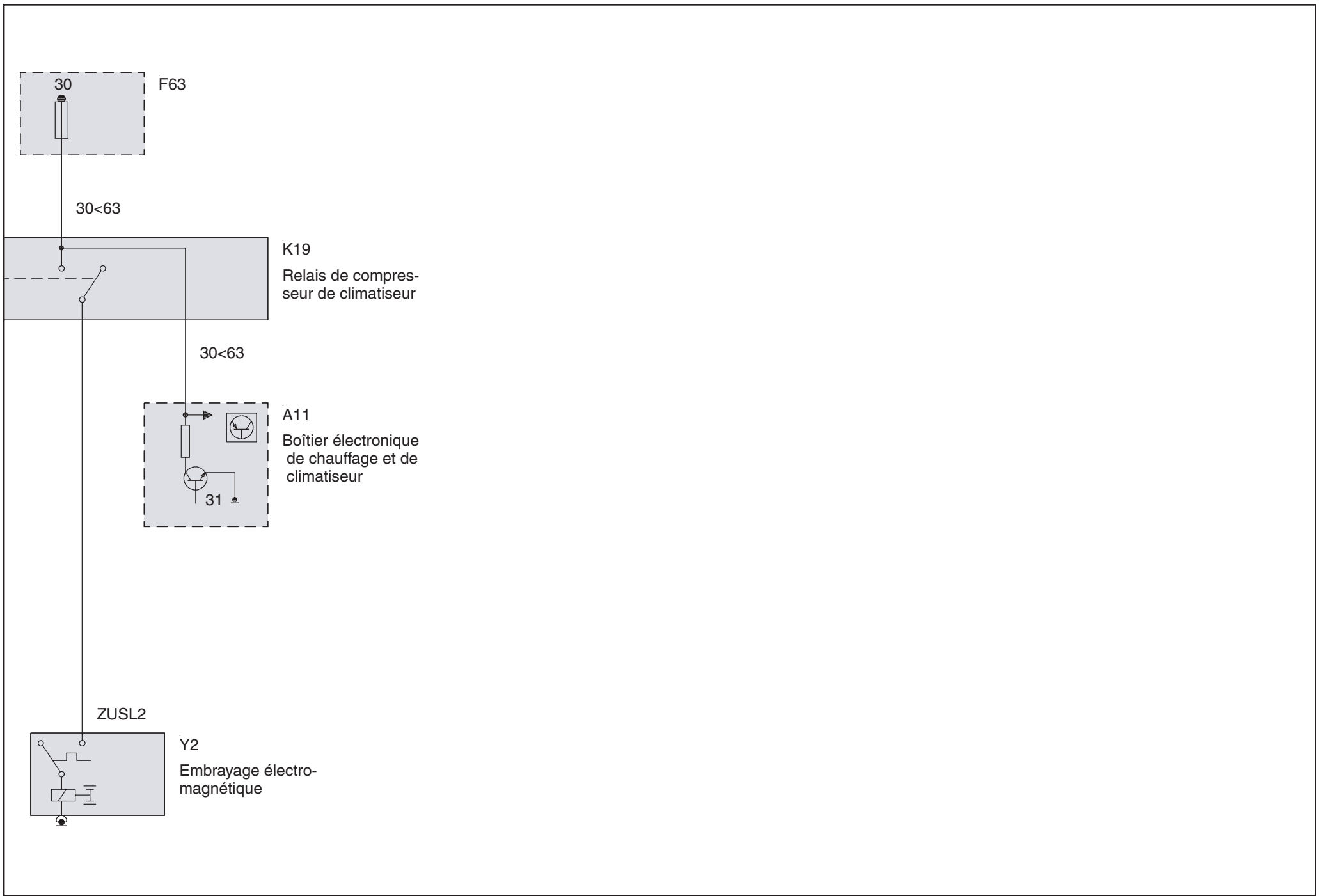

Régulation/épuration/contrôle des gaz d'échappement

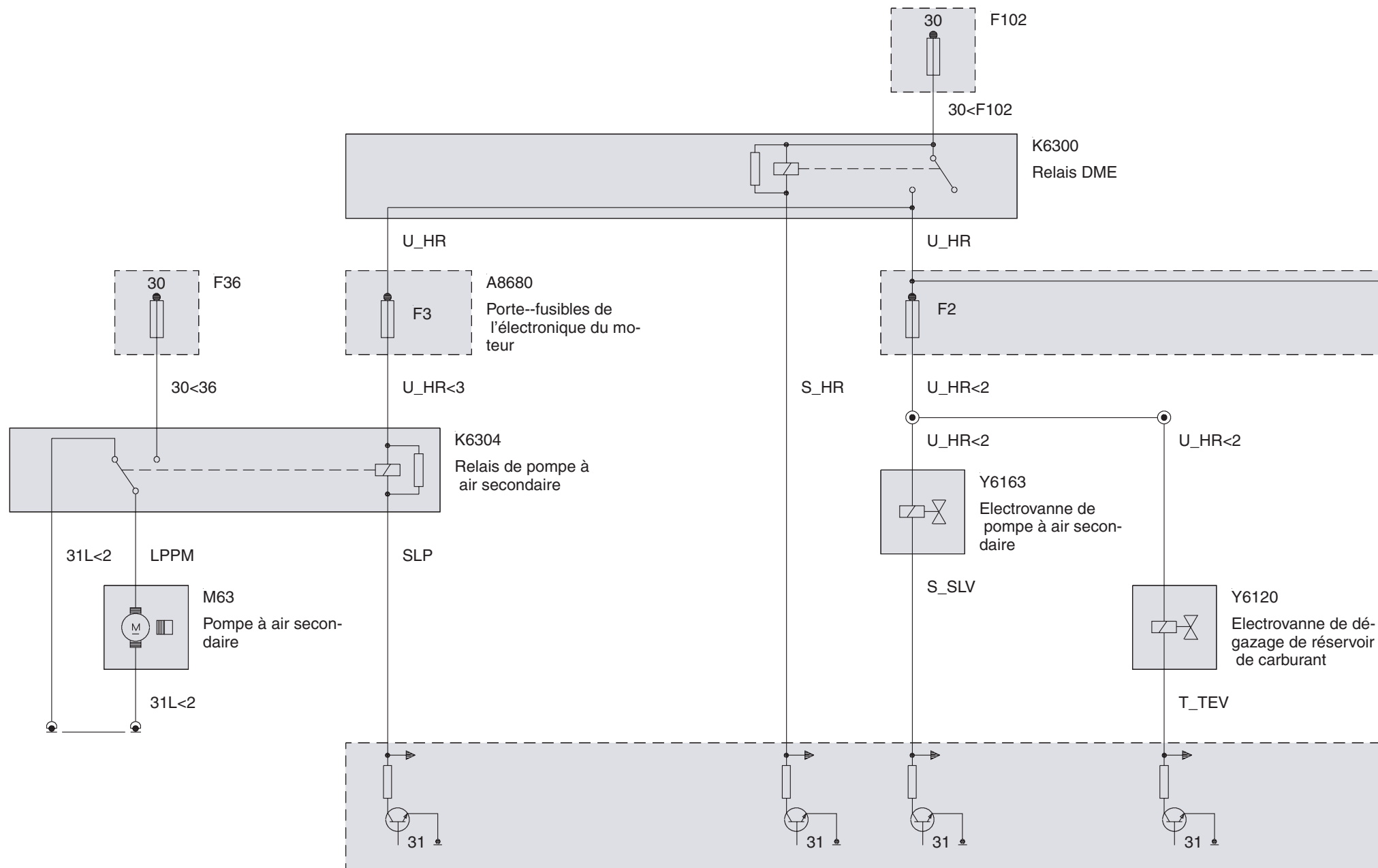

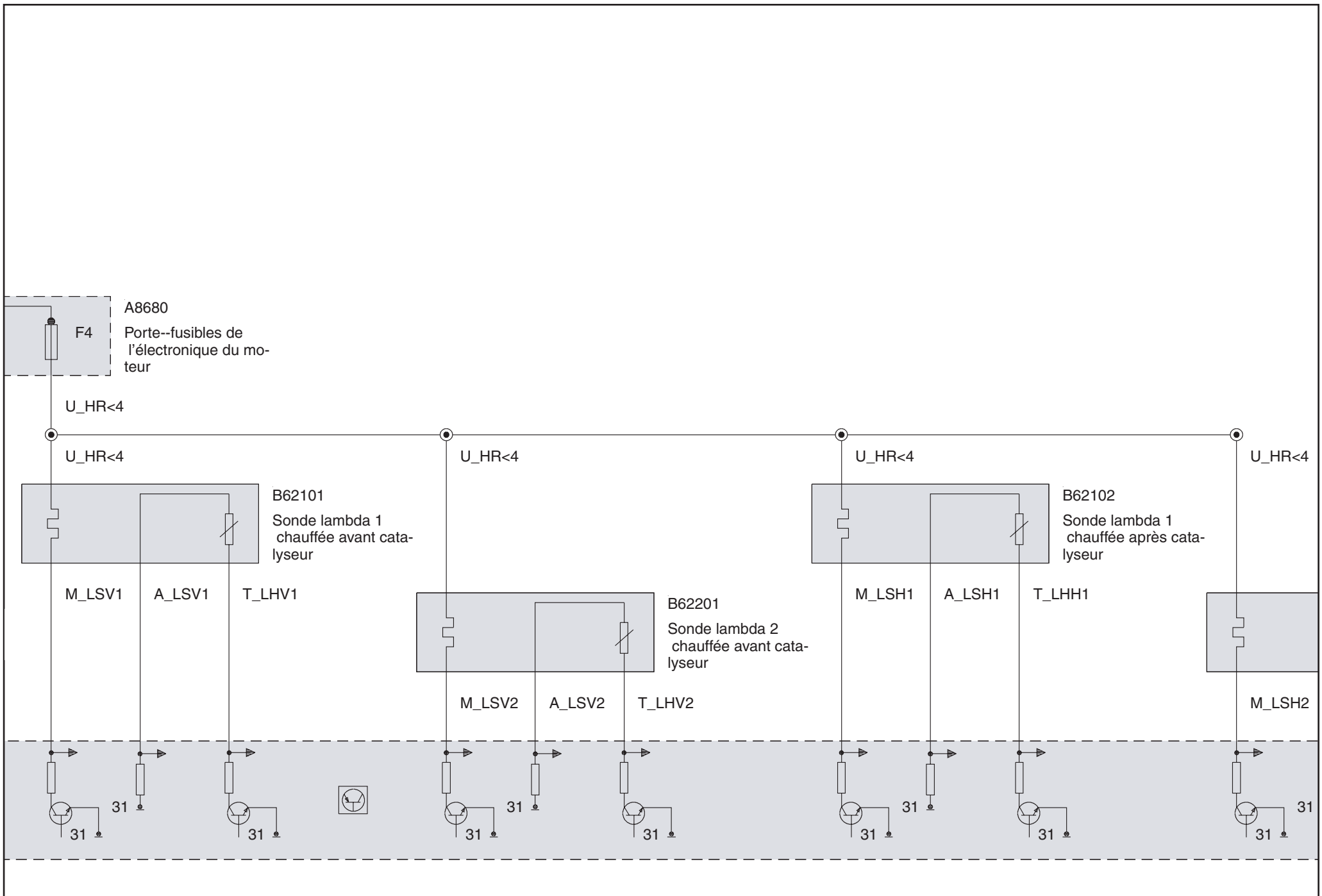

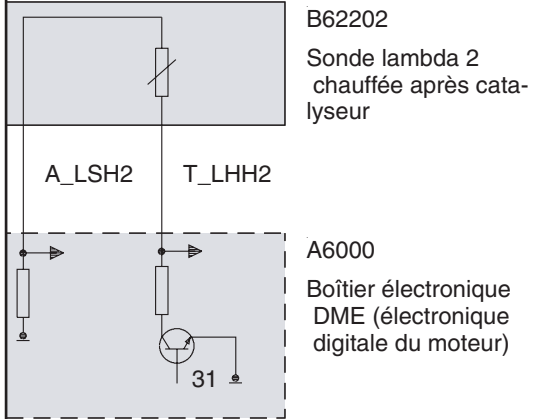

B62202  
Sonde lambda 2  
chauffée après cata-  
lyseur

A6000  
Boîtier électronique  
DME (électronique  
digitale du moteur)





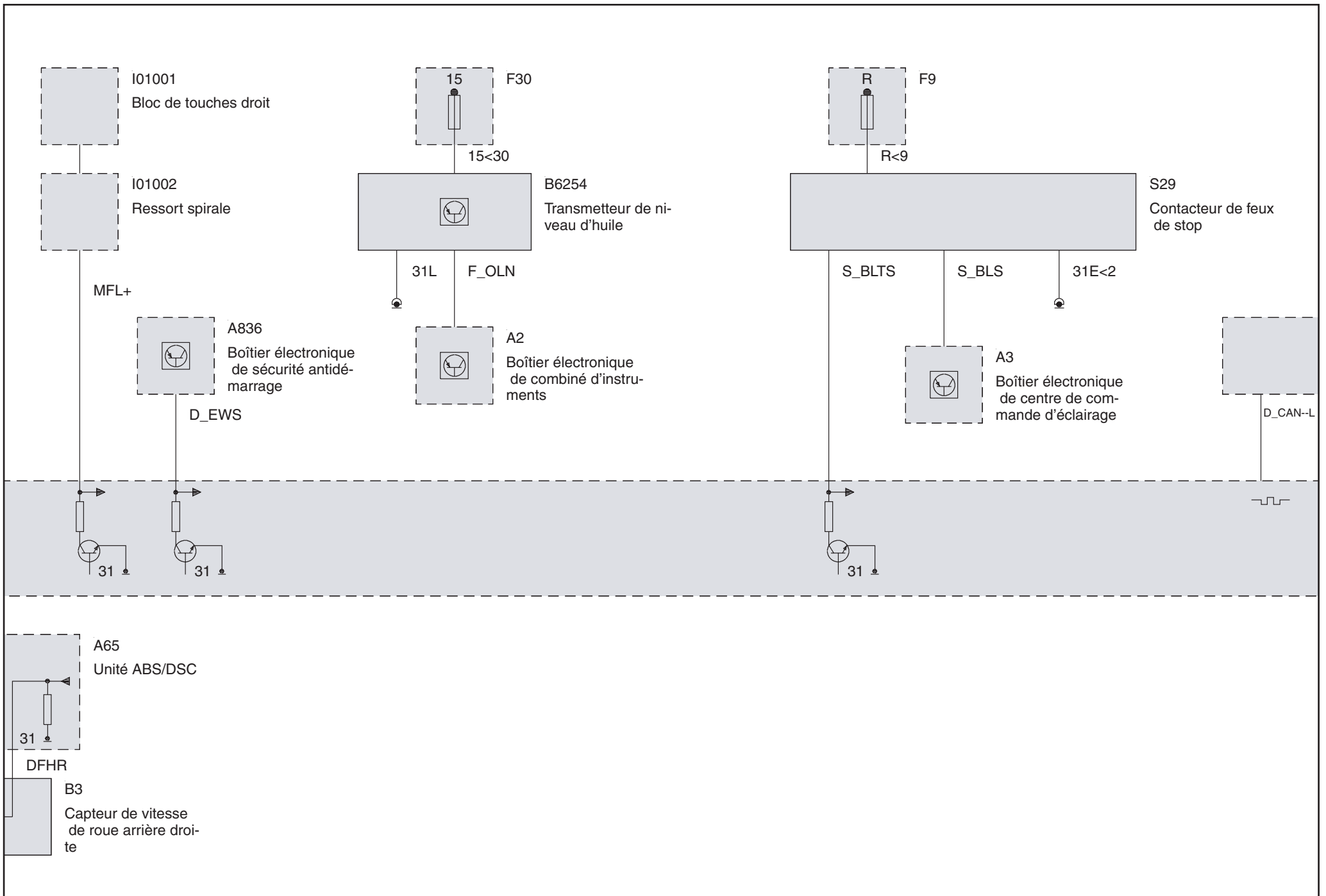

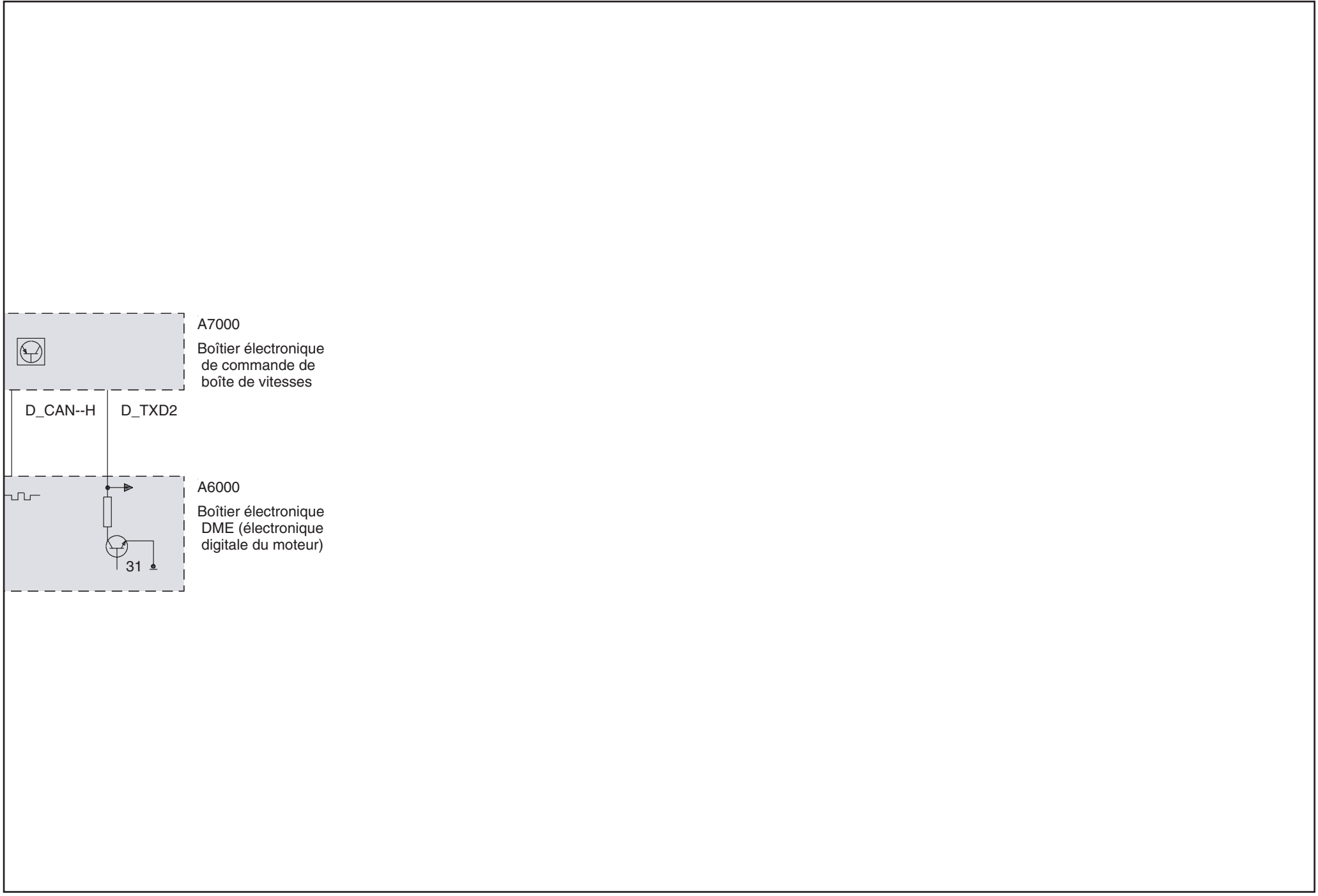

A7000  
Boîtier électronique  
de commande de  
boîte de vitesses

D\_CAN--H    D\_TXD2

A6000  
Boîtier électronique  
DME (électronique  
digitale du moteur)

31

Commande du moteur, signaux/signaux auxiliaires (sans Boîte automatique)

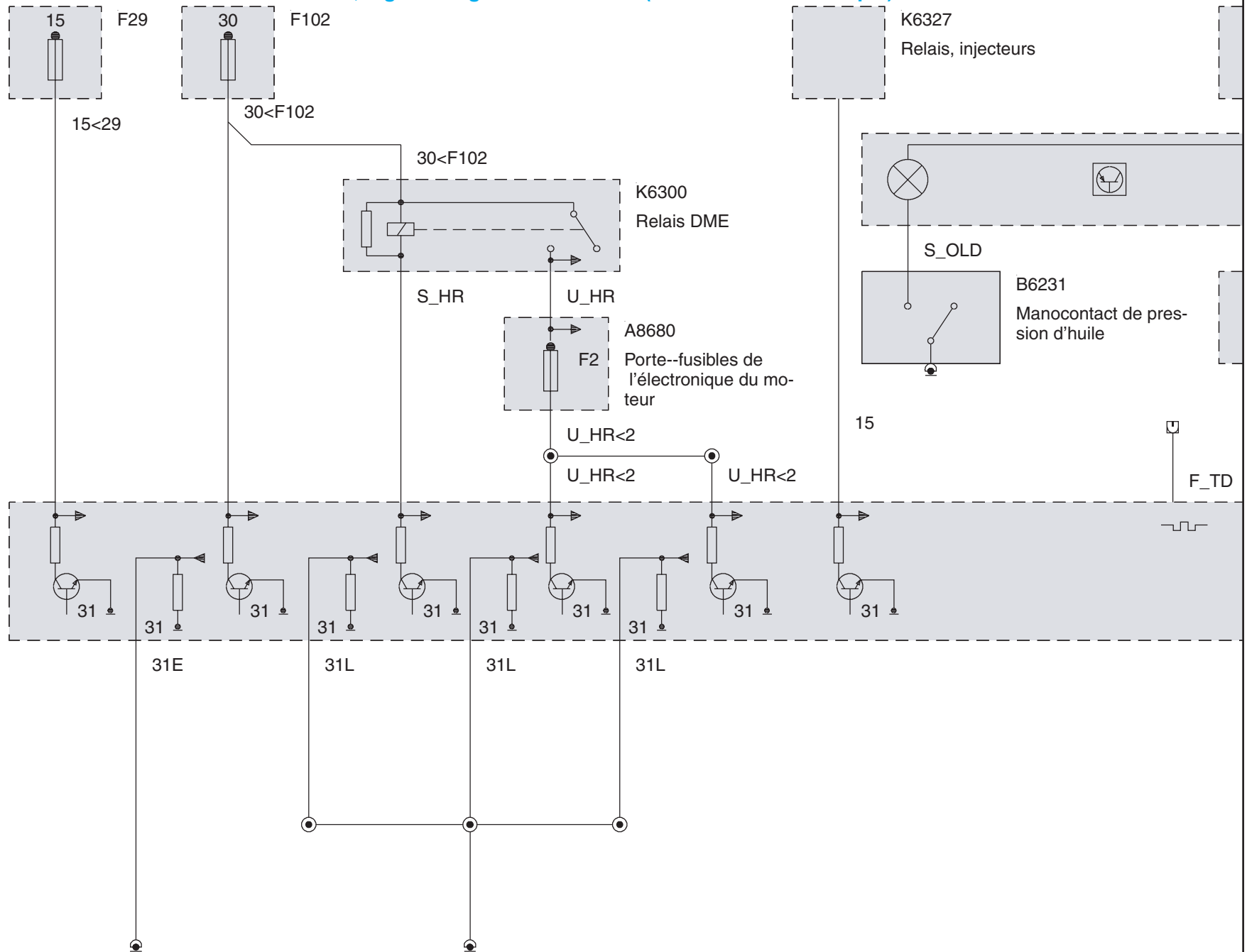

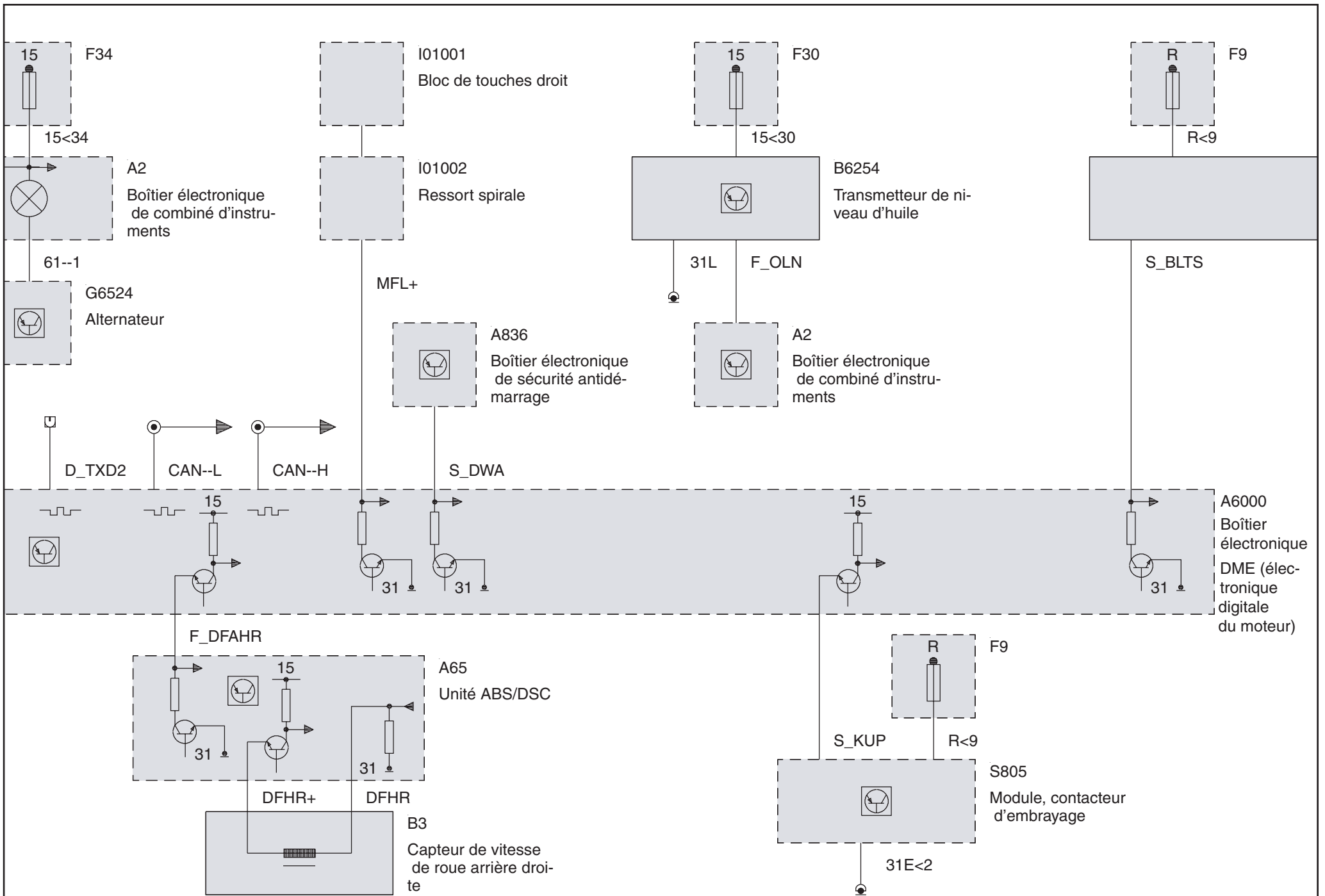

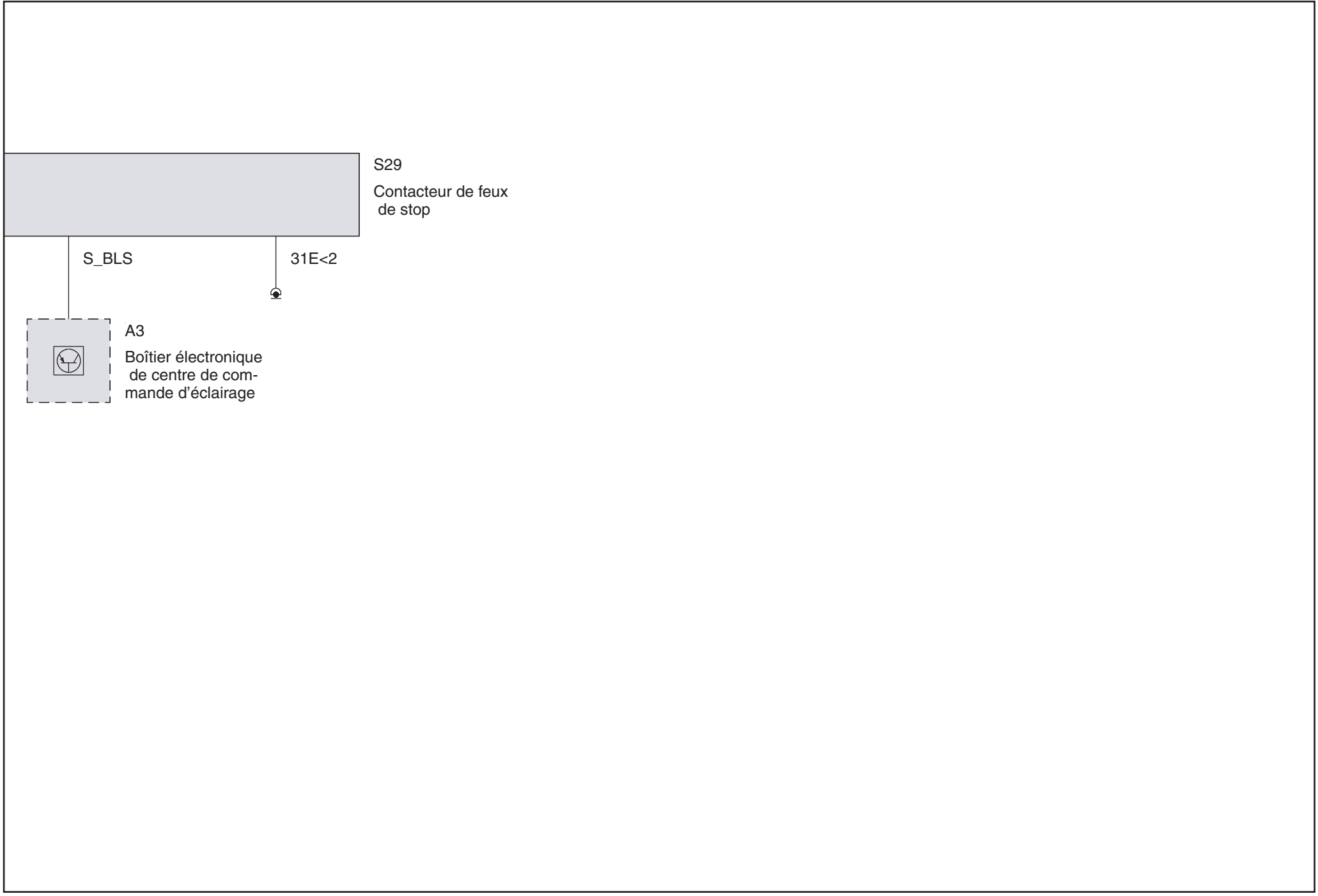

## Clapet d'échappement ( 330i\_M54)

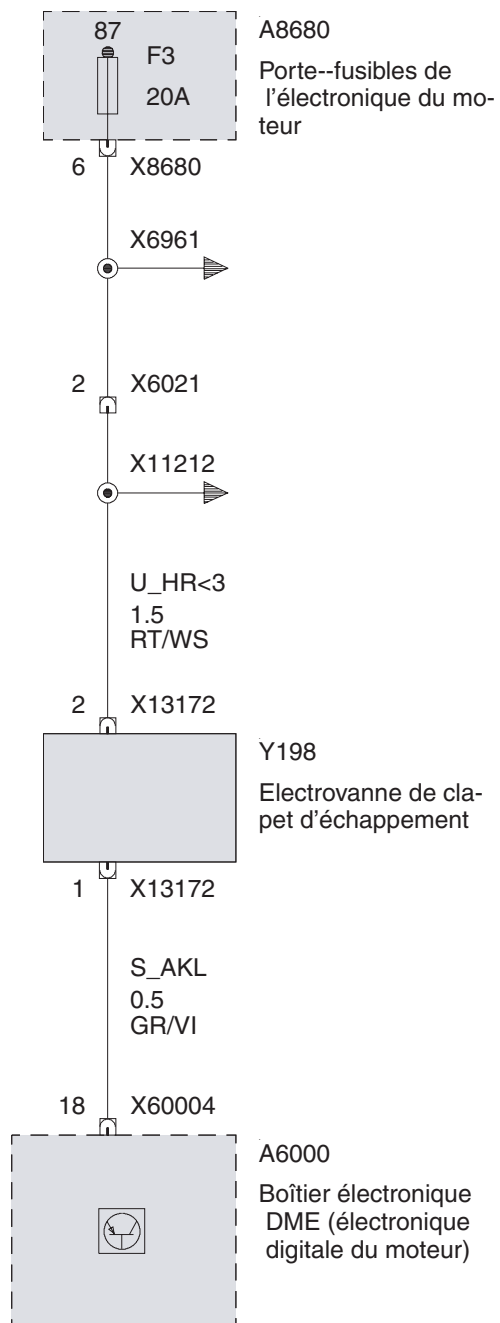

Injecteurs

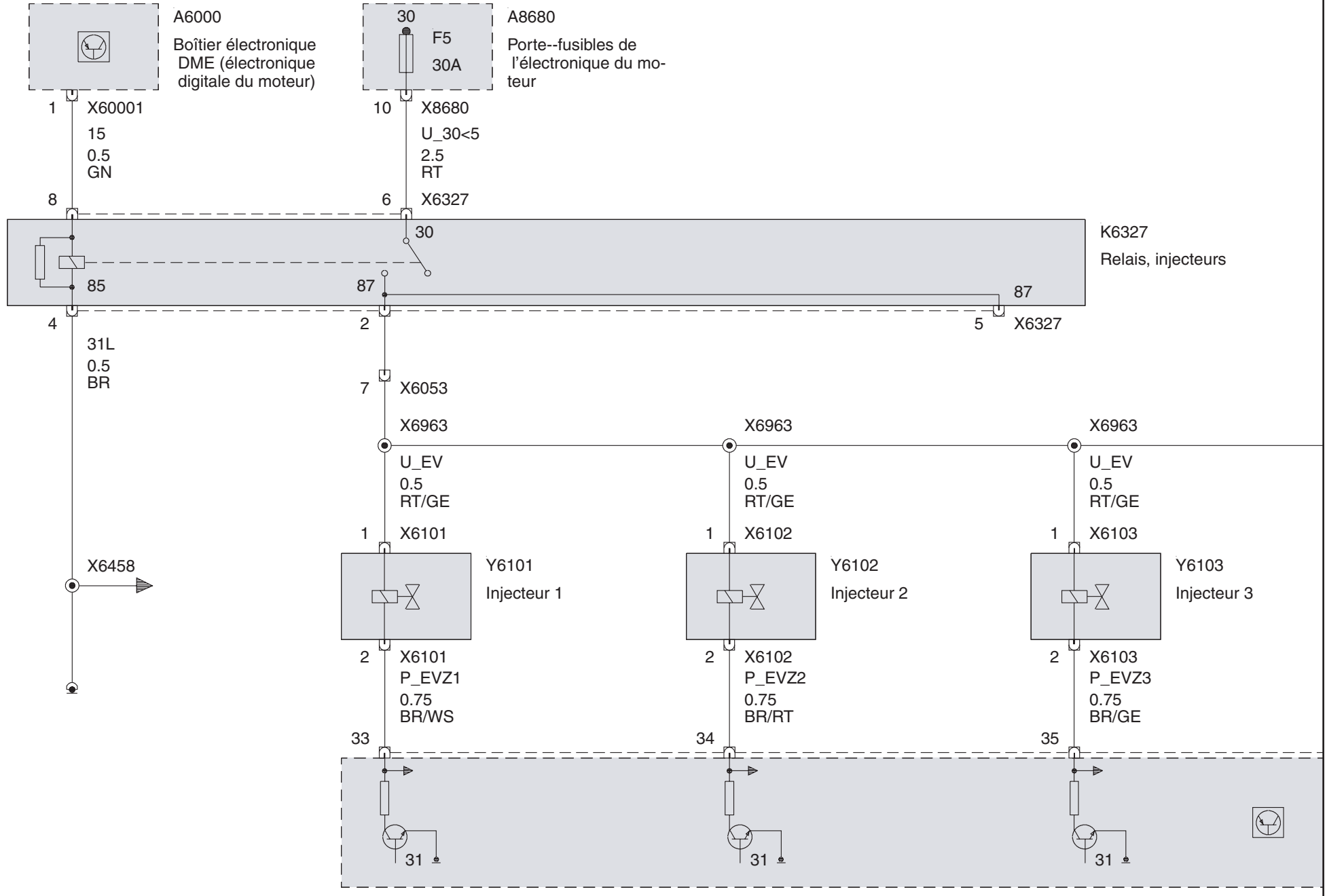

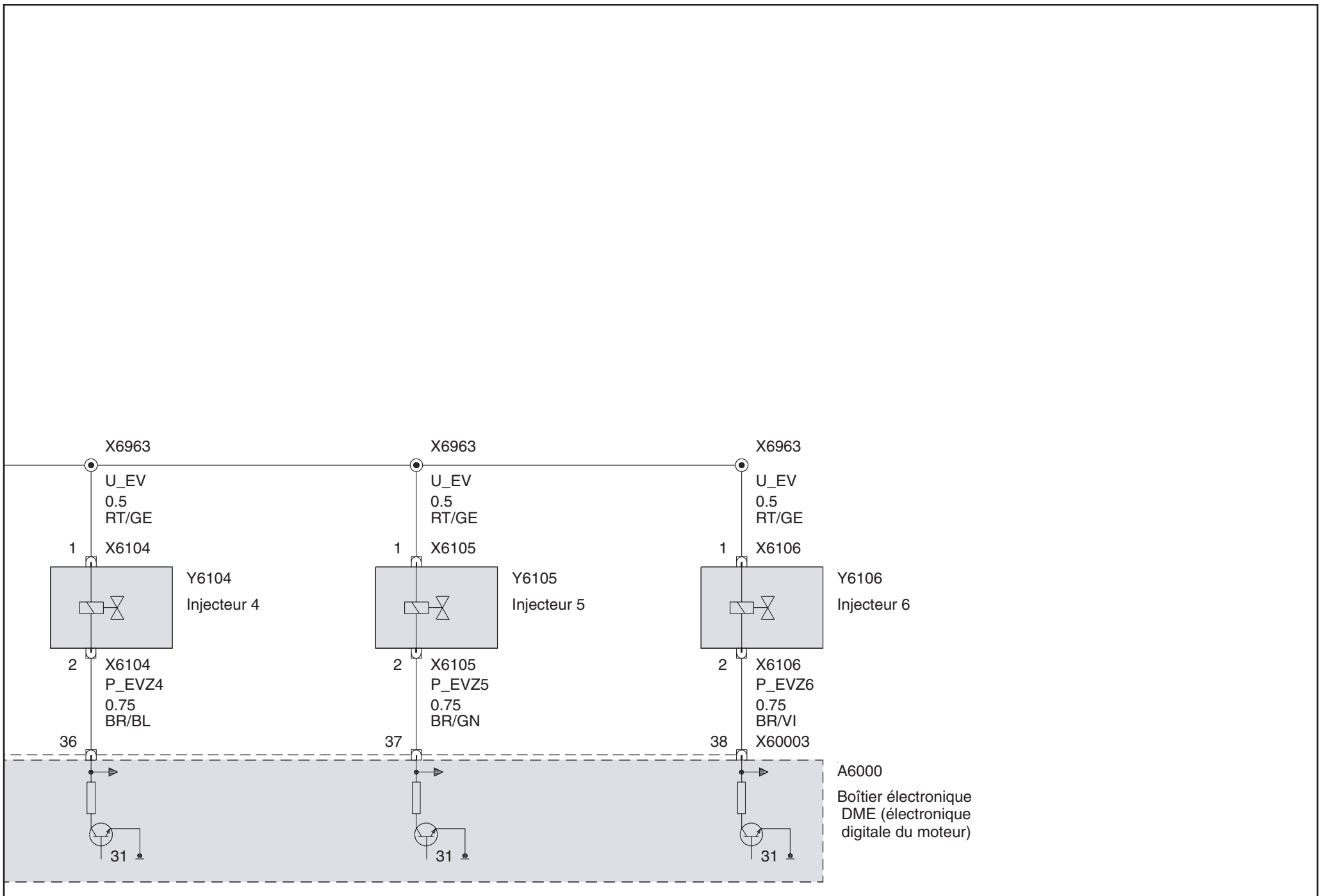



Pompe à carburant

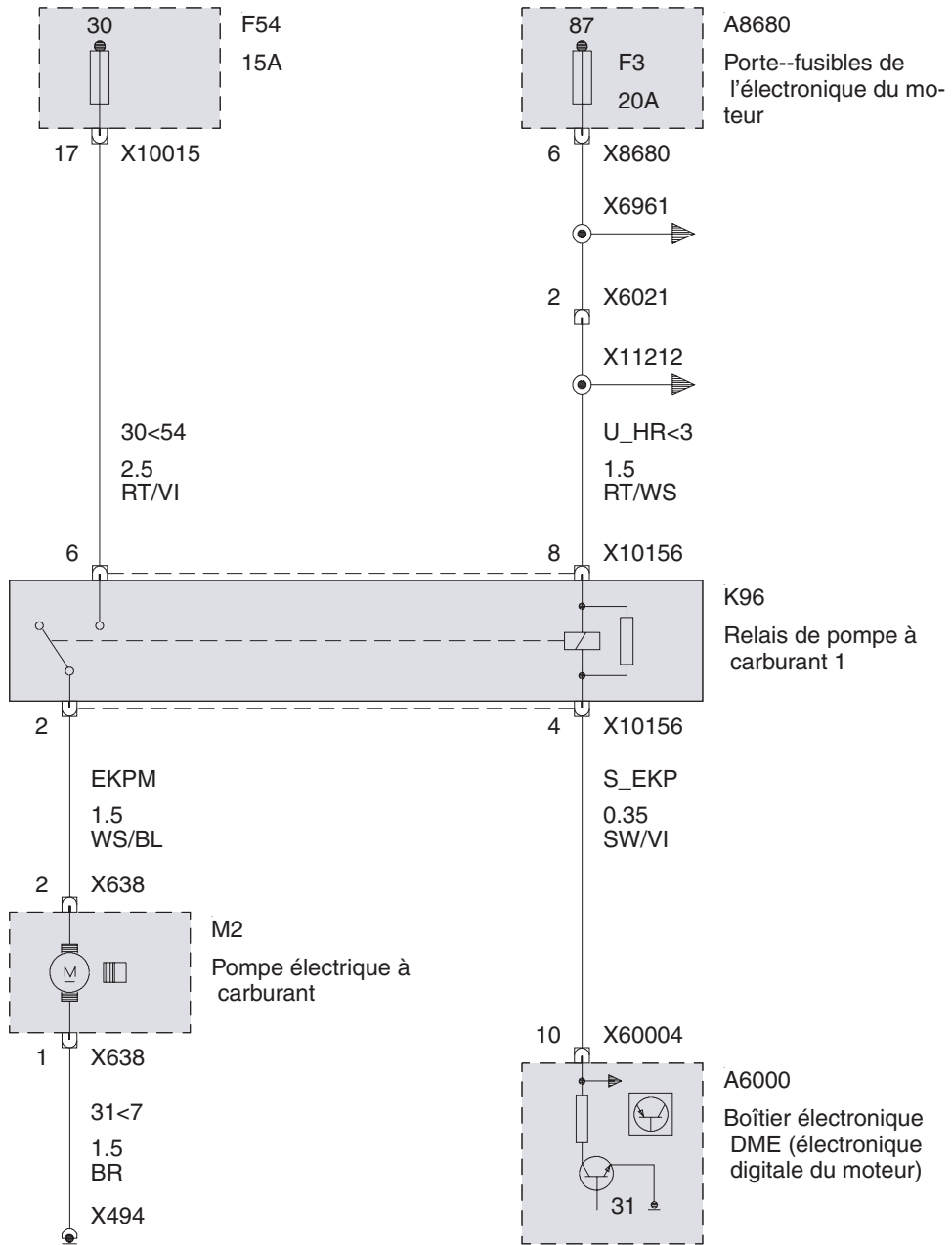

**Bobines d'allumage**

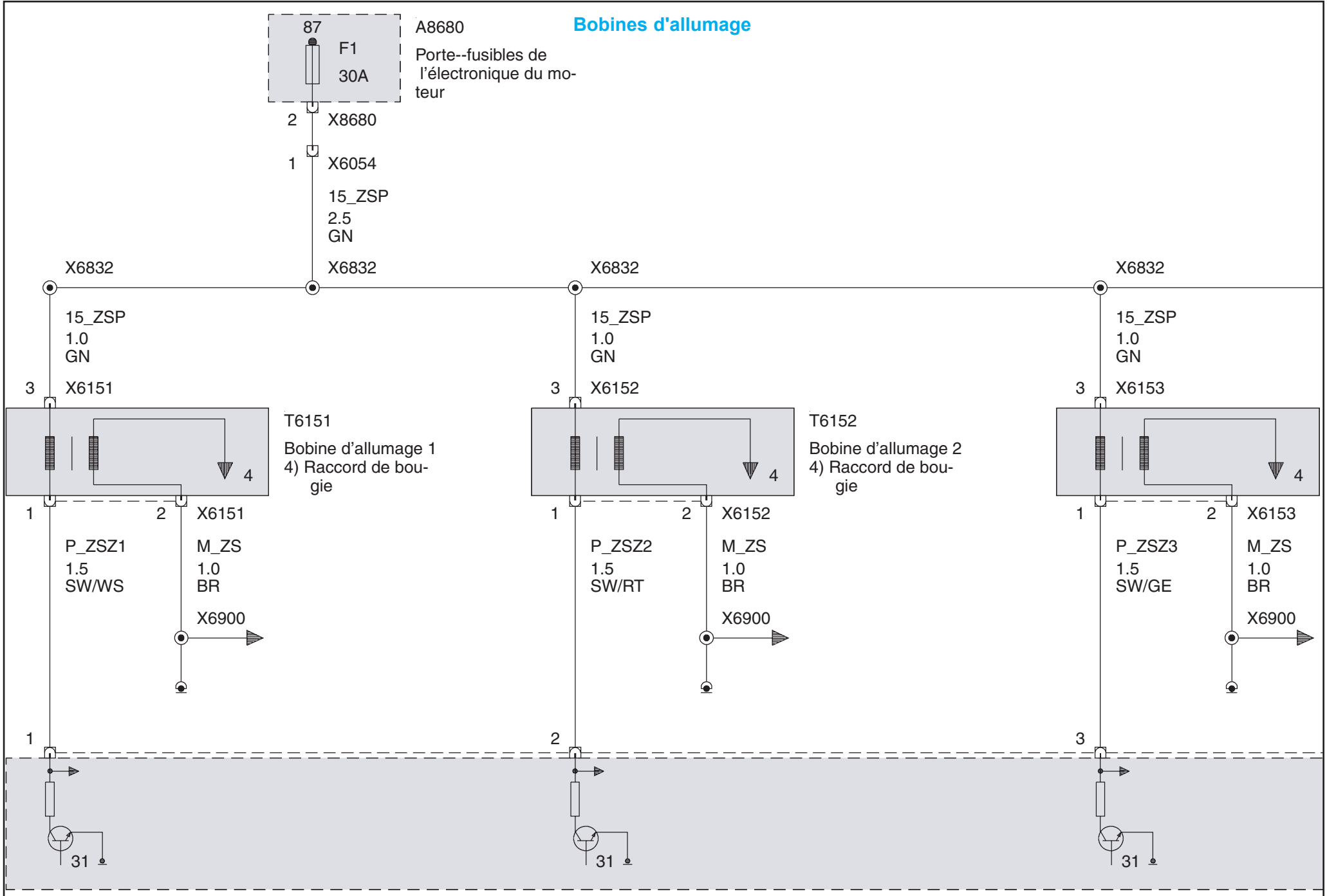

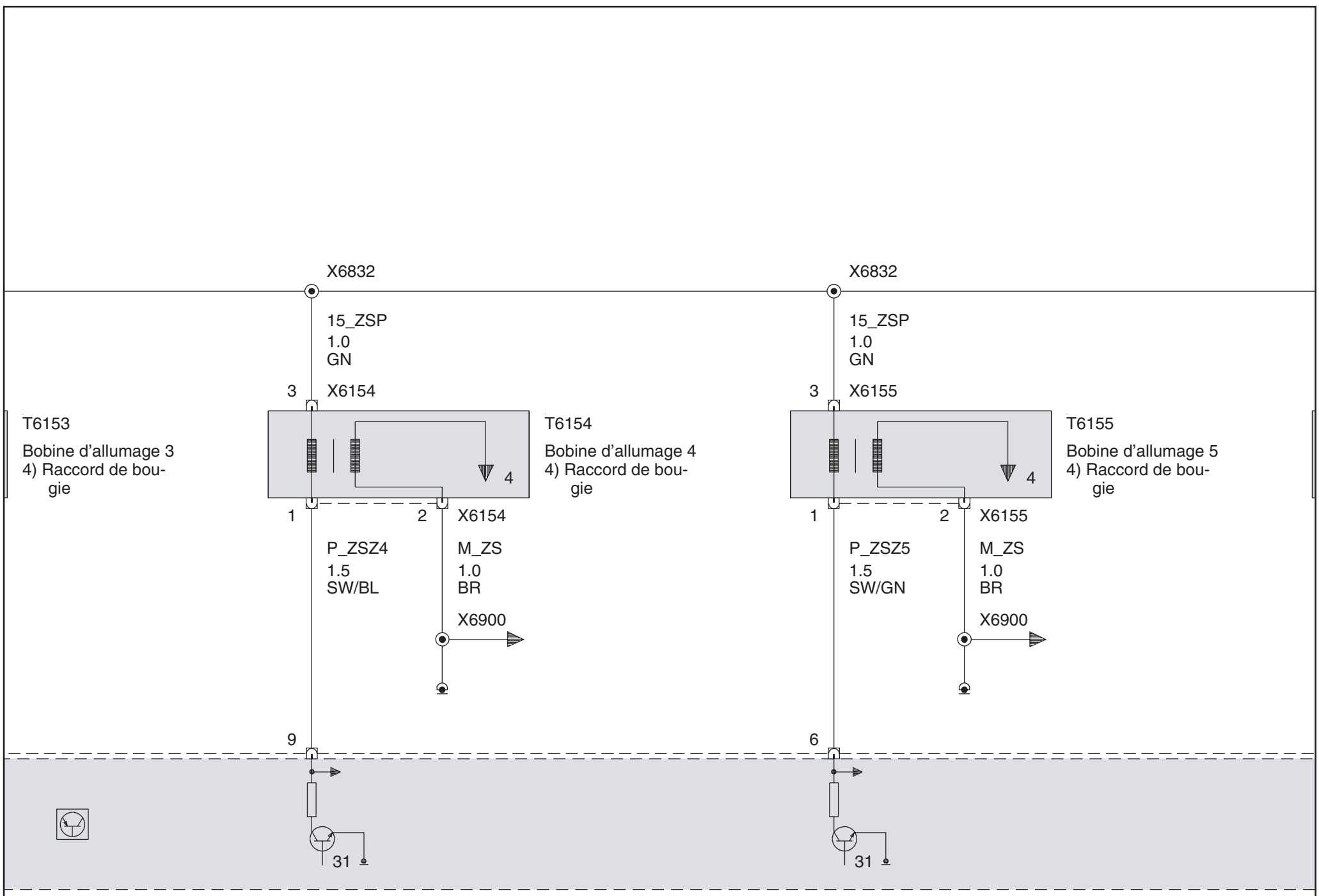

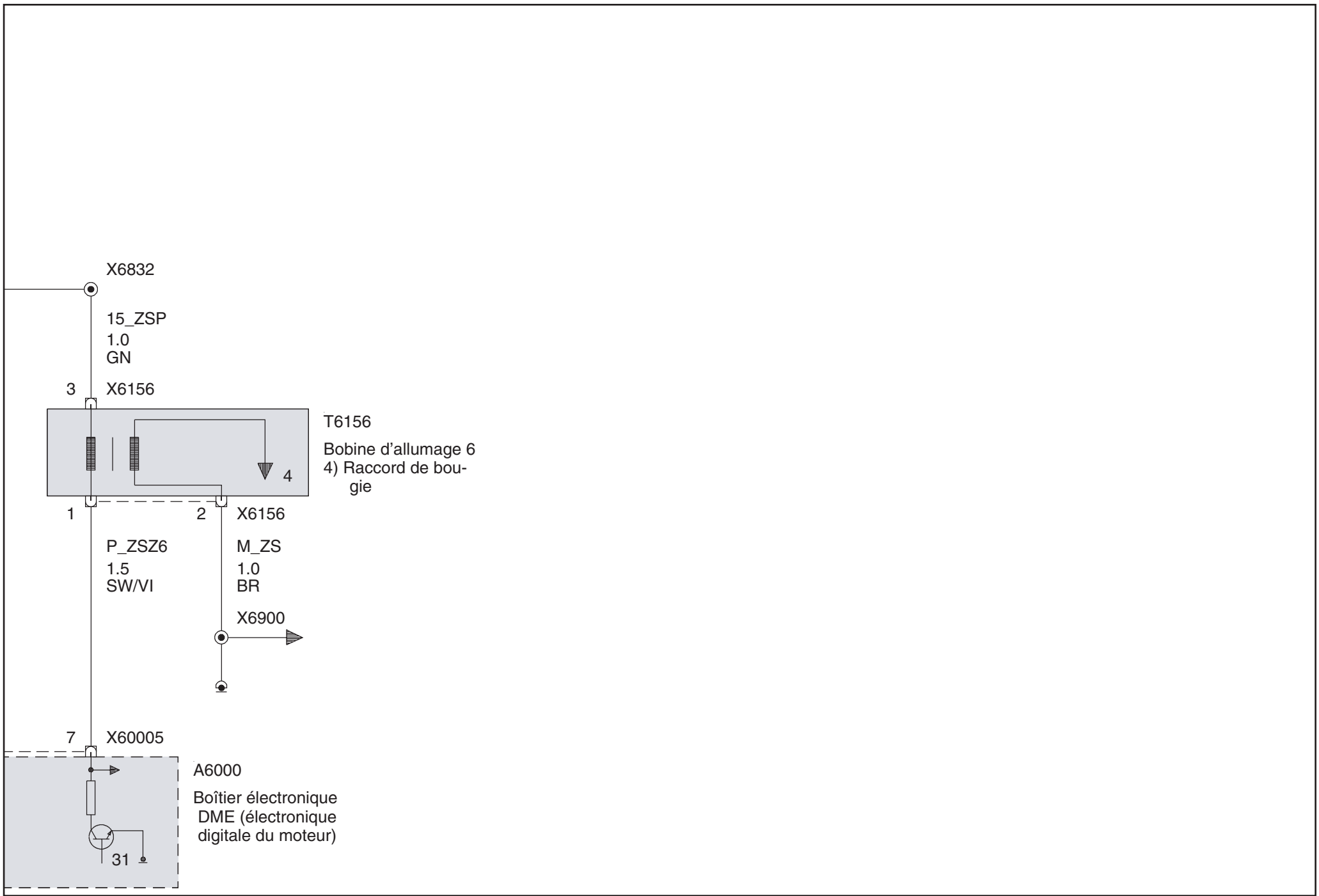

Détecteur de cliquetis double

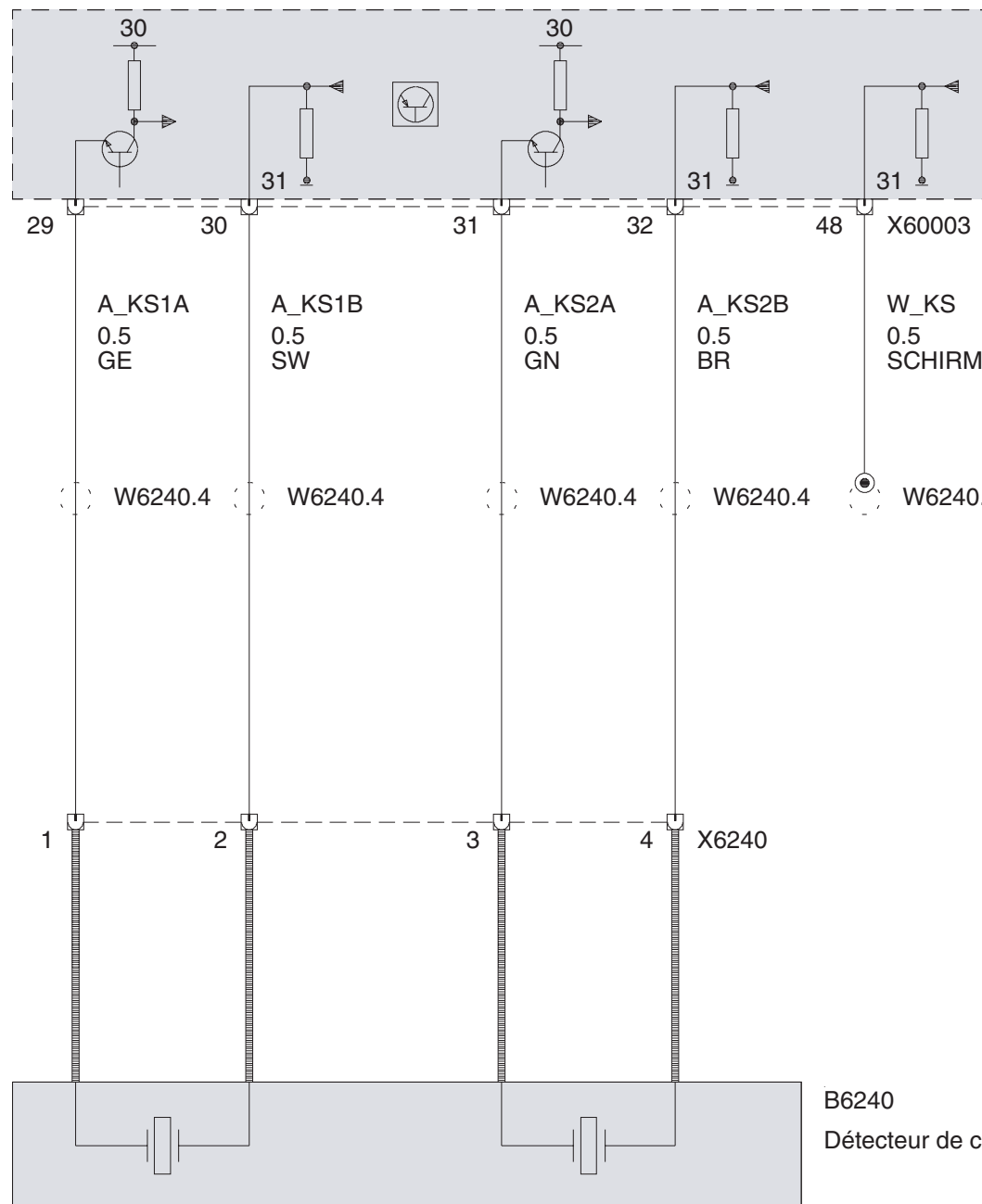

A6000

Boîtier électronique  
DME (électronique  
digitale du moteur)

Sondes lambda avant catalyseur

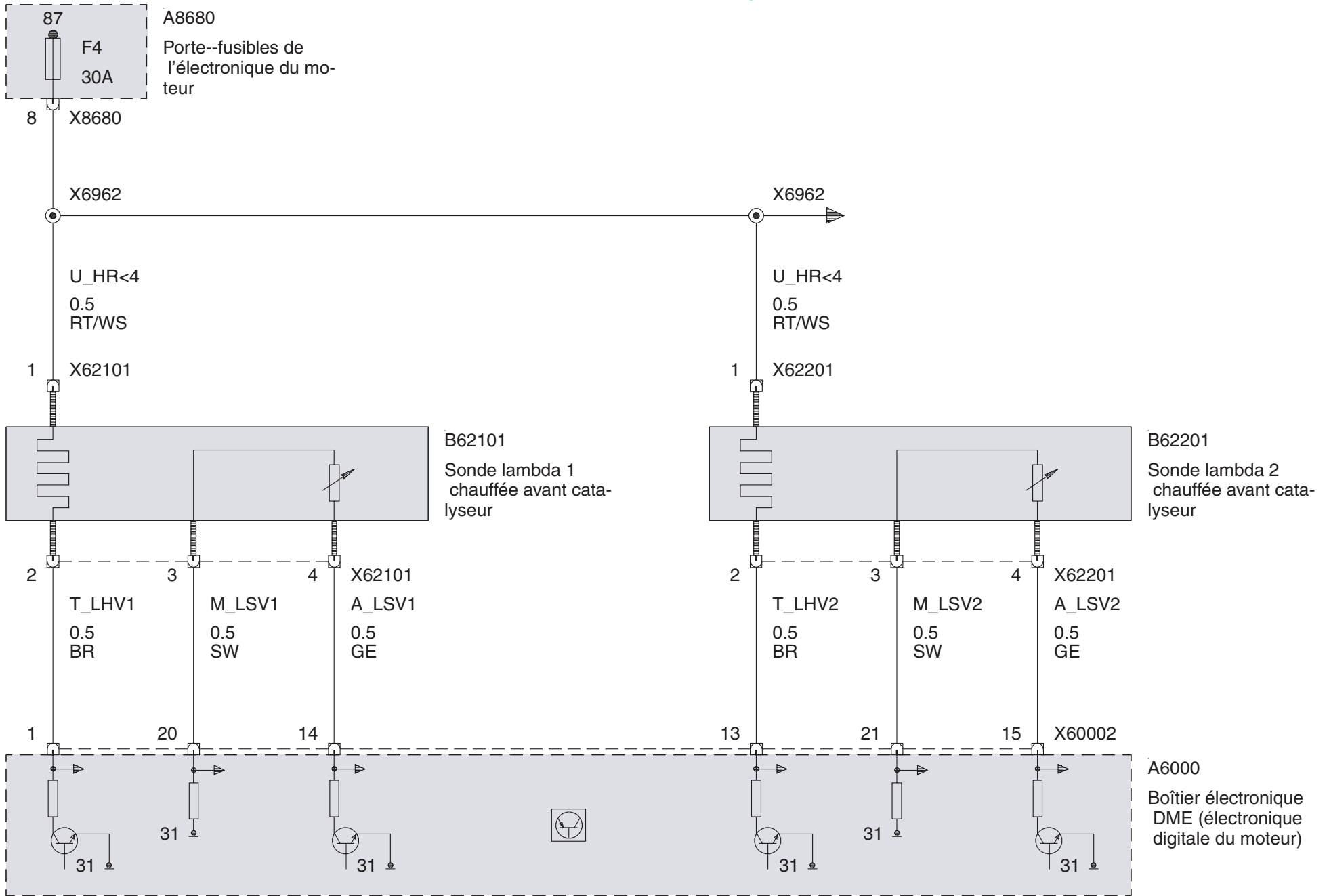

Sondes lambda après catalyseur

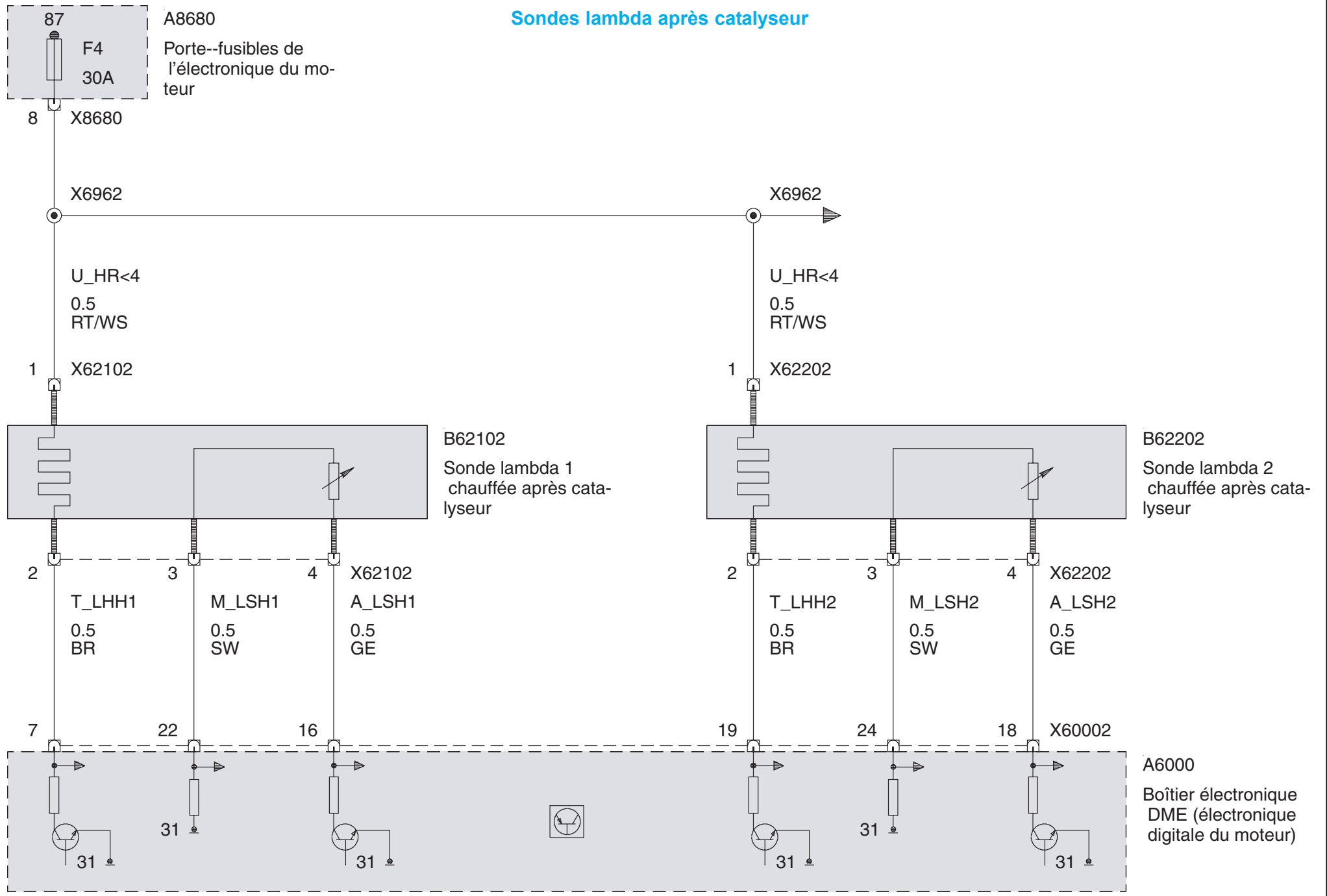

Papillon électrique (EDK)

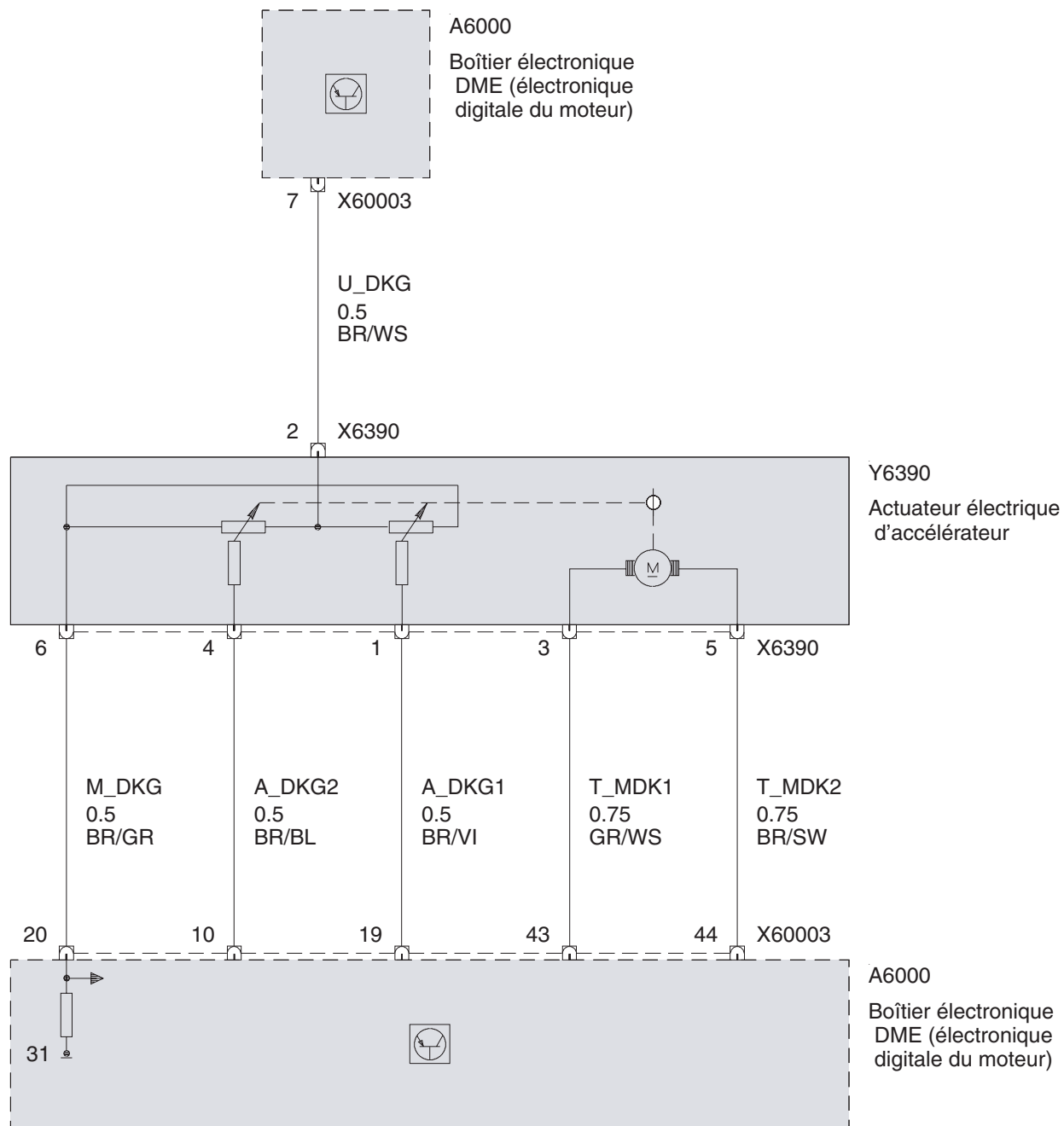



Electrovanne tubulure d'admission (système d'admission différencié)

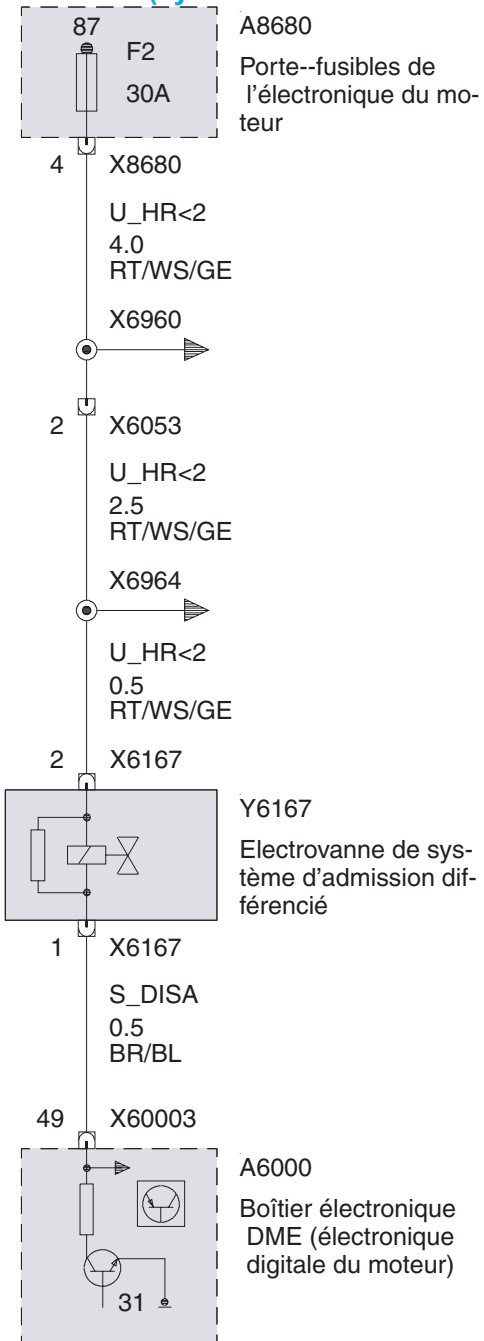

Actuateur de ralenti

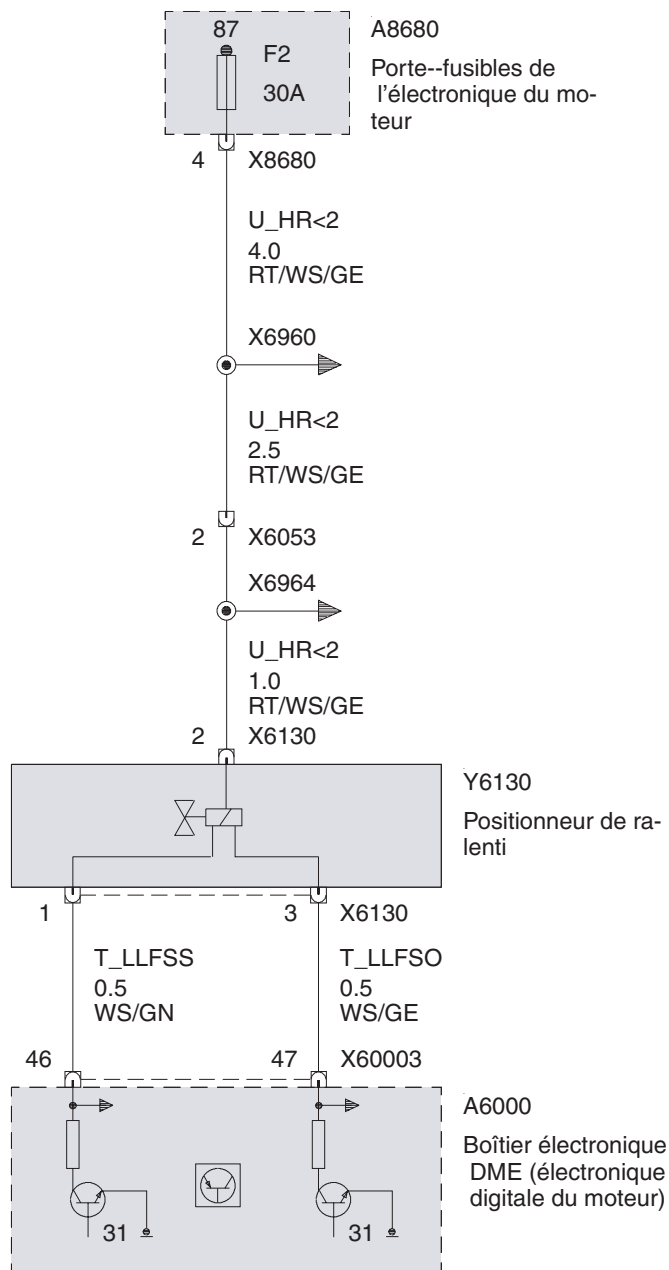

Débitmètre massique à film chaud

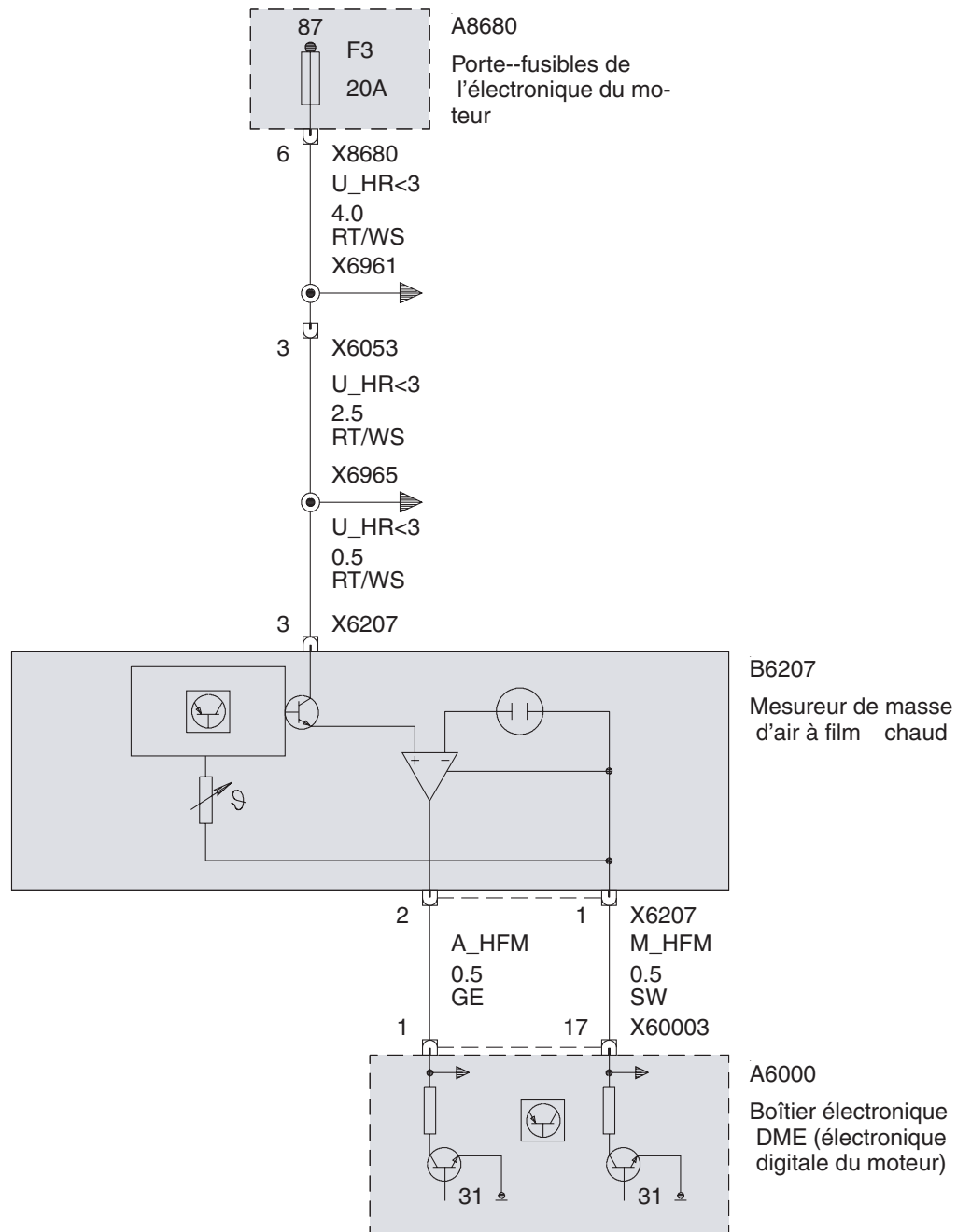

## Sonde de température d'air aspiré

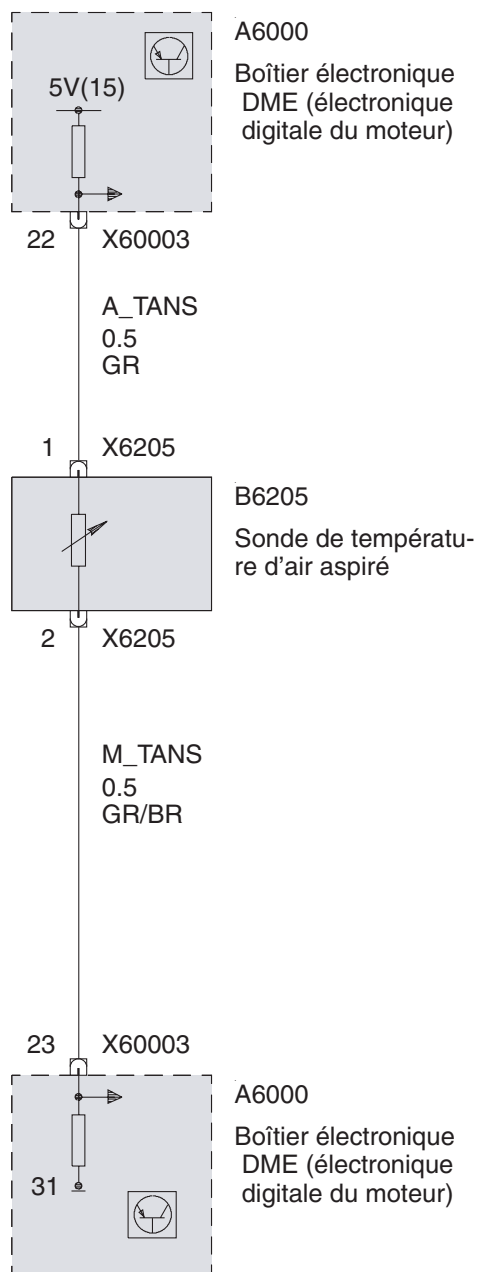

Capteur de vilebrequin

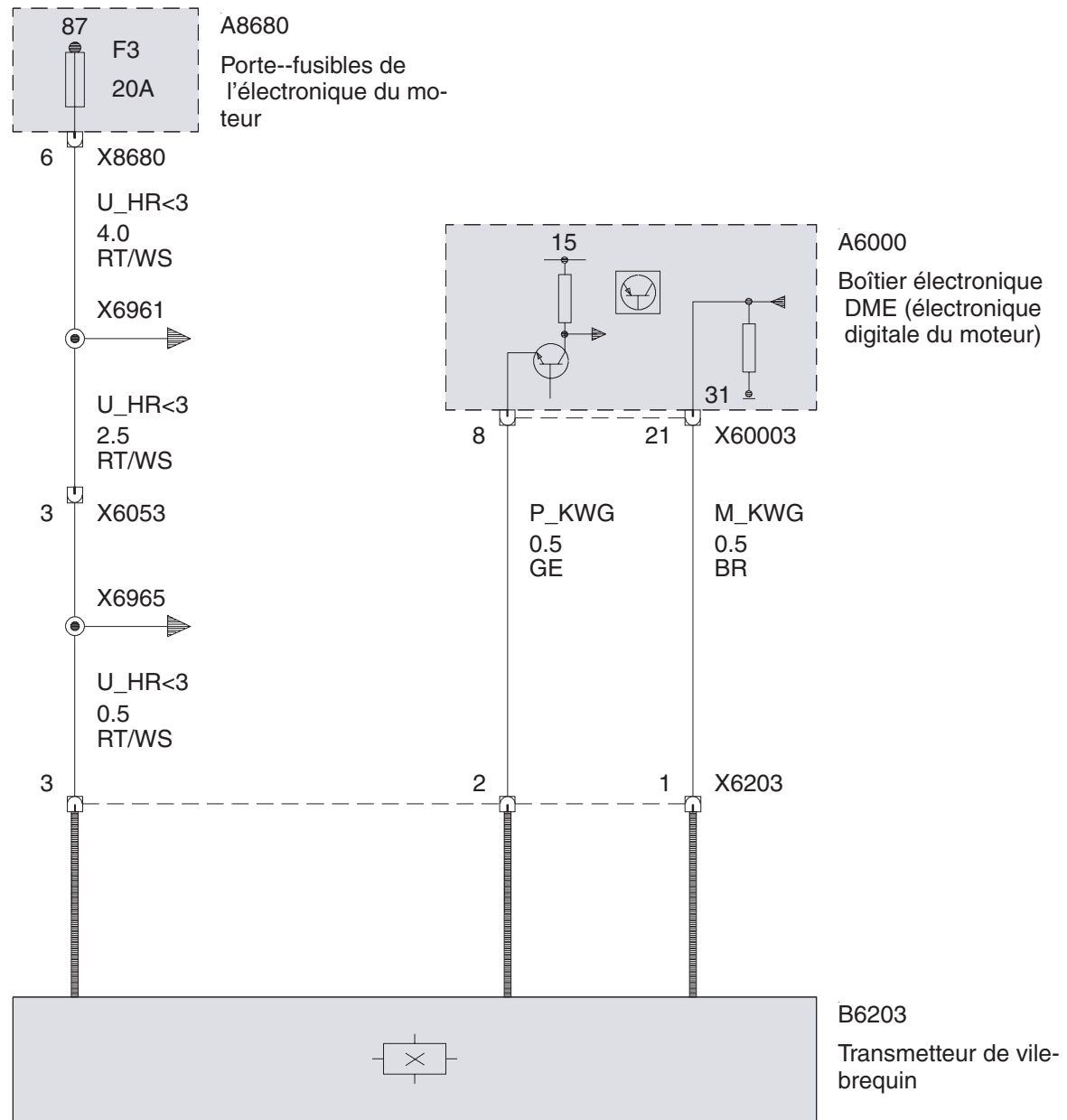

Refroidissement du moteur

Thermostat

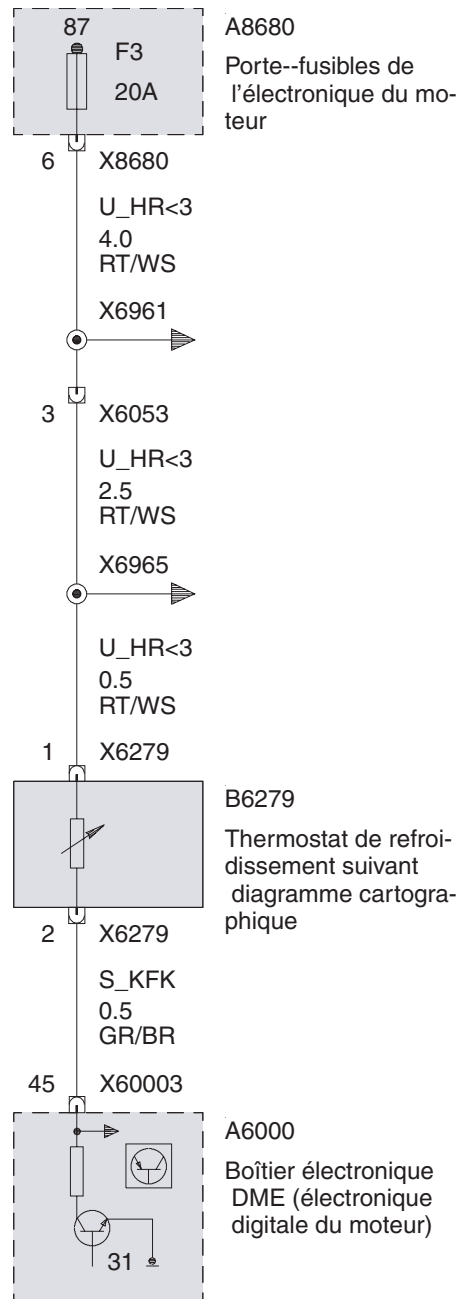

Sonde de température de liquide de refroidissement du moteur

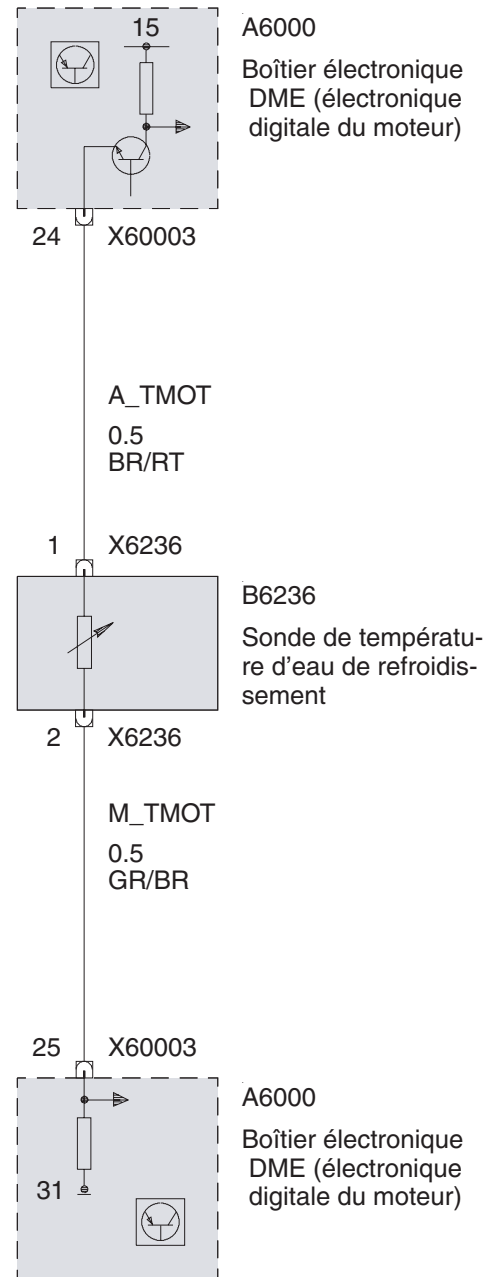

Température de liquide de refroidissement/ventilateur électrique (jusque 2003\_03)

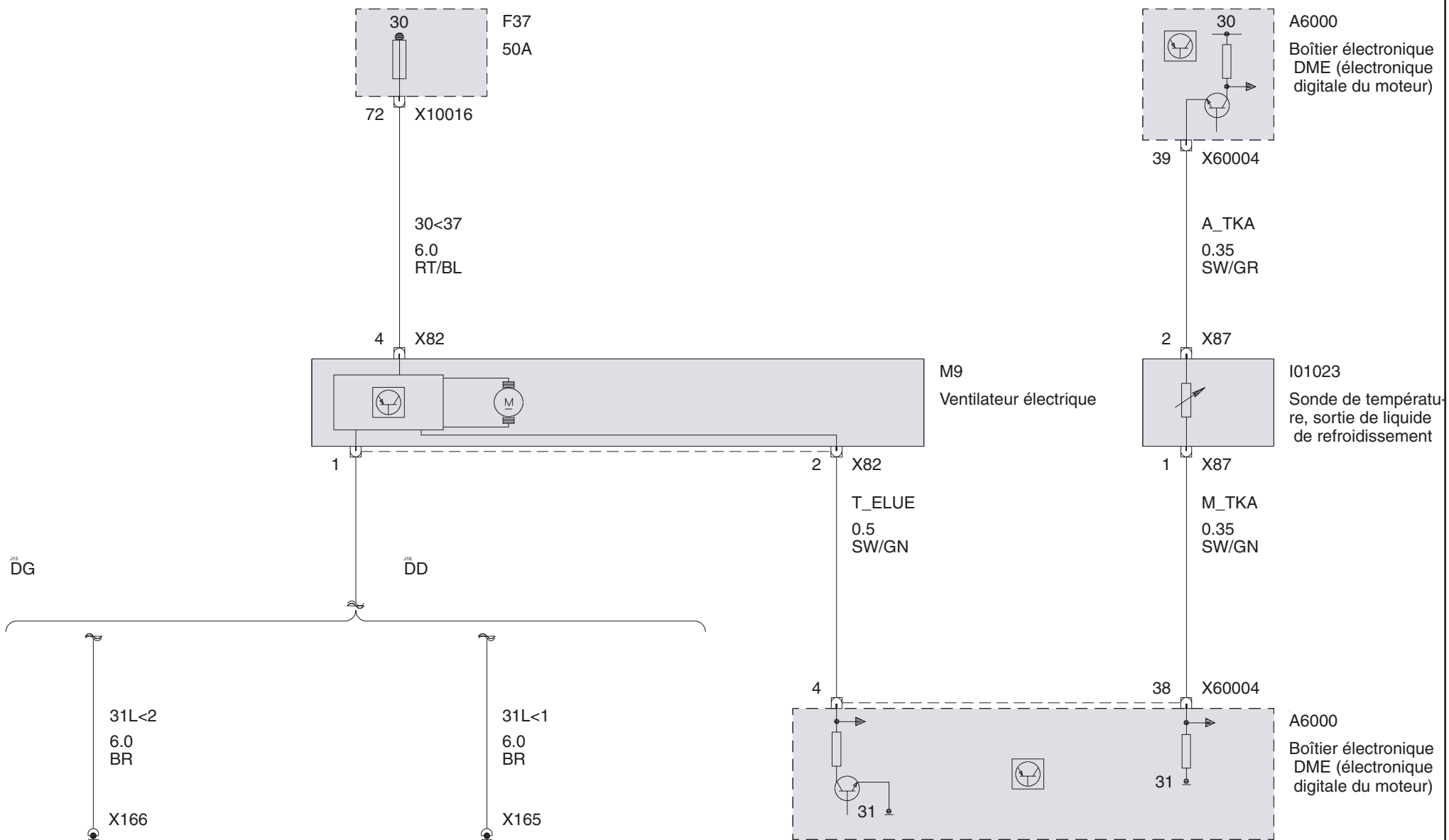



Température de liquide de refroidissement/ventilateur électrique (( Berline ou Compact ou Touring ) à partir de 2003\_03)

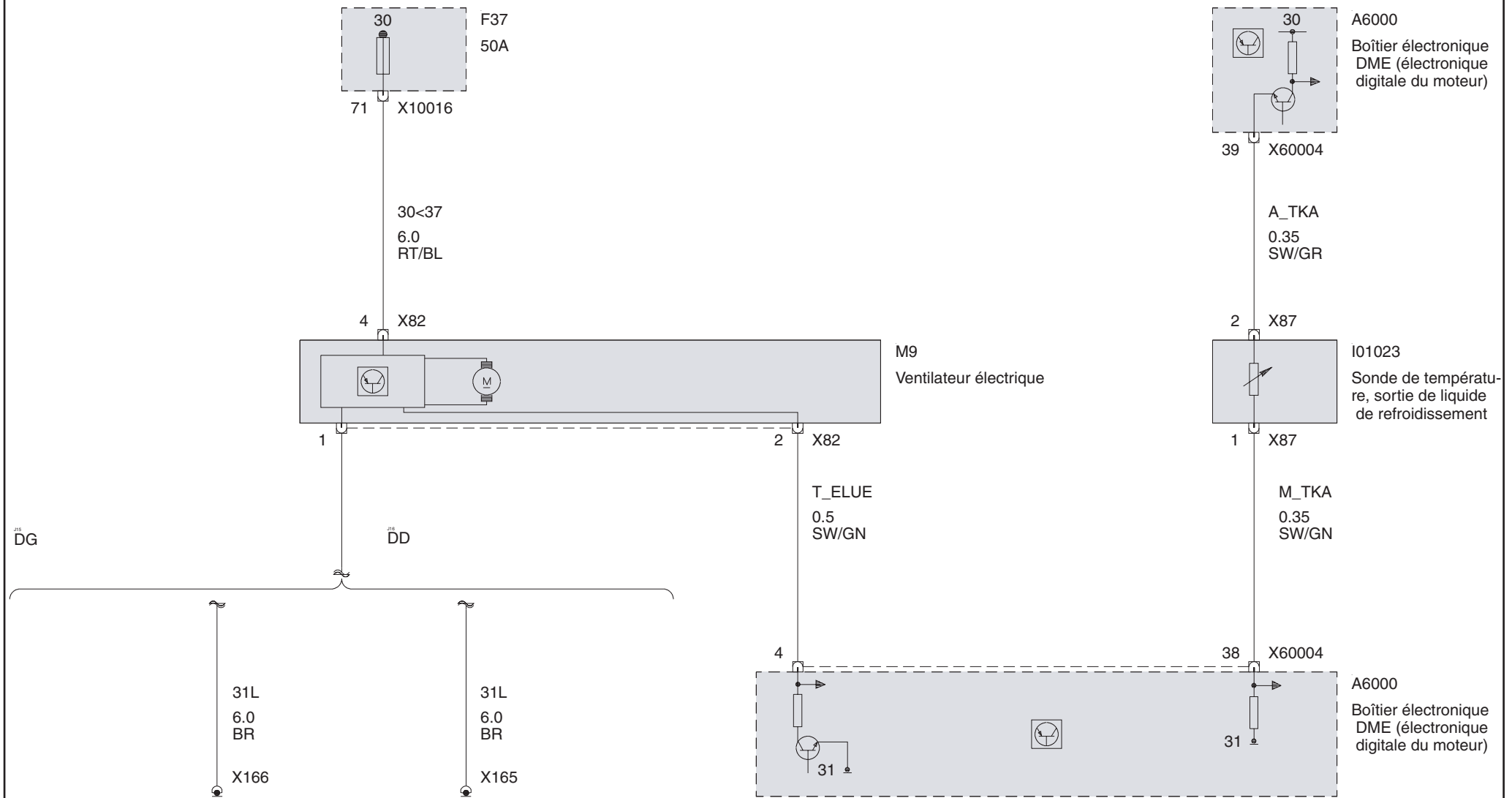

Température de liquide de refroidissement/ventilateur électrique (( Coupé ou Cabriolet ) à partir de 2003\_03)

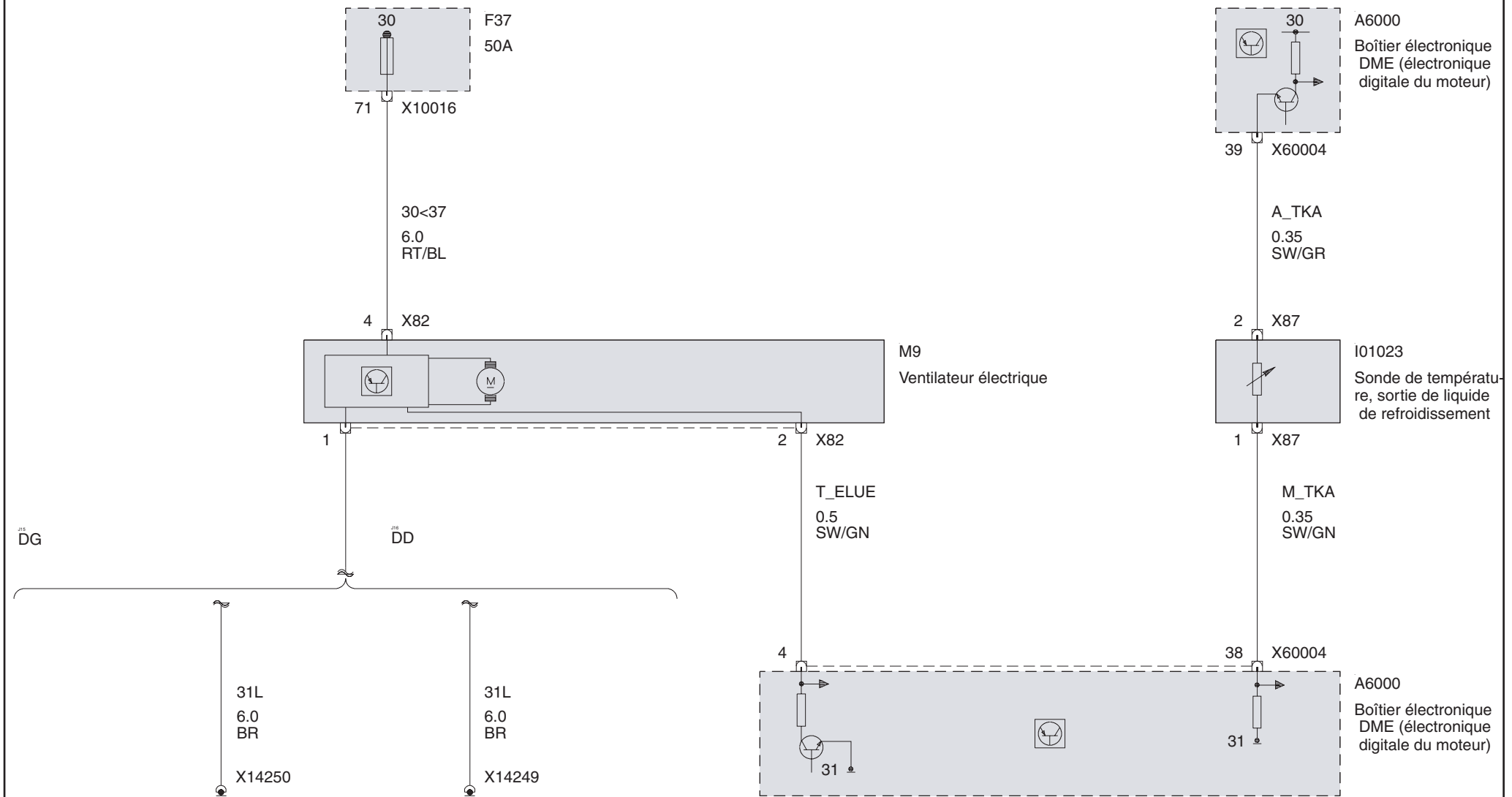

## Sonde de température d'huile du moteur

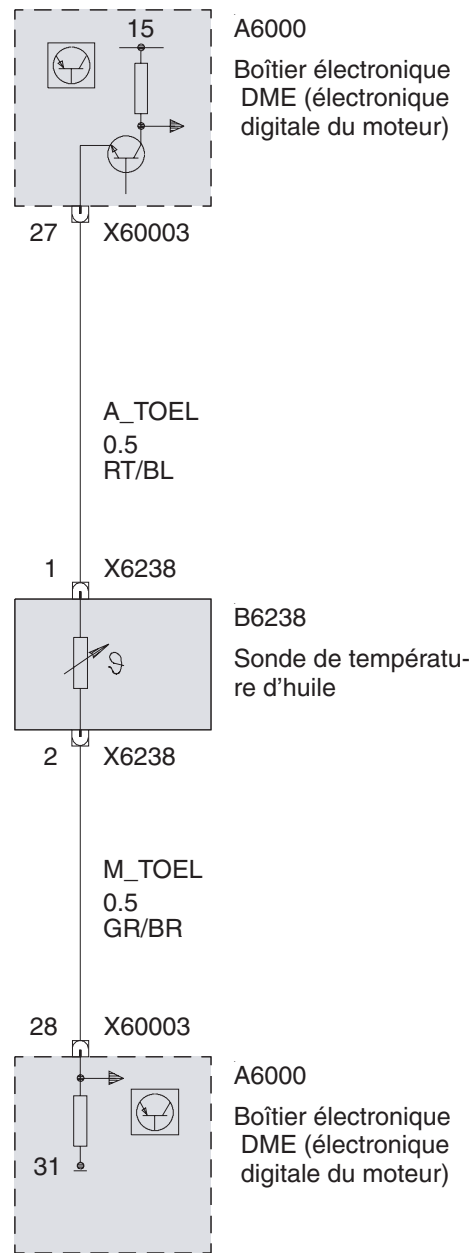

**Arbre à cames**  
 Capteur d'arbre à cames

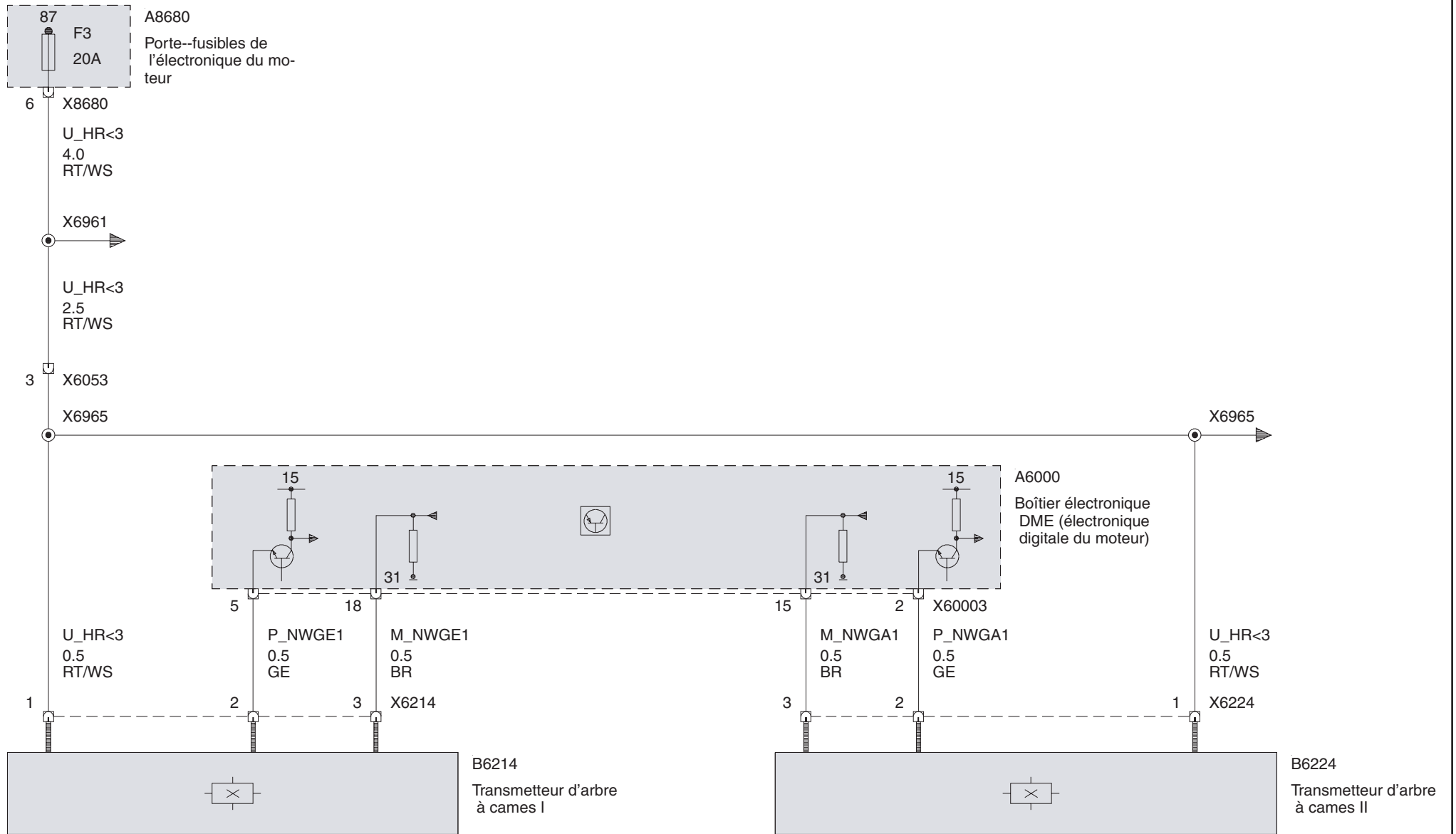

Electrovannes VANOS

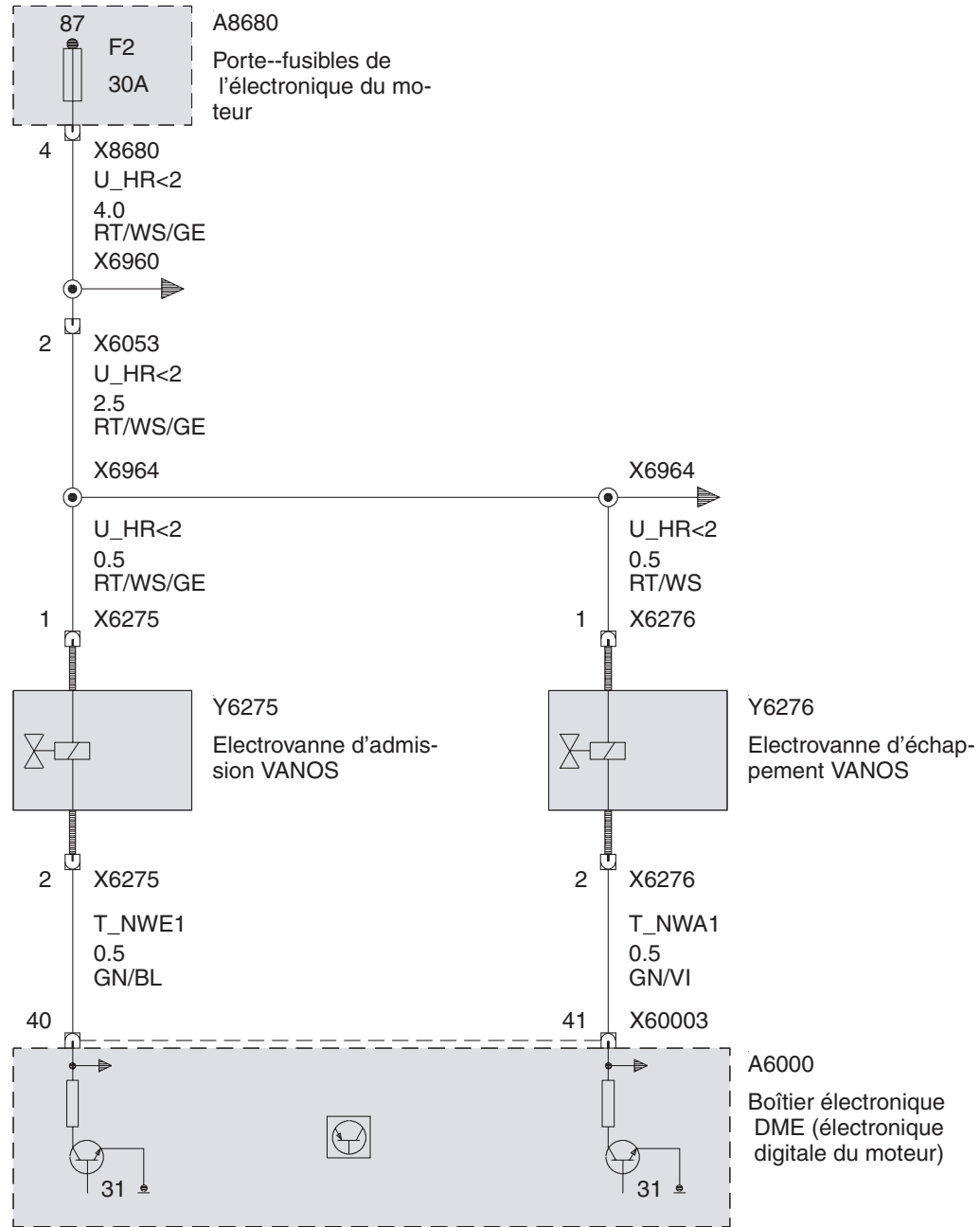

Signal de vitesse

Signal de vitesse (DSC MK20 Contrôle dynamique de stabilité)

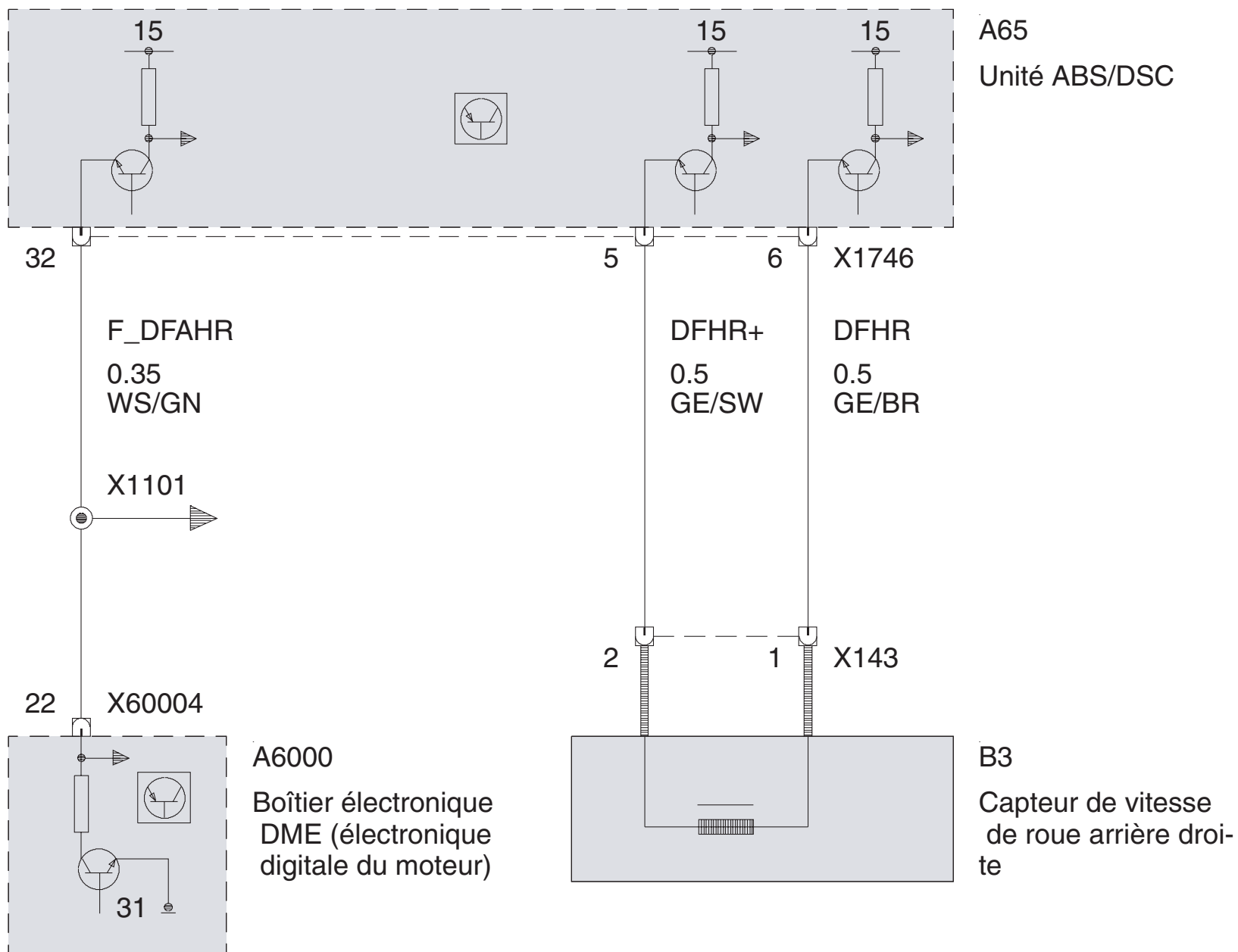

Signal de vitesse (ASC MK20 contrôle automatique de stabilité)

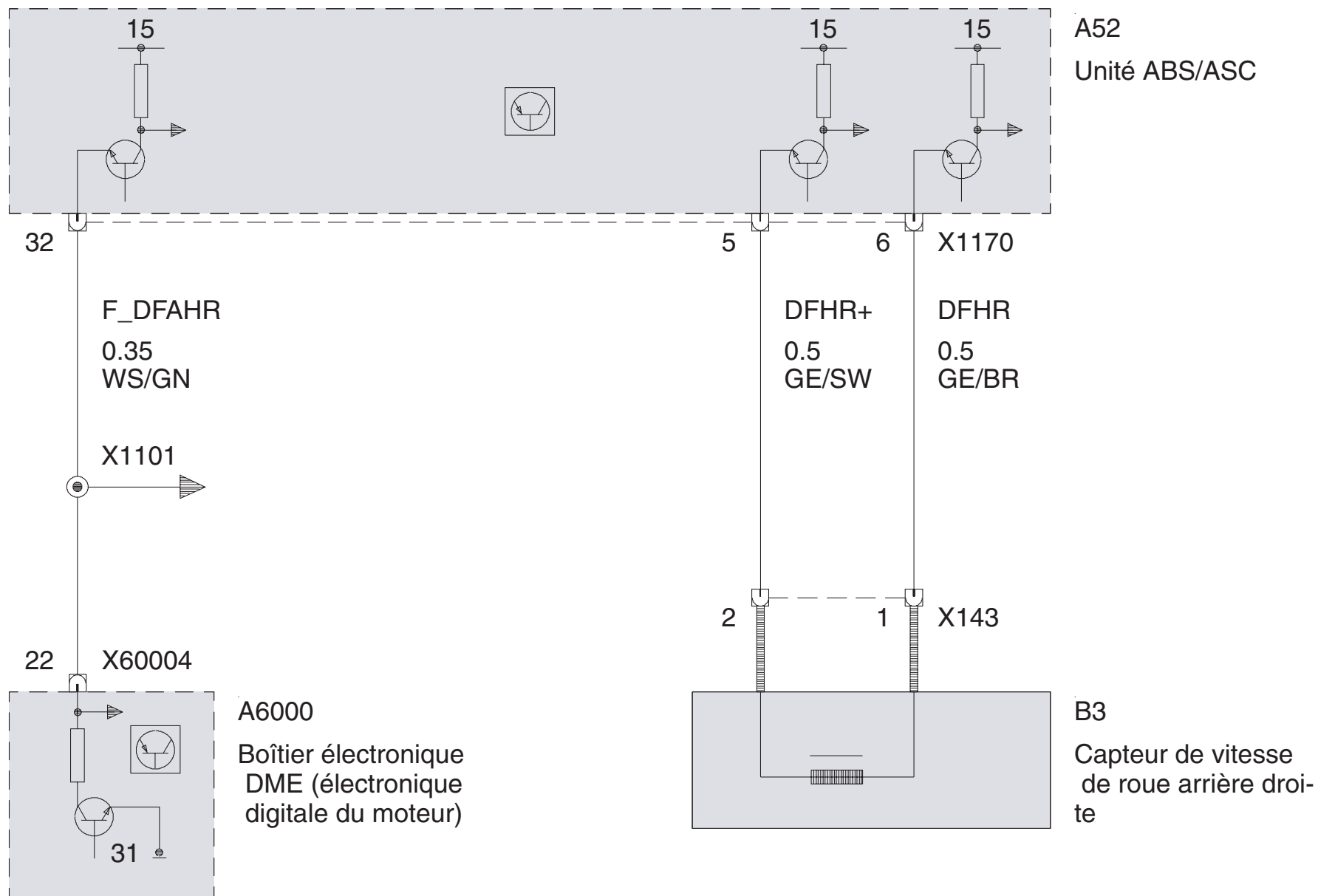

Signal de vitesse (DSC Contrôle dynamique de stabilité MK60)

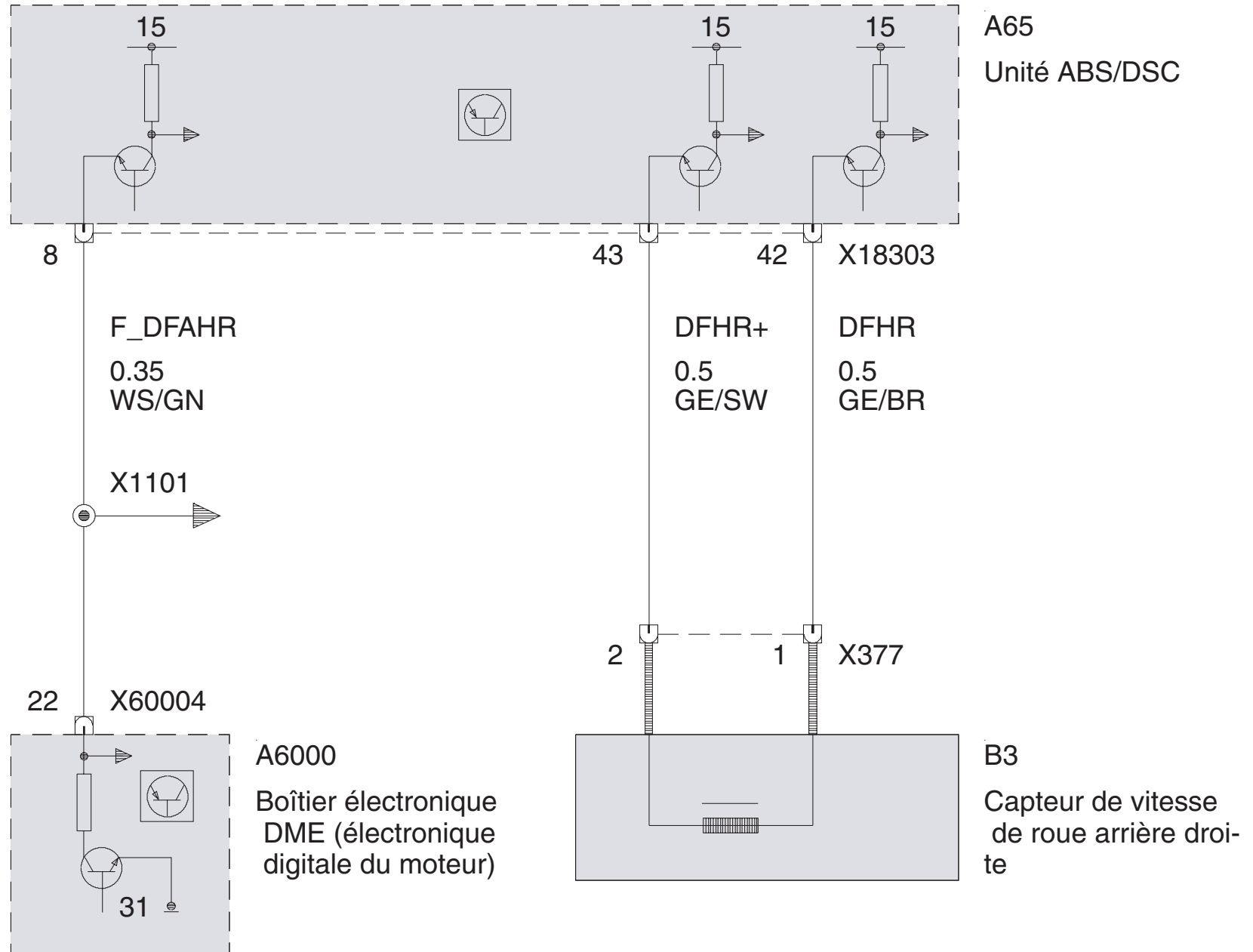



## Signal traité de vitesse de roue arrière droite (ASC MK60)

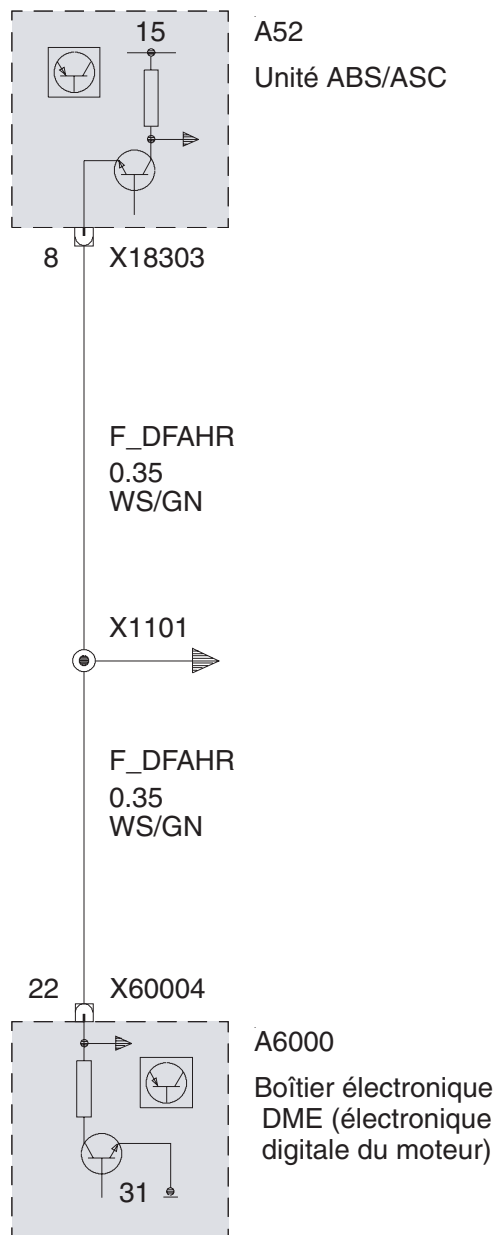

## Blocage antidémarrage électronique (EWS)

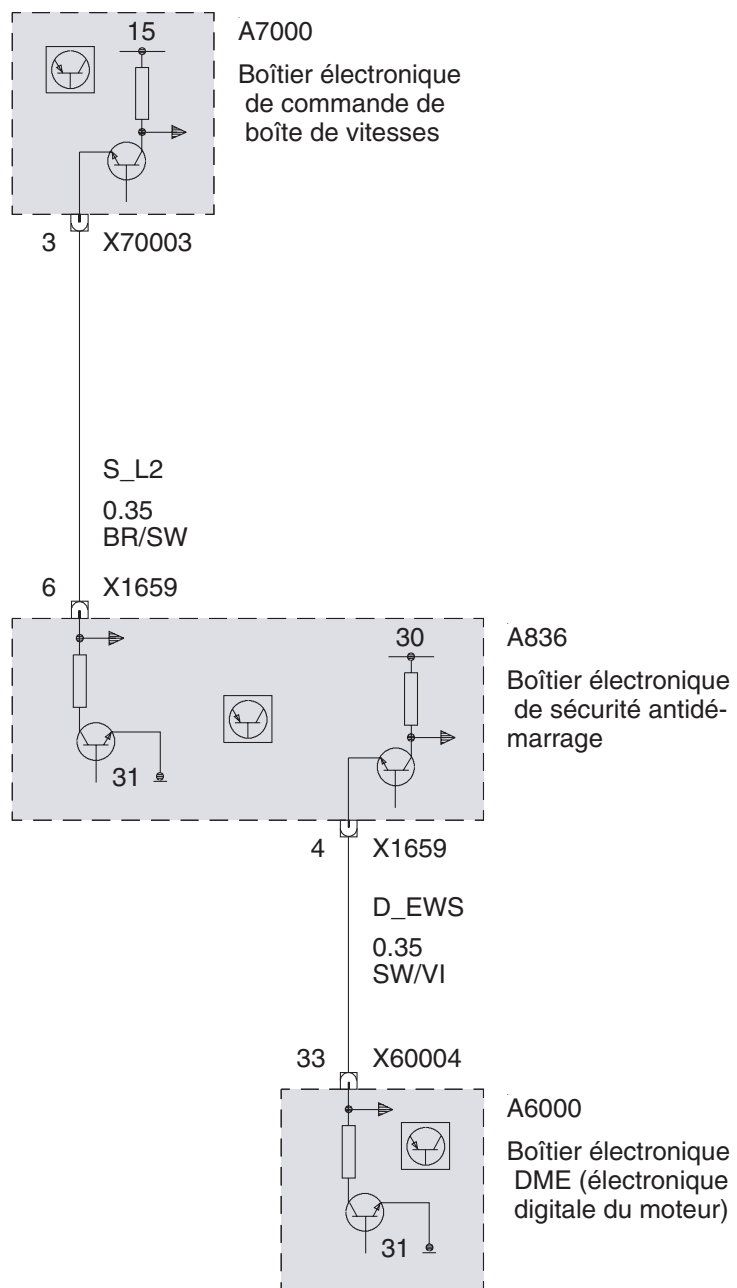

Insufflation d'air secondaire (325i\_M54 avec Boîte automatique ) ou (320i\_M54)

Système d'insufflation de l'air secondaire (jusque 2003\_03)

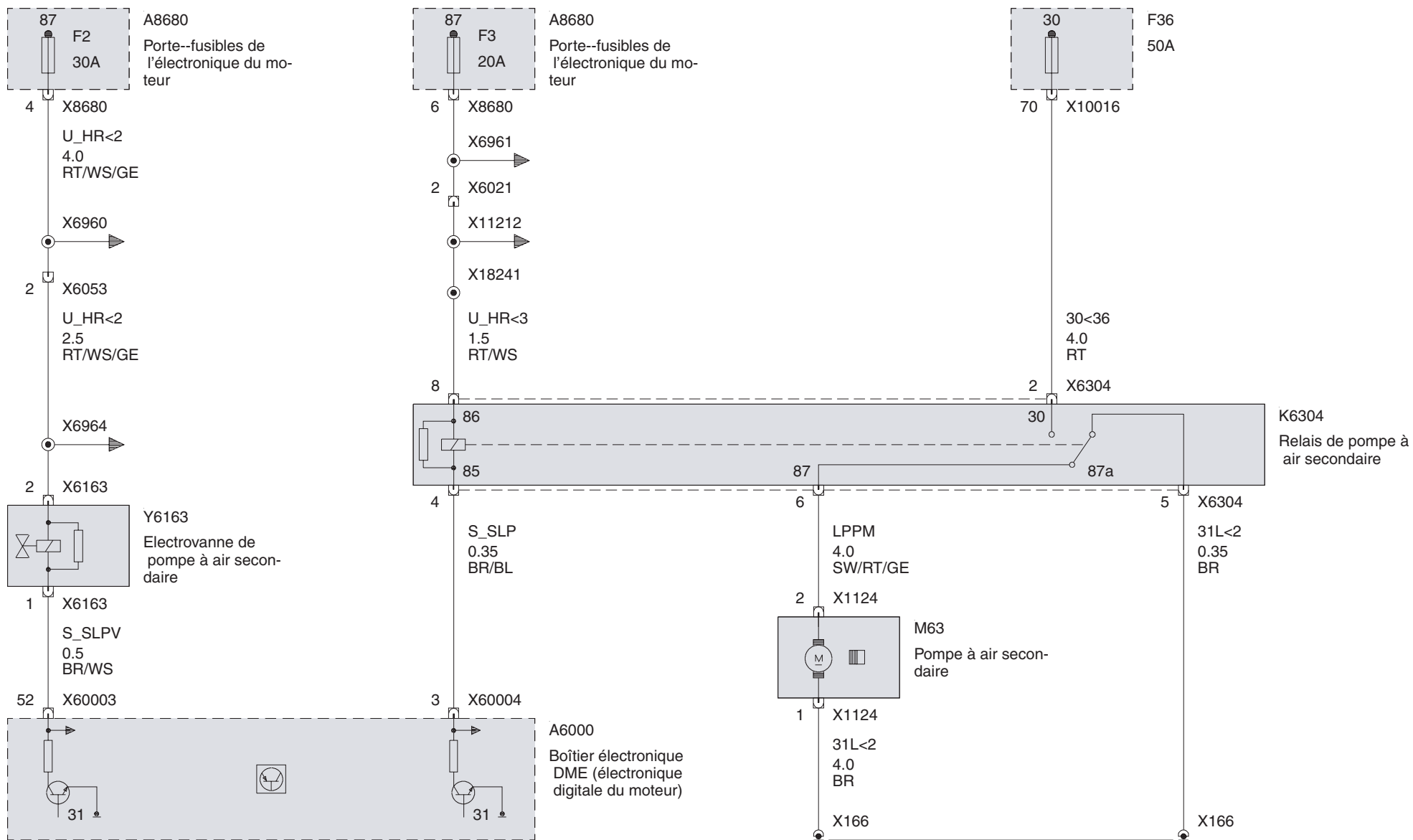

Systeme d'insufflation de l'air secondaire (à partir de 2003\_03)

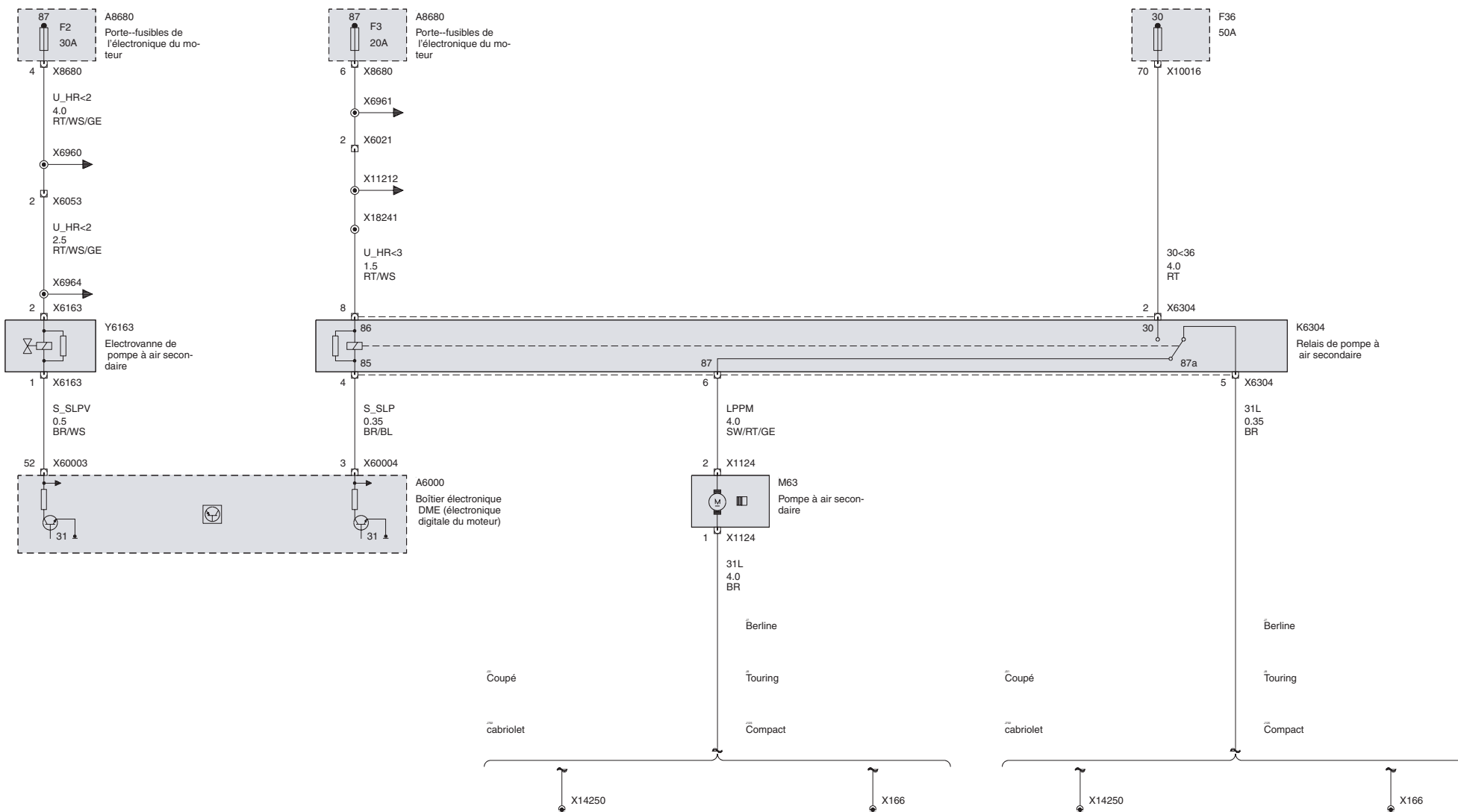

## Vanne de dégazage réservoir

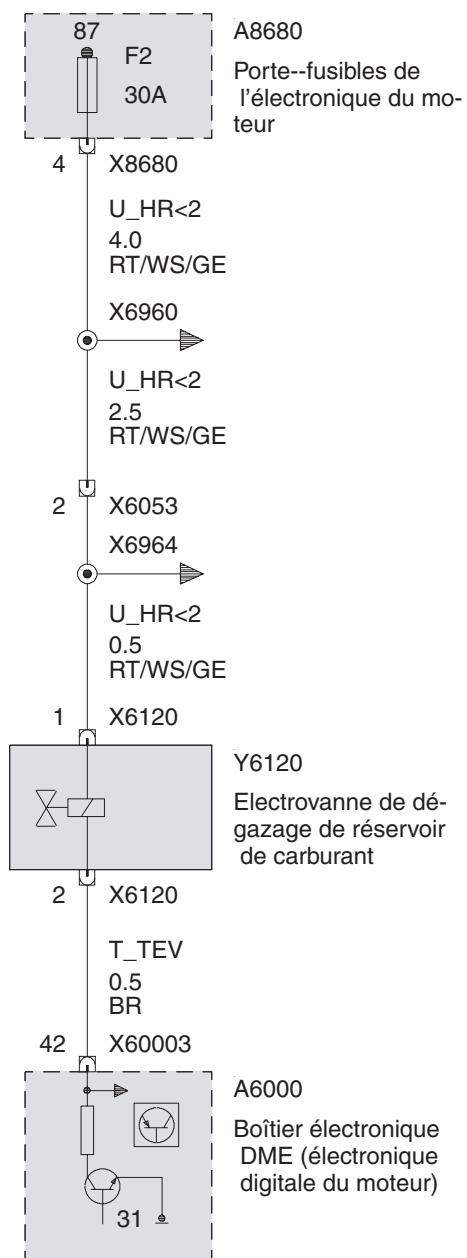

Alimentation en tension

Relais principal DME

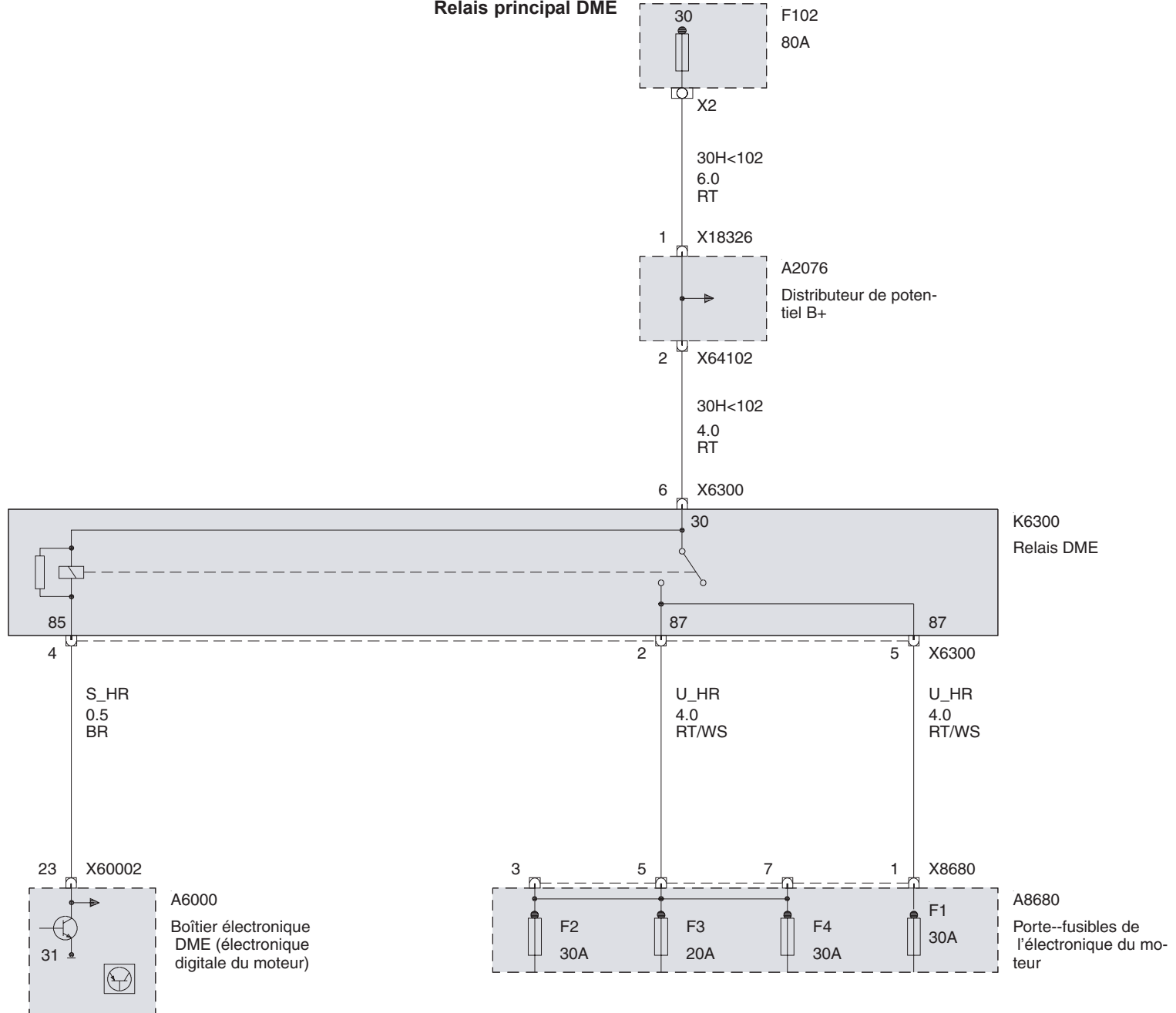

Alimentation Boîtier électronique DME

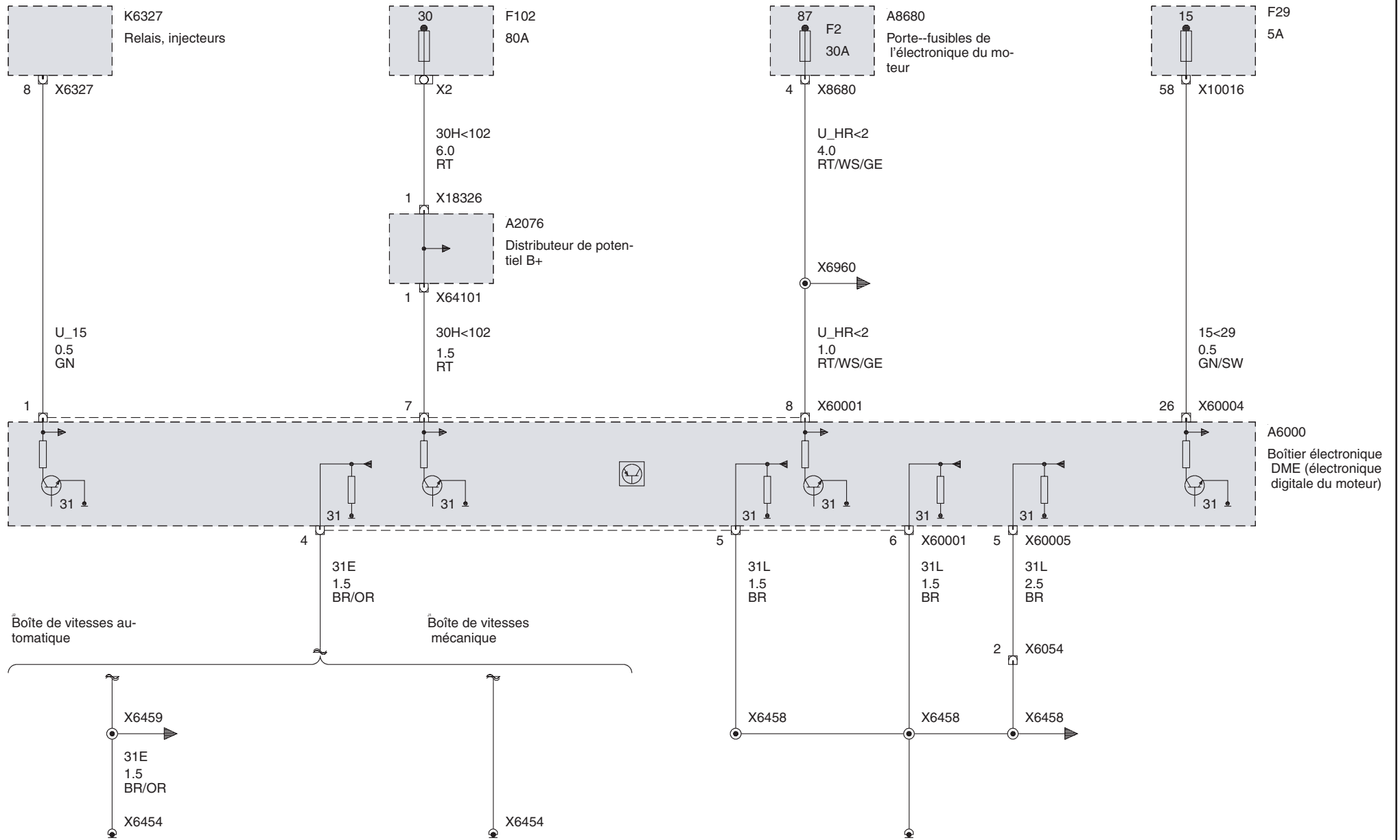

## Gestion moteur ME9 (DME Electronique moteur ME9)

### Préparation du mélange/allumage

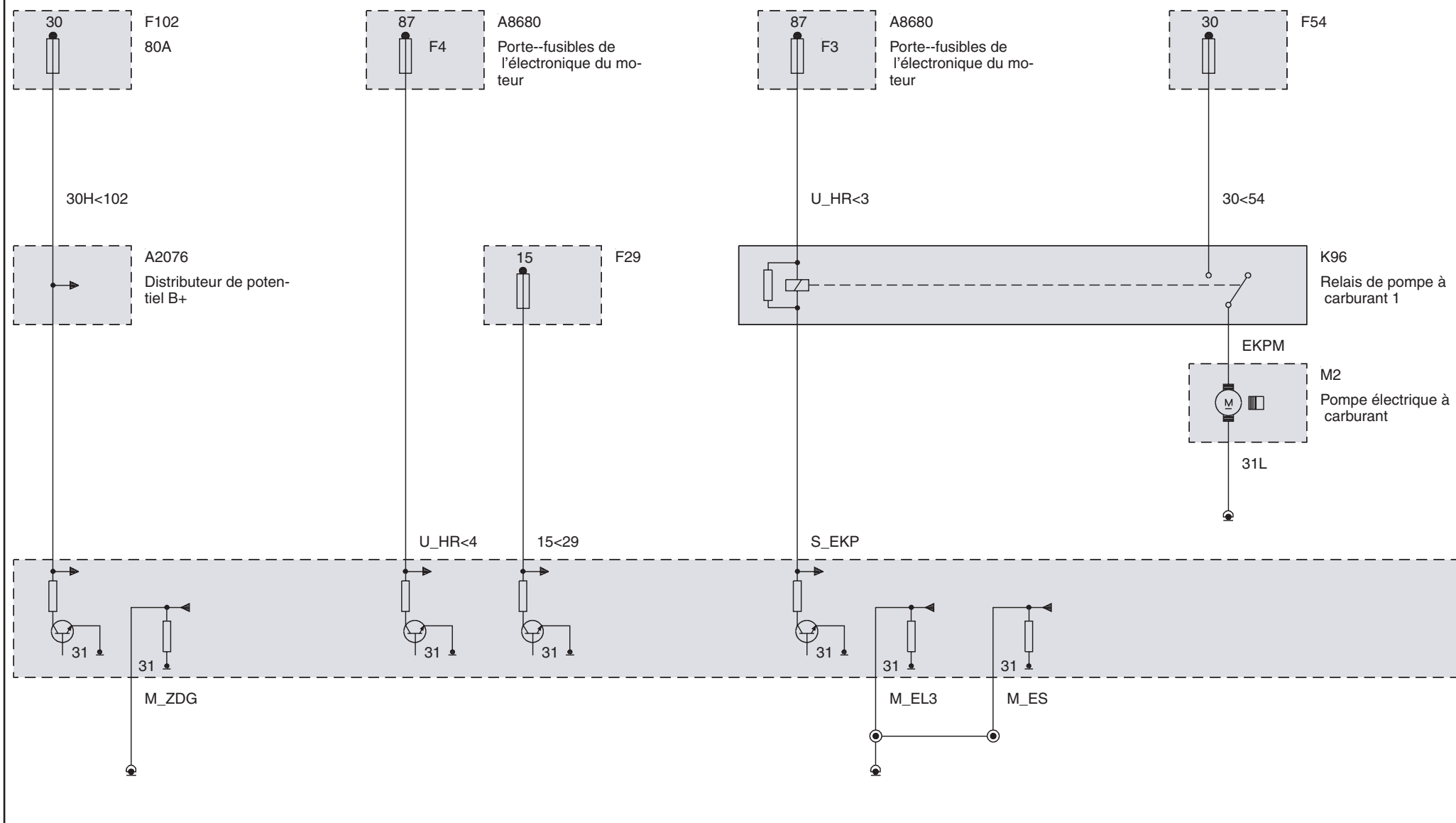



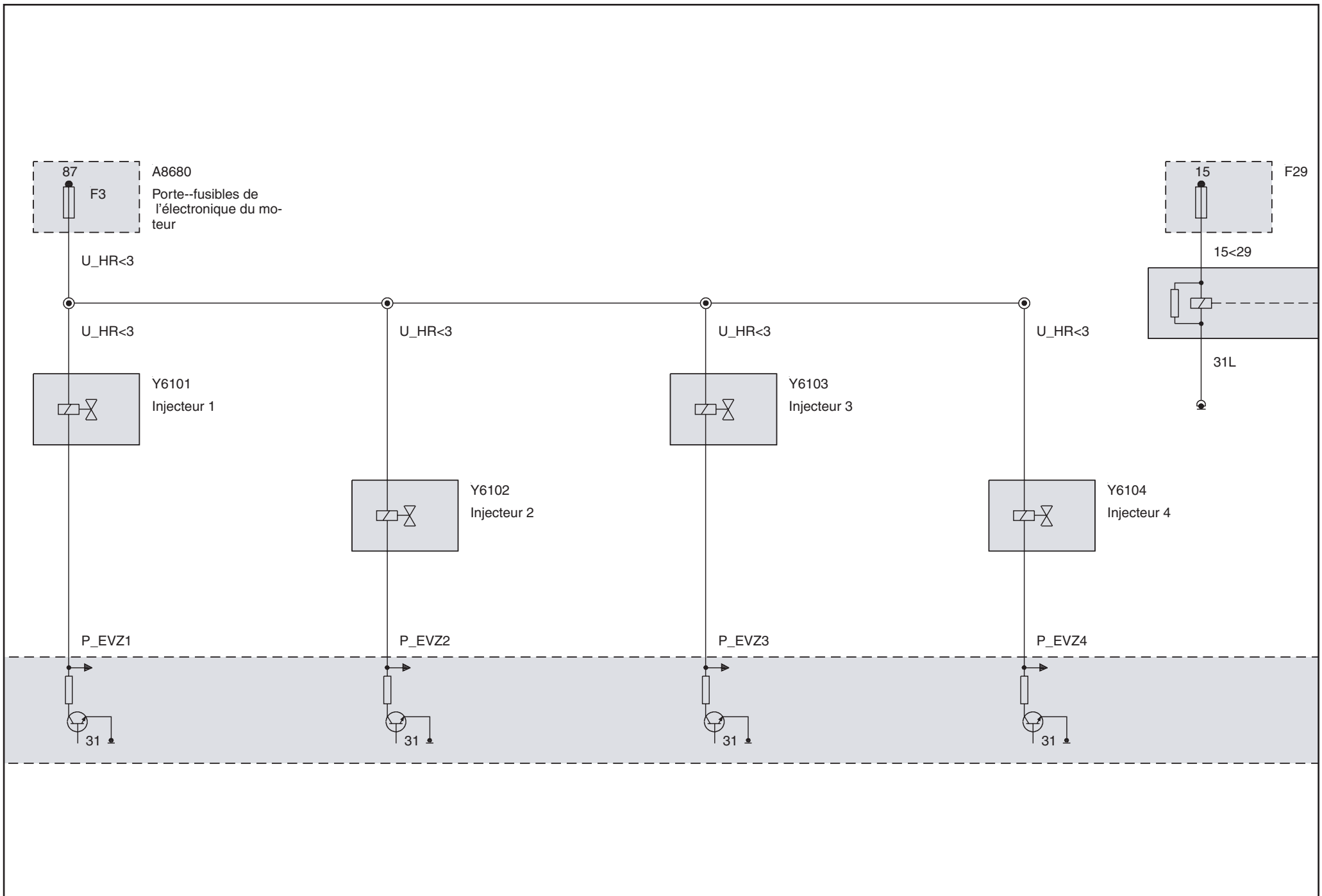

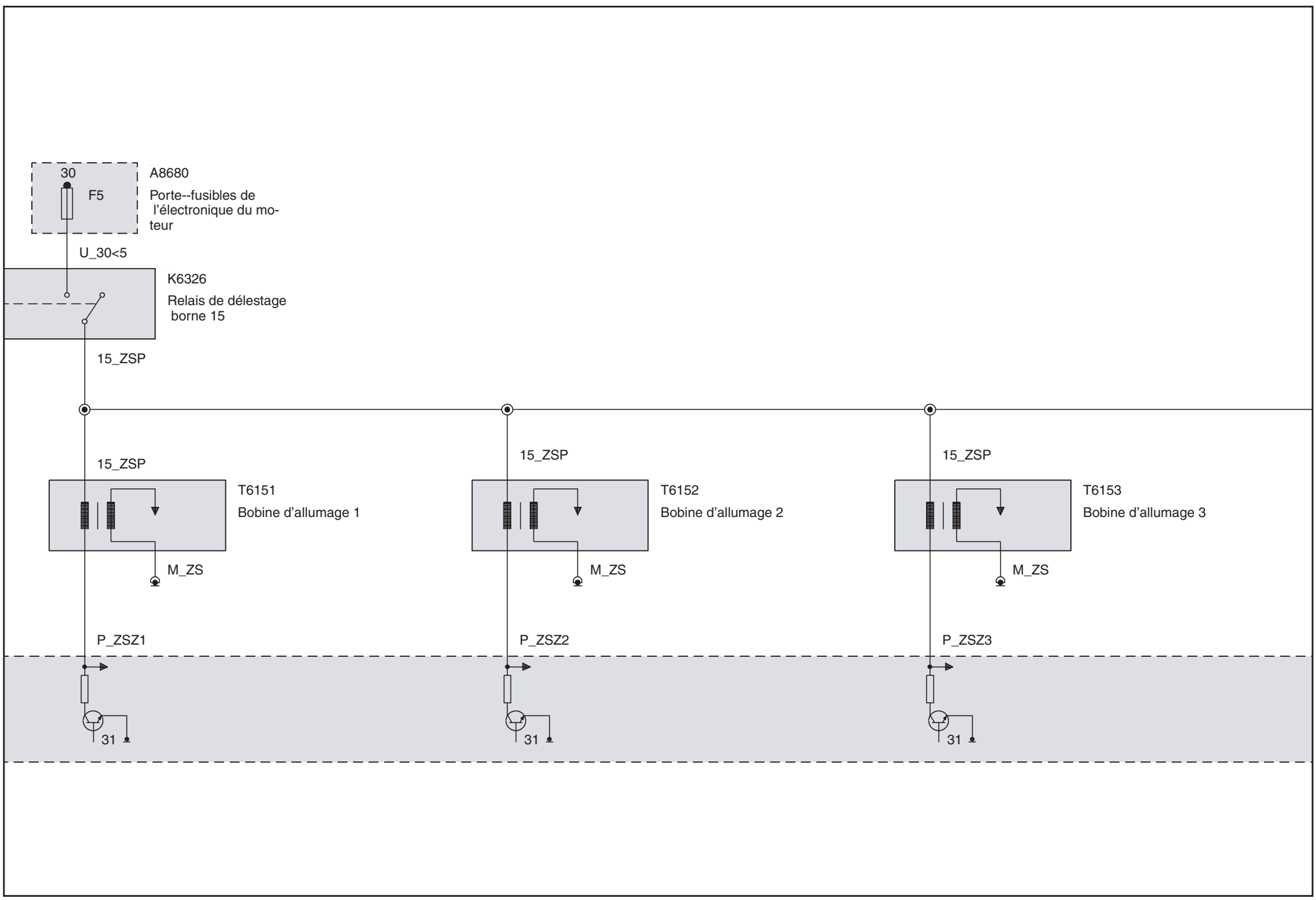

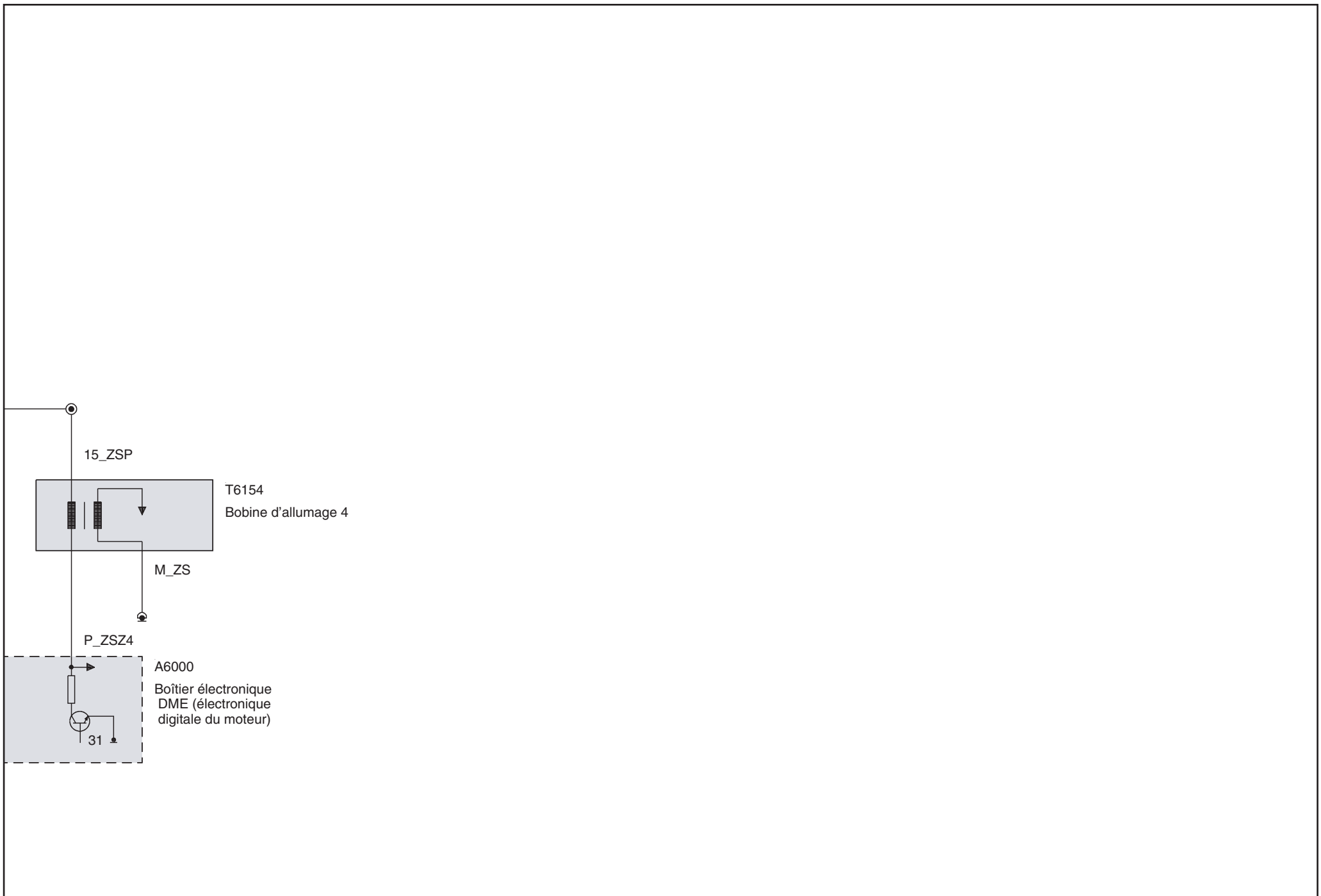

Paramètres d'entrée mélange/allumage (Moteur N42)

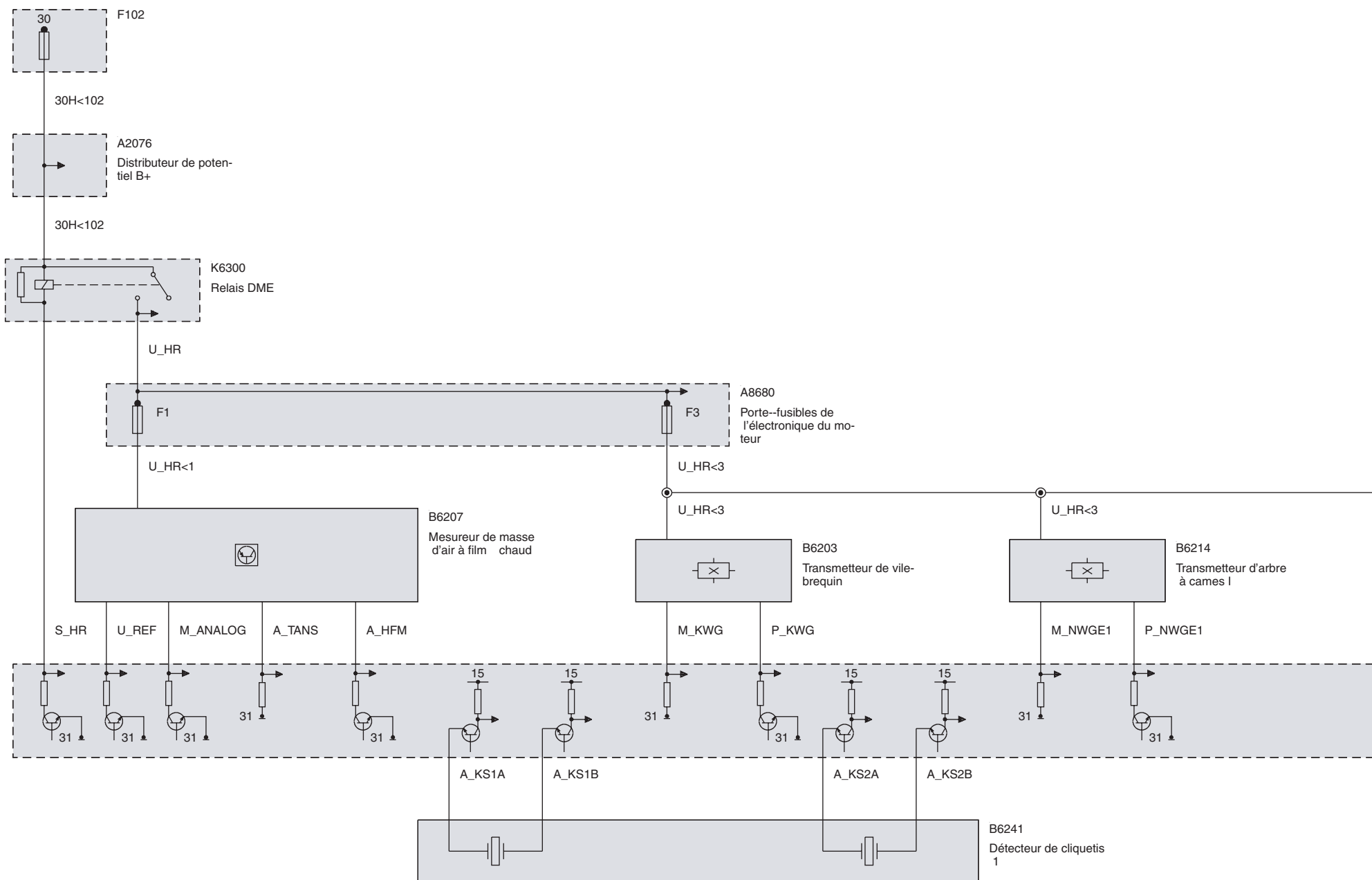

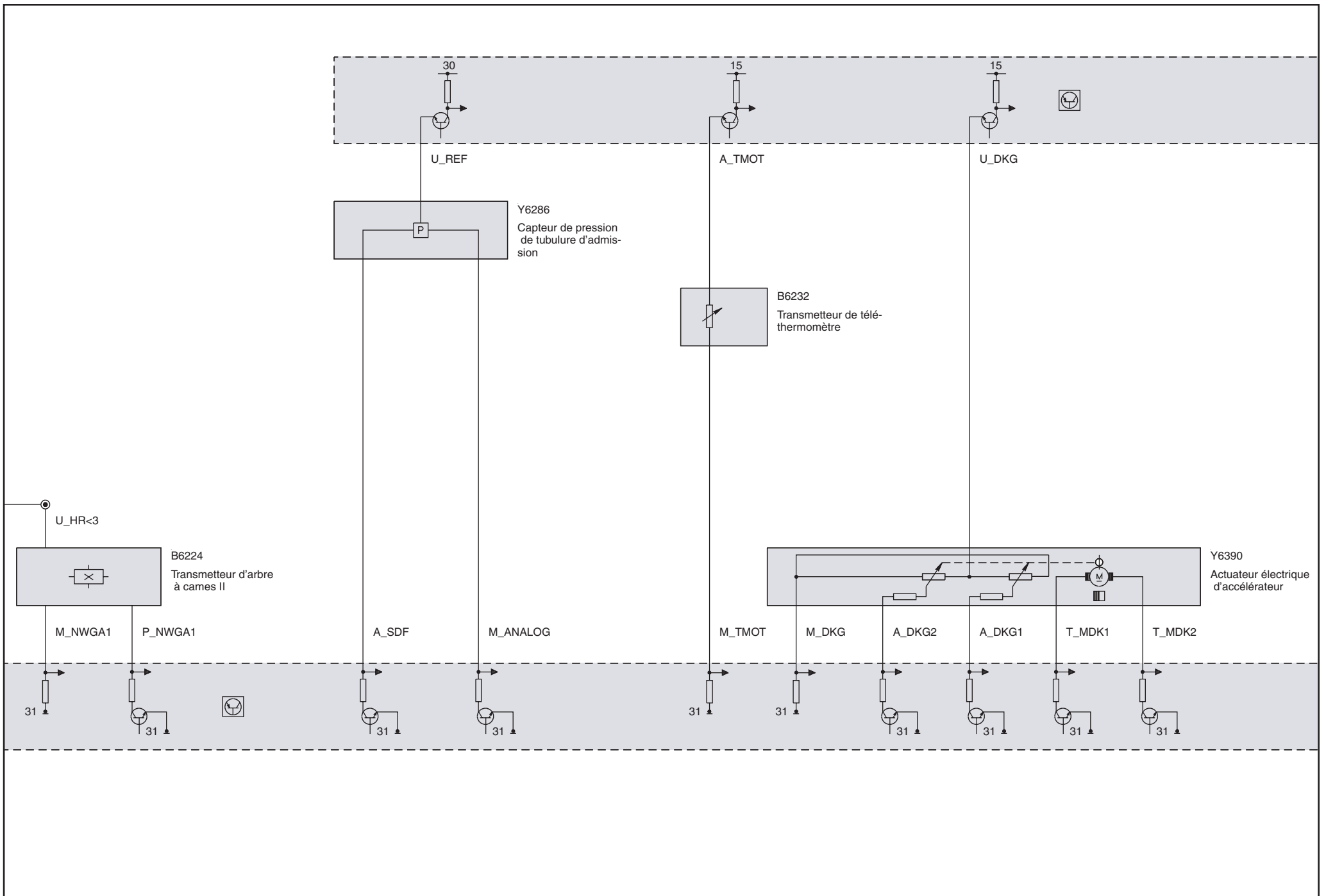

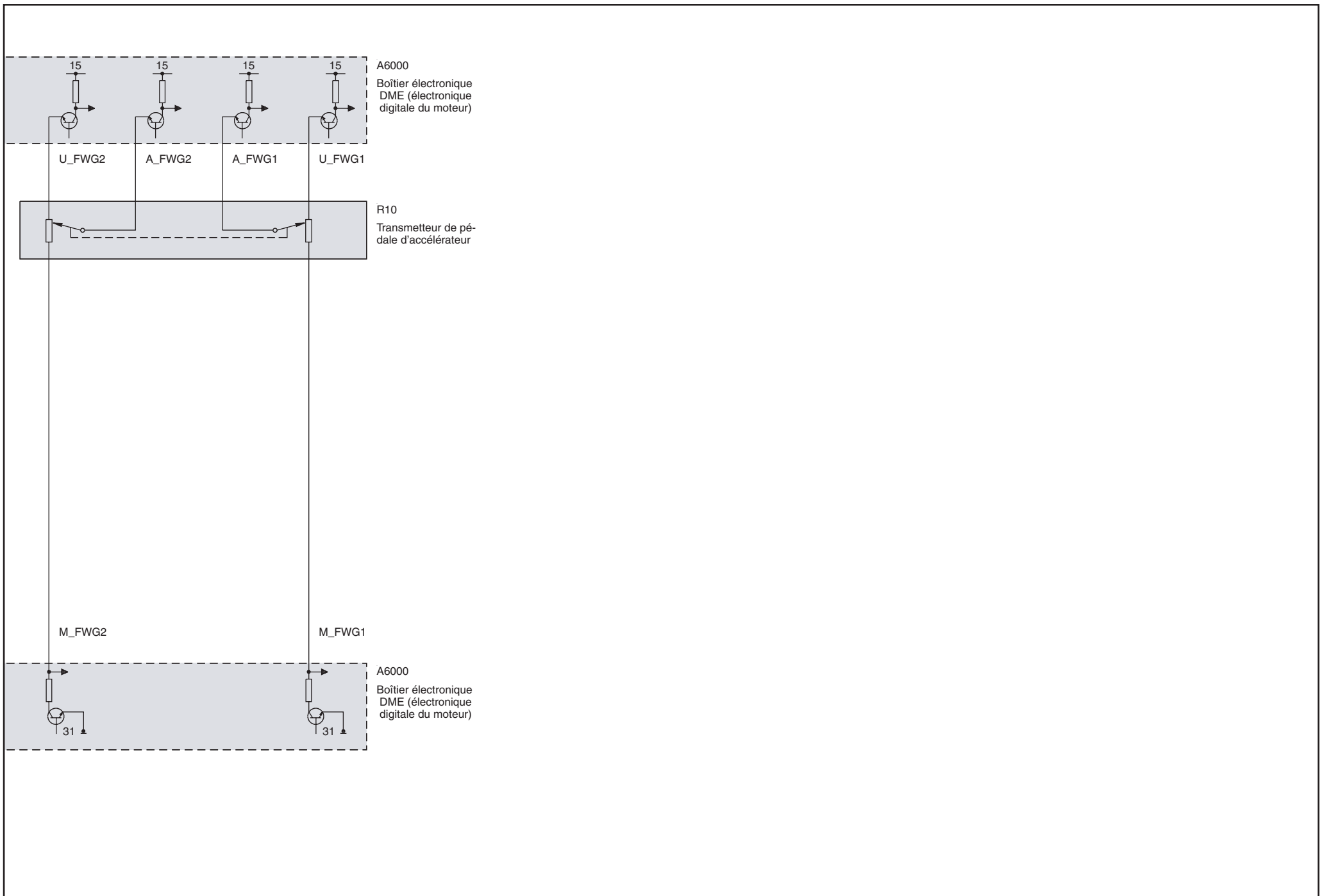

Commande du moteur, fonctions auxiliaires (Moteur N42)

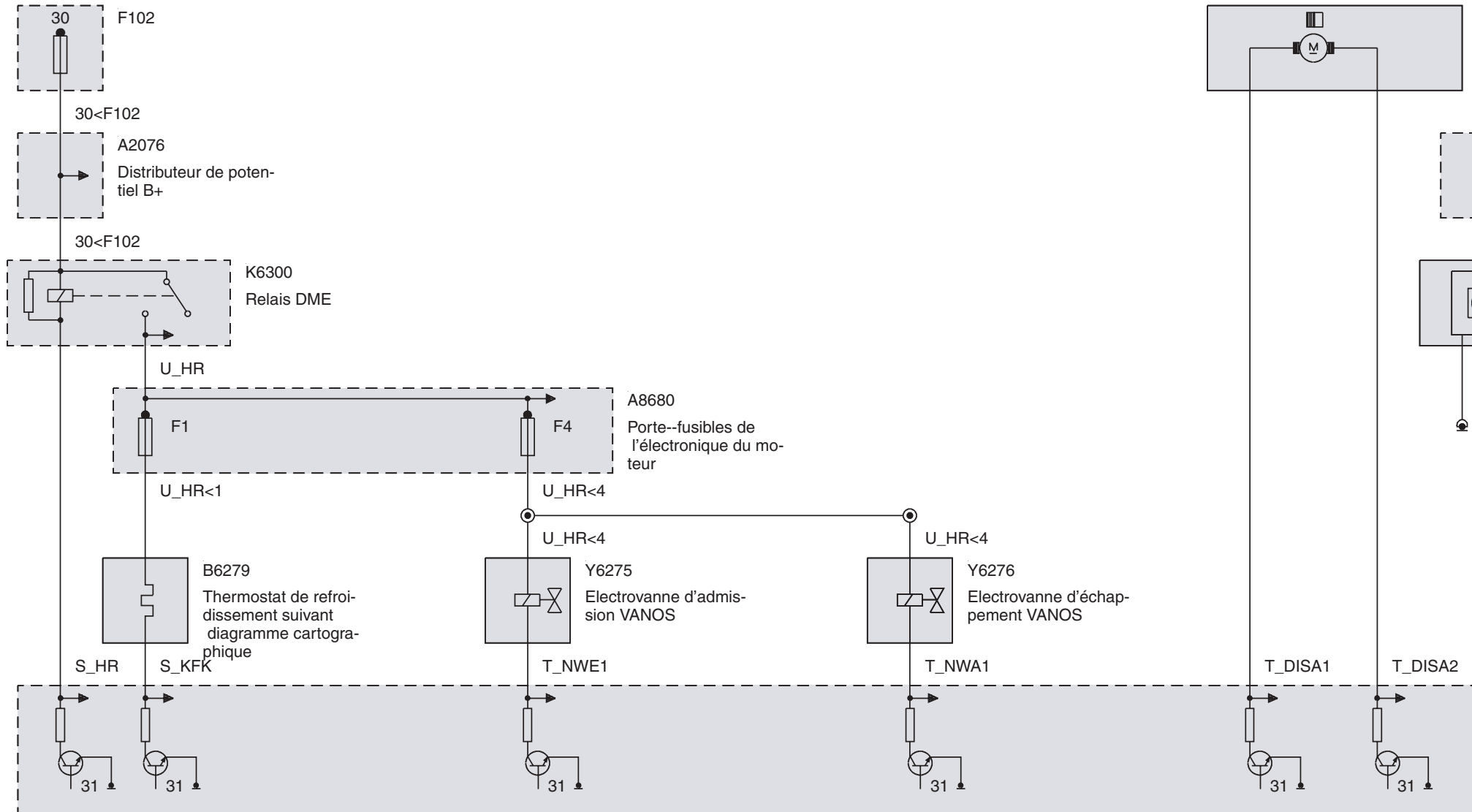

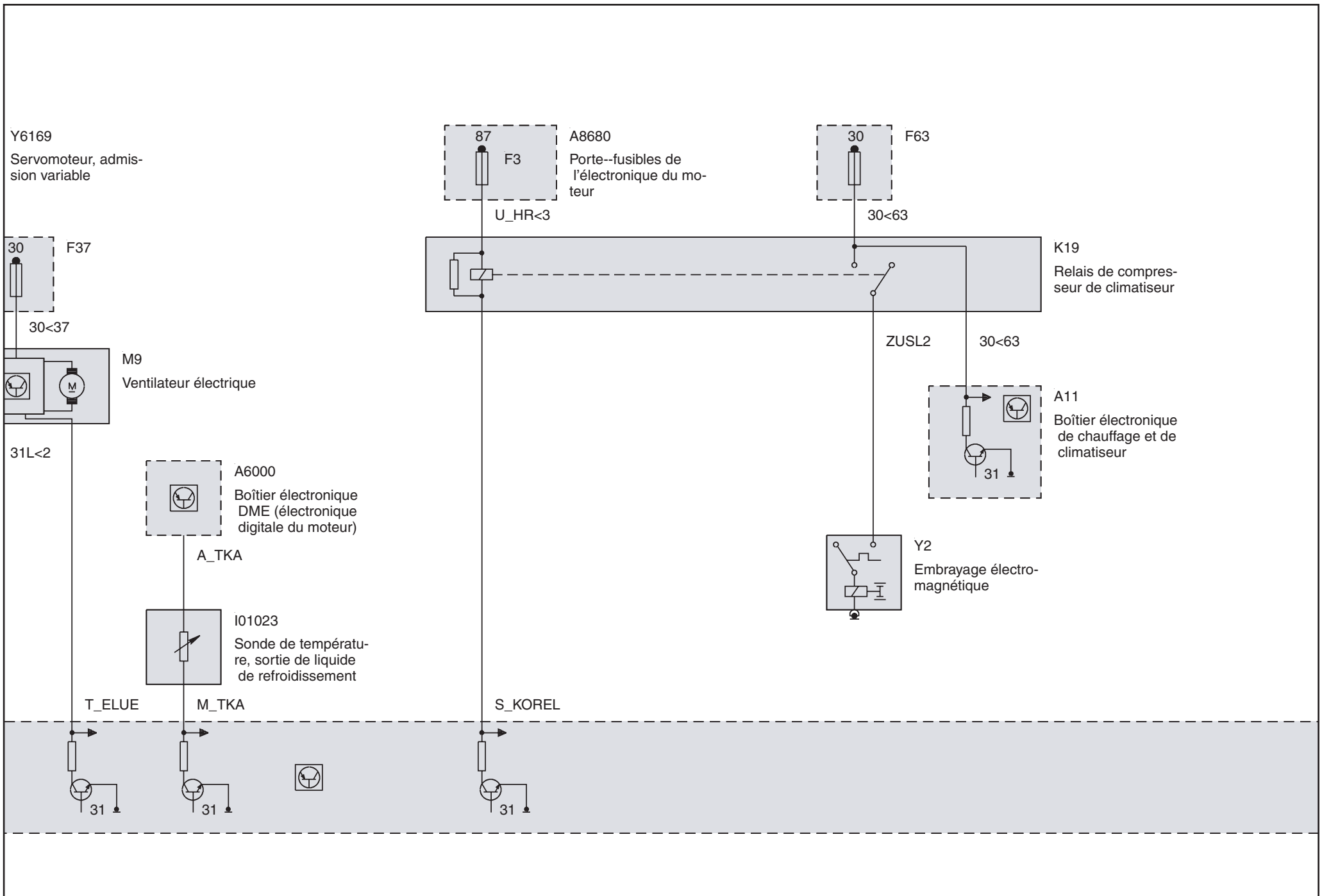



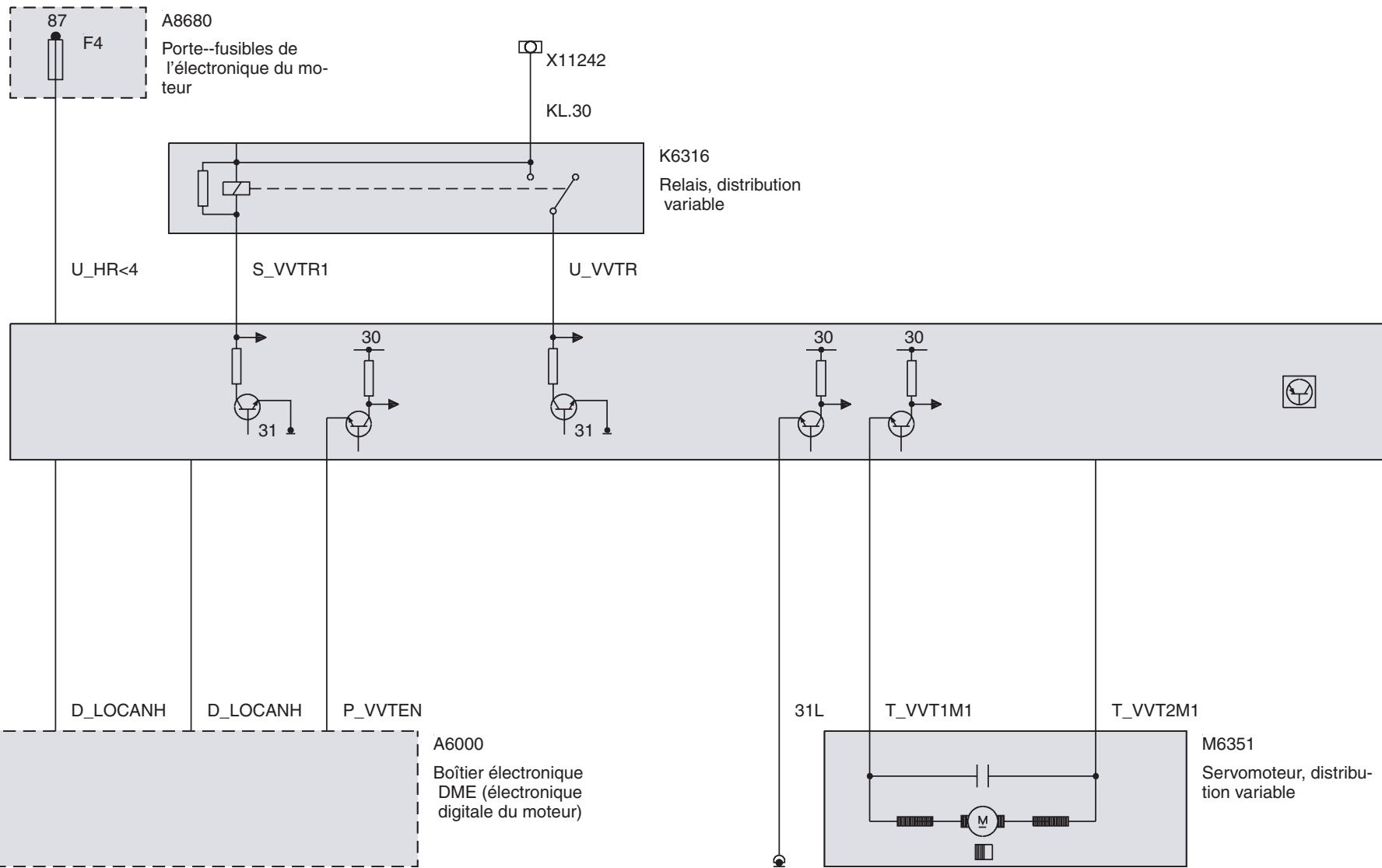

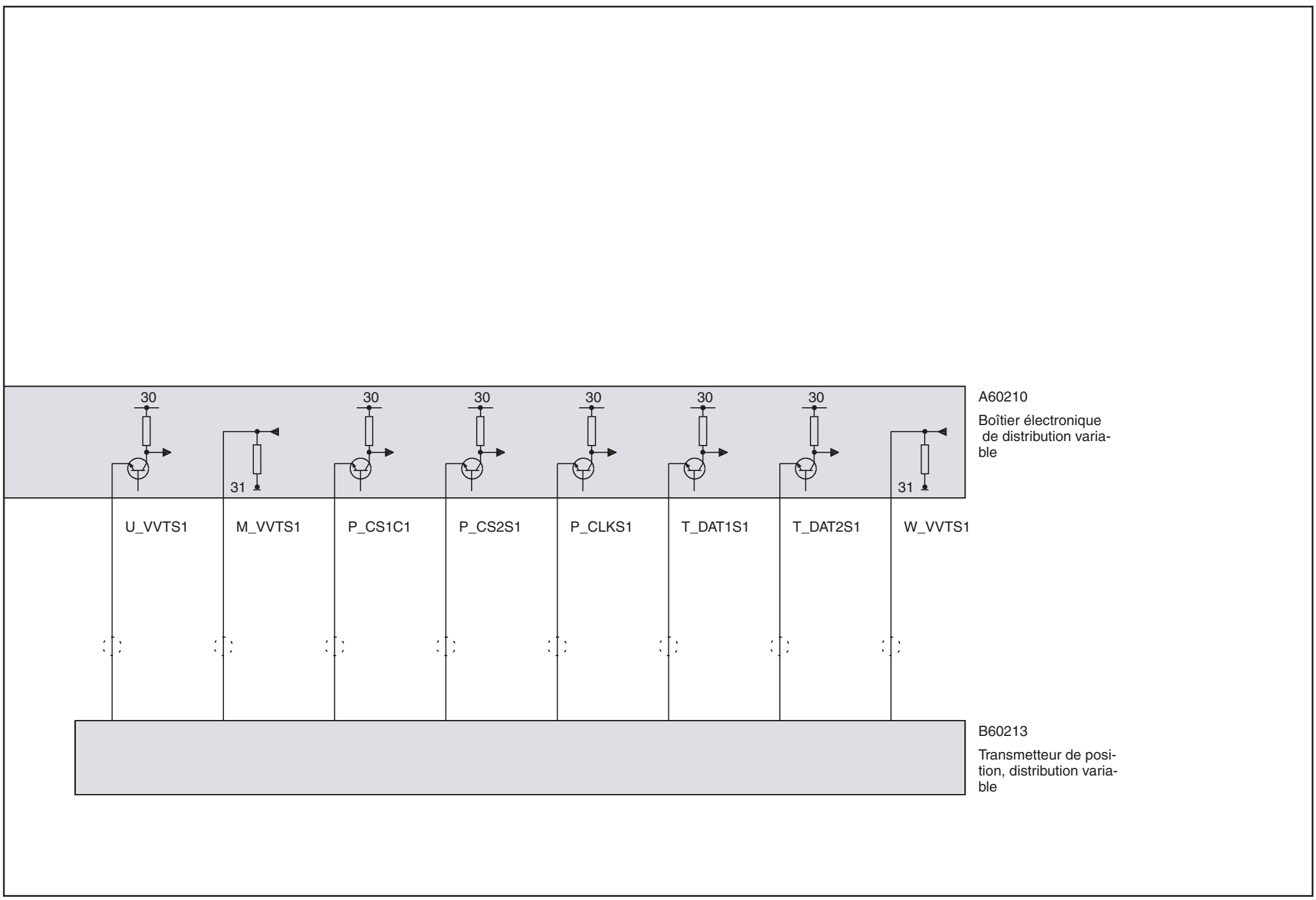

A60210  
Boîtier électronique  
de distribution varia-  
ble

B60213  
Transmetteur de posi-  
tion, distribution varia-  
ble

Régulation/épuration/contrôle des gaz d'échappement (Moteur N42)

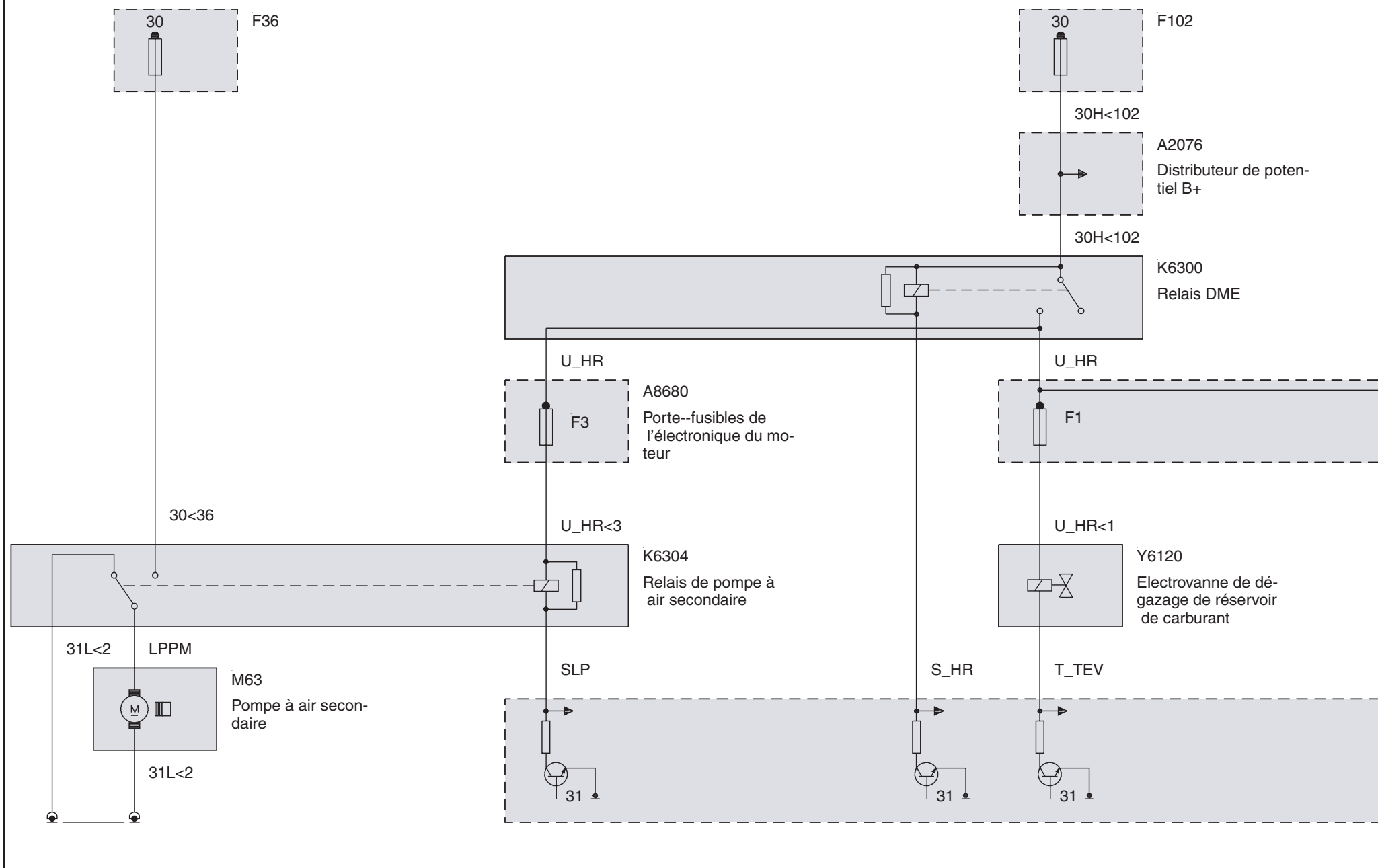

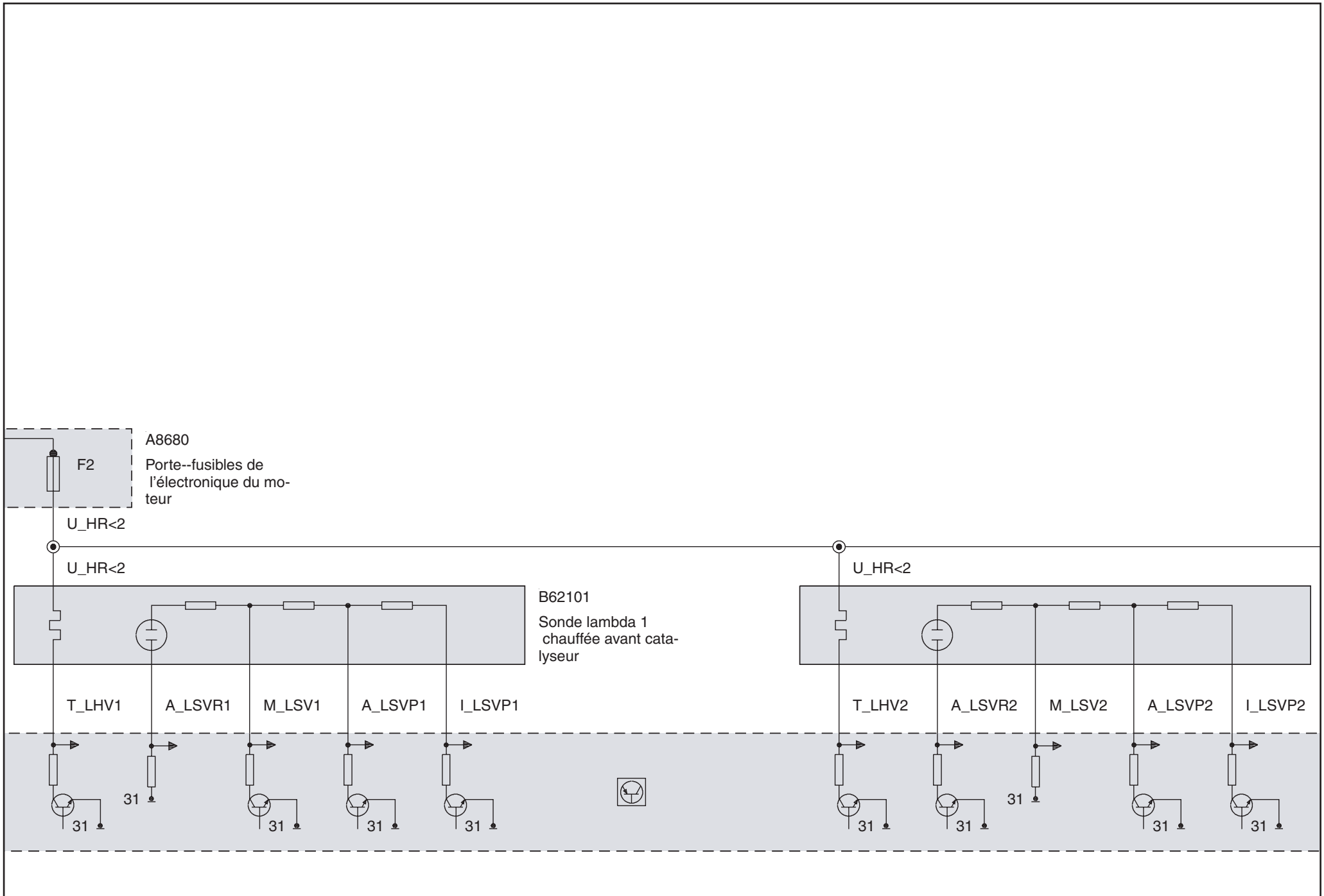

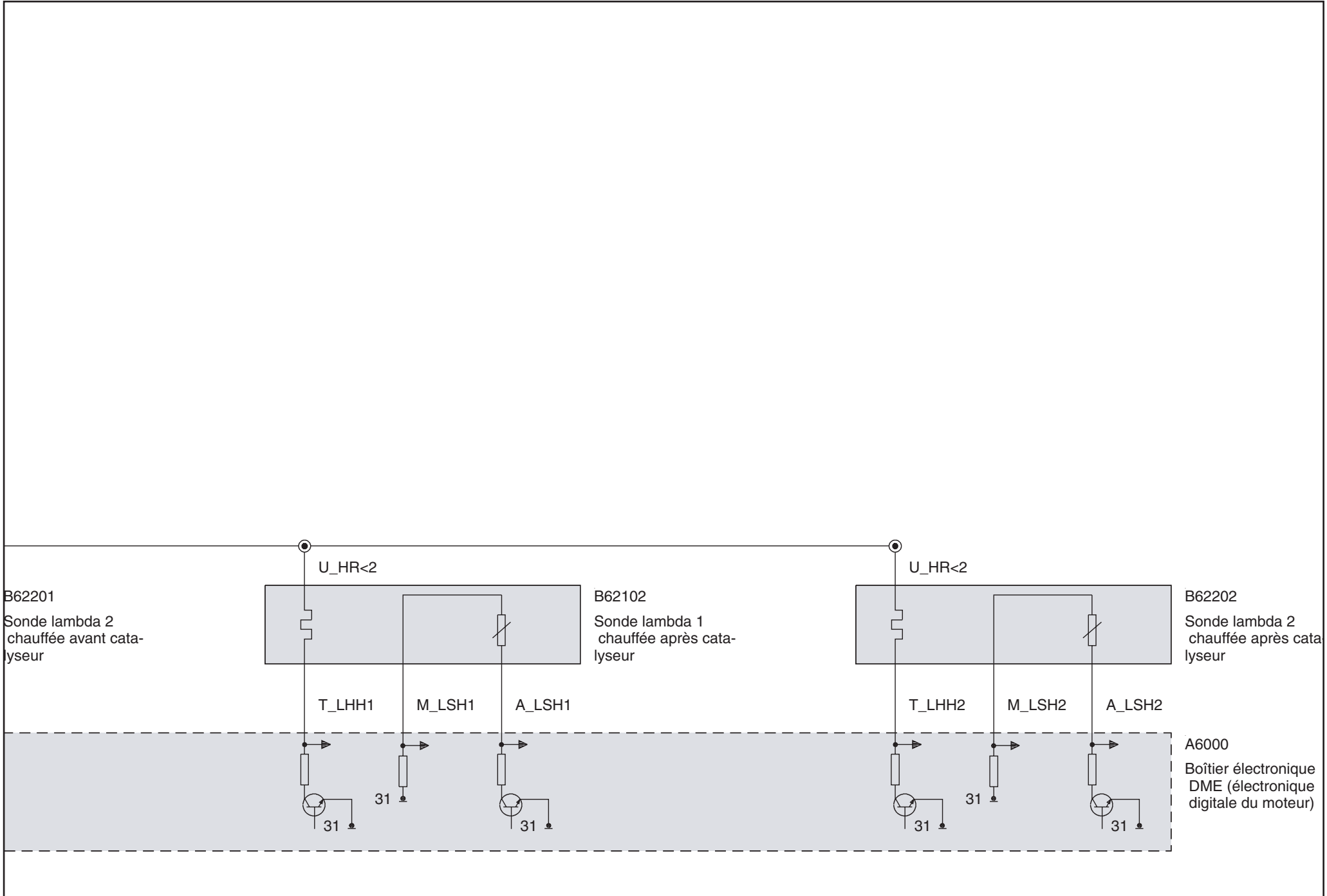

Commande du moteur, signaux/signaux auxiliaires (sans Boîte automatique)

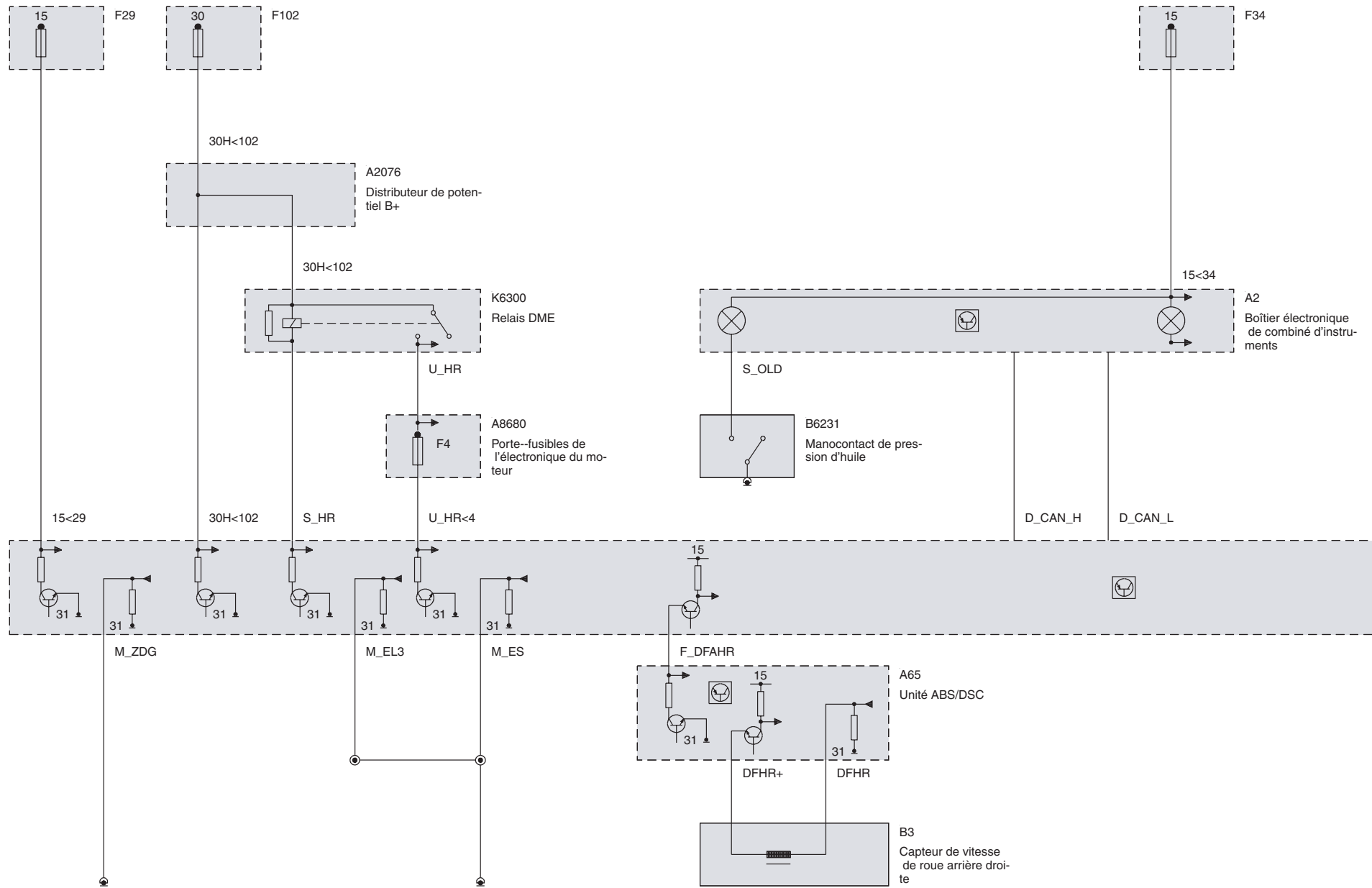

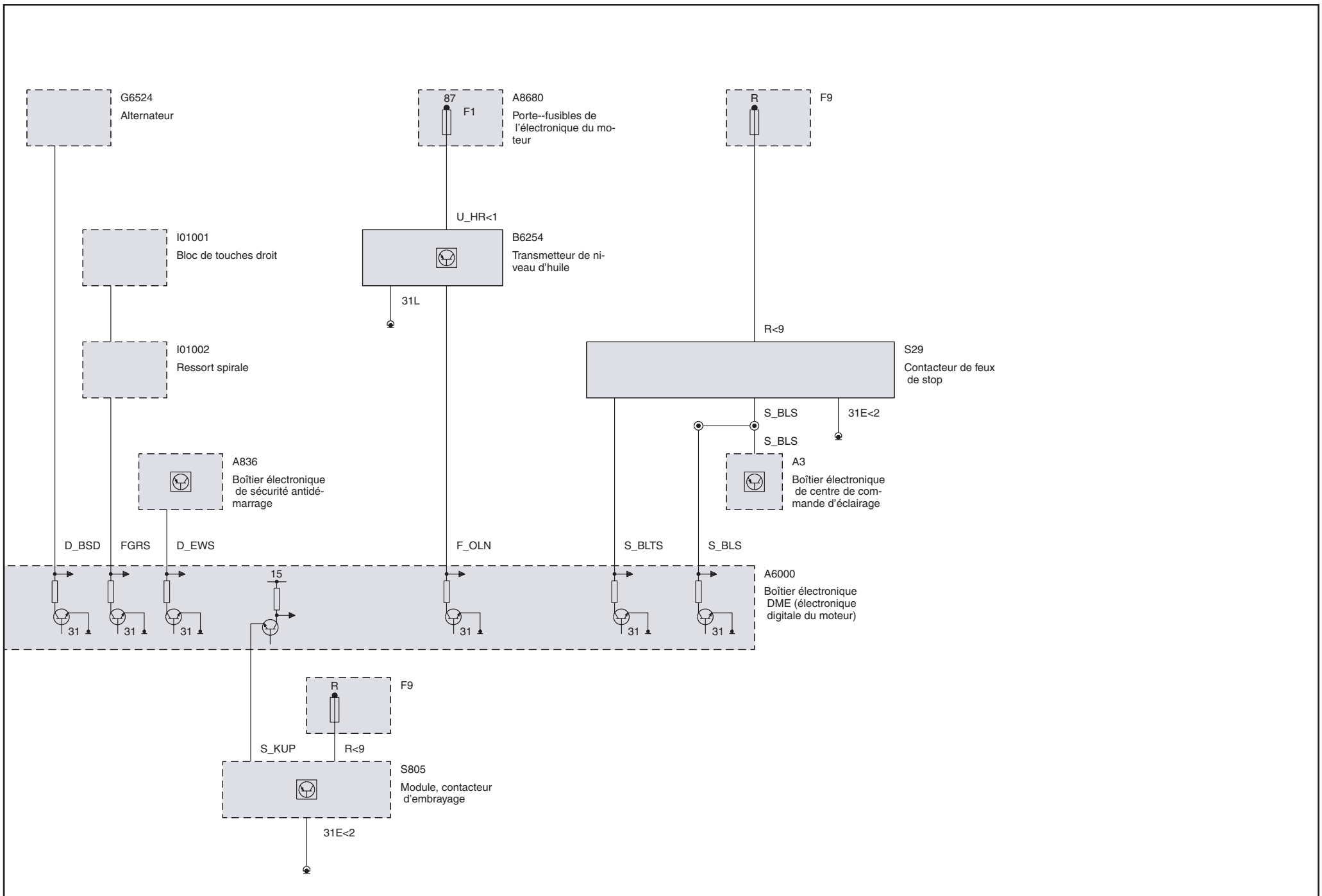

Commande du moteur, signaux/signaux auxiliaires (Boîte automatique)

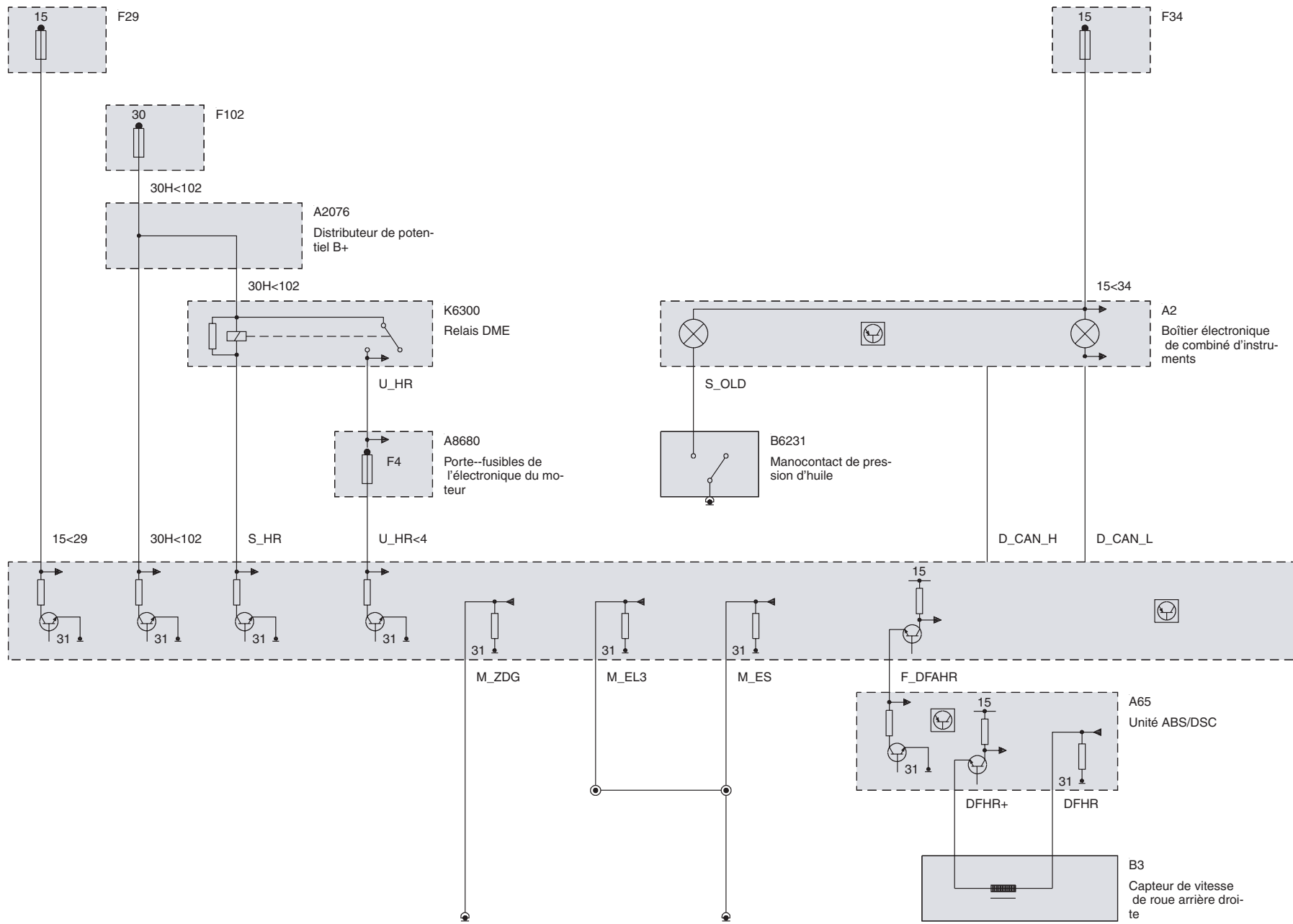



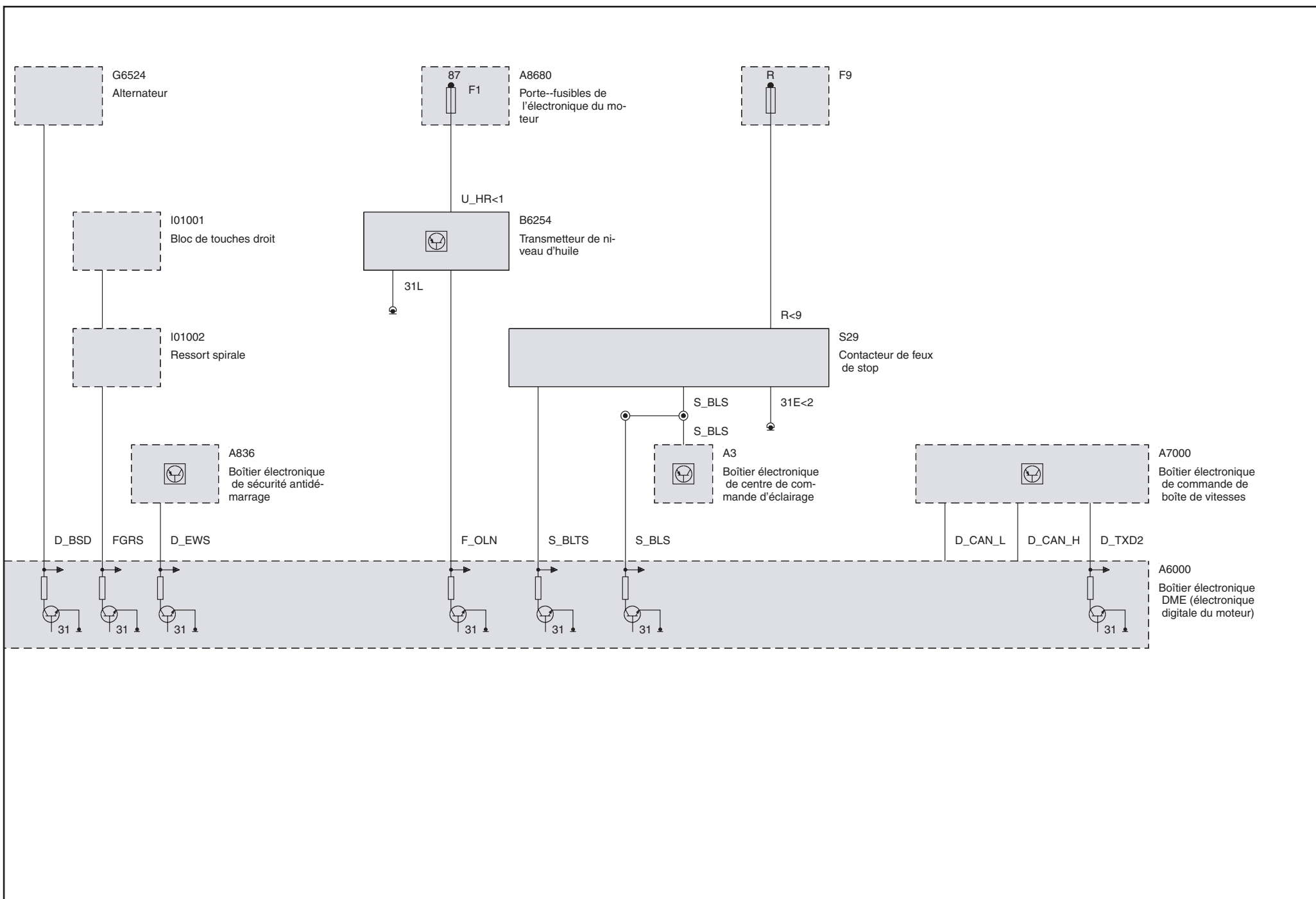

Paramètres d'entrée mélange/allumage (Moteur N40 ou Moteur N45)

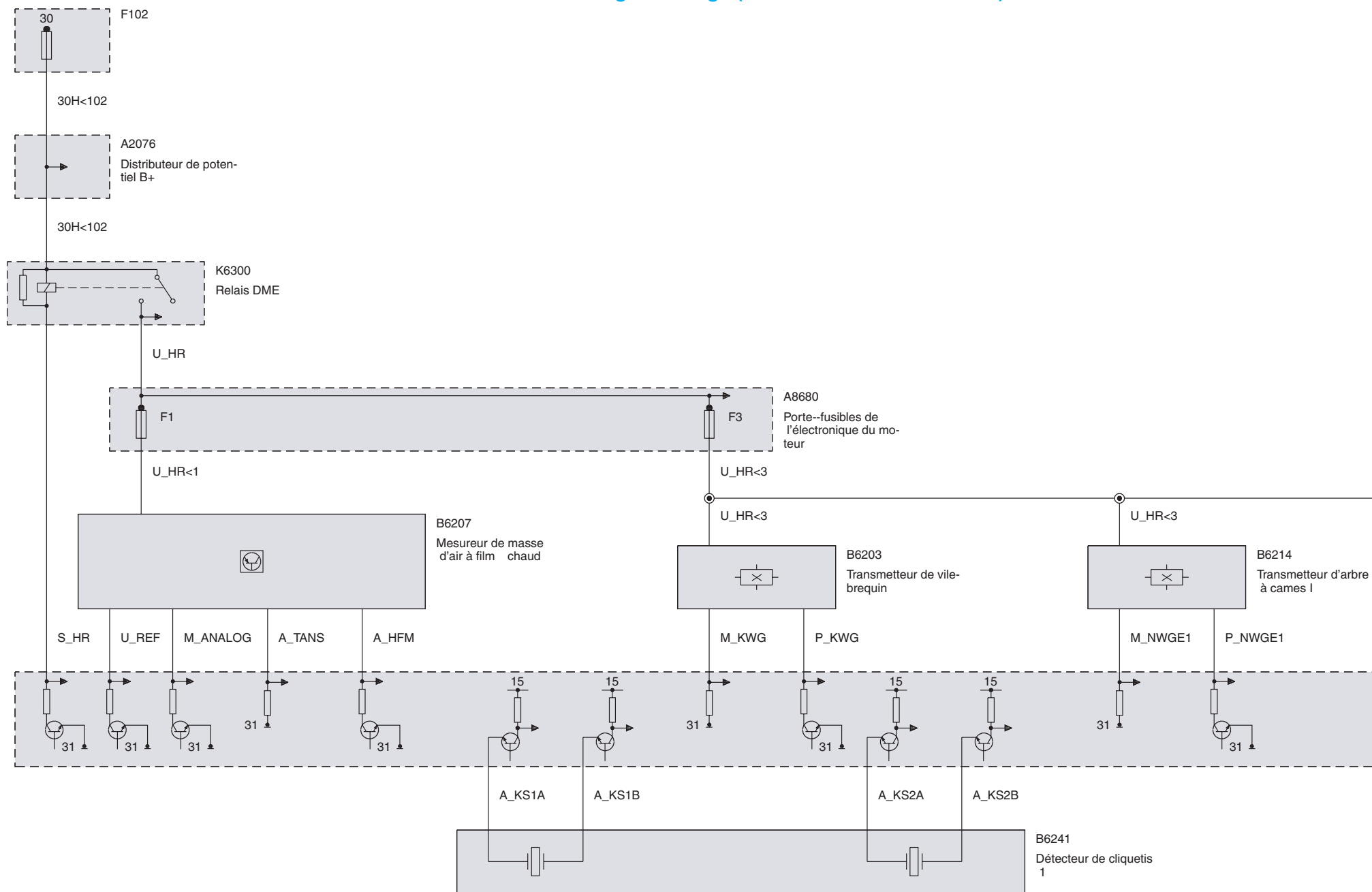

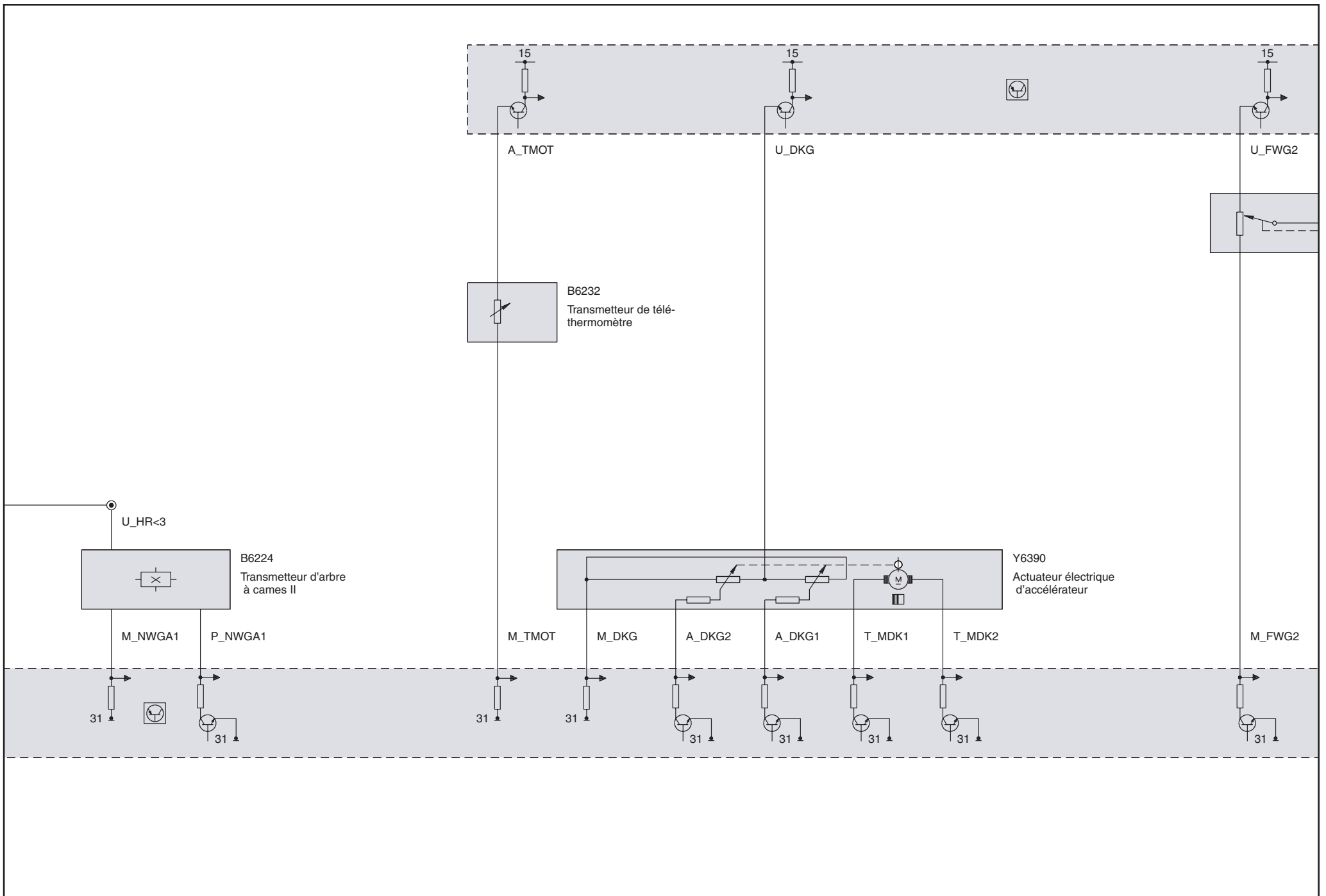

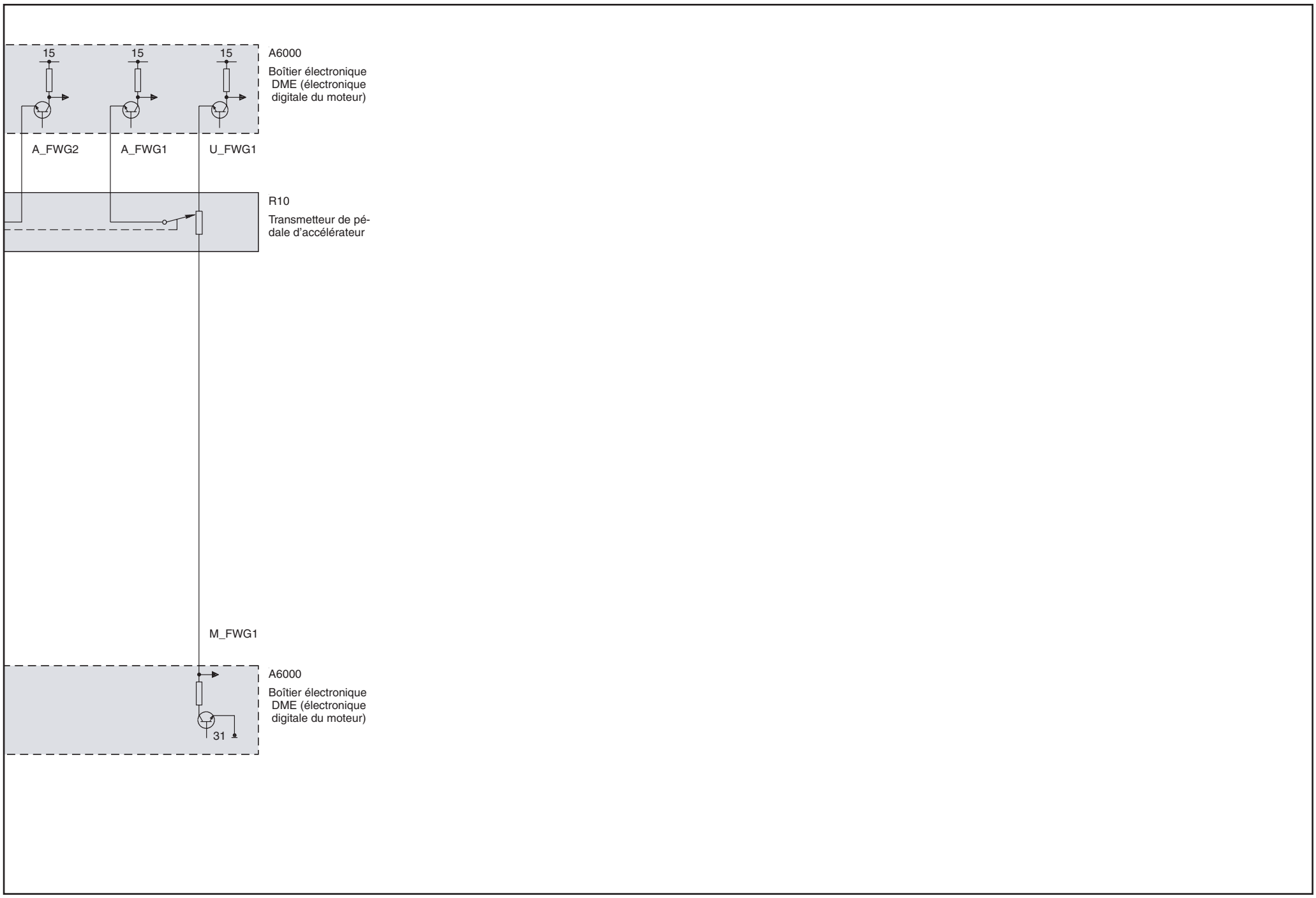

Commande du moteur, fonctions auxiliaires (Moteur N40 ou Moteur N45)

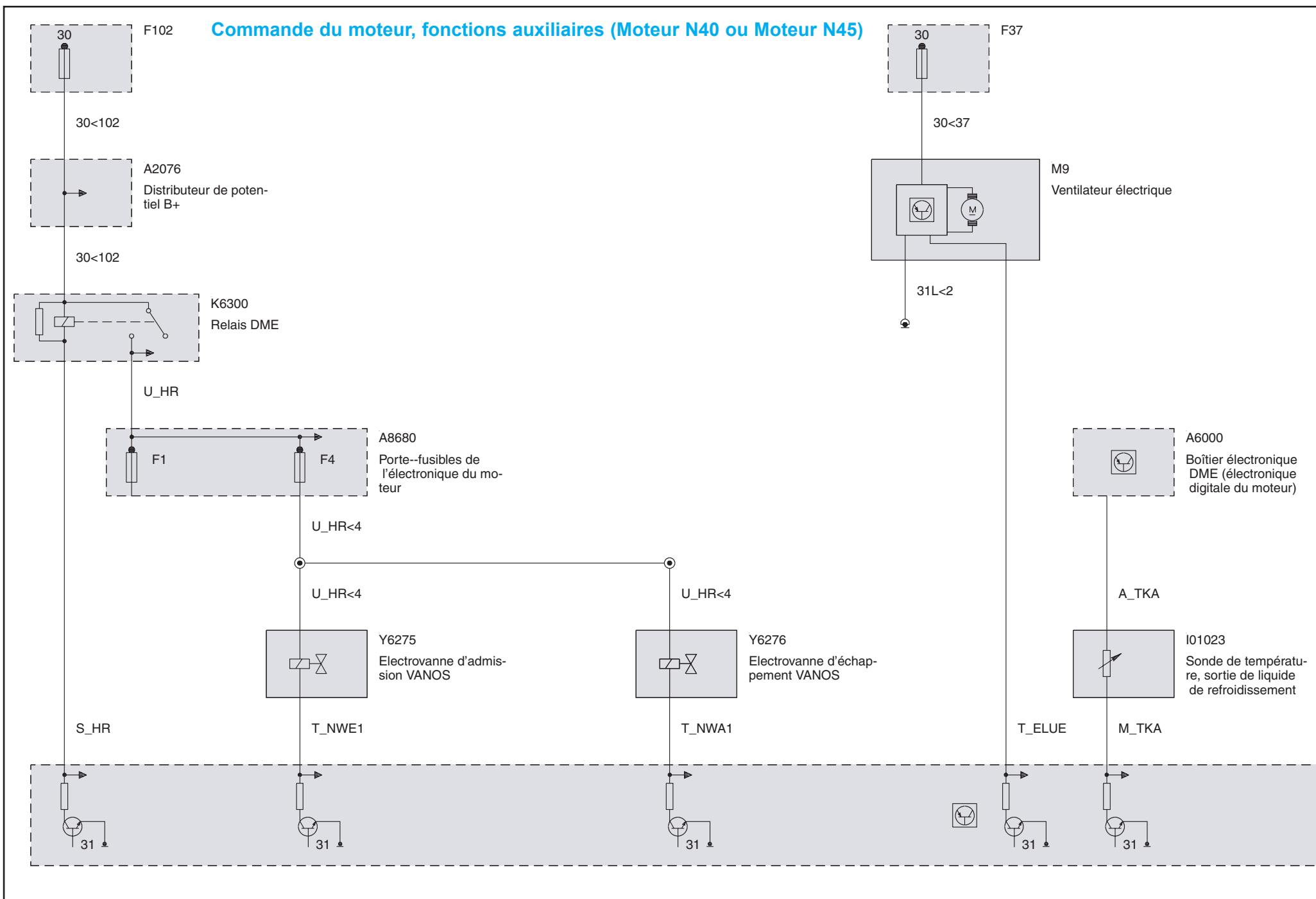

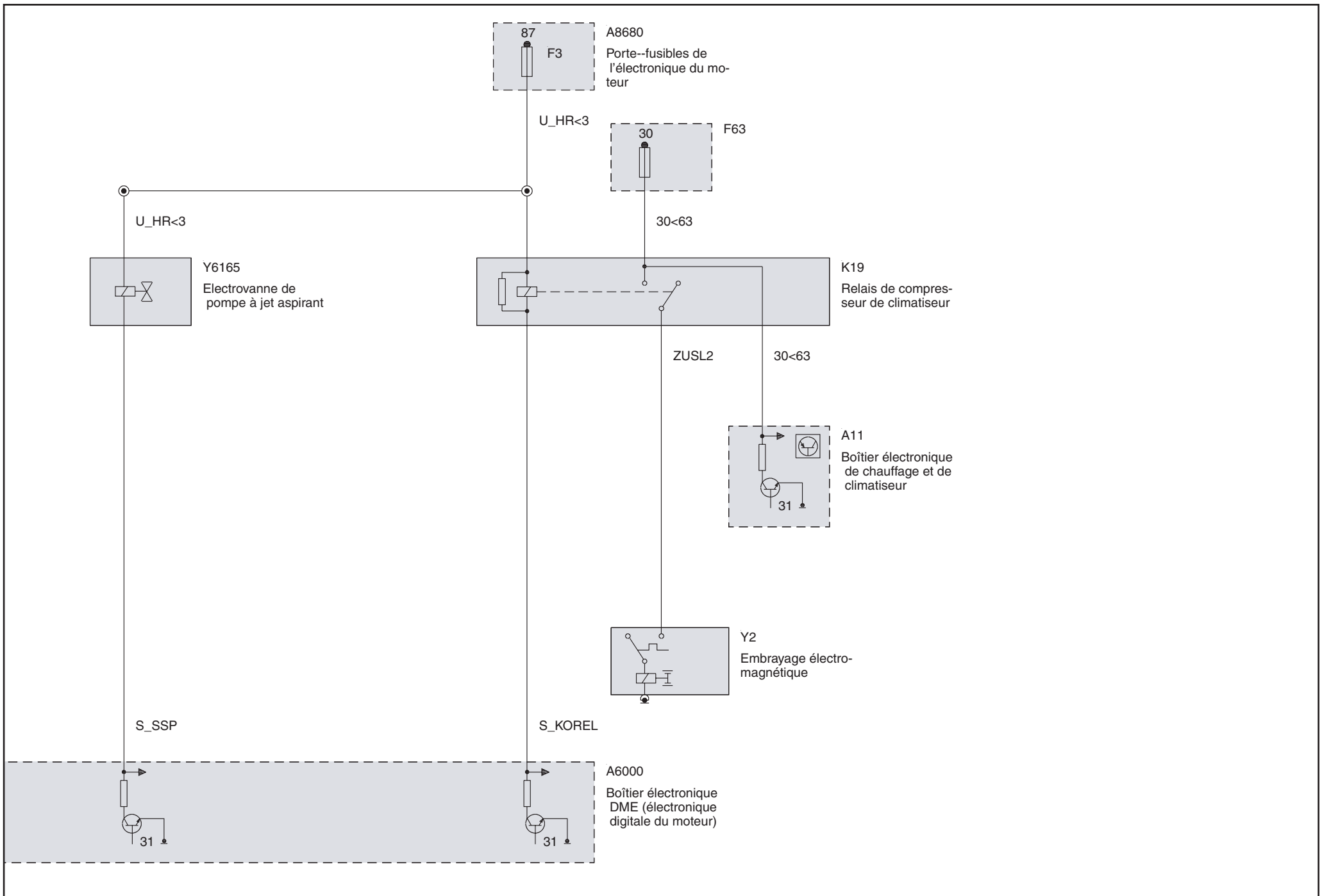

Régulation/épuration/contrôle des gaz d'échappement (Moteur N40 ou Moteur N45)

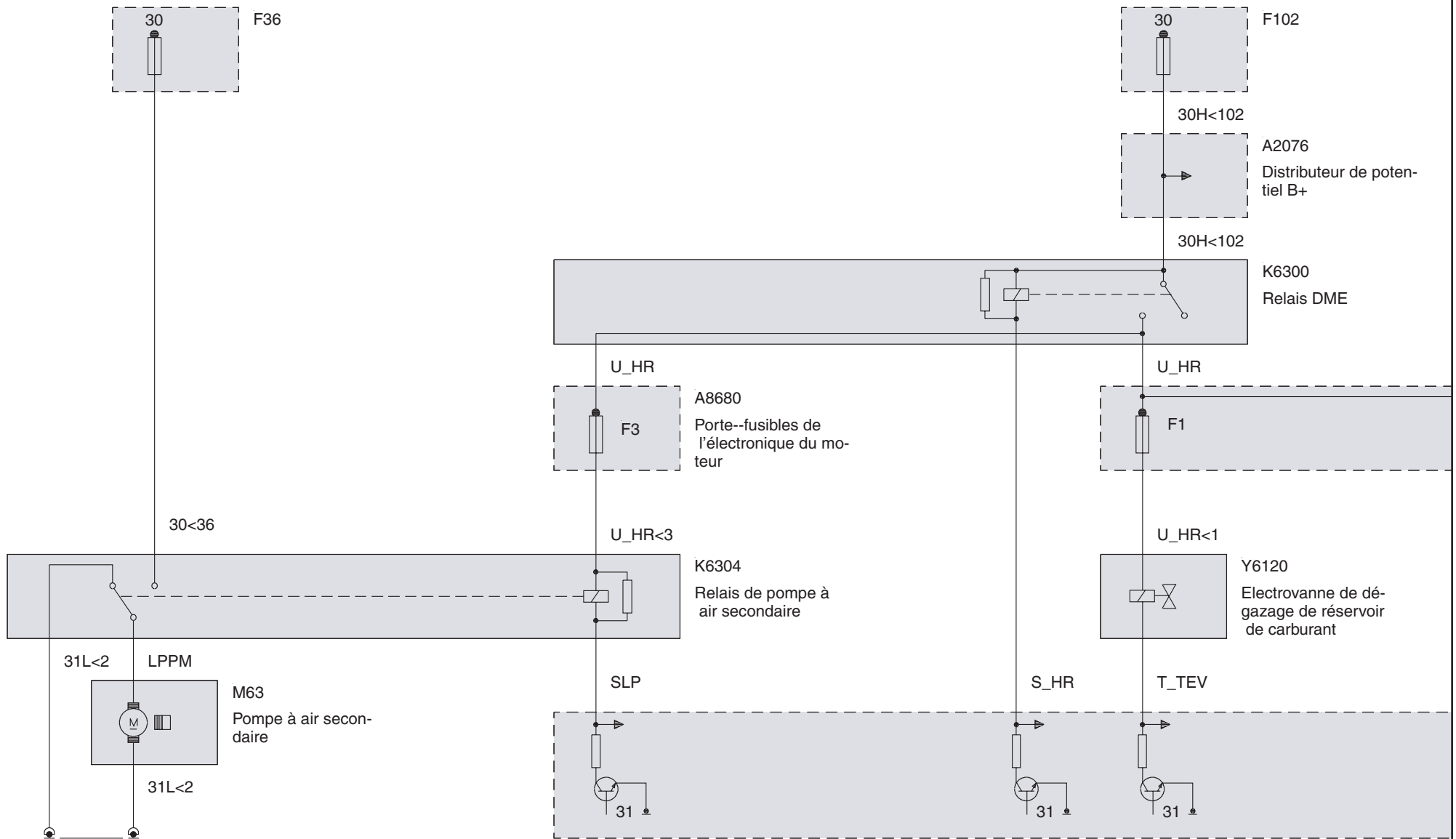

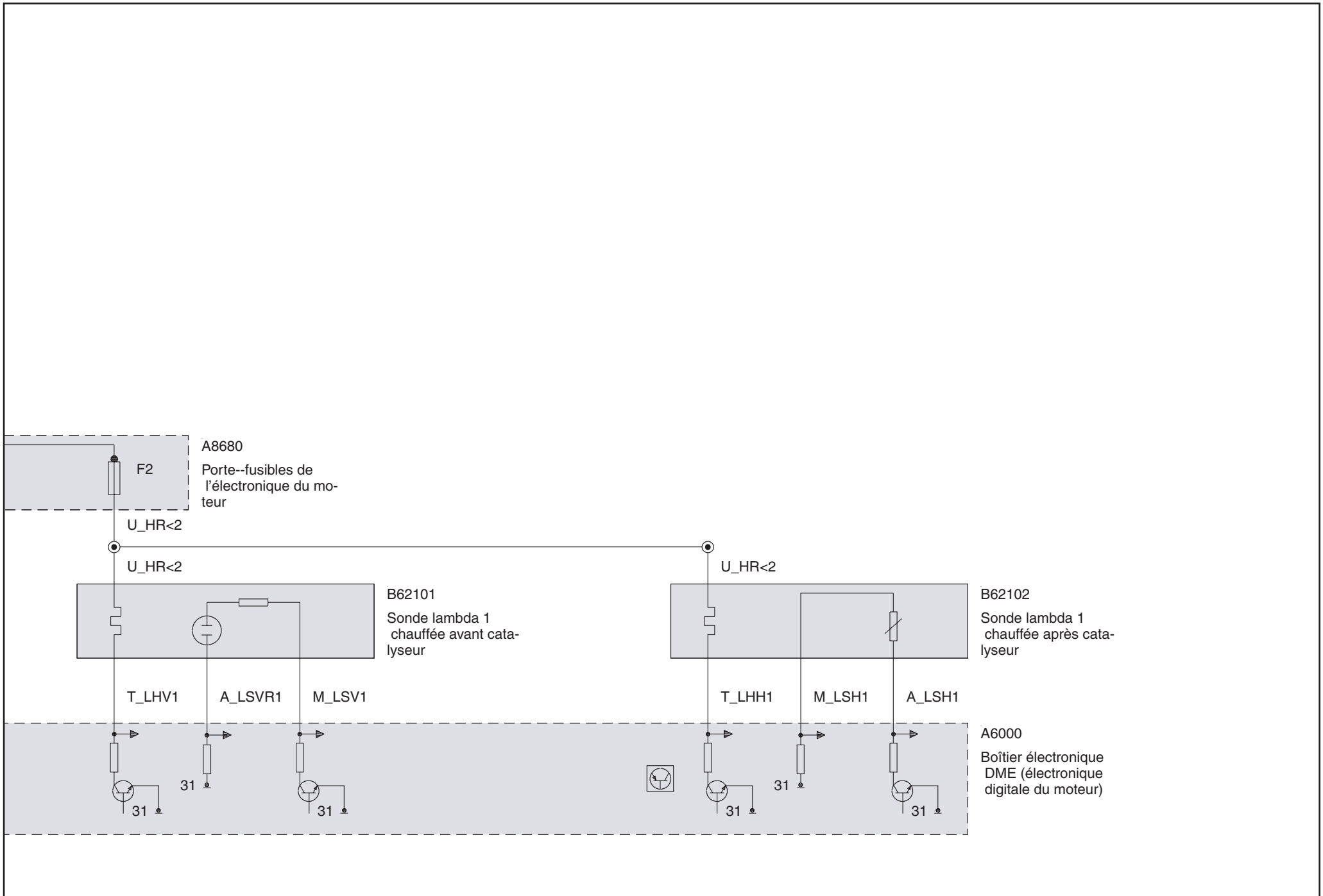



Commande du moteur, signaux/signaux auxiliaires (Moteur N45)

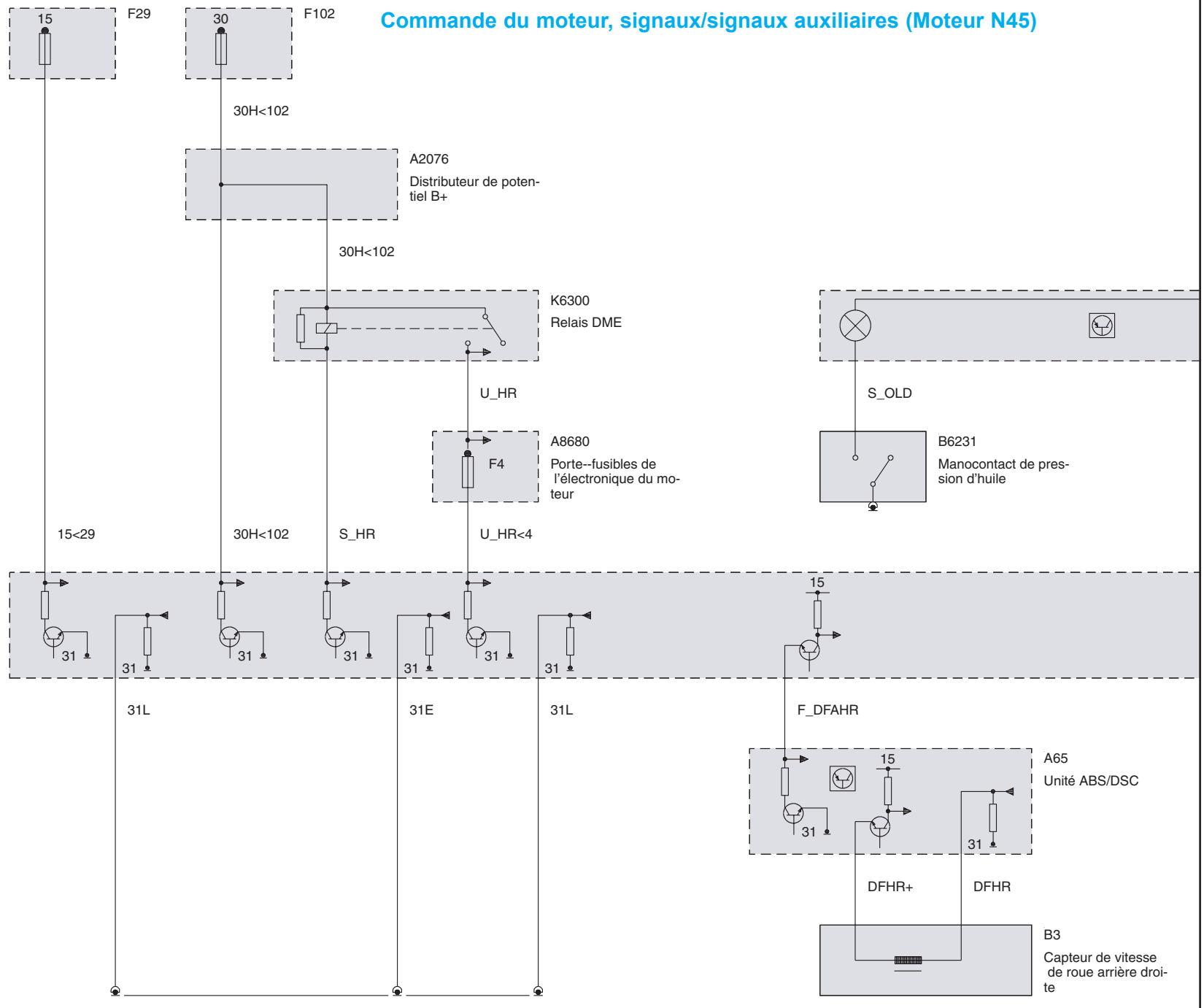

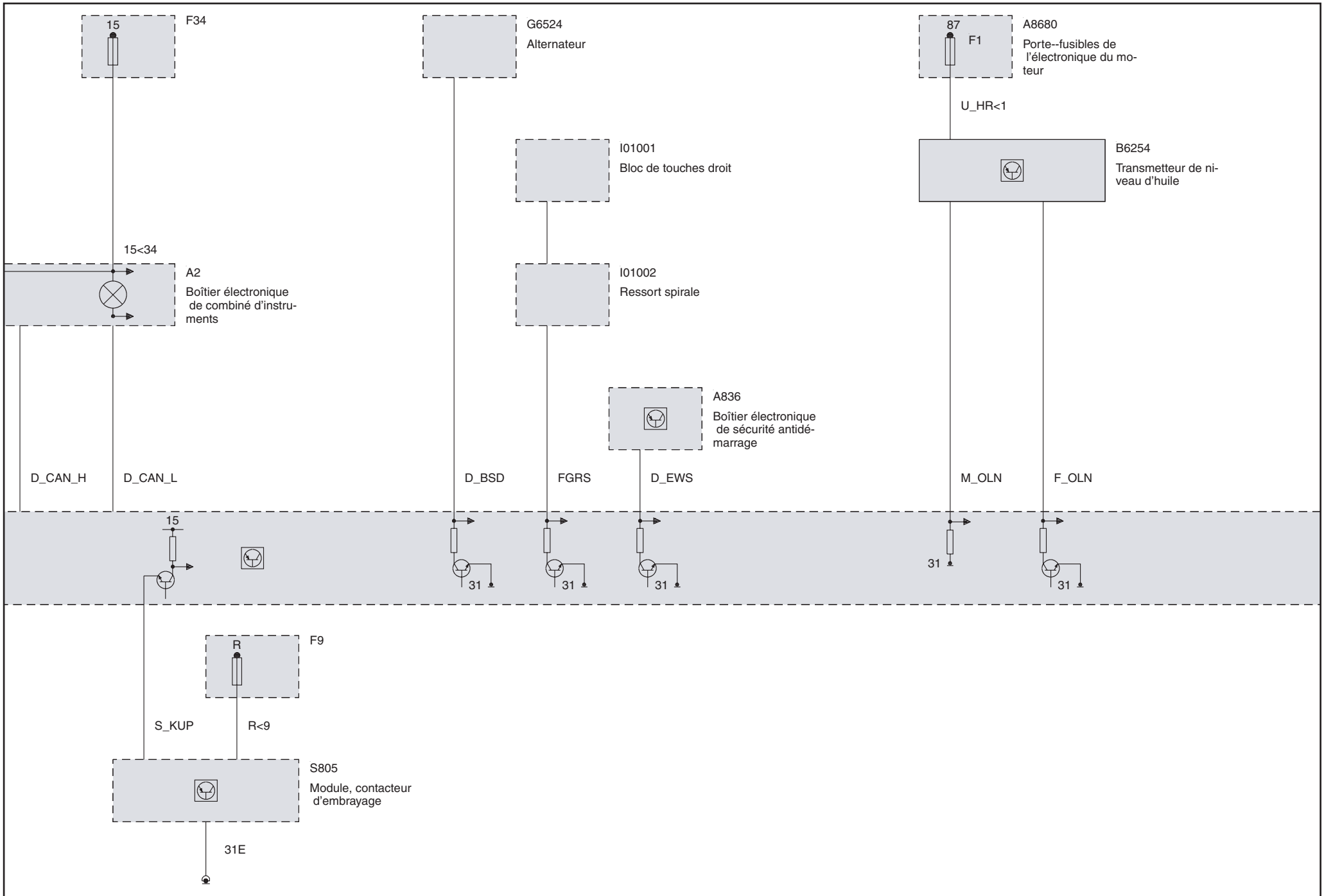

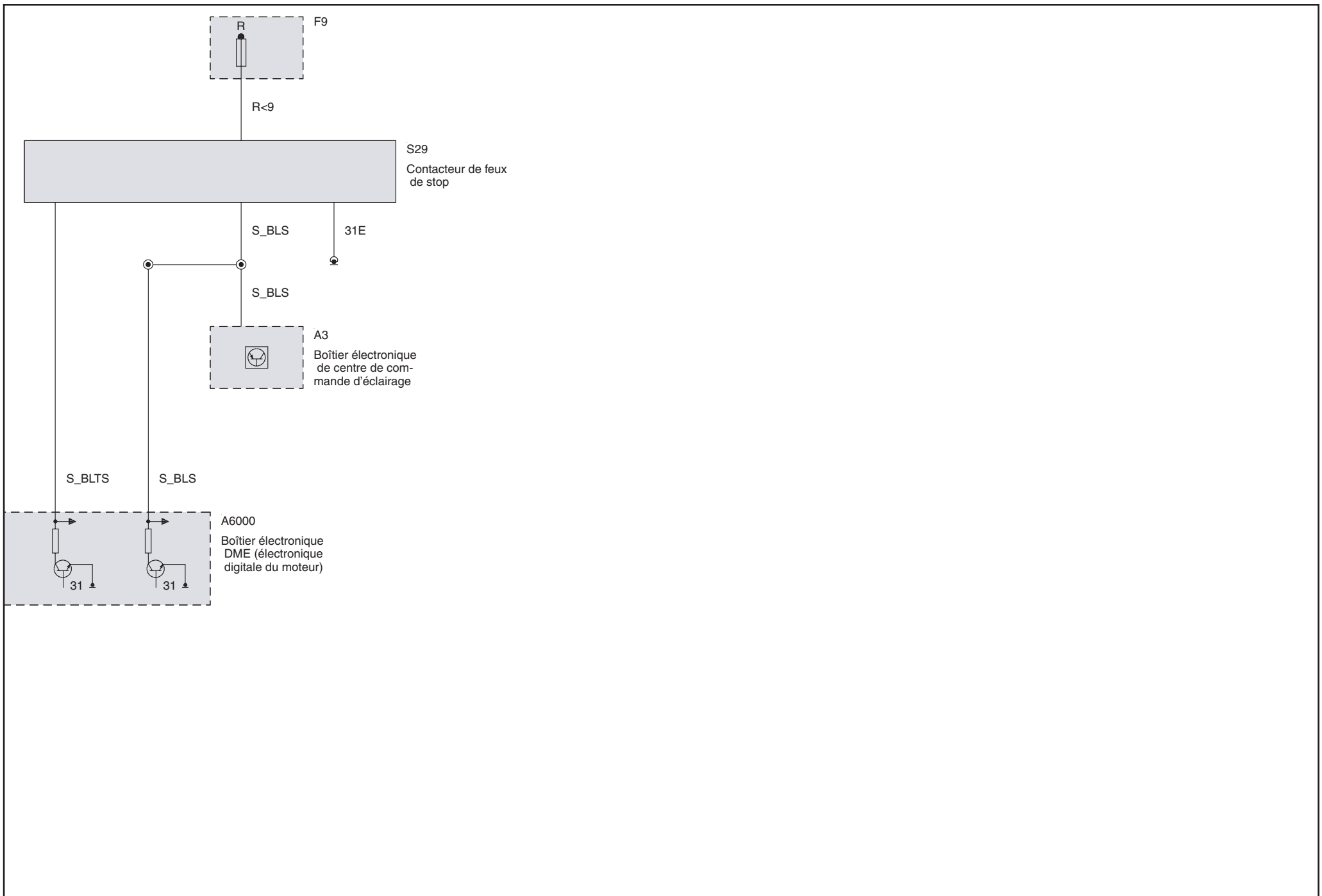

Injecteurs

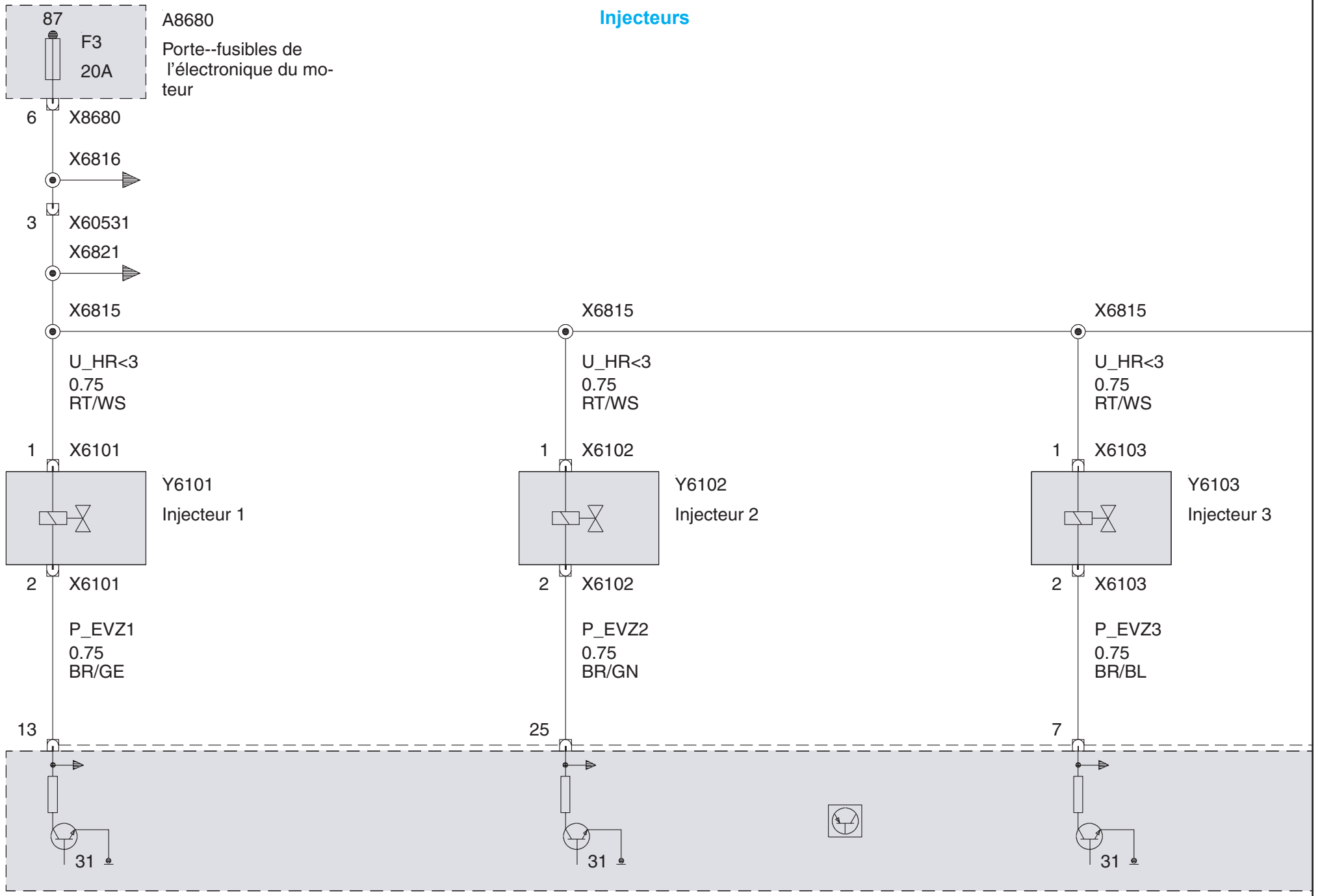

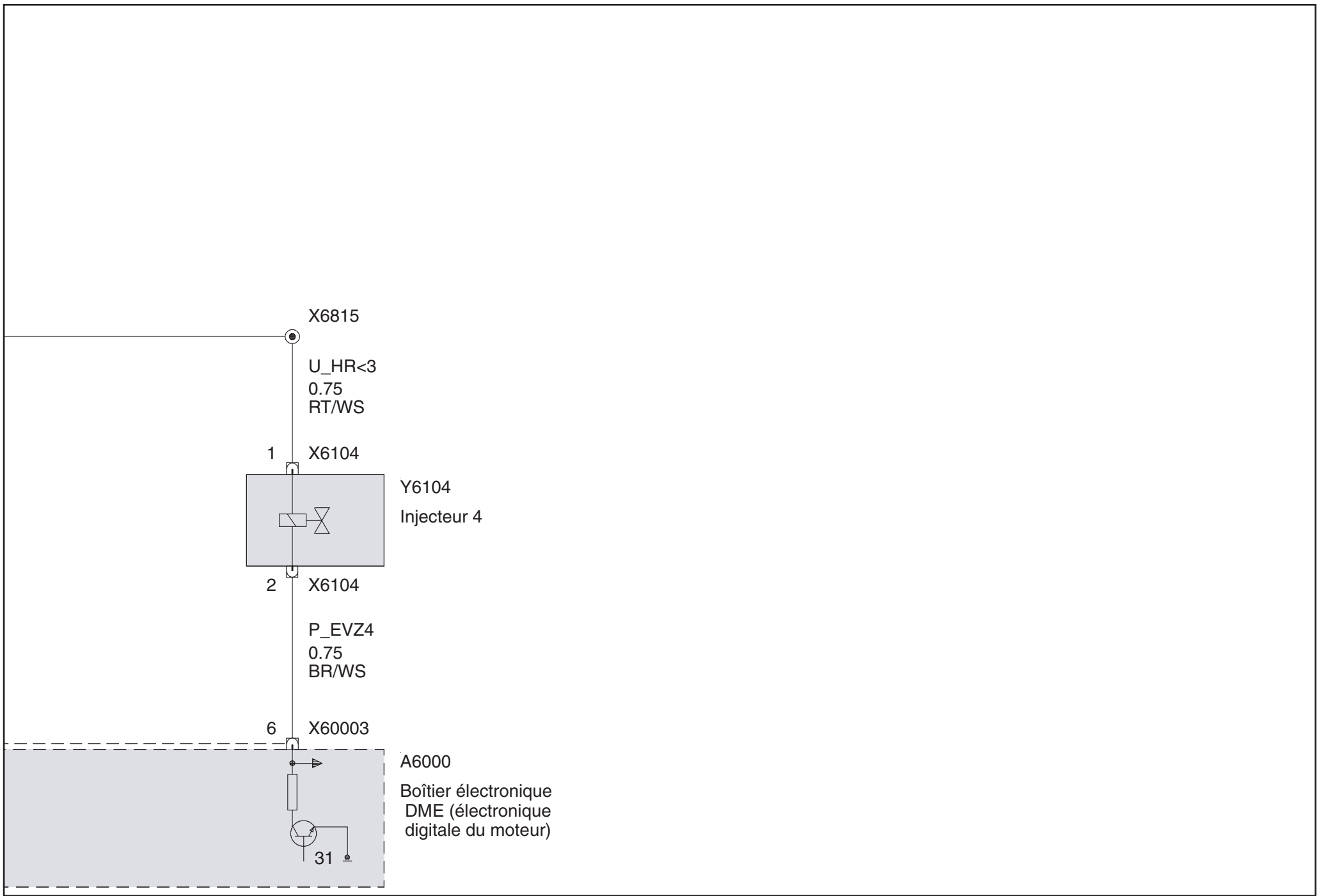

Pompe à carburant

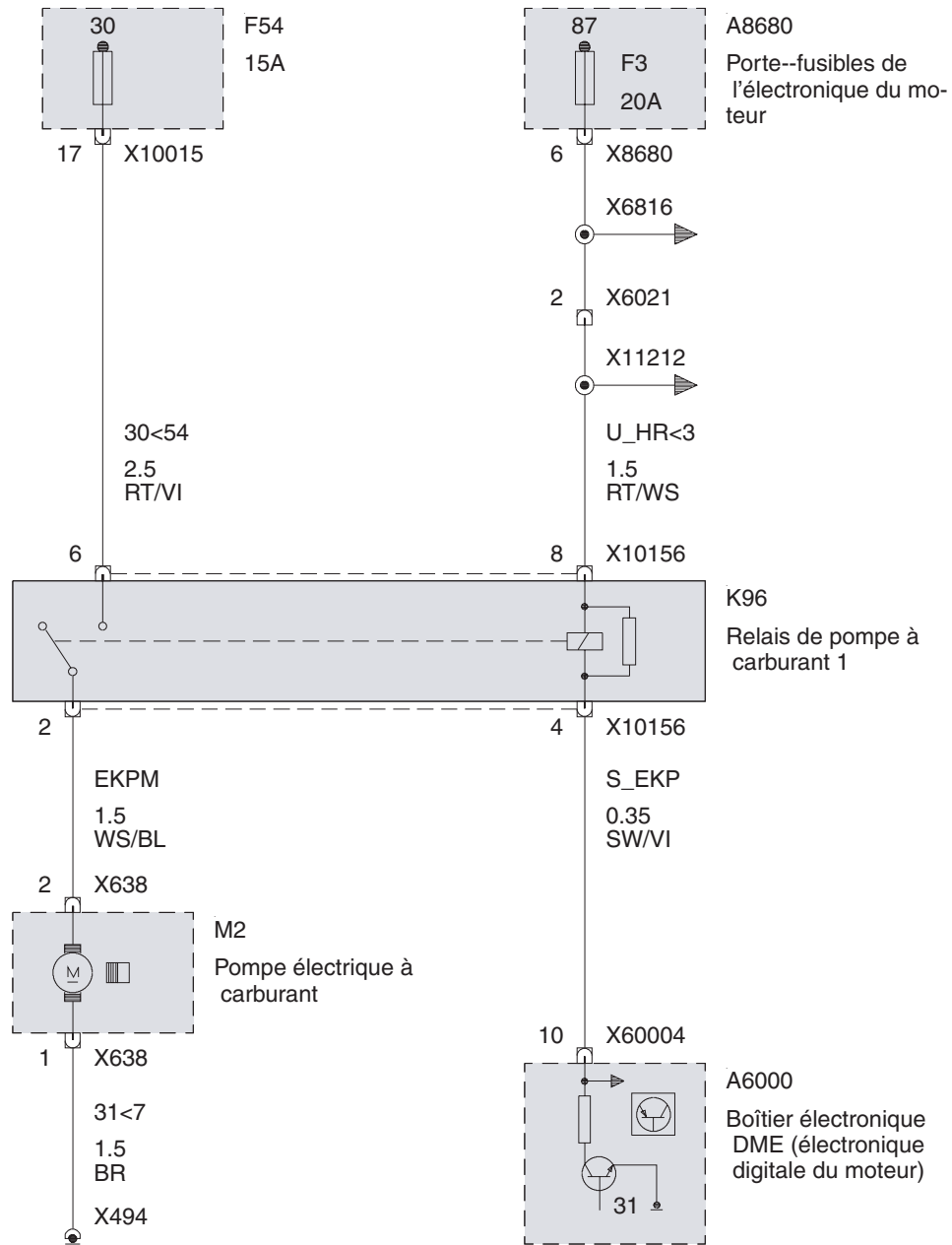

Allumage

Bobines d'allumage (sauf Moteur N45)

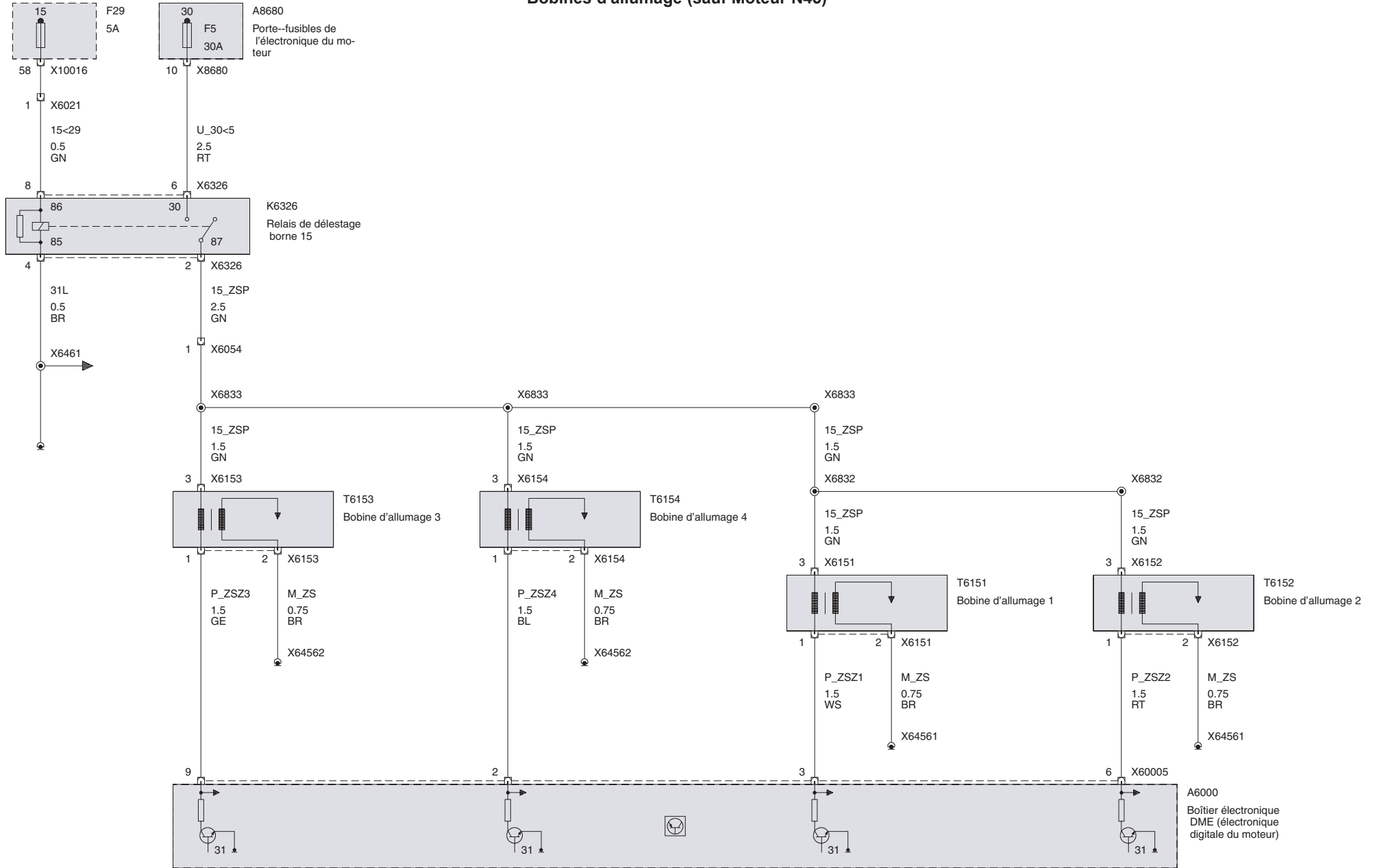

**Bobines d'allumage (Moteur N45)**

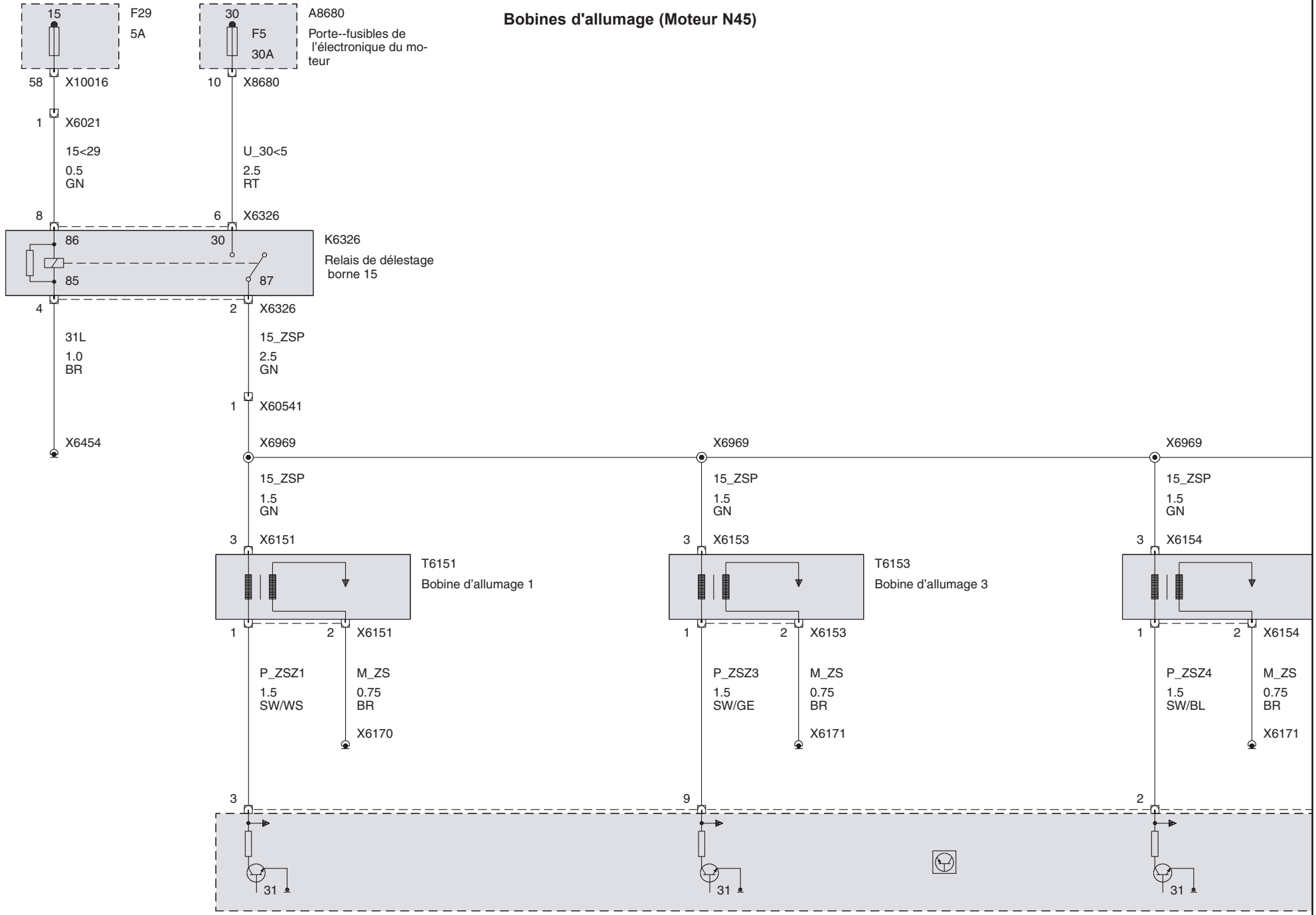



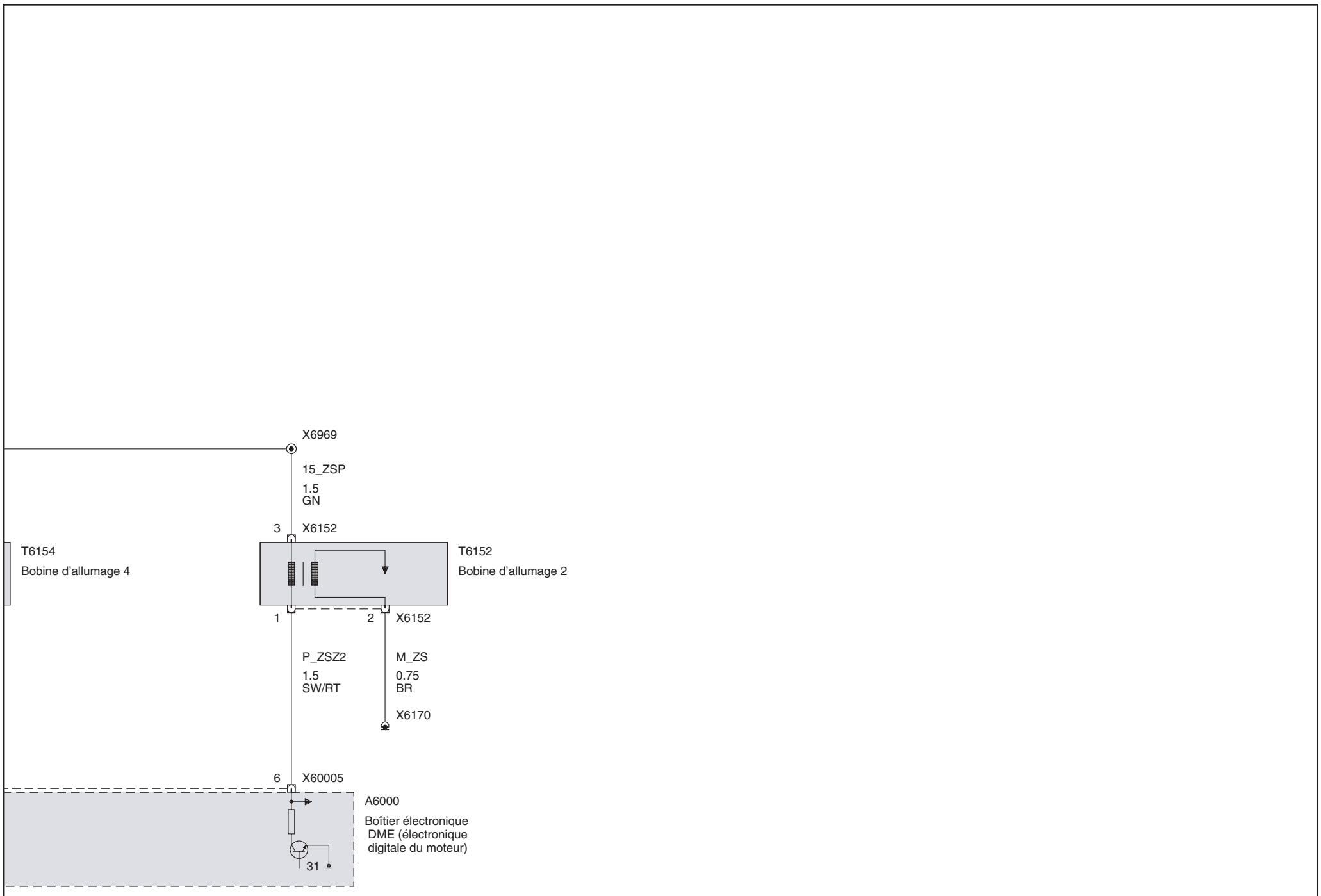

Régulation anti-cliquetis

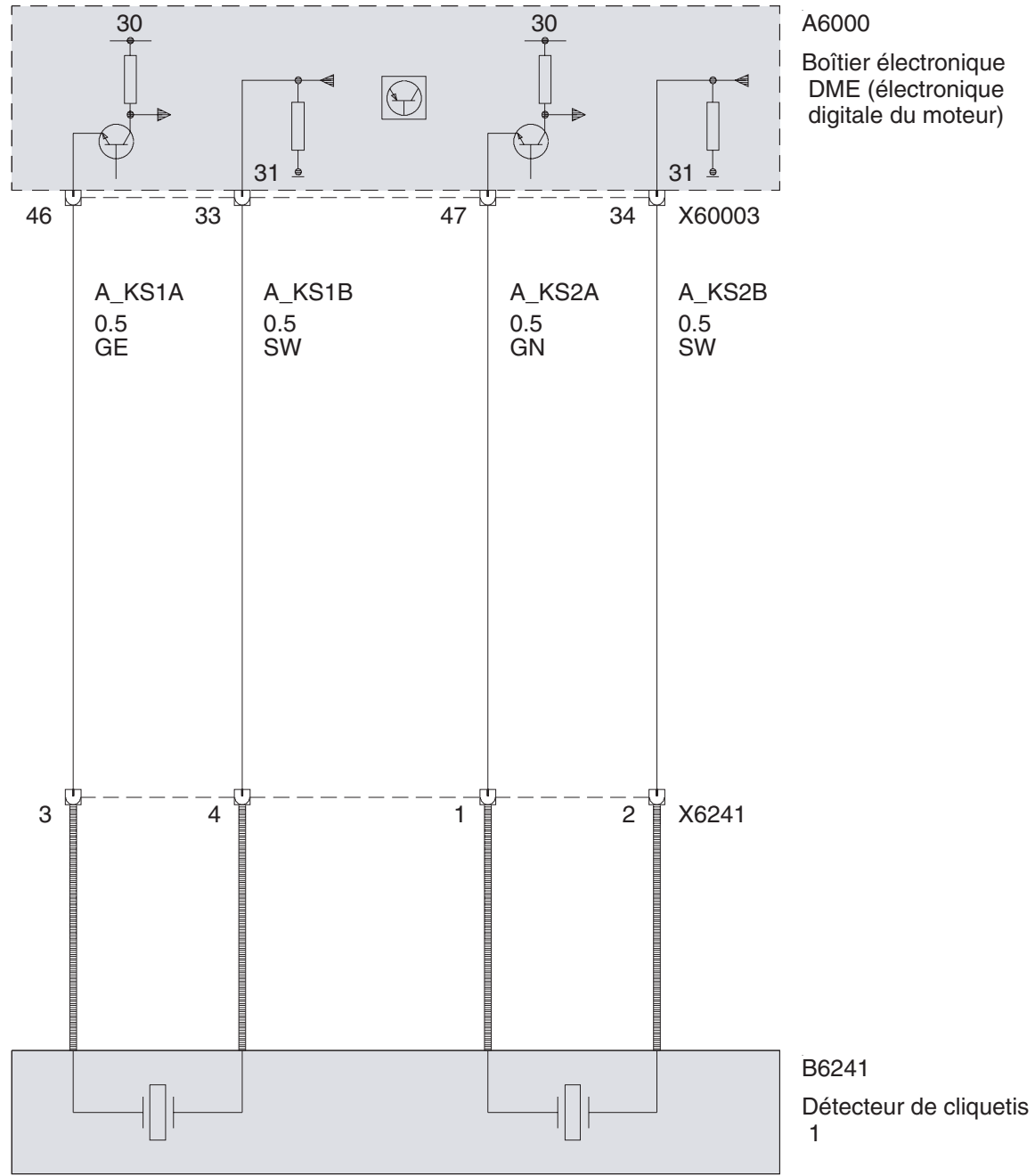

Régulation Lambda (Moteur N42 avec 4 Sondes Lambda)  
Sondes lambda avant catalyseur

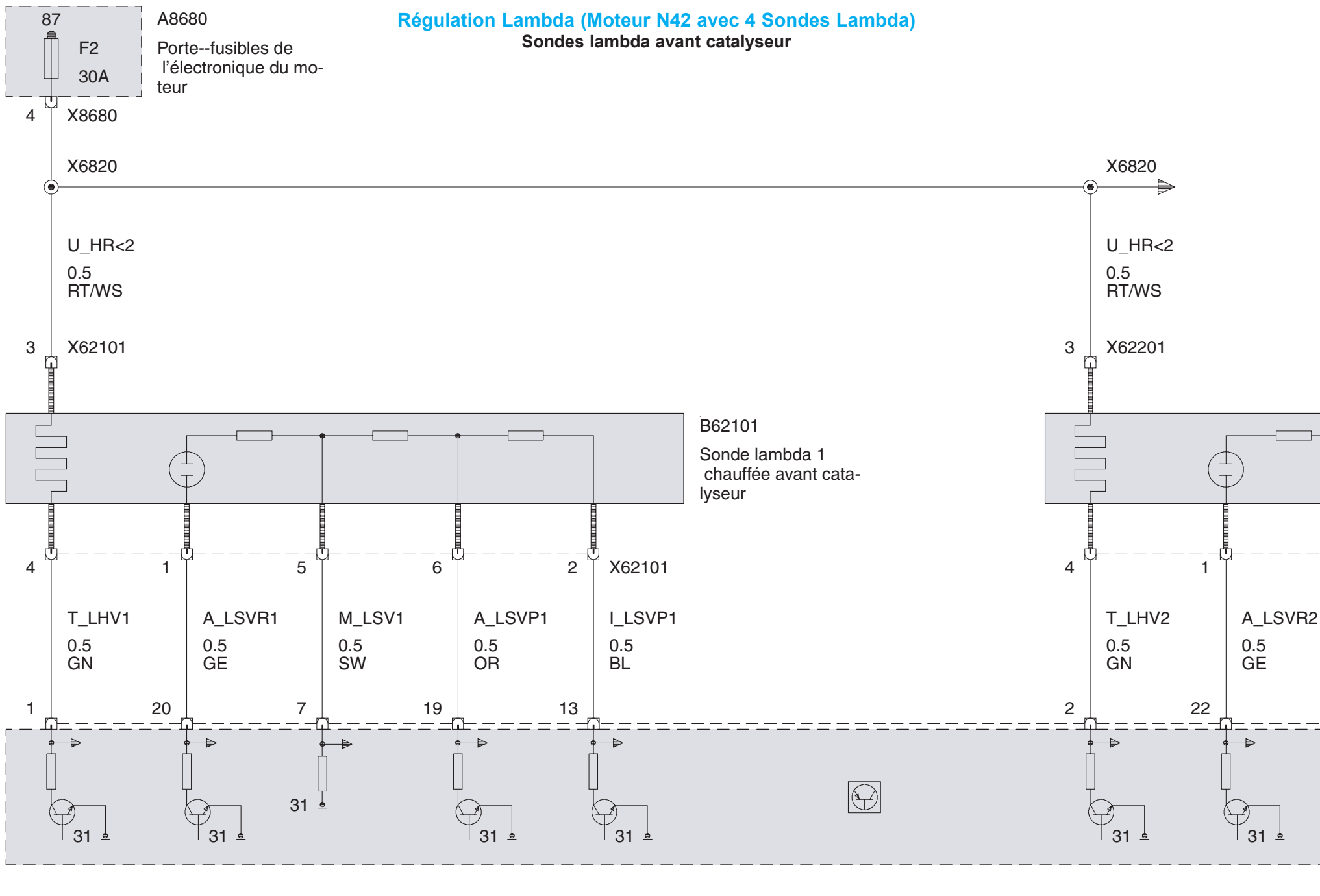

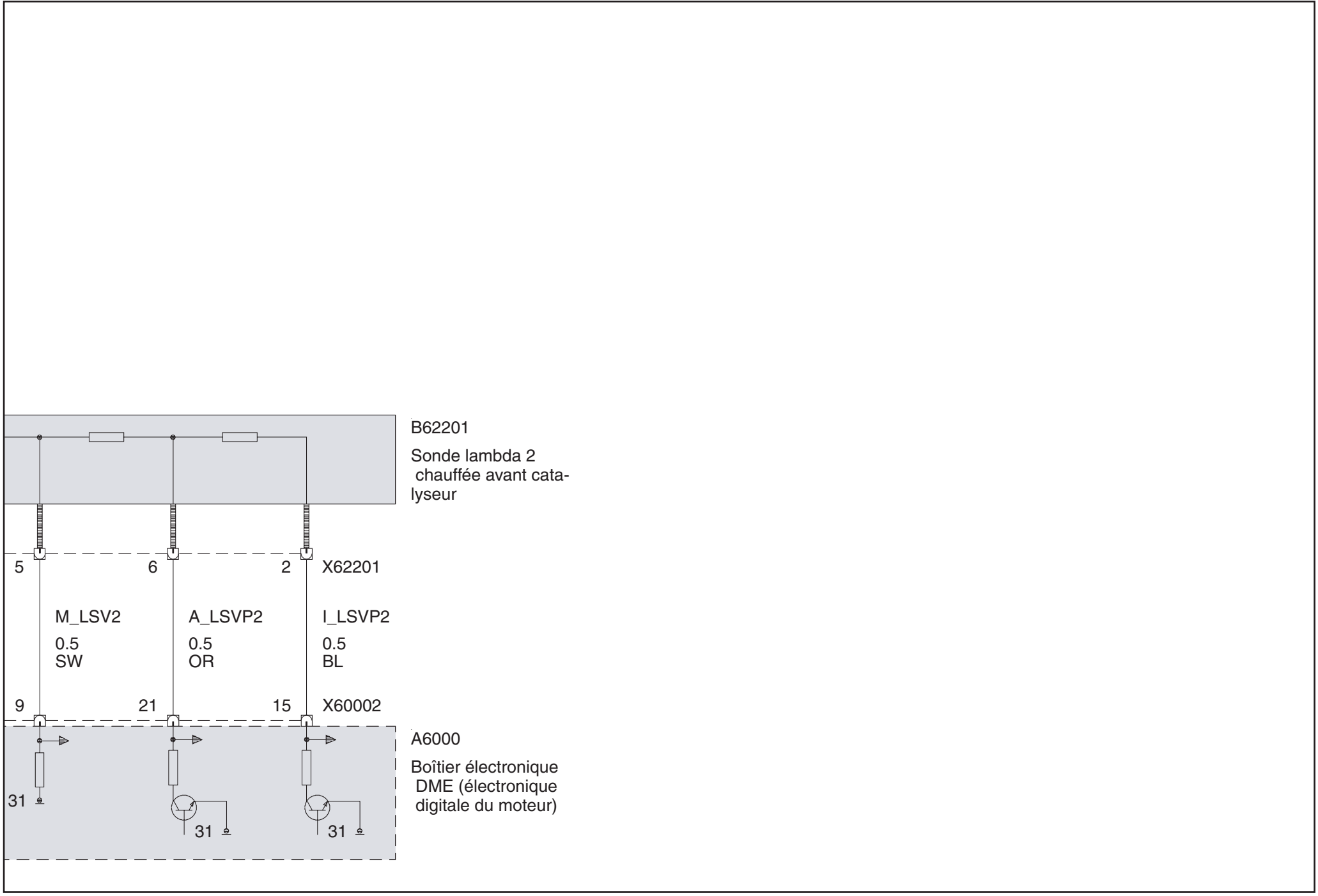

B62201  
Sonde lambda 2  
chauffée avant cata-  
lyseur

A6000  
Boîtier électronique  
DME (électronique  
digitale du moteur)

Sondes lambda après catalyseur

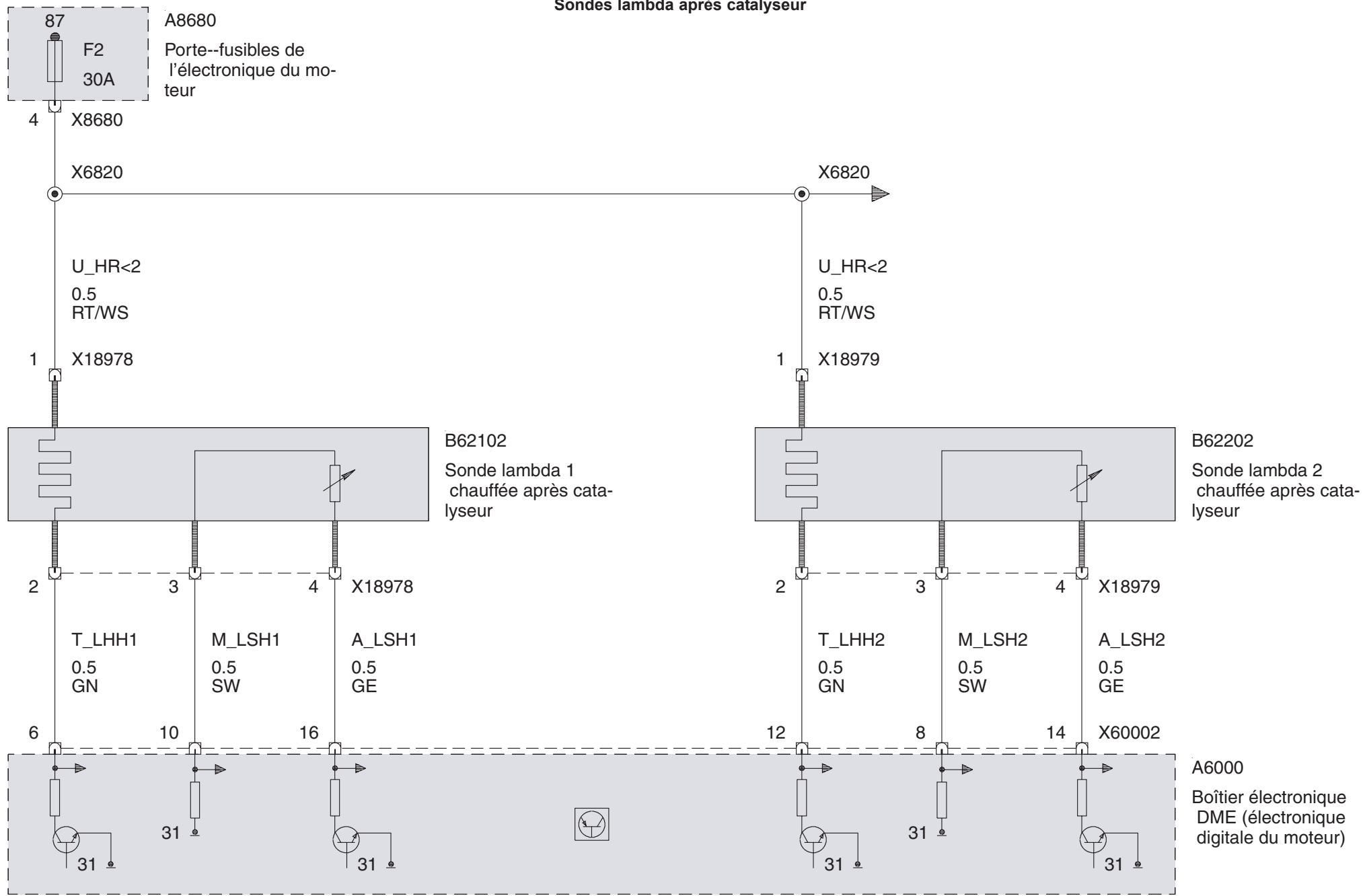

Régulation Lambda (Moteur N42 à partir de 2002\_03 avec 2 Sondes Lambda)

Sonde Lambda avant catalyseur

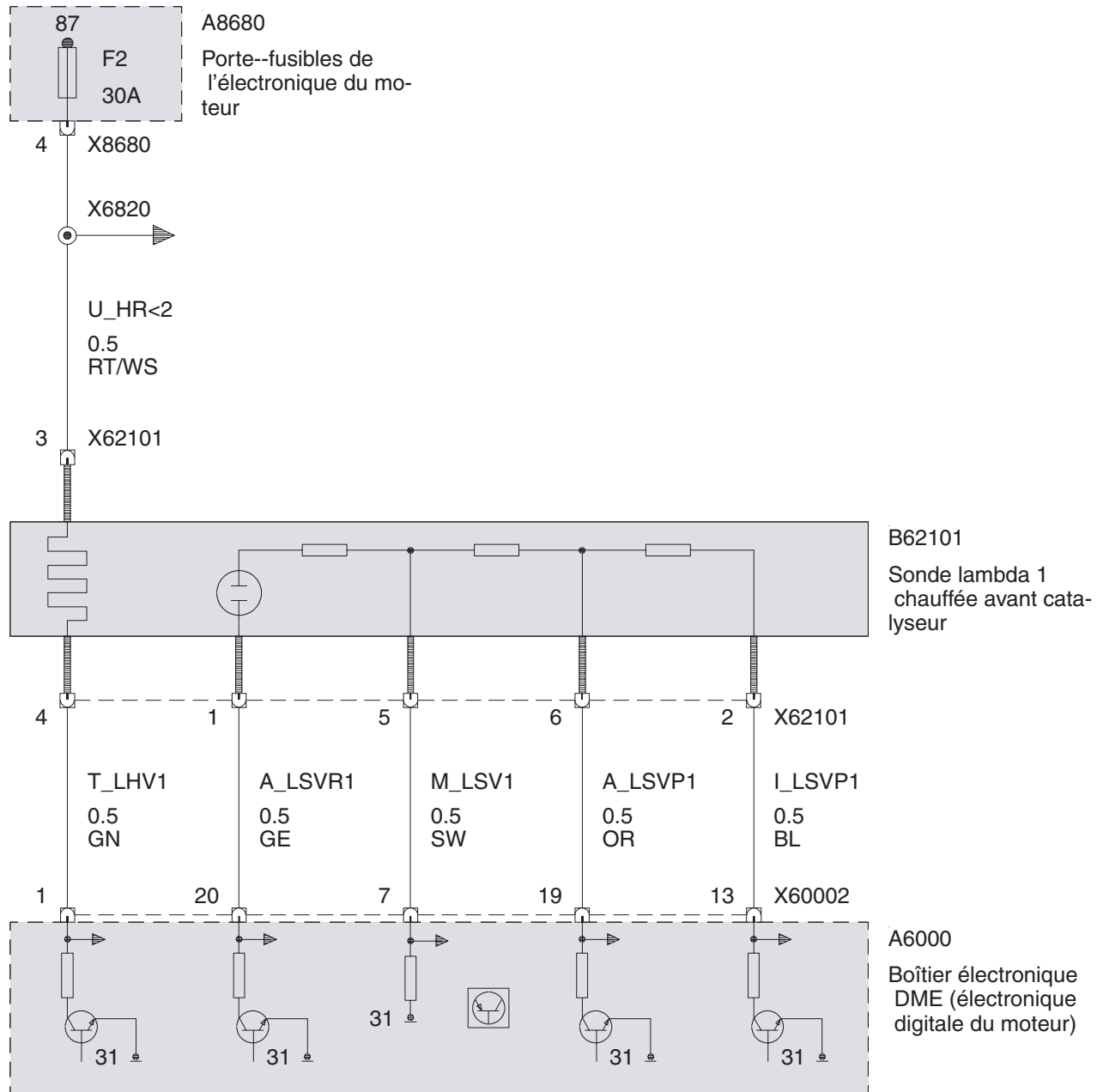

Sonde lambda après catalyseur

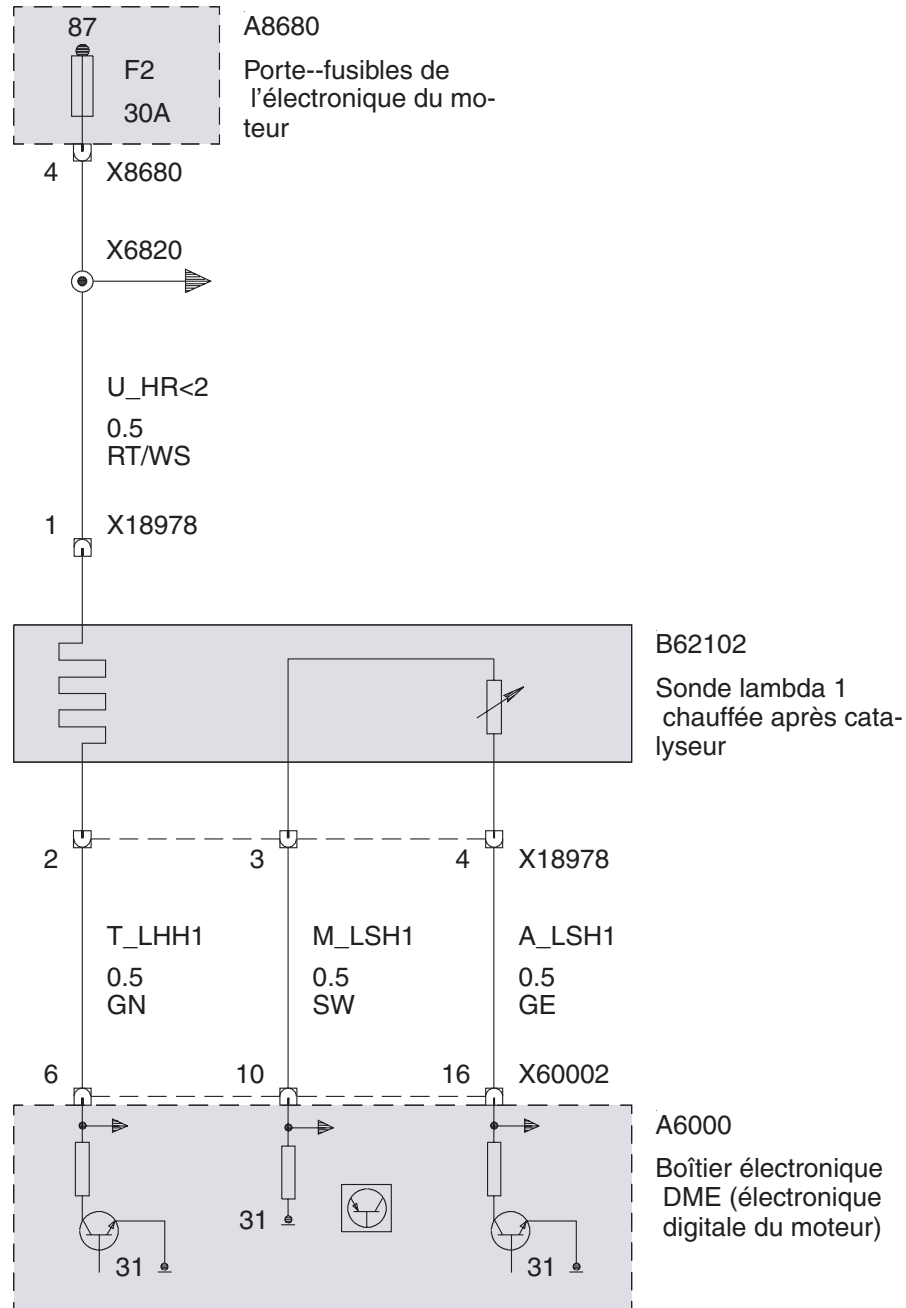

## Régulation Lambda (Moteur N40 ou Moteur N45)

Sonde Lambda avant catalyseur

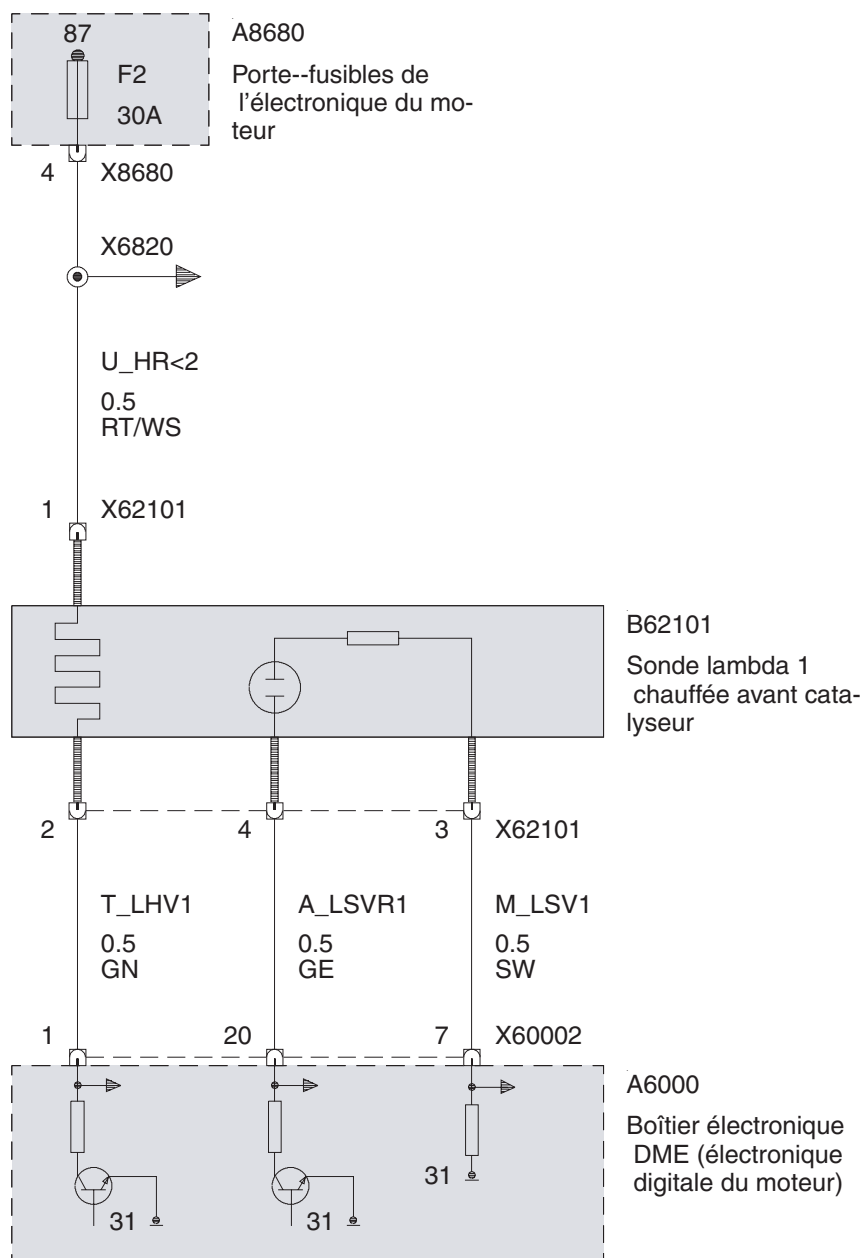



Sonde lambda après catalyseur

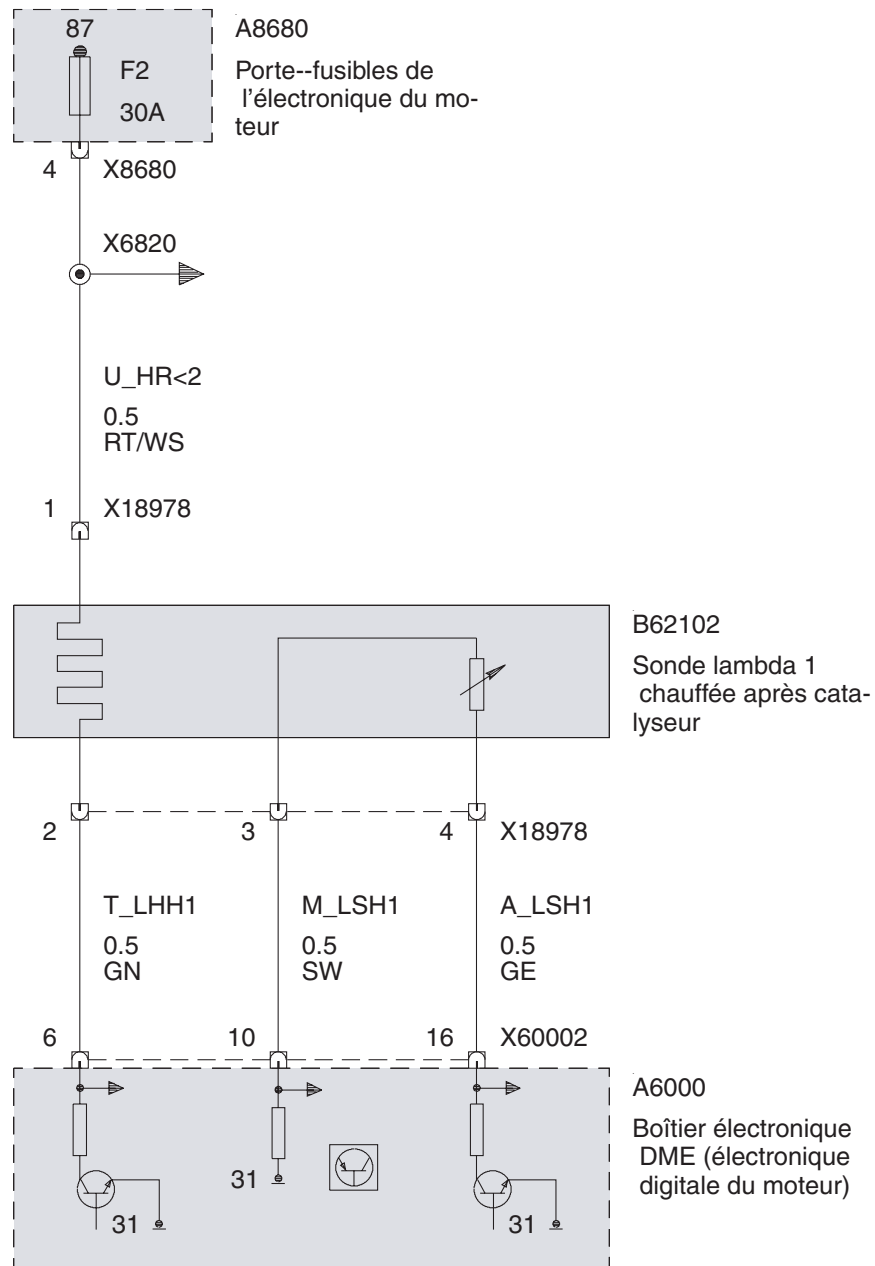

### Alimentation en air Débitmètre massique à film chaud (Moteur N42)

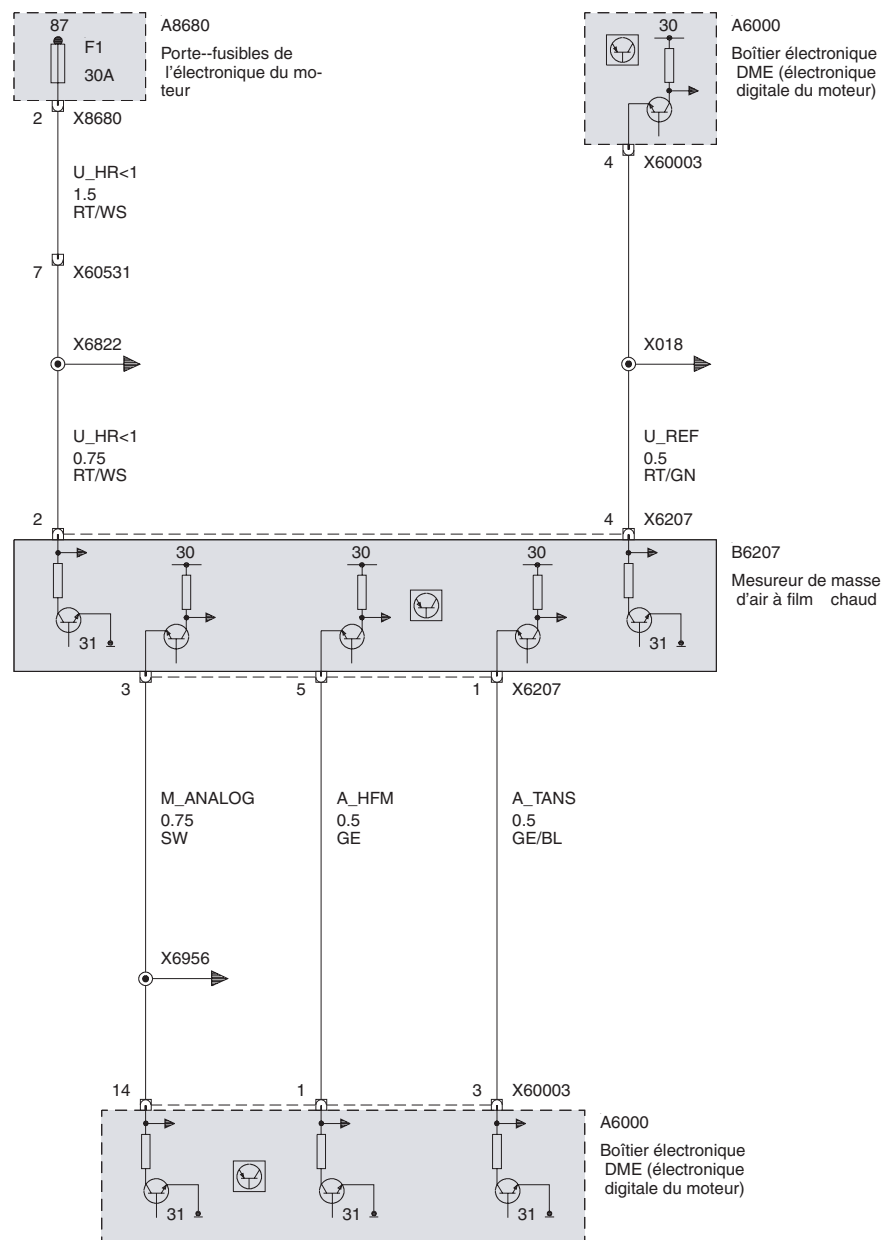

Débitmètre massique à film chaud (Moteur N40)

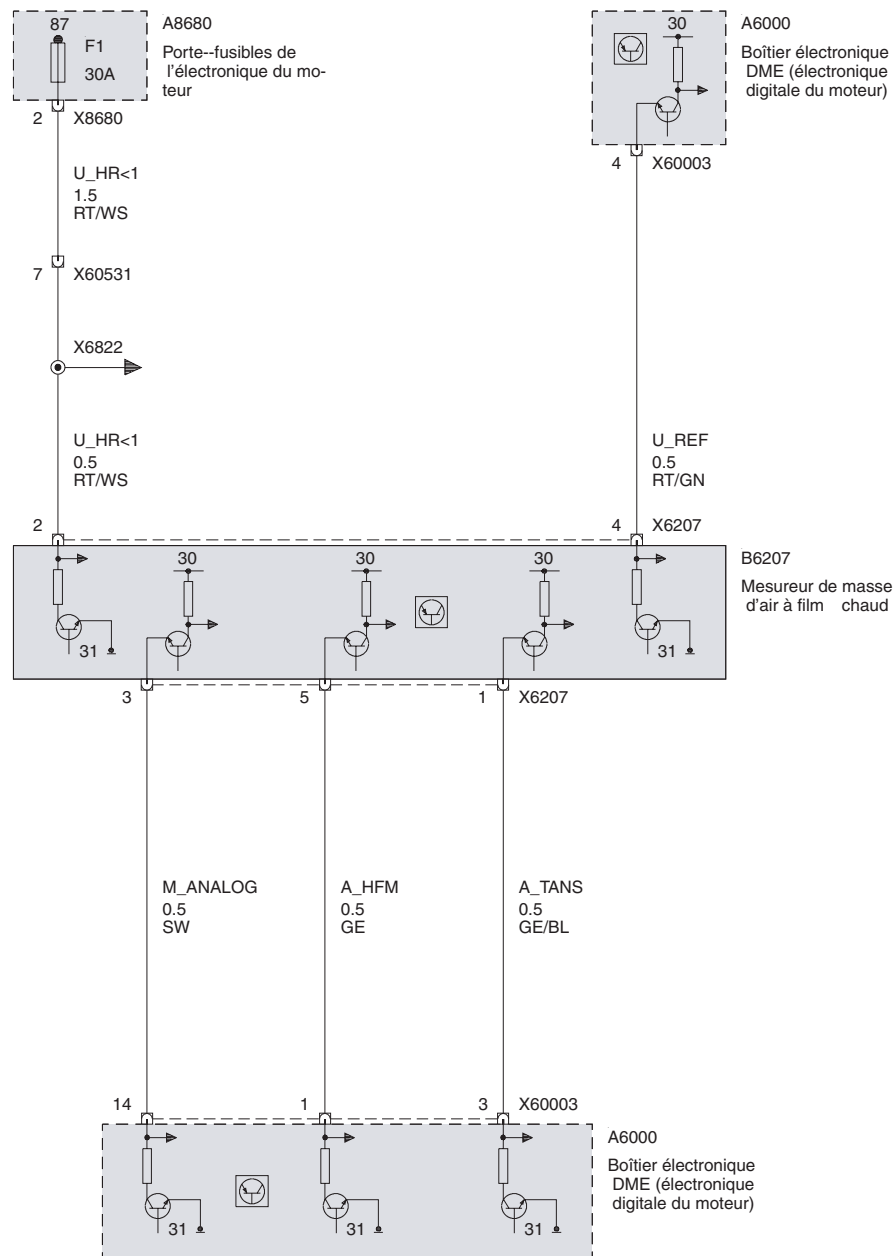

Débitmètre massique à film chaud (Moteur N45)

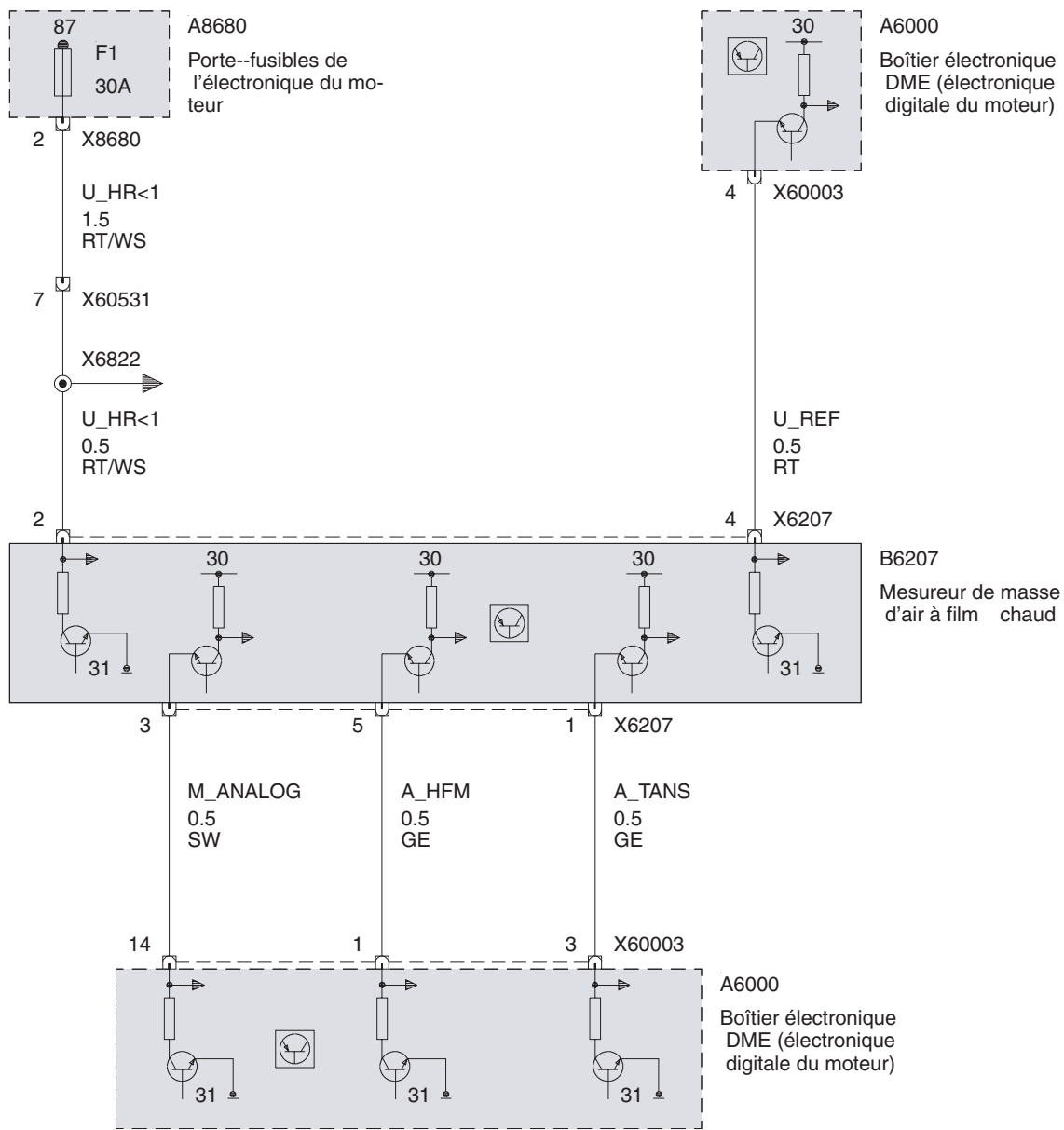

Actionneur de papillon à moteur électrique (sans Moteur N45)

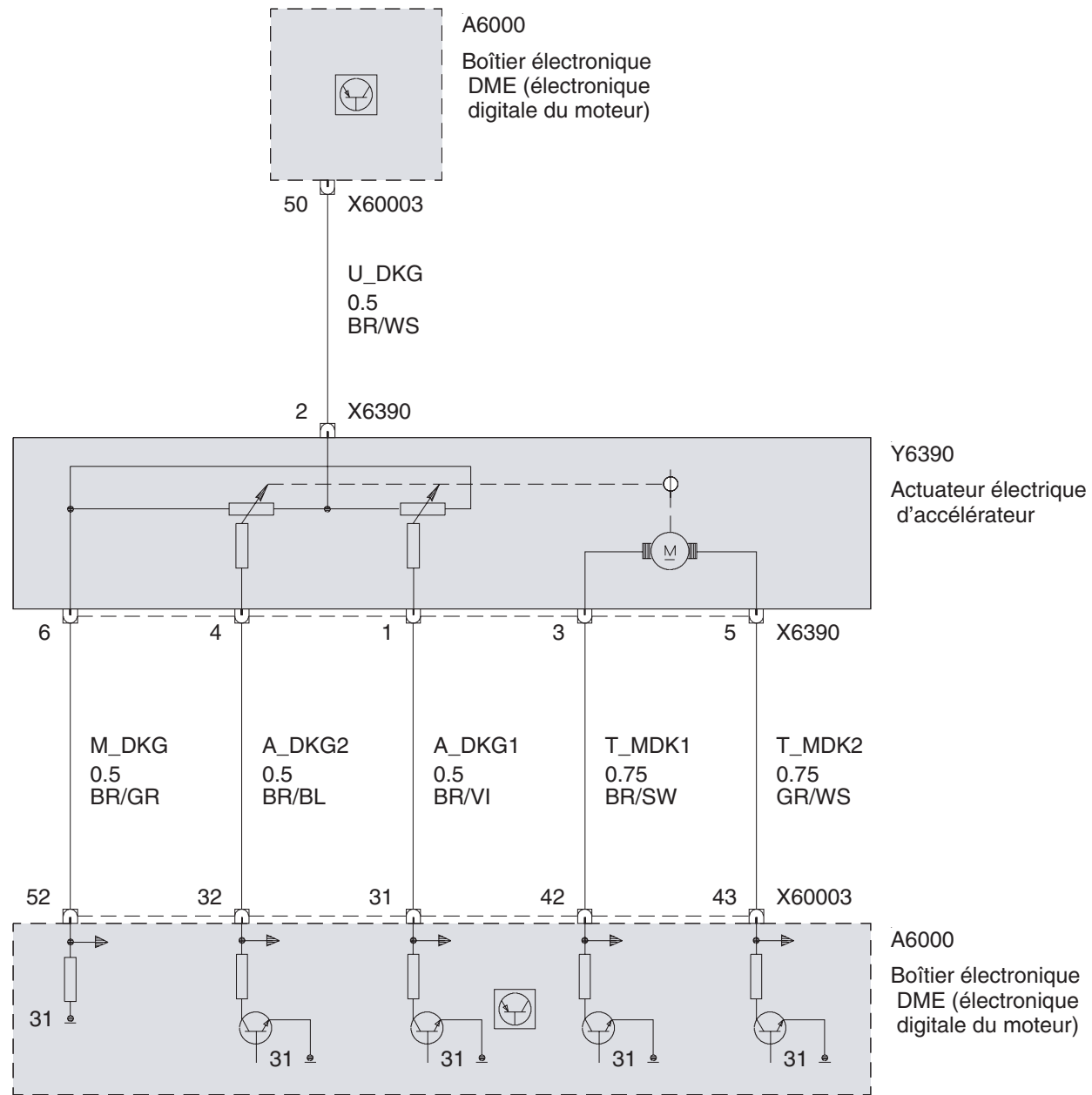

Actionneur de papillon à moteur électrique (Moteur N45)

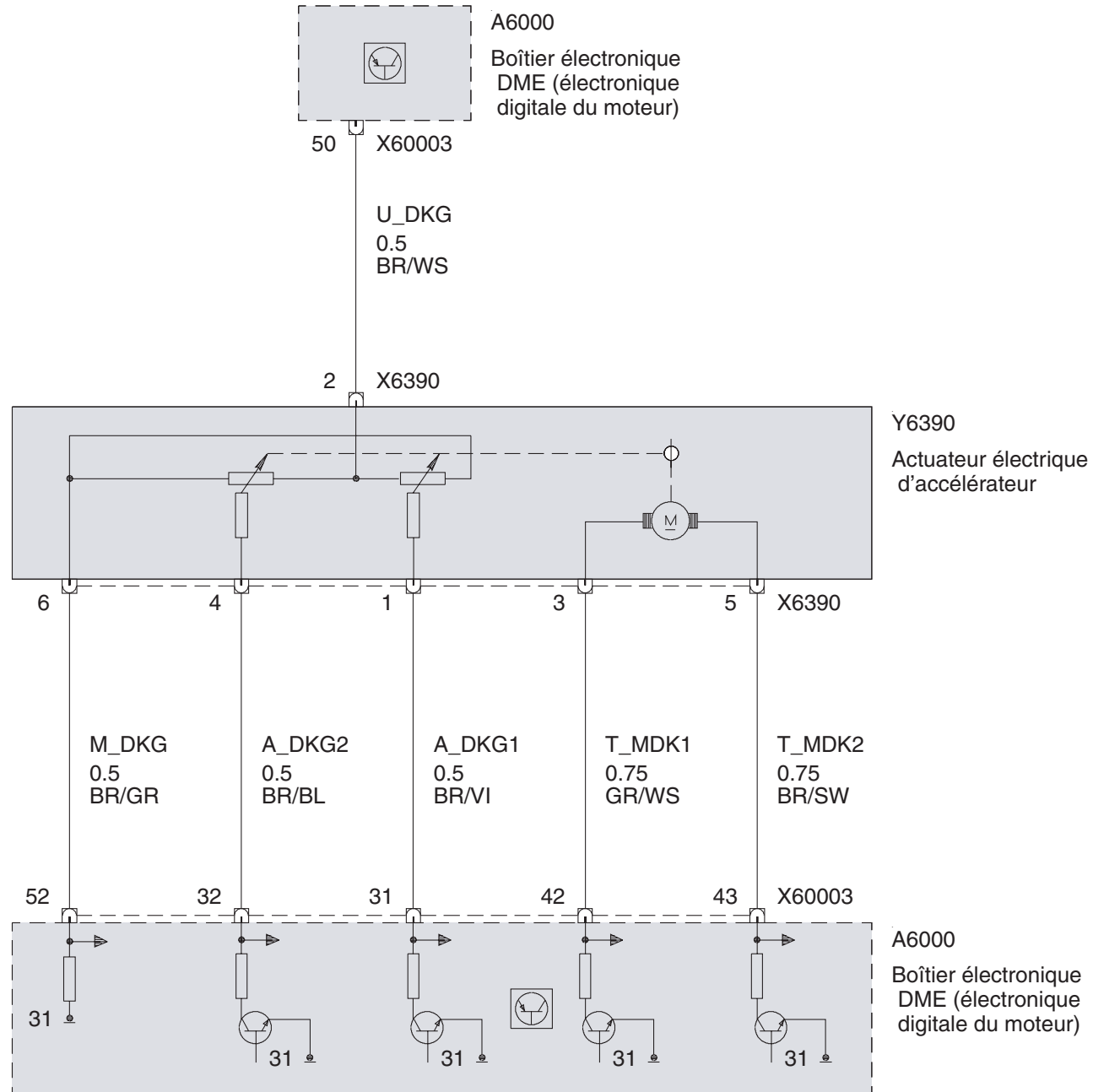

## Electrovanne pompe autoaspirante (Moteur N40 ou Moteur N45)

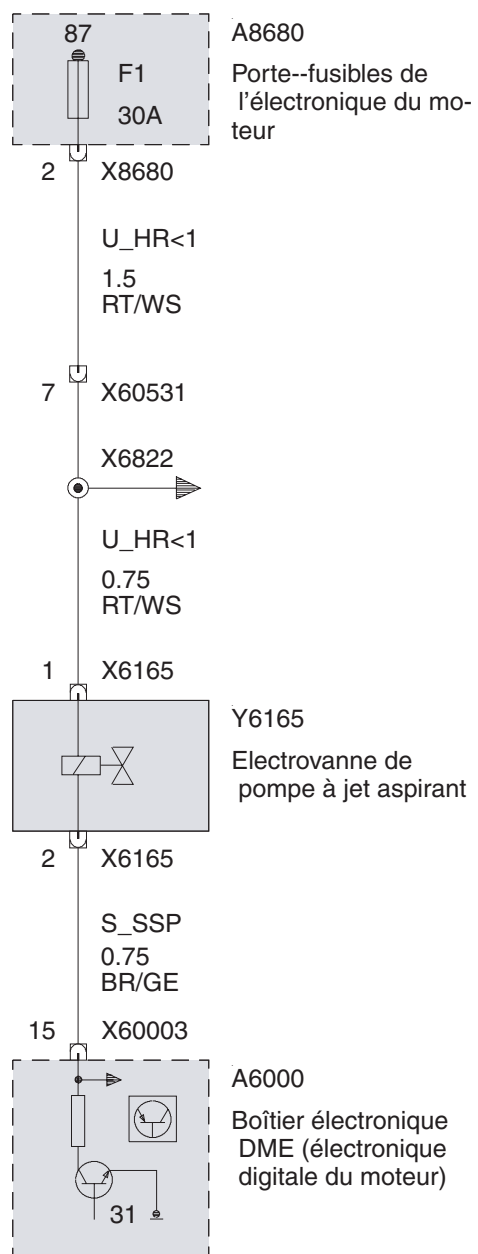

Capteur de pression de tubulure d'admission (Moteur N42)

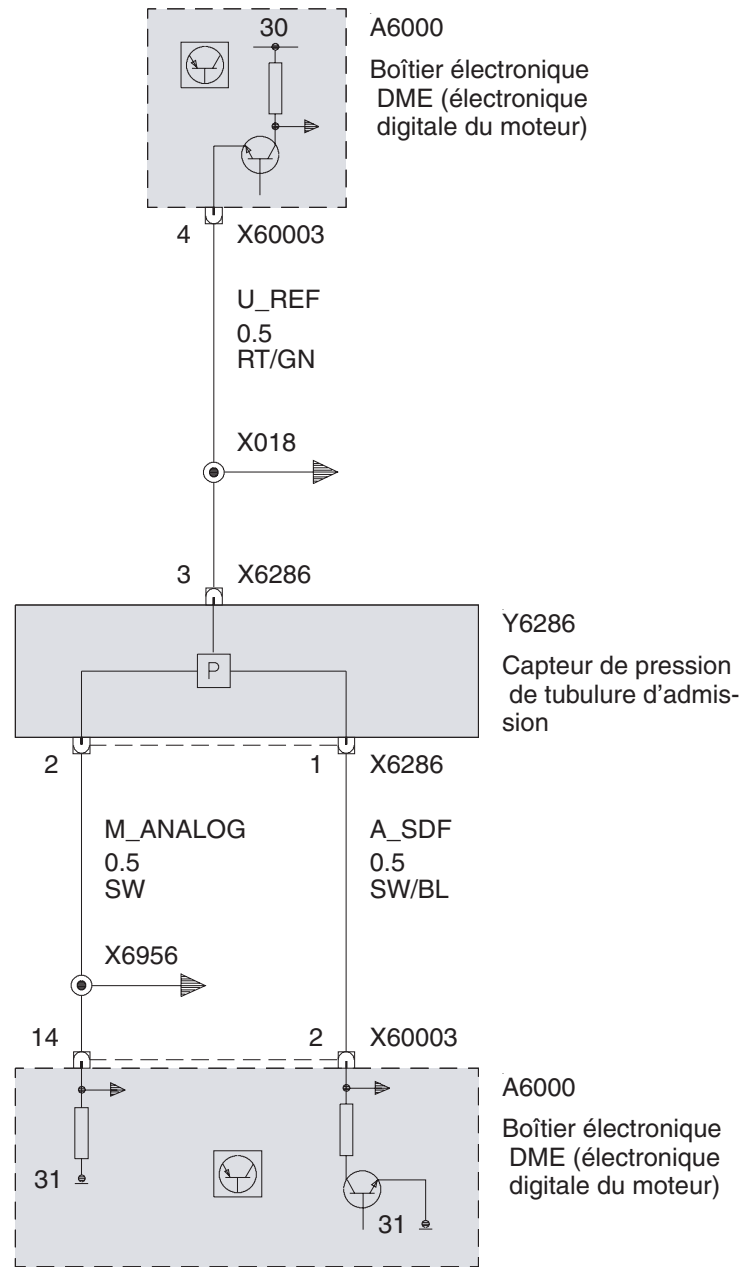



Système variable d'admission (Moteur N42)

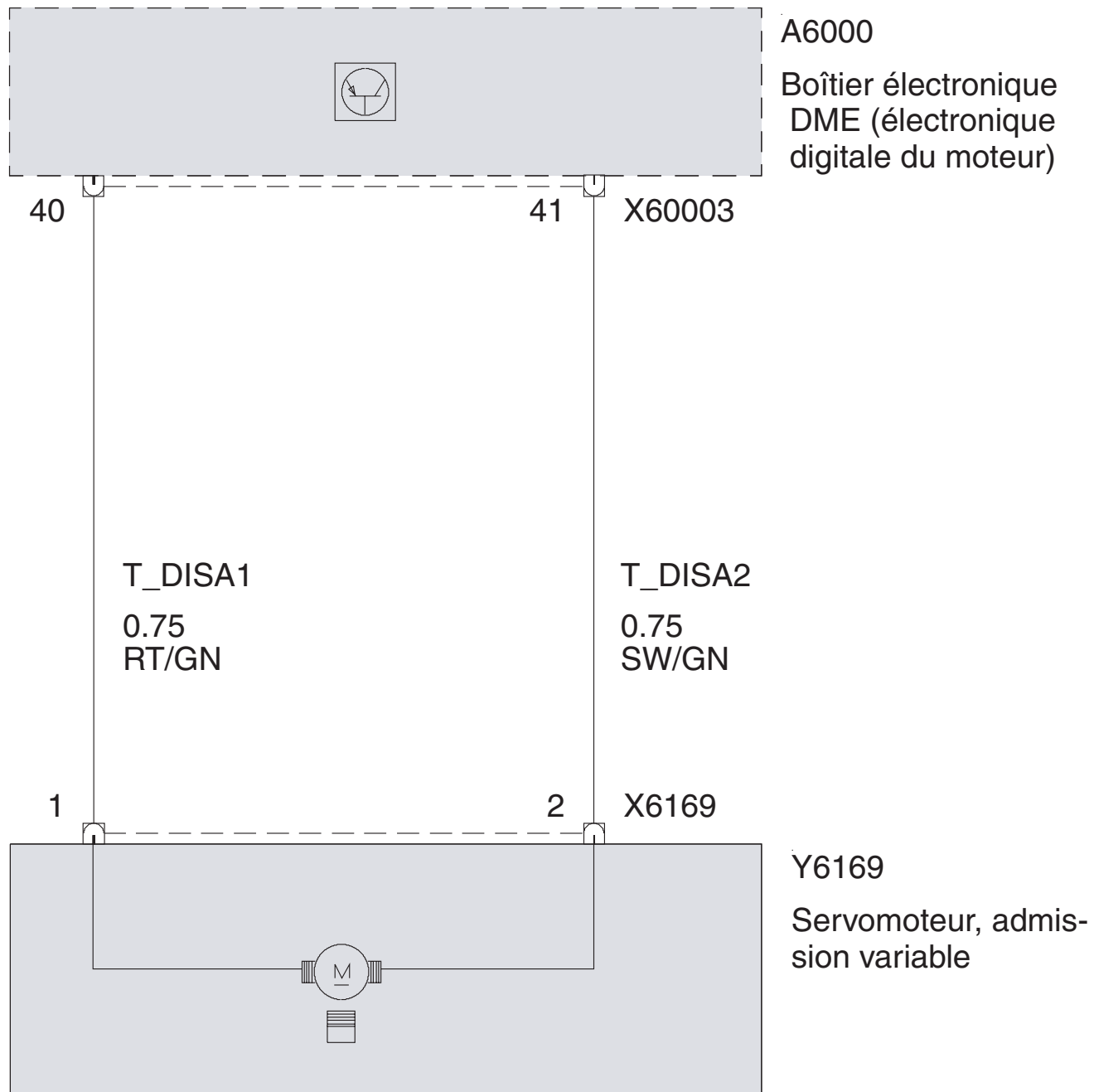

## Capteur de vilebrequin

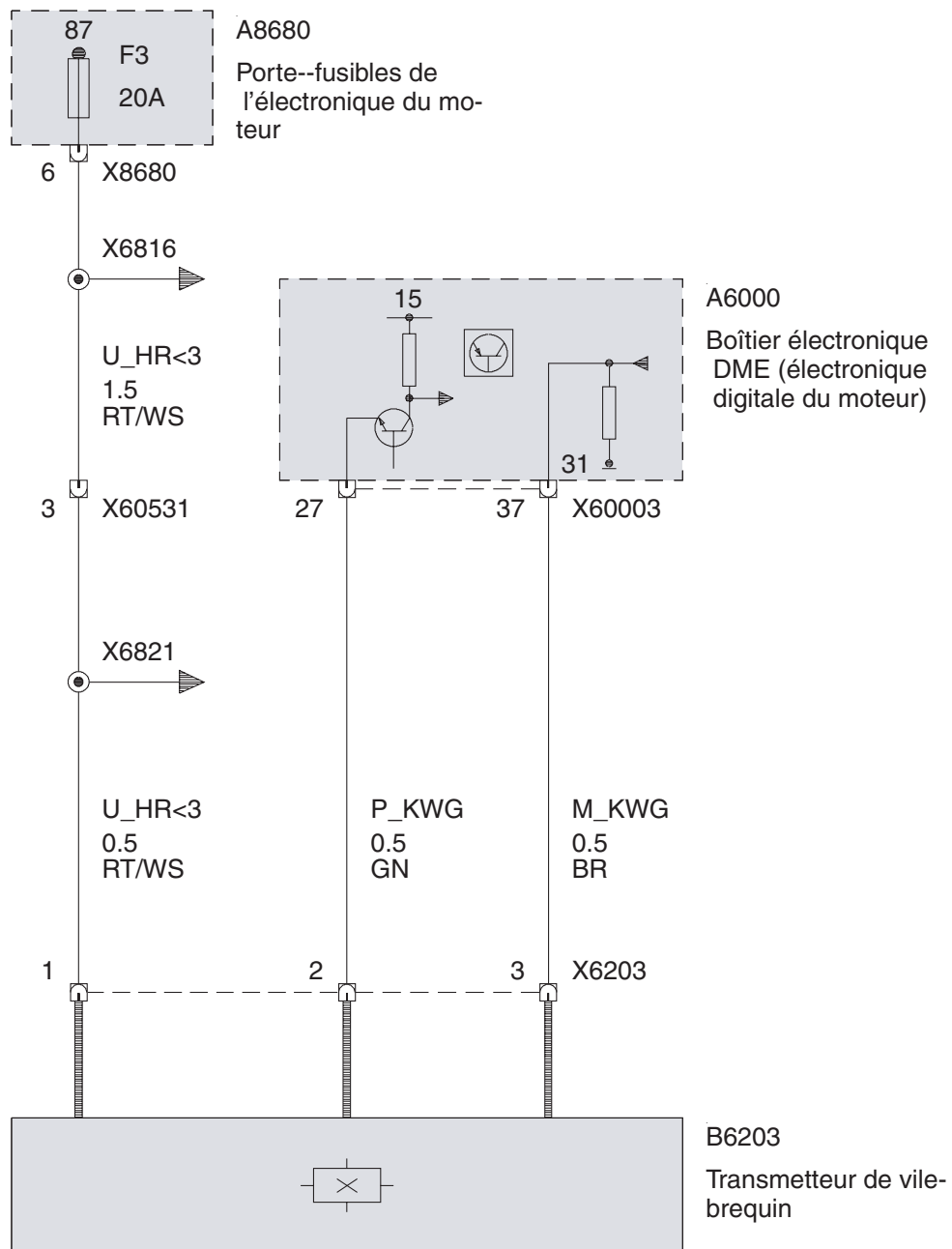

Niveau/température d'huile  
Niveau d'huile (sans Moteur N45)

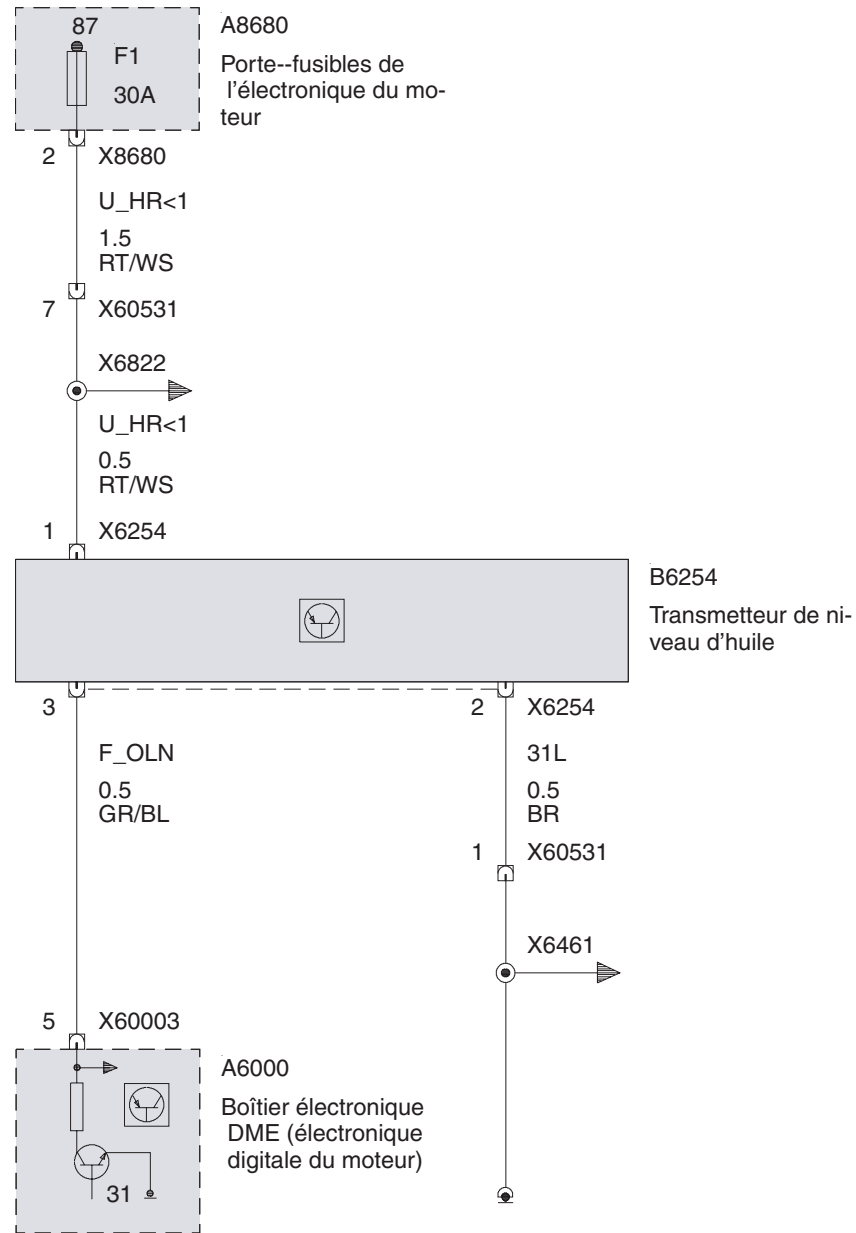

Niveau d'huile (Moteur N45)

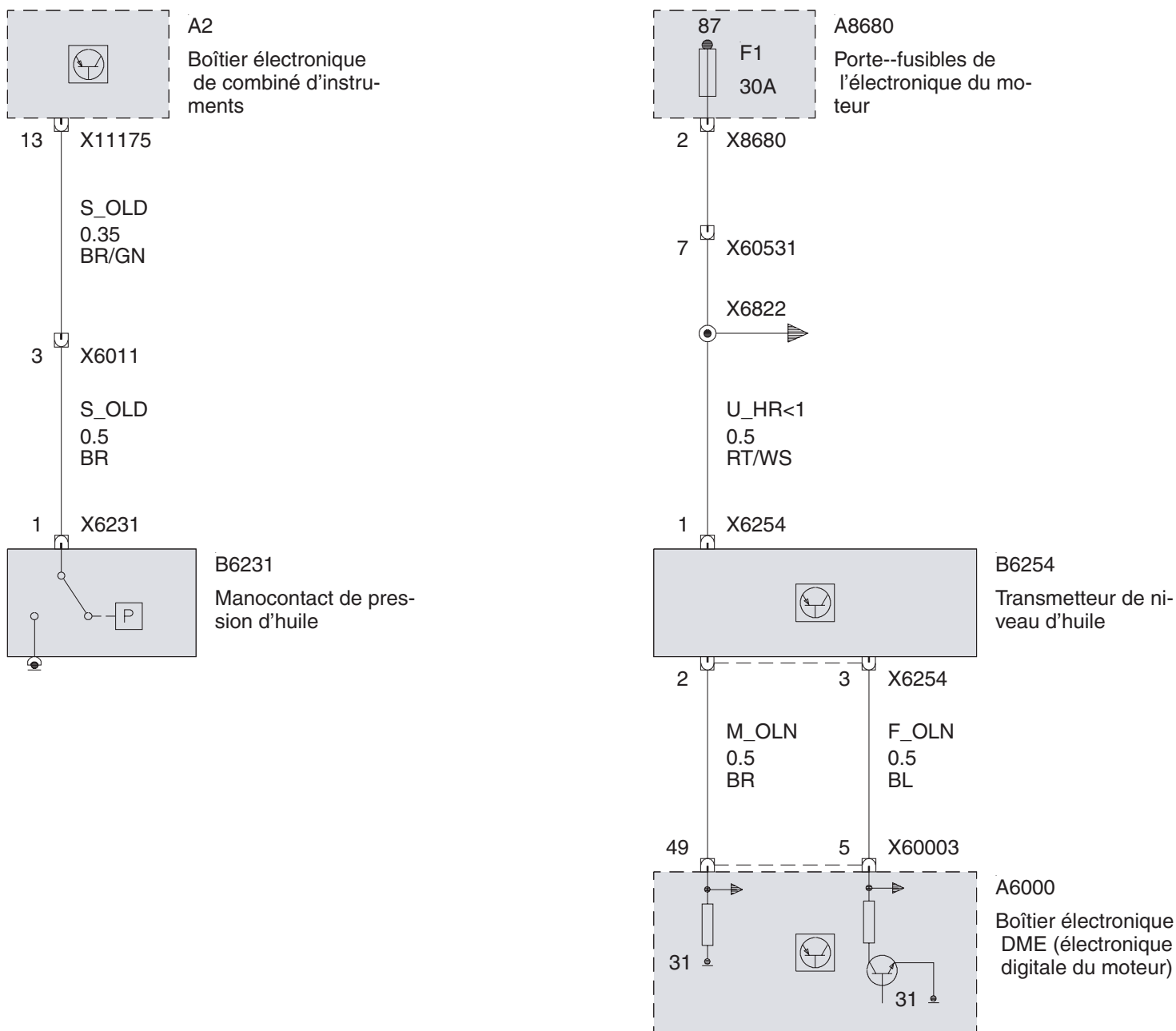

Refroidissement du moteur

Température de liquide de refroidissement/ventilateur électrique (jusque 2003\_03)

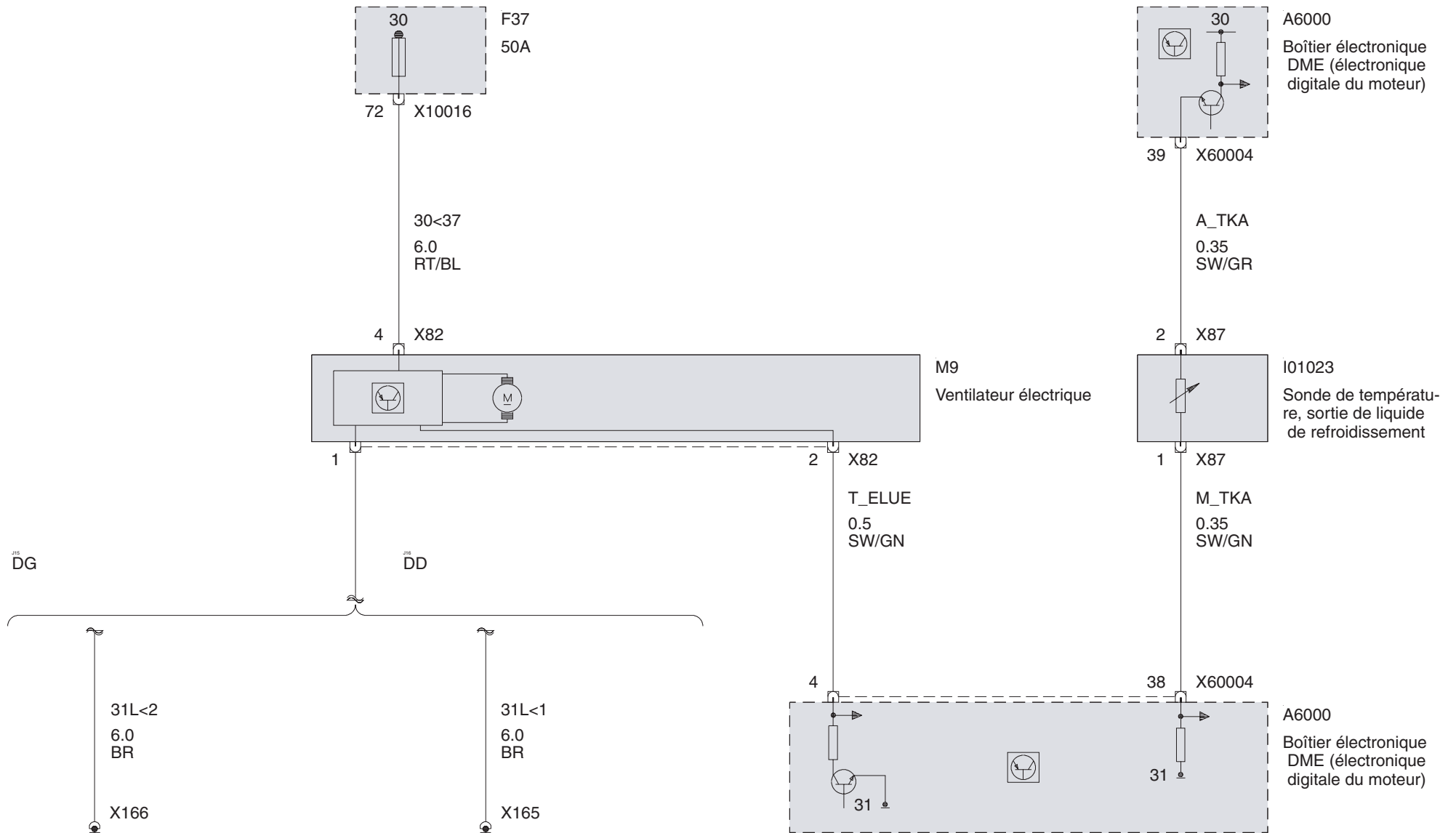

Température de liquide de refroidissement/ventilateur électrique (( Berline ou Compact ou Touring ) à partir de 2003\_03)

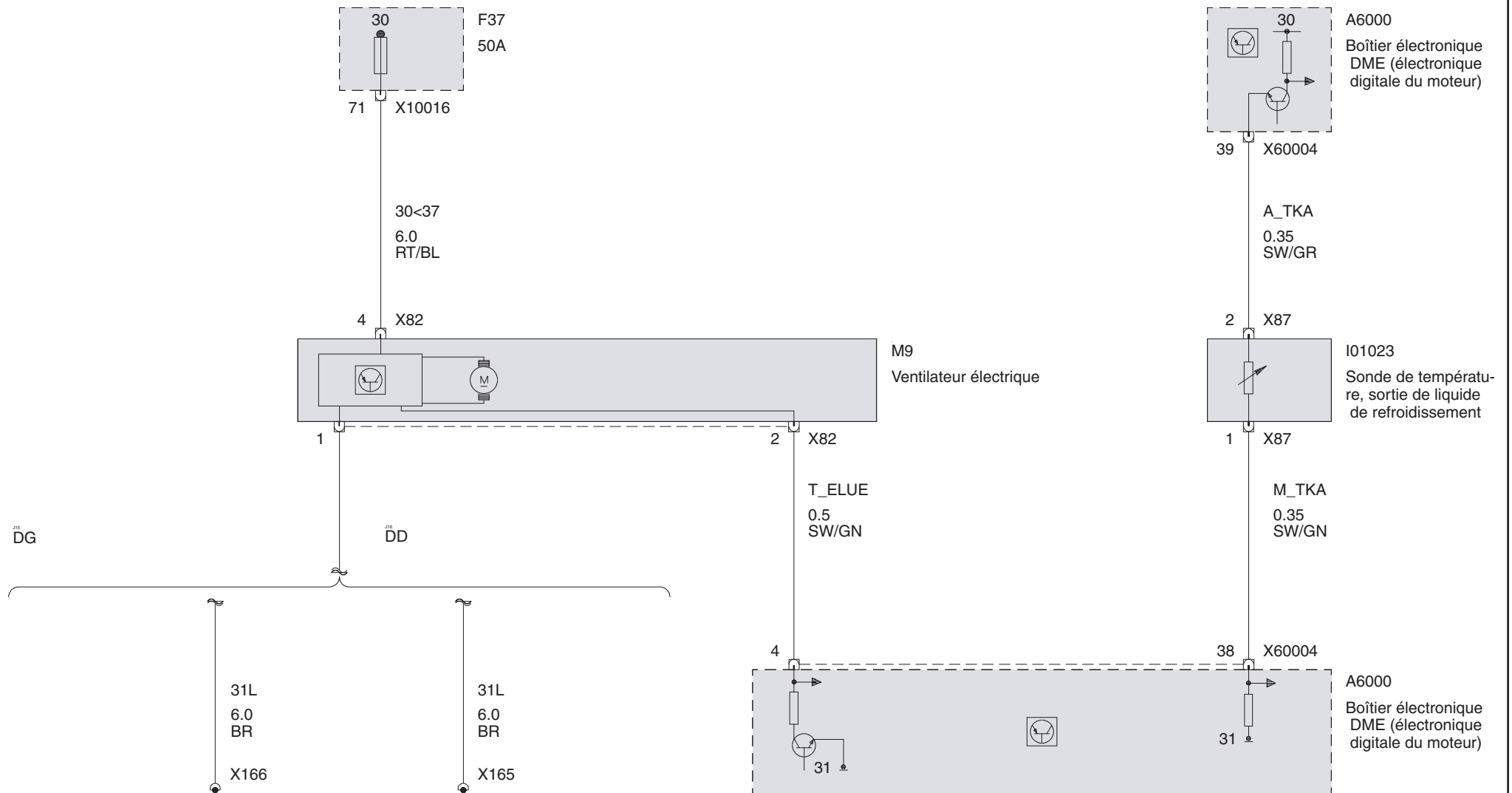

Température de liquide de refroidissement/ventilateur électrique (( Coupé ou Cabriolet ) à partir de 2003\_03)

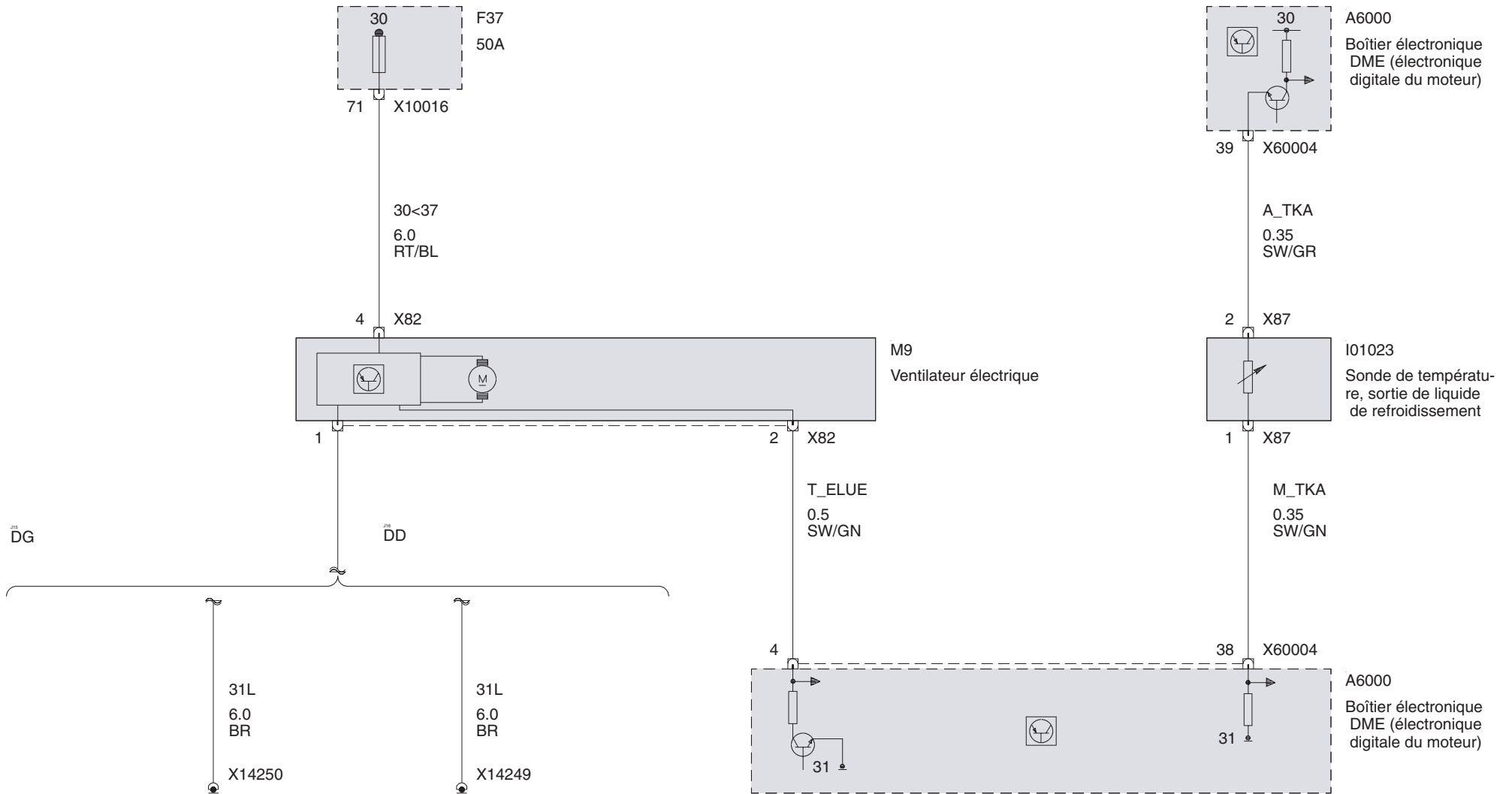

Thermostat cartographique (à partir de 2001\_09)

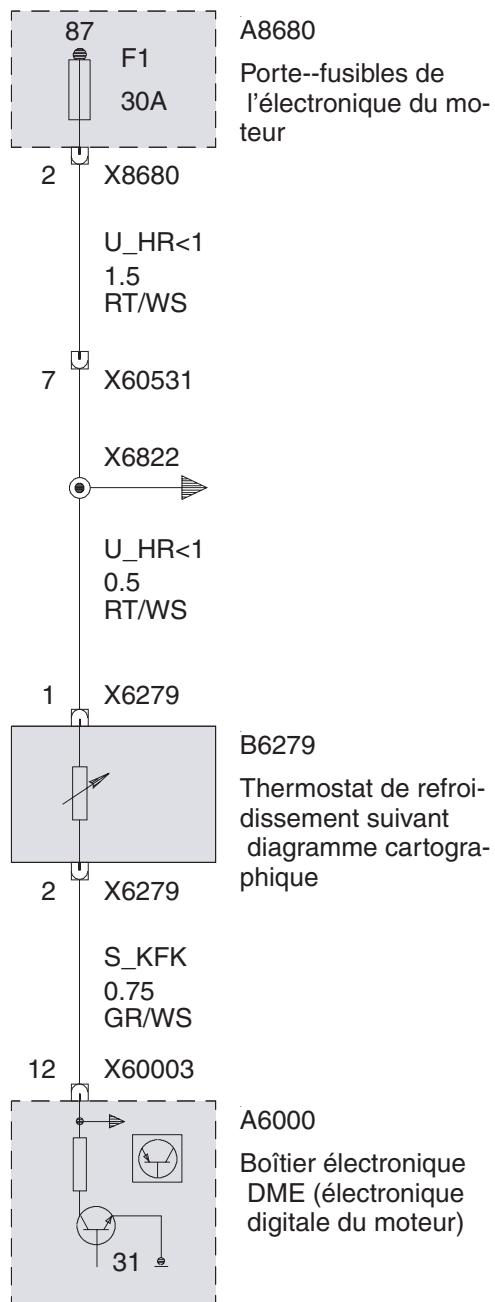



## Sonde de température de liquide de refroidissement du moteur

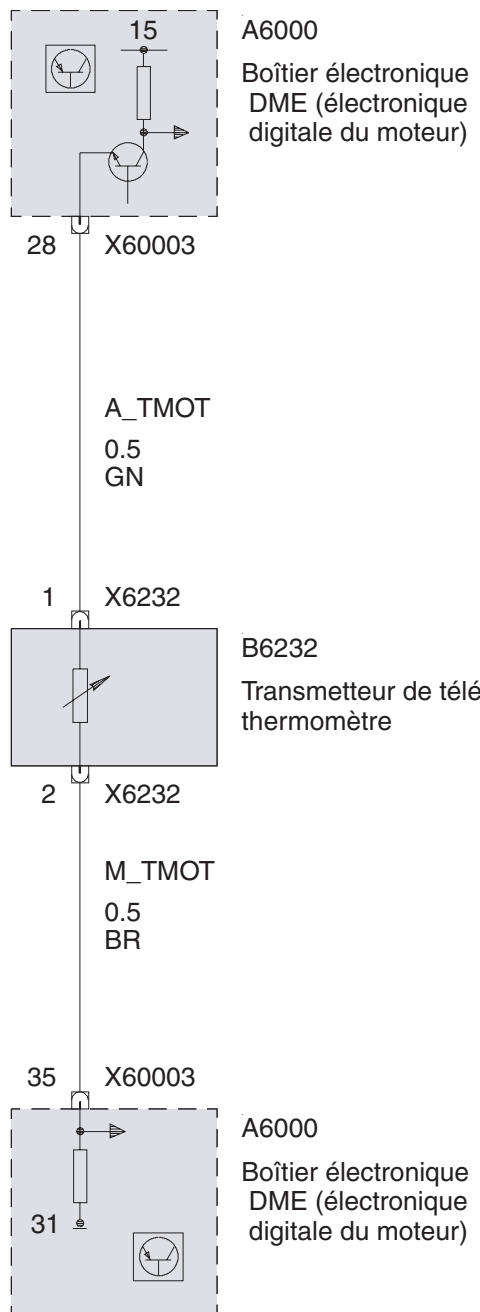

Distribution

Distribution variable (Valvetronic) (Moteur N42)

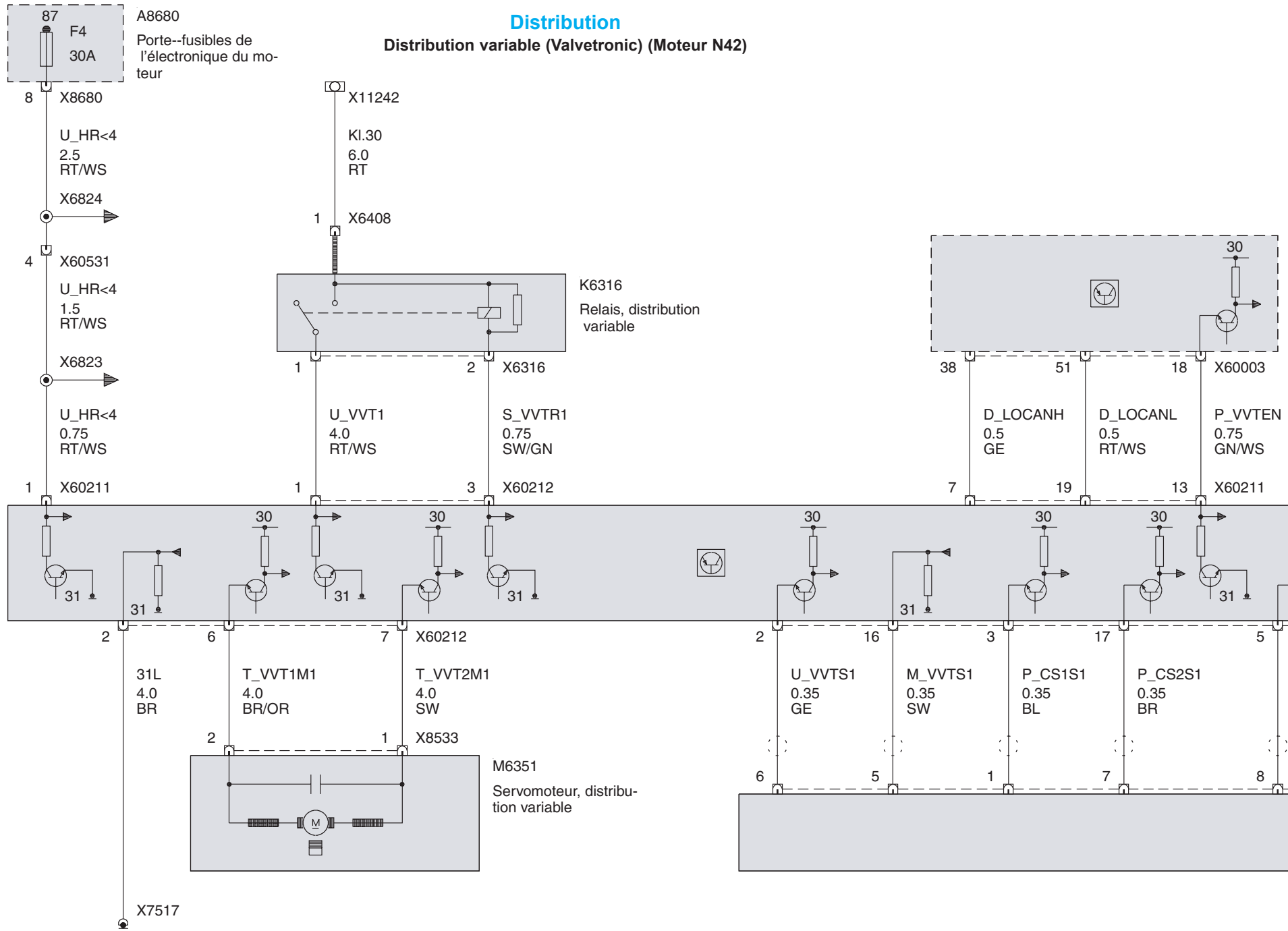

A6000  
Boîtier électronique  
DME (électronique  
digitale du moteur)

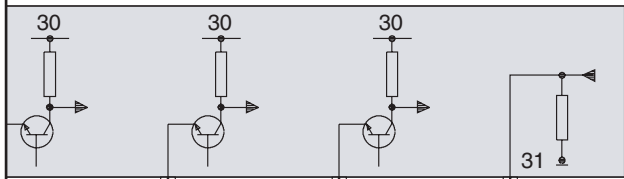

A60210  
Boîtier électronique  
de distribution varia-  
ble

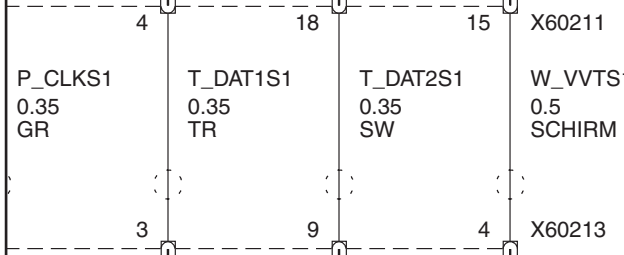

B60213  
Transmetteur de posi-  
tion, distribution varia-  
ble

Capteur d'arbre à cames

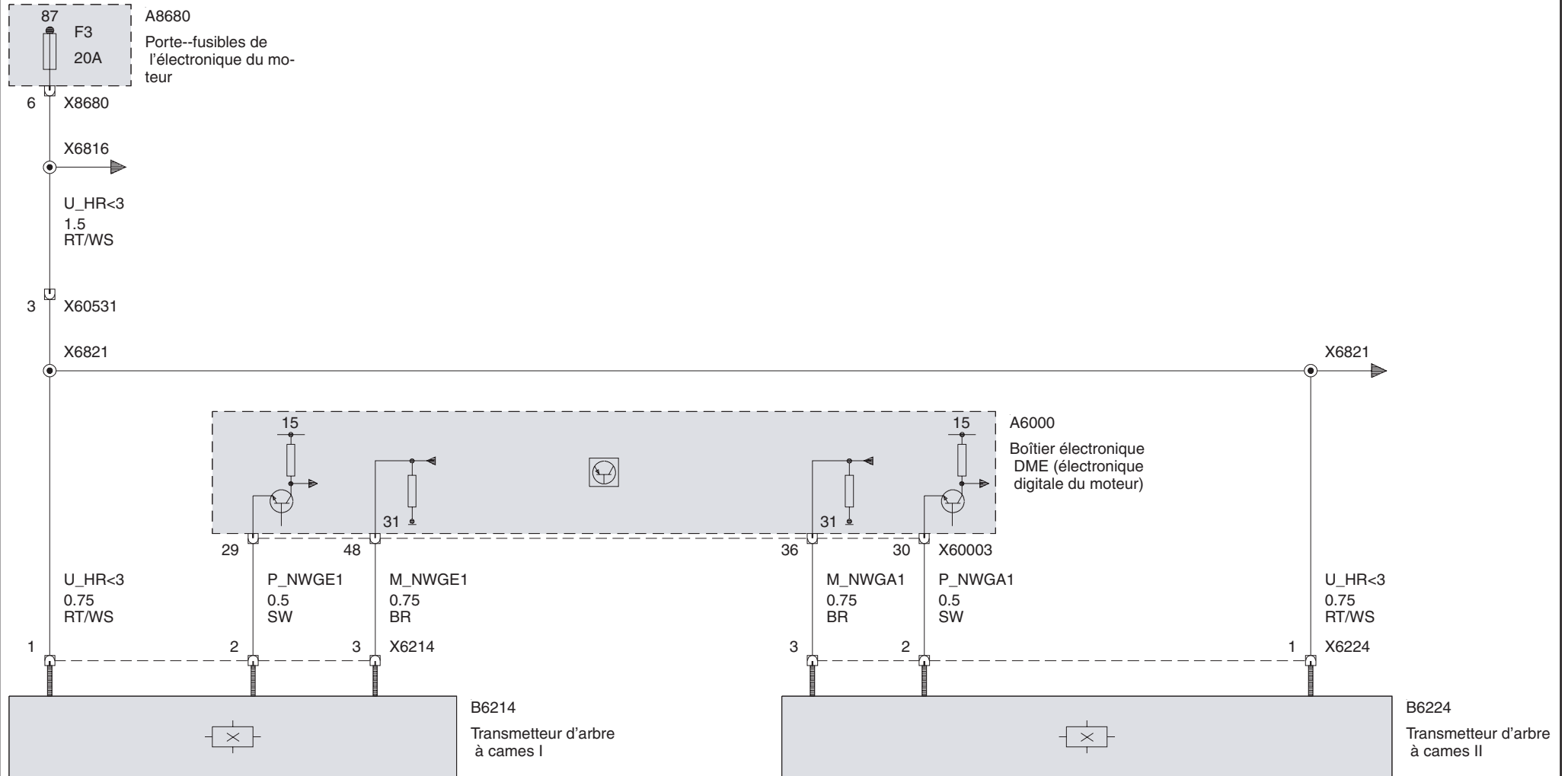

Electrovannes VANOS (sauf Moteur N45)

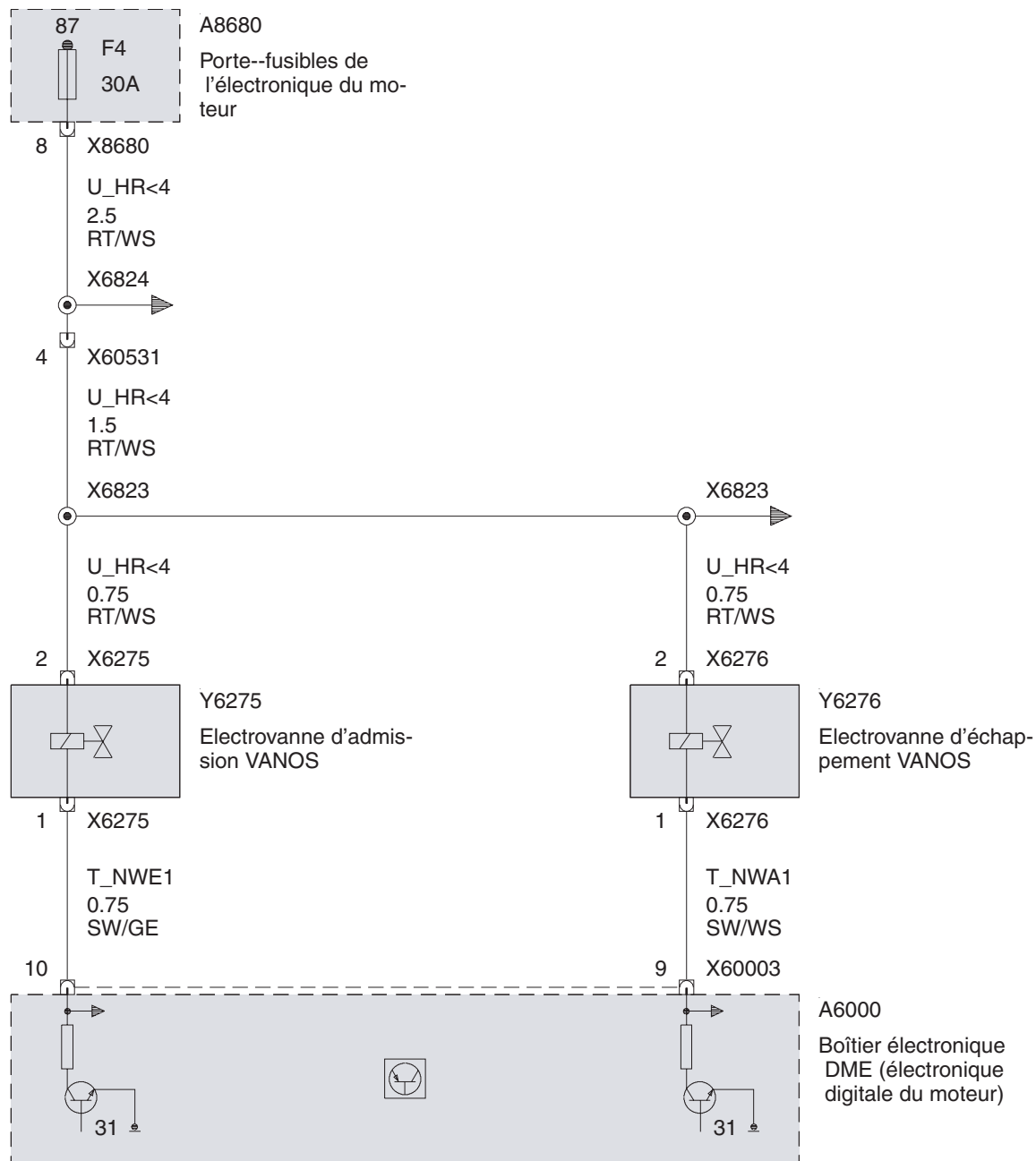

Electrovannes VANOS (Moteur N45)

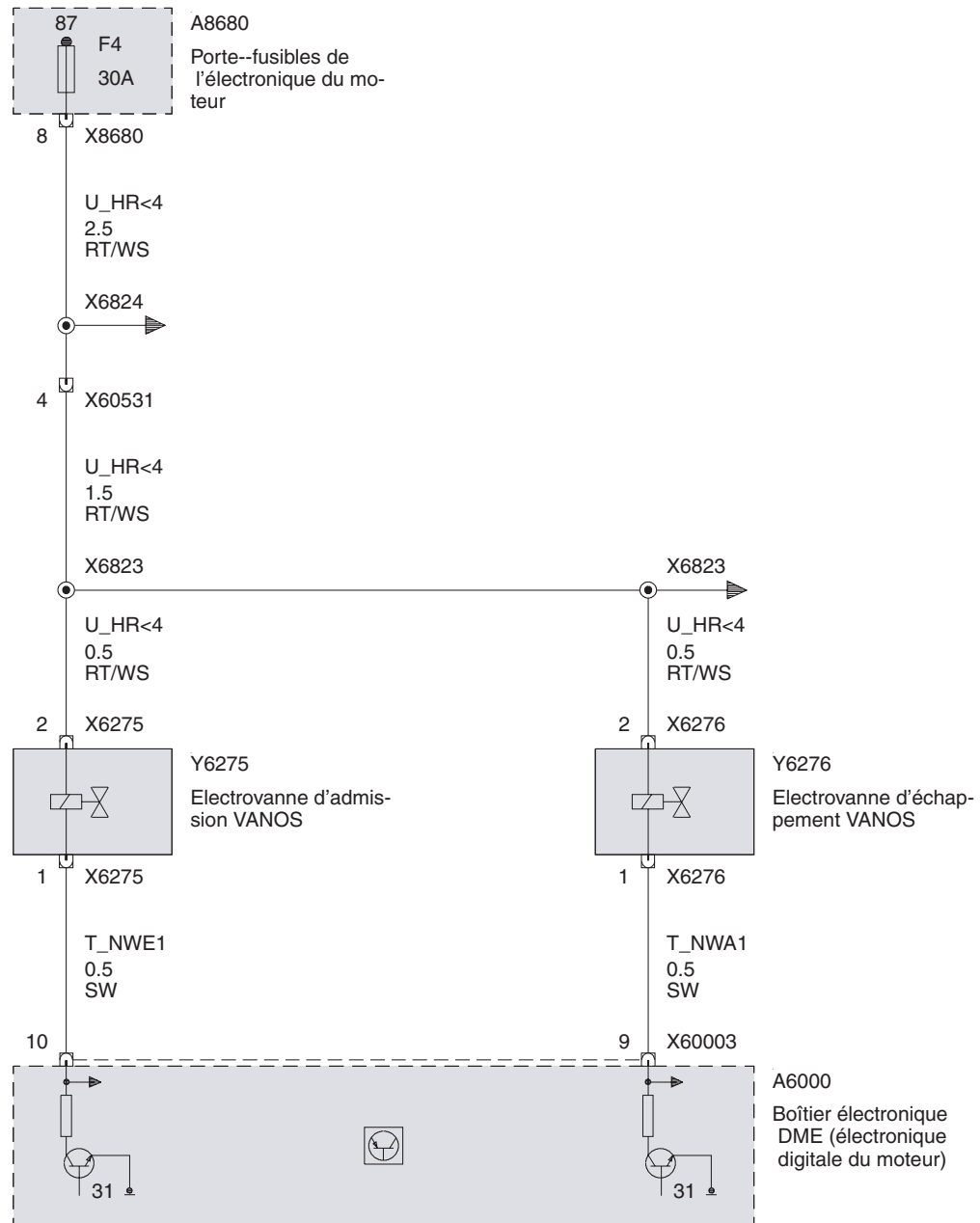

Signal de vitesse

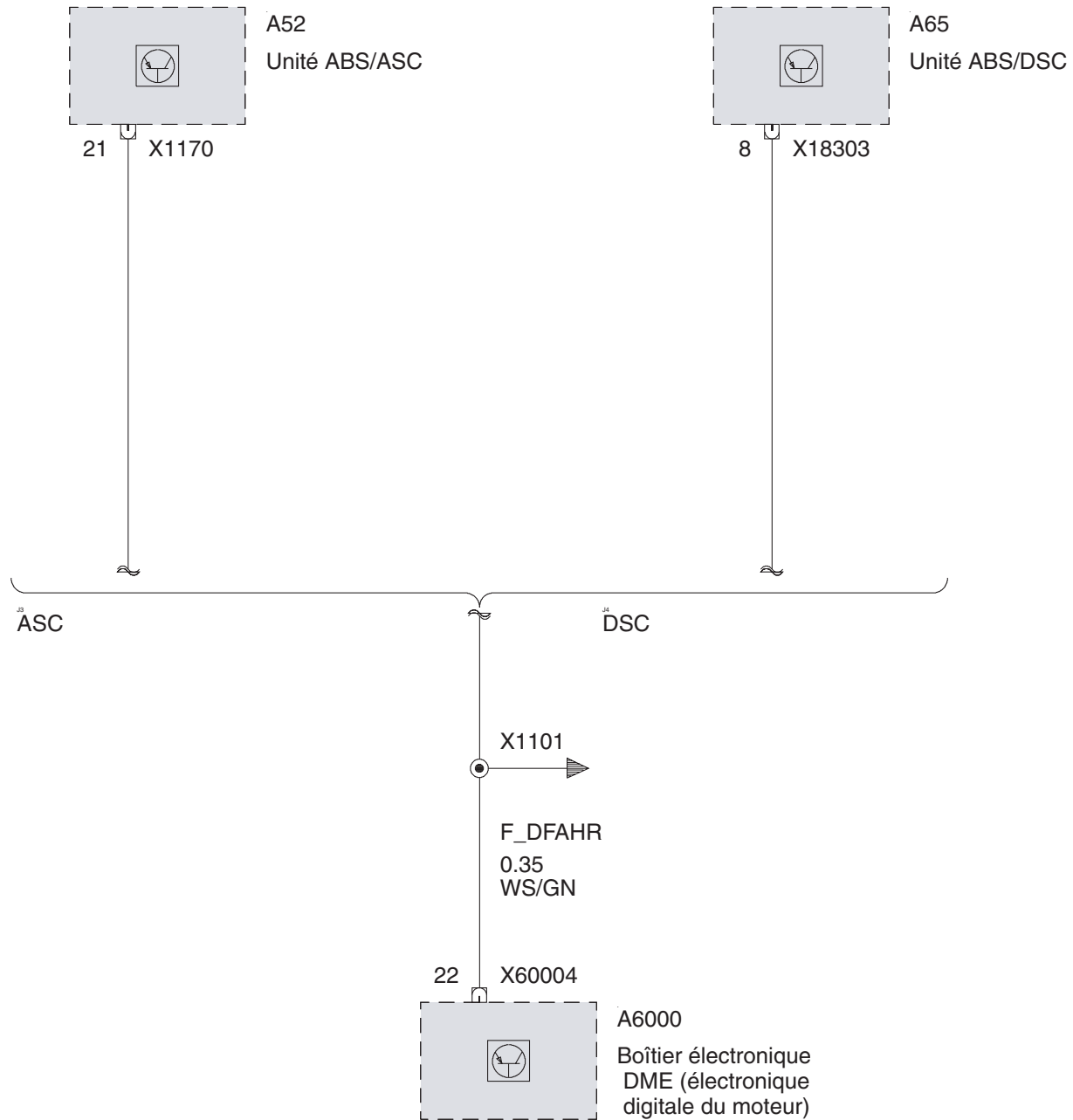

## Blocage antidémarrage électronique (EWS)

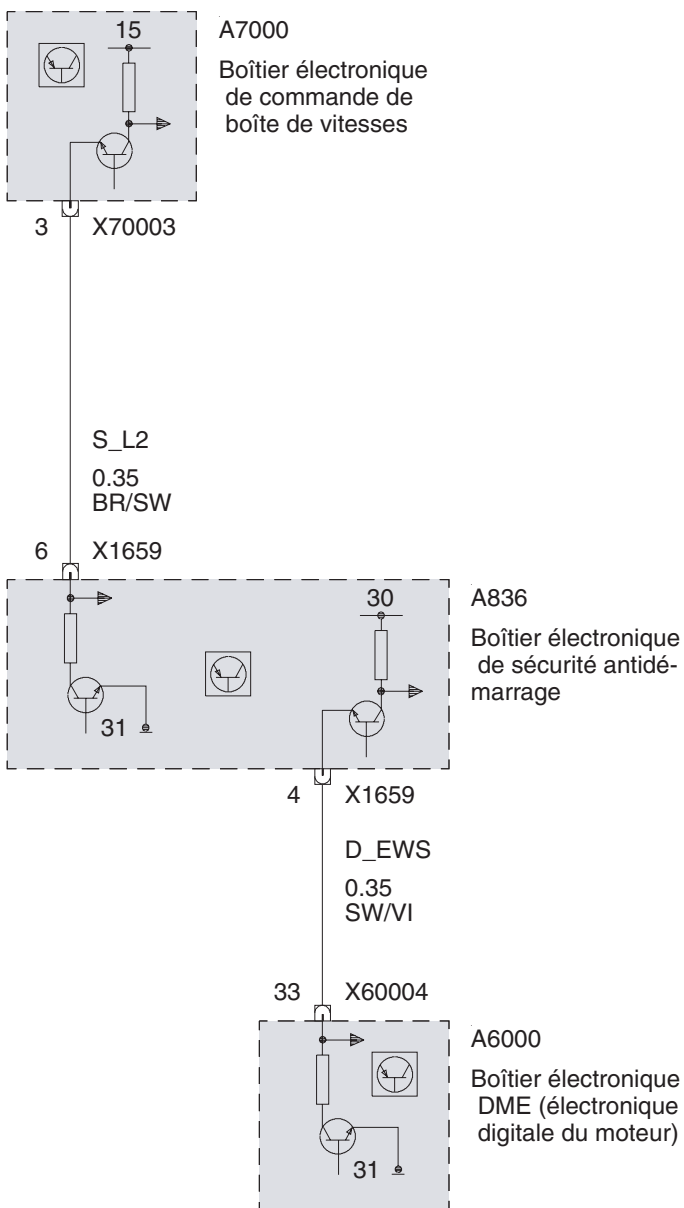



Pompe d'insufflation d'air secondaire

Système d'insufflation de l'air secondaire (jusque 2003\_03)

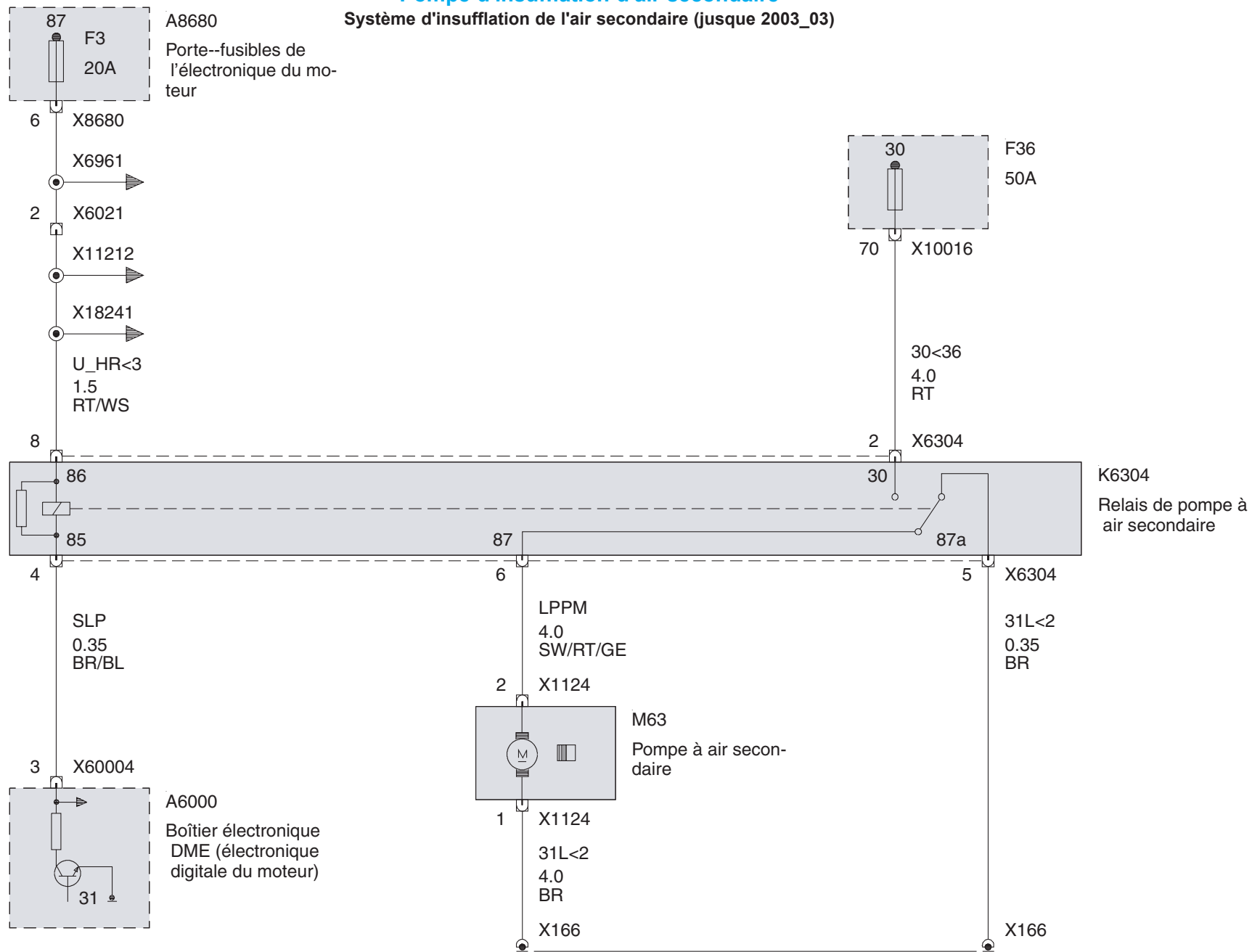

Système d'insufflation de l'air secondaire (à partir de 2003\_03)

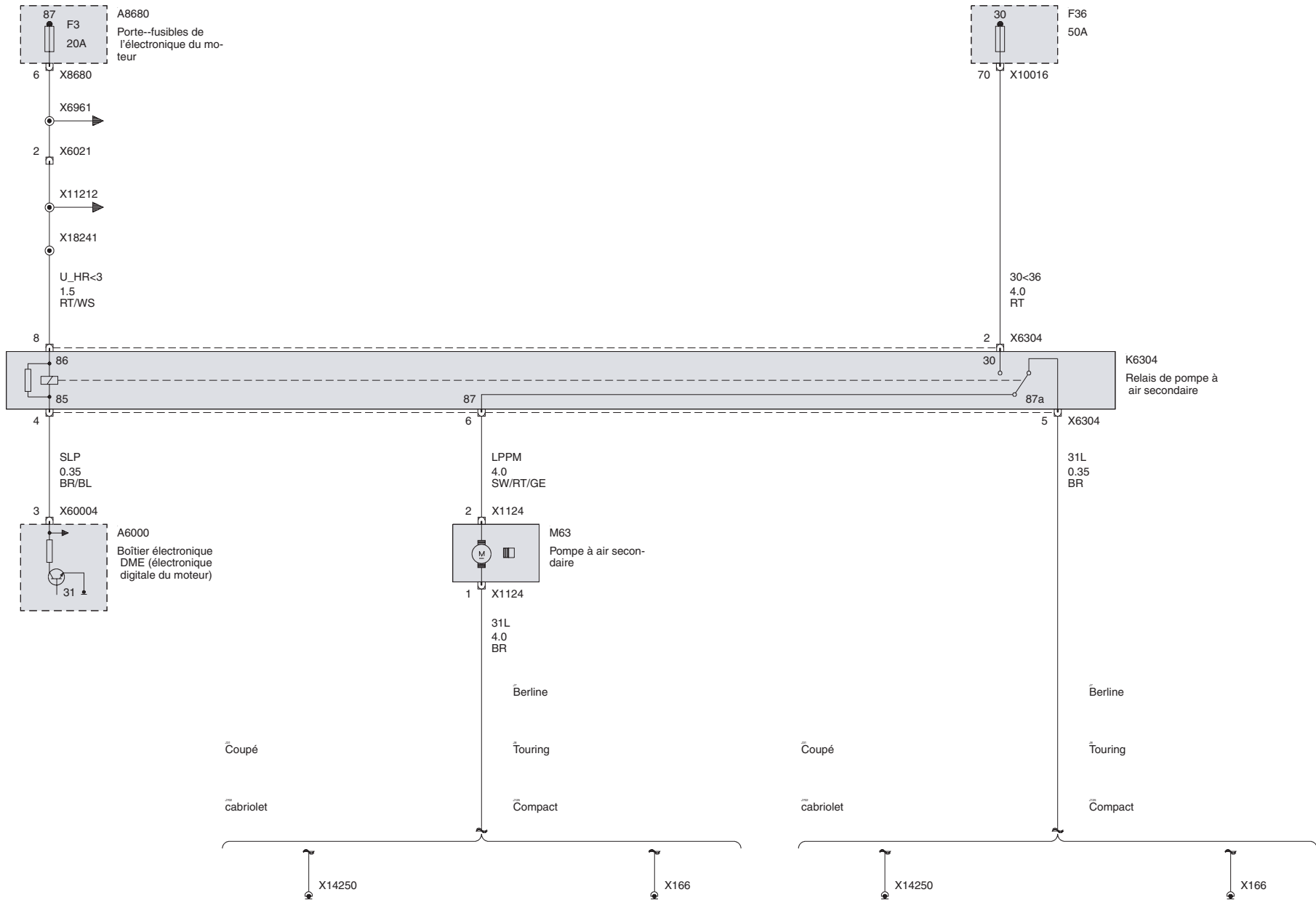

## Vanne de dégazage réservoir

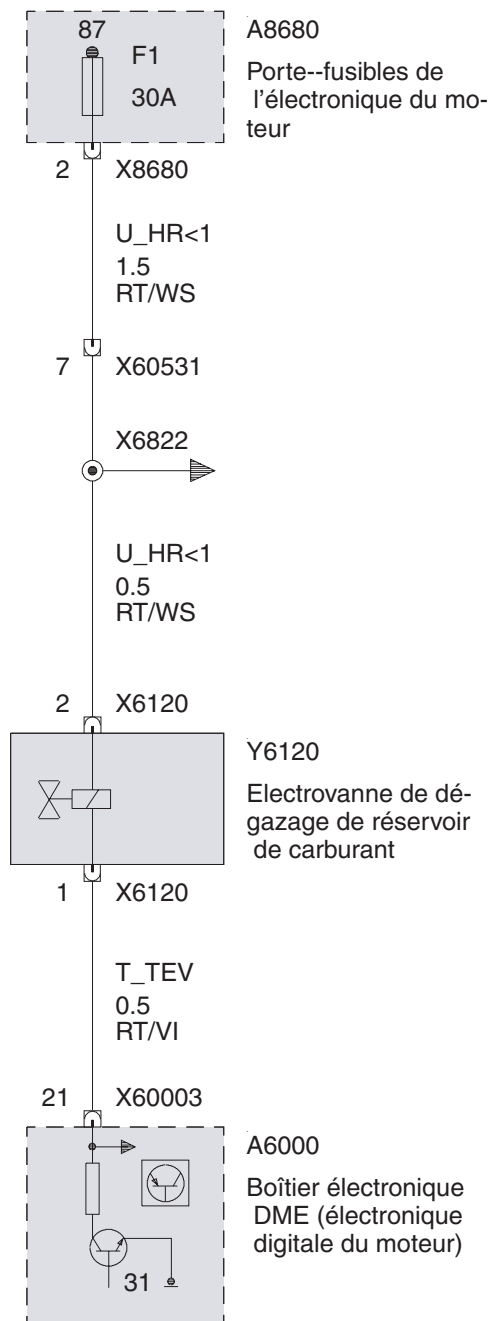

Alimentation en tension  
Relais principal DME

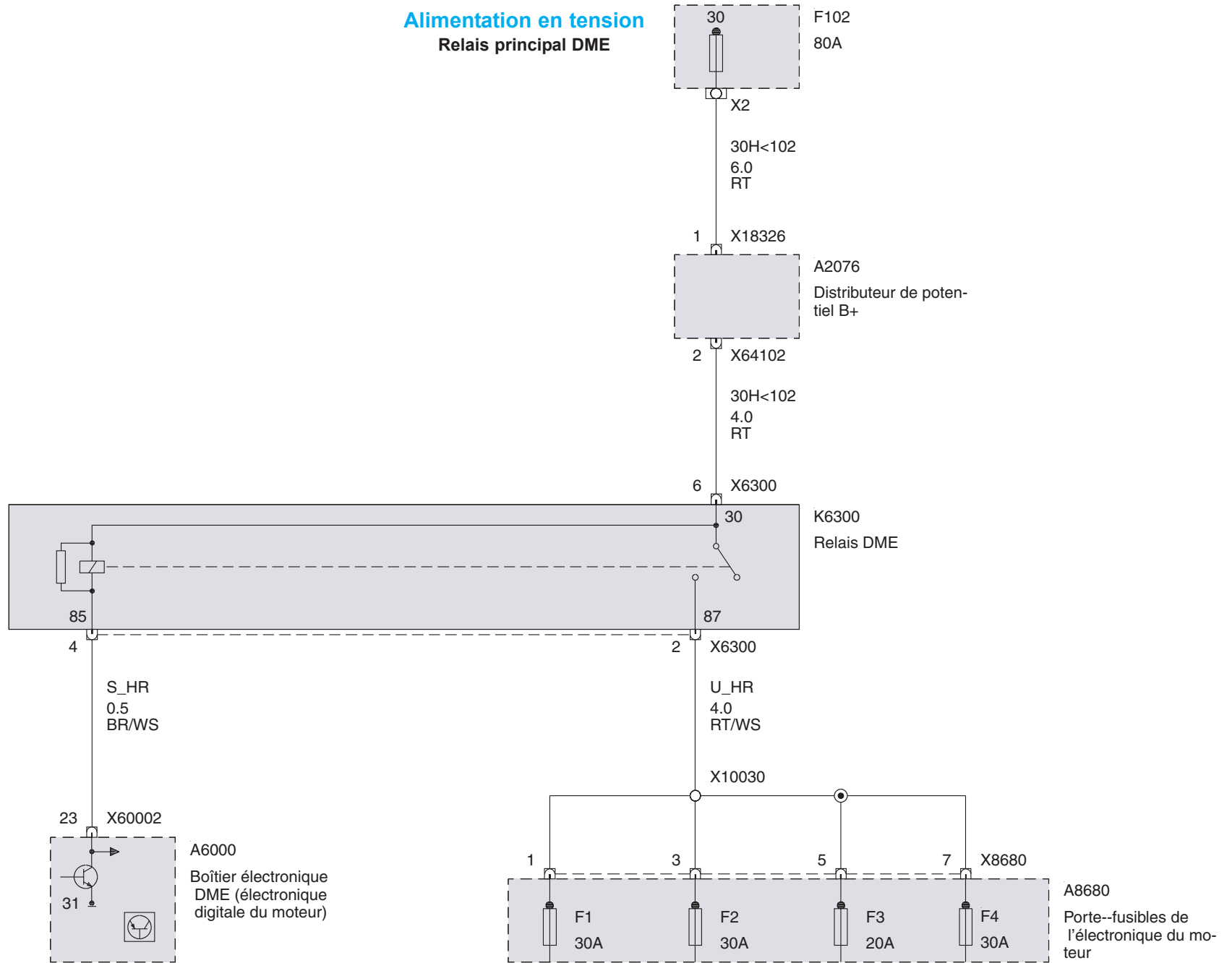

Alimentation Boîtier électronique DME (sauf Moteur N45)

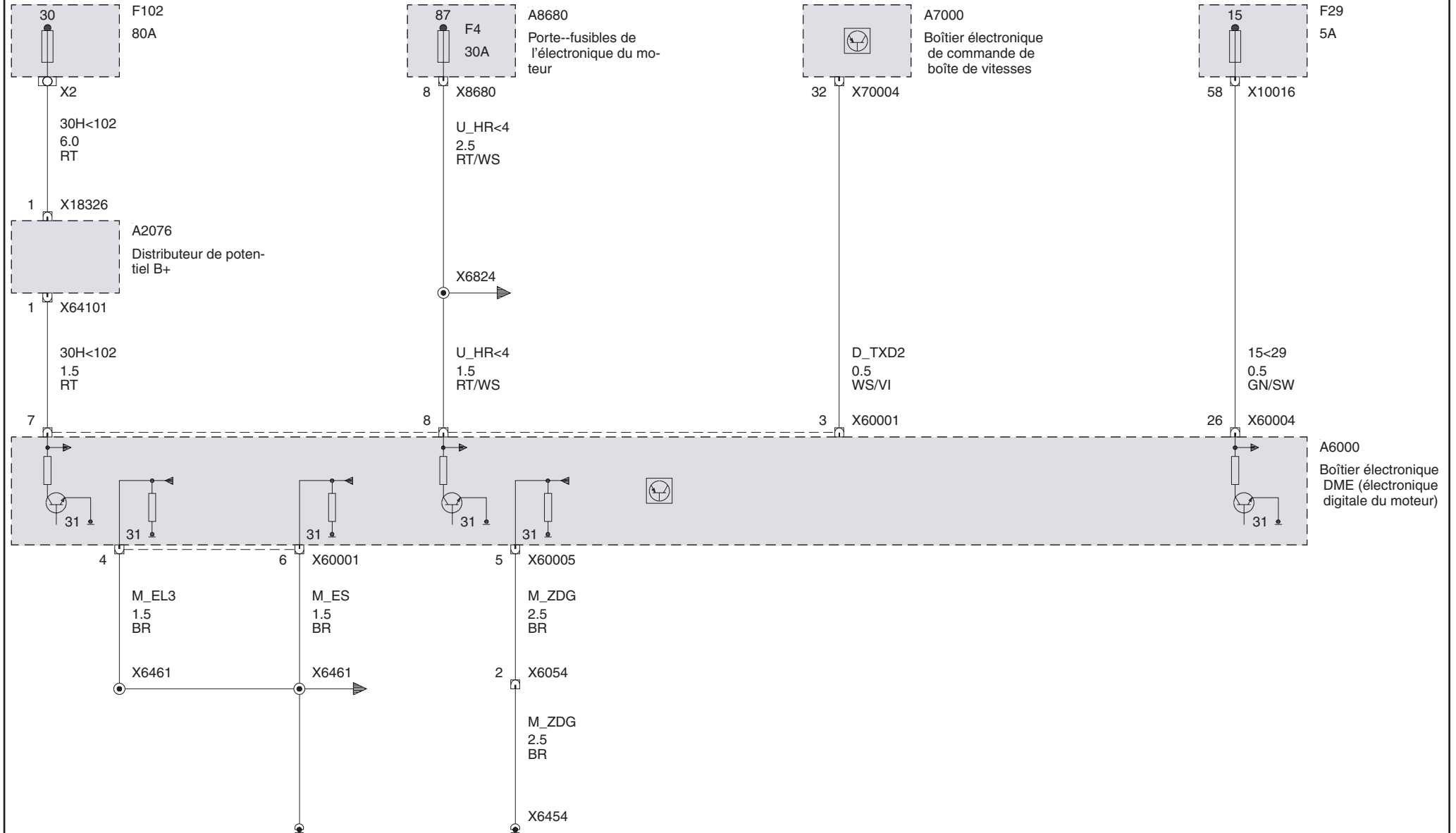

Alimentation Boîtier électronique DME (Moteur N45)

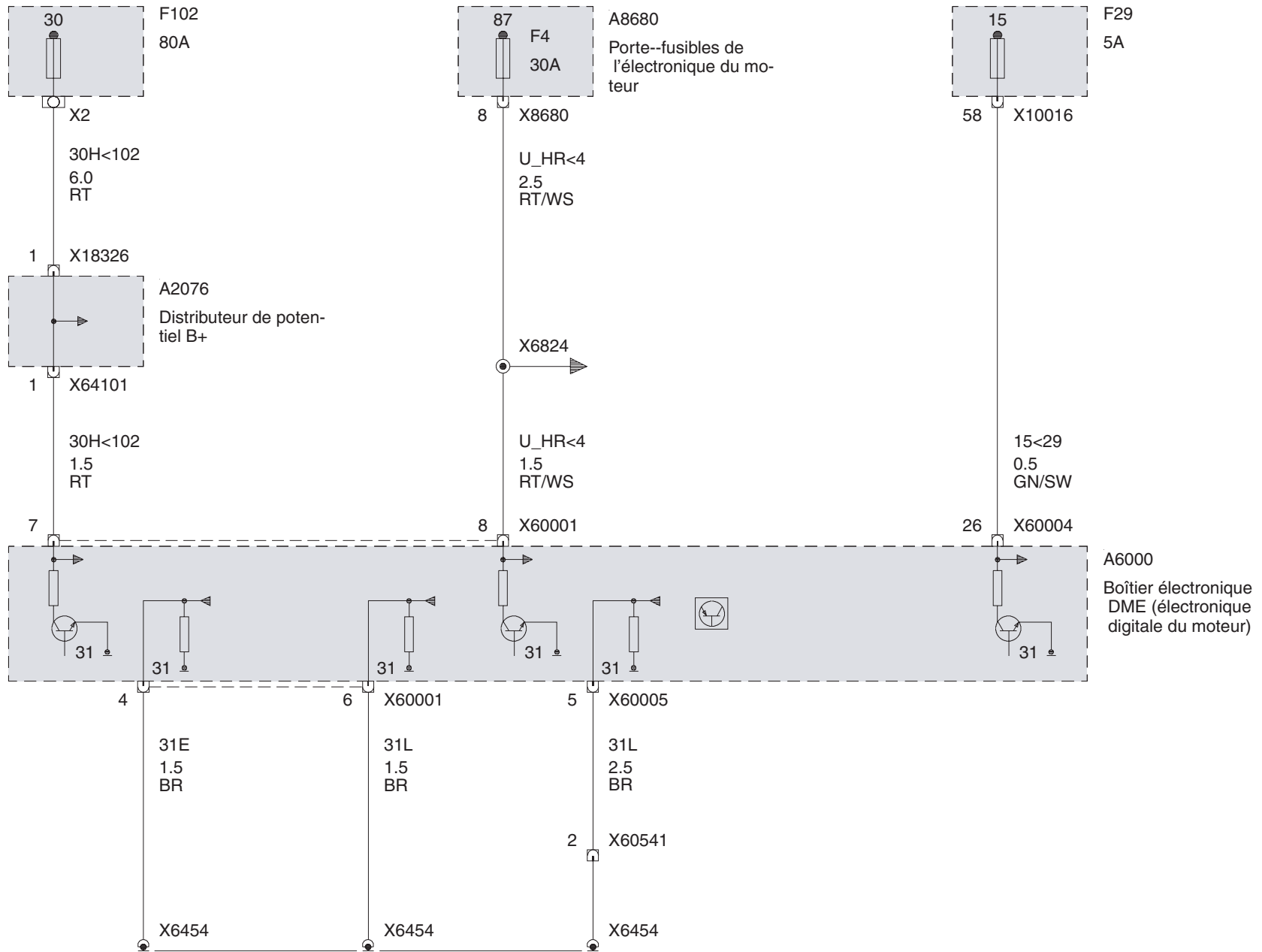

# Gestion moteur diesel DDE5.0 (DDE Electronique Diesel DDE50 ou DDE Electronique numerique diesel UE4)

## Commande du moteur, régulation du carburant/alimentation (Moteur M47/TU jusque 2003\_03)

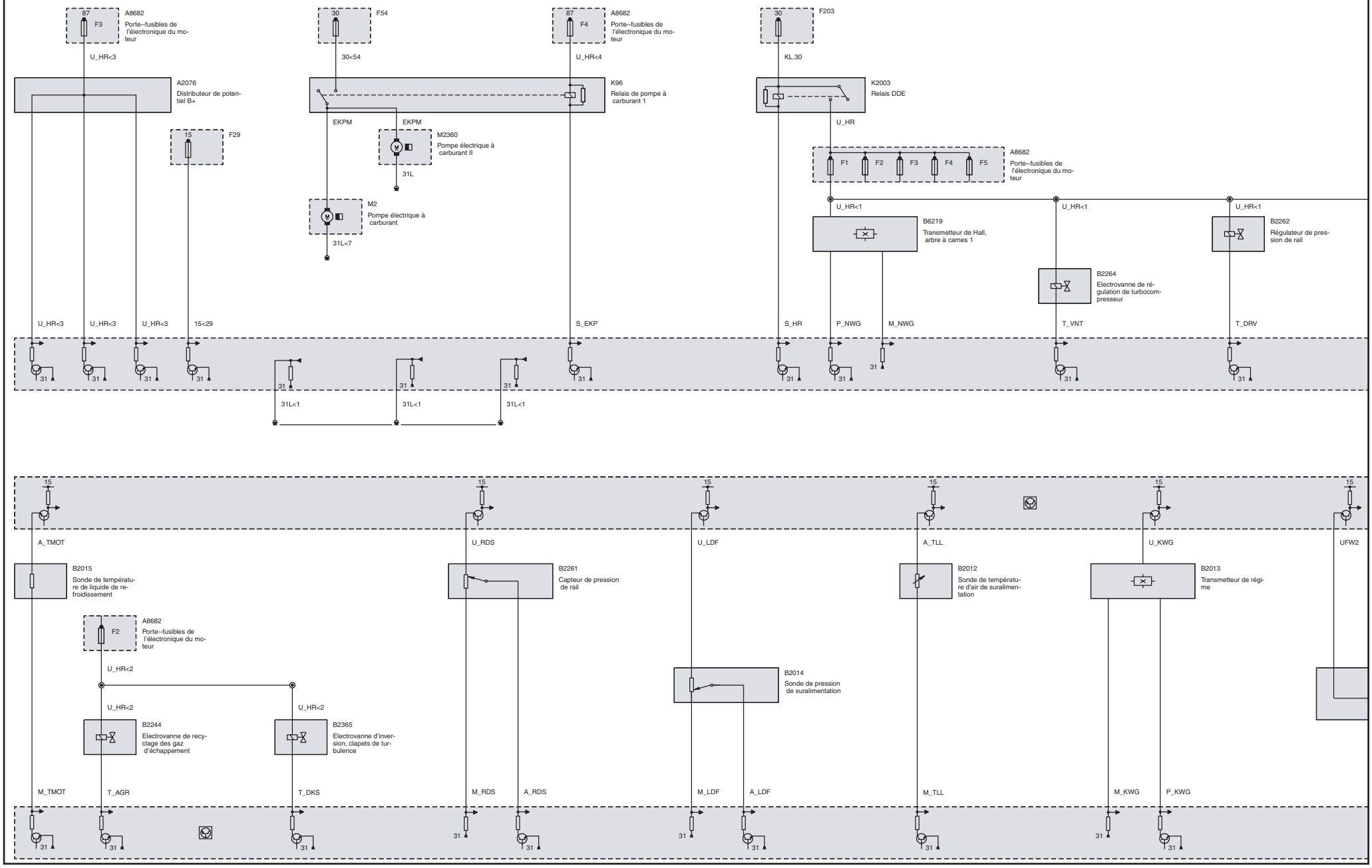

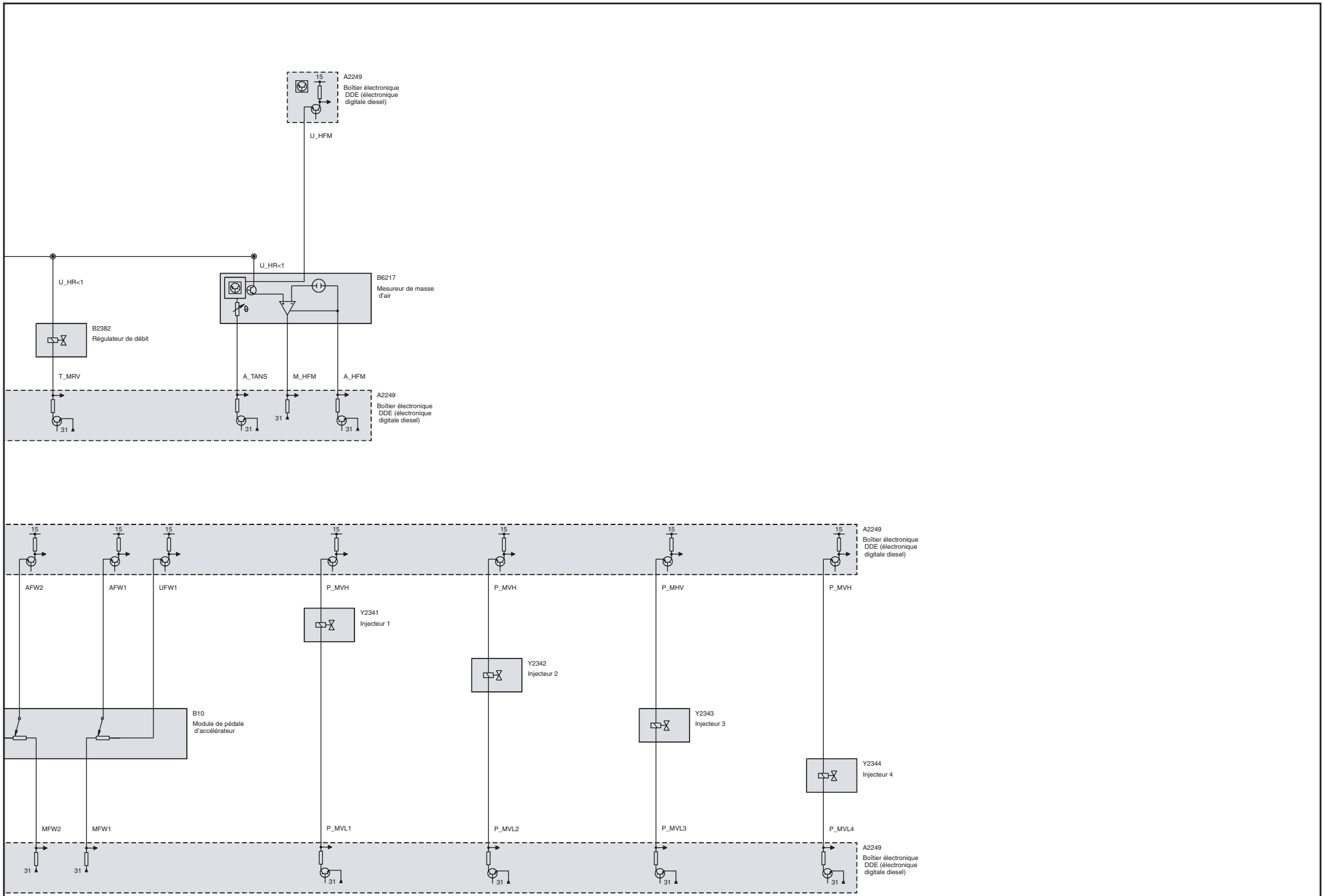



Commande du moteur, régulation du carburant/alimentation (Moteur M47/TU à partir de 2003\_03)

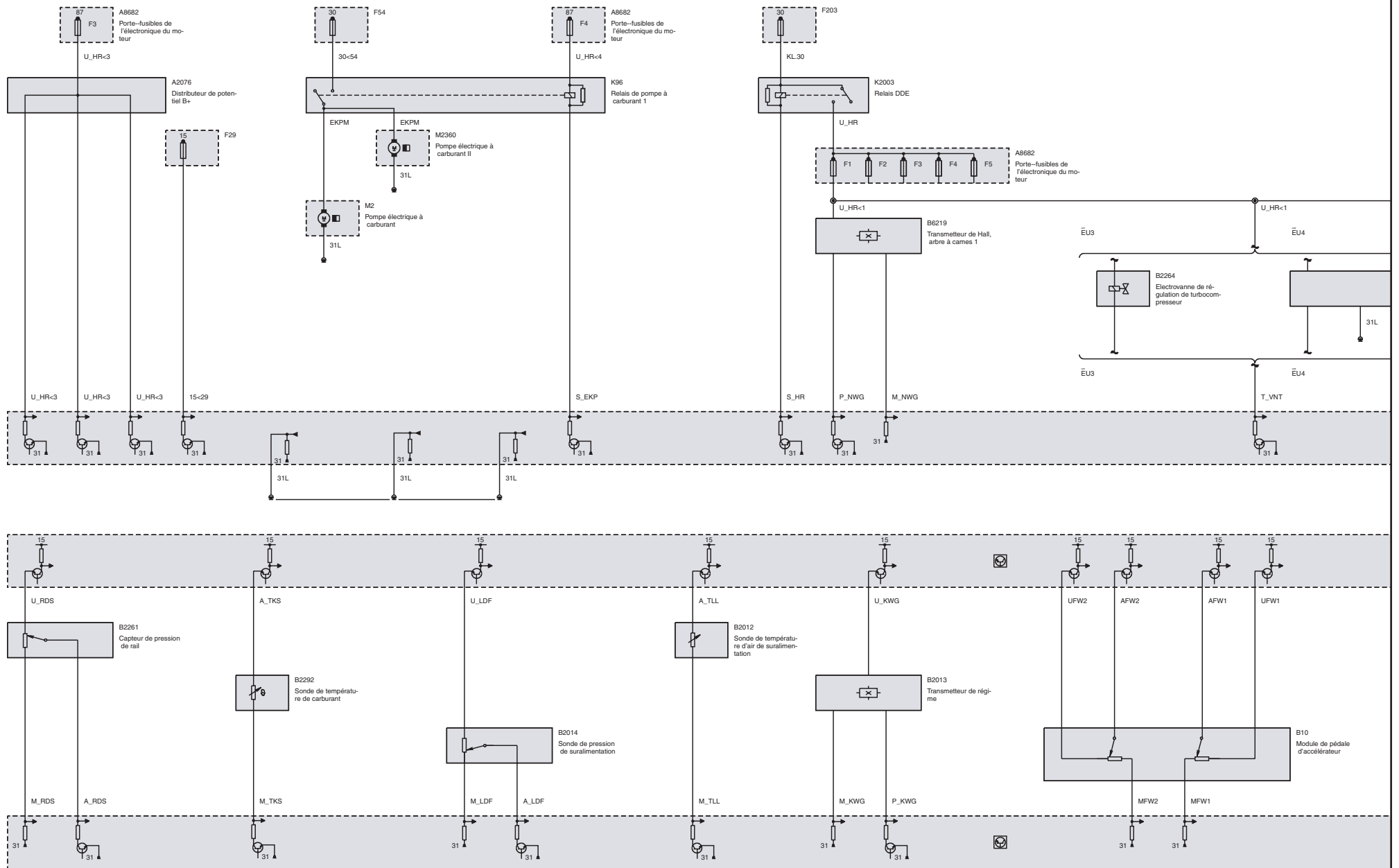

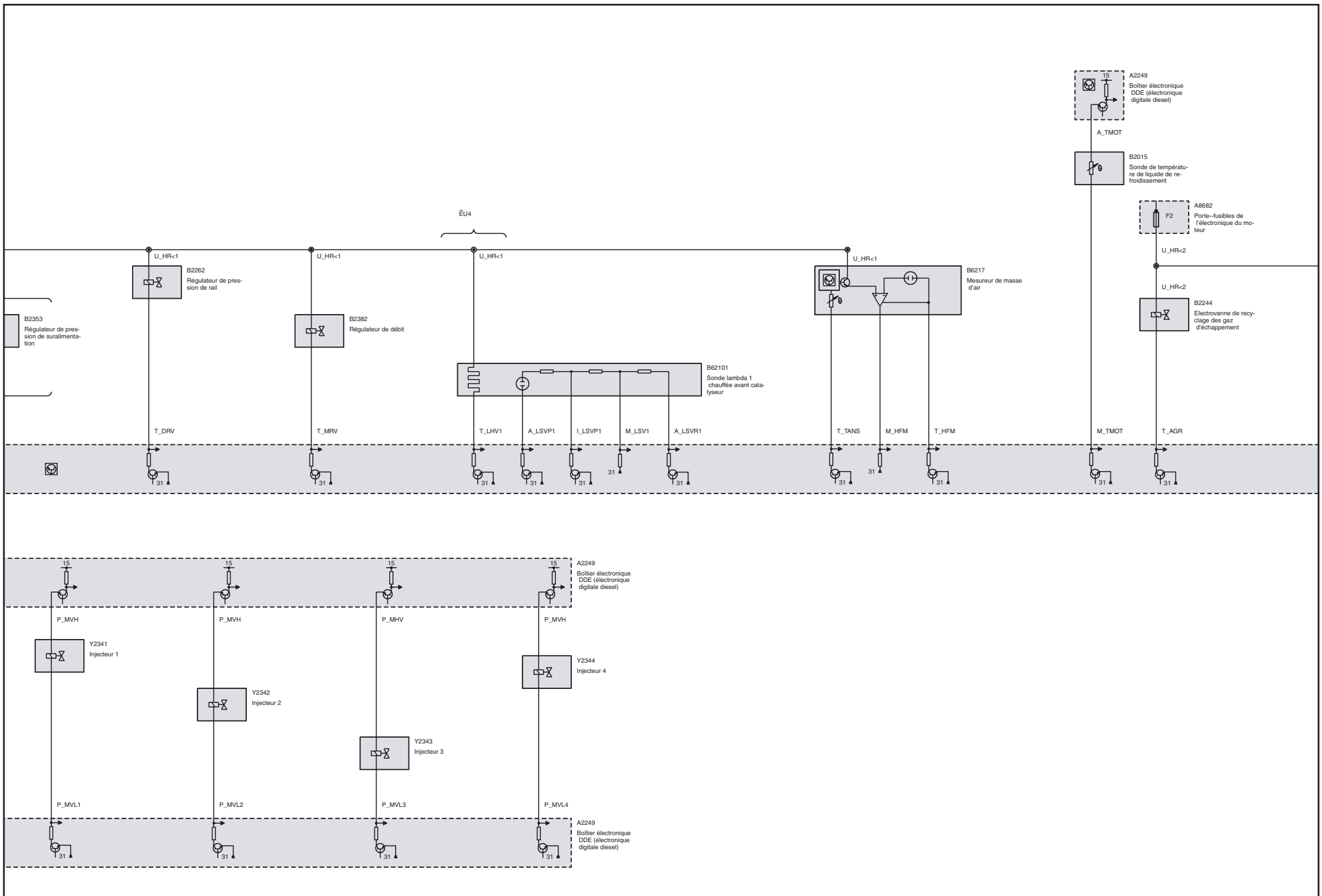

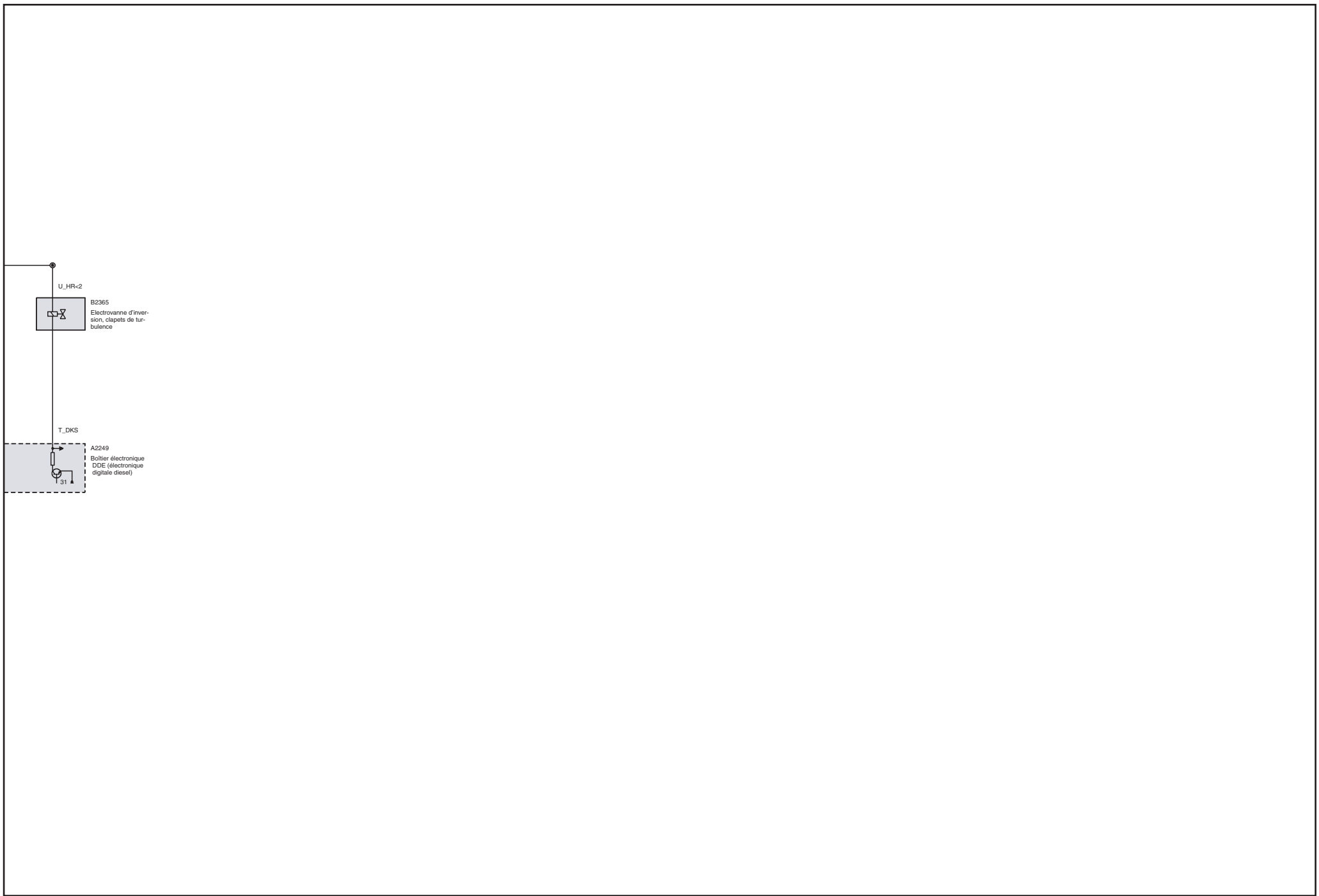

Commande du moteur, fonctions/signaux (Moteur M47/TU)

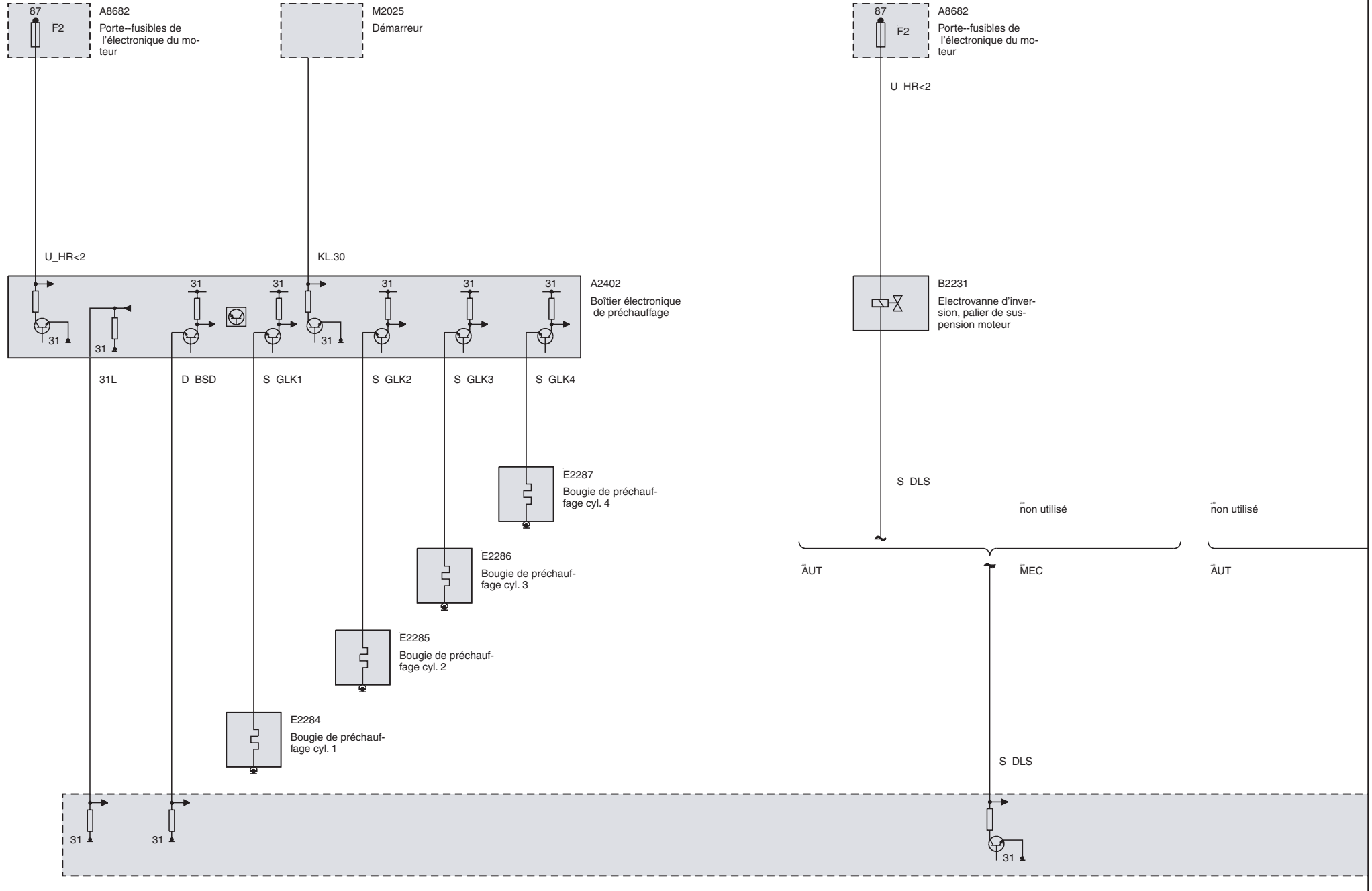

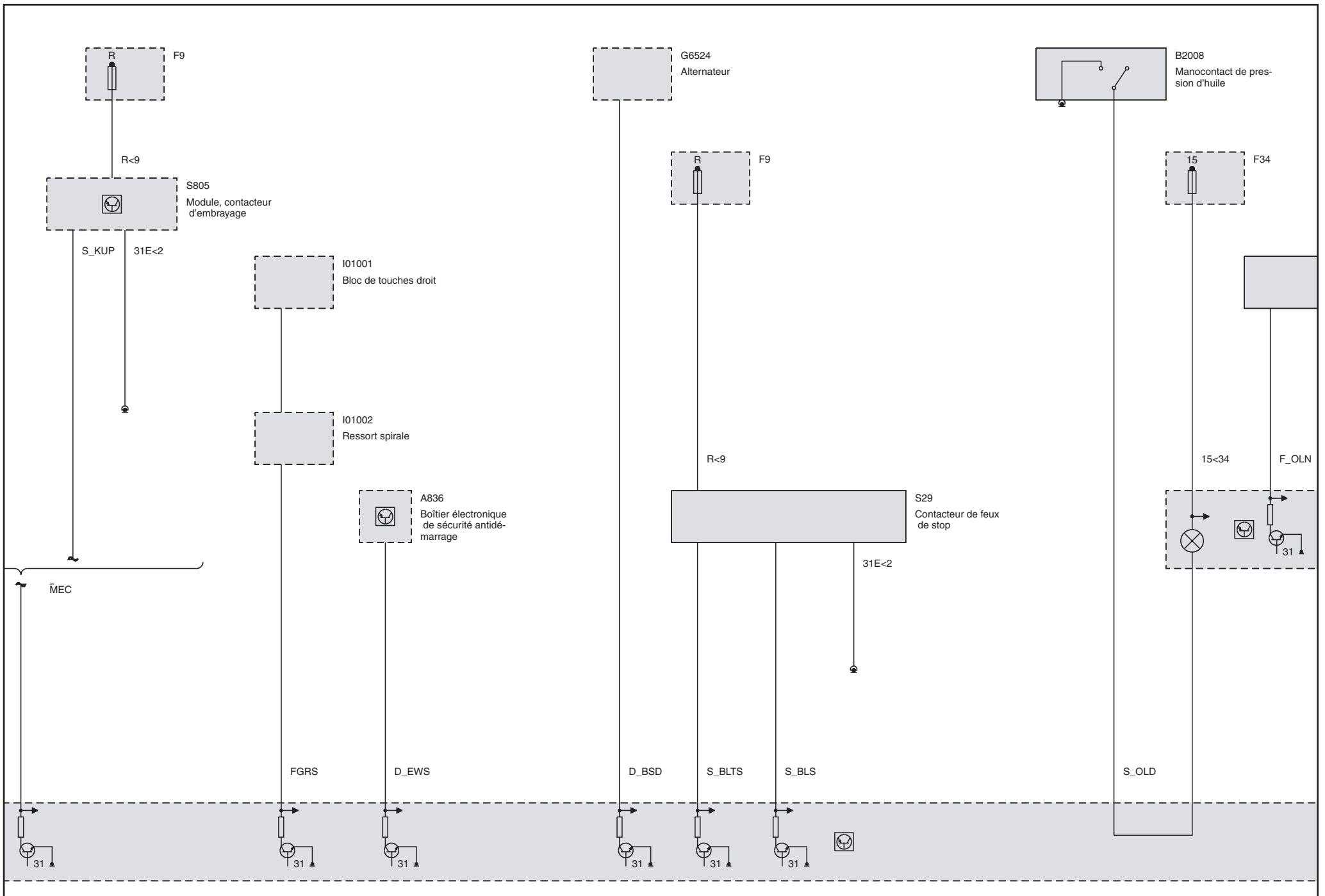

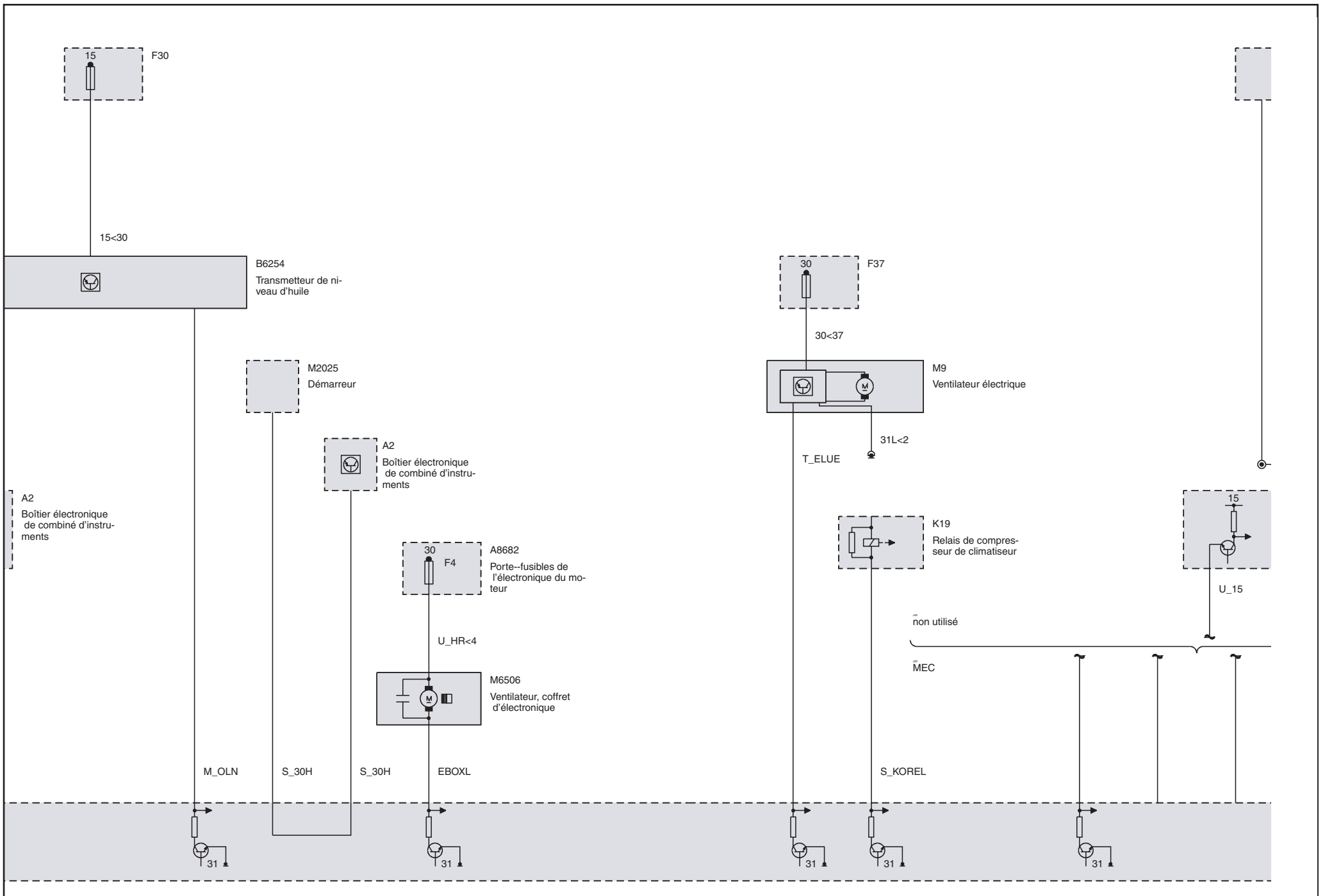

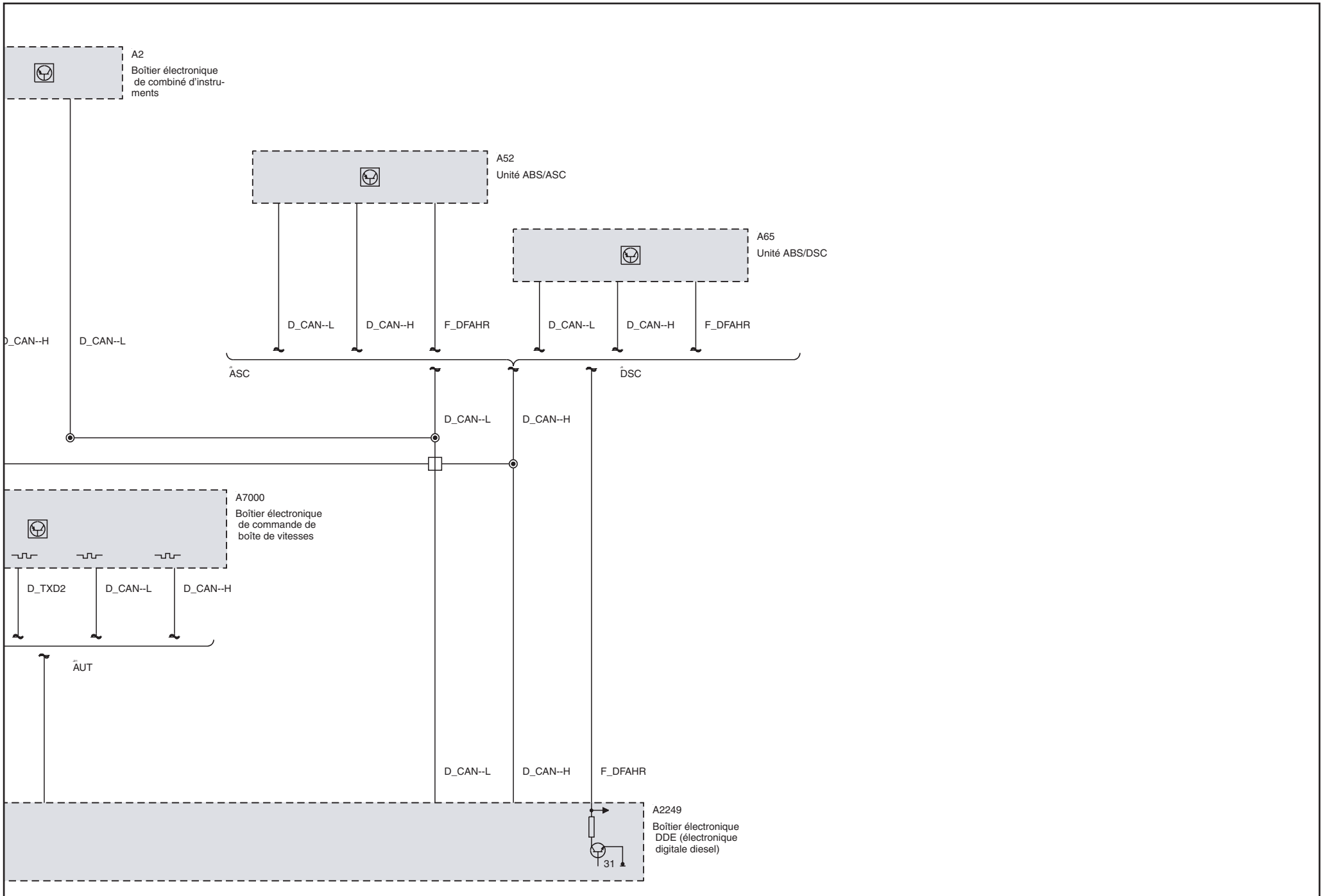

Commande du moteur, régulation du carburant/alimentation (Moteur M57/TU)

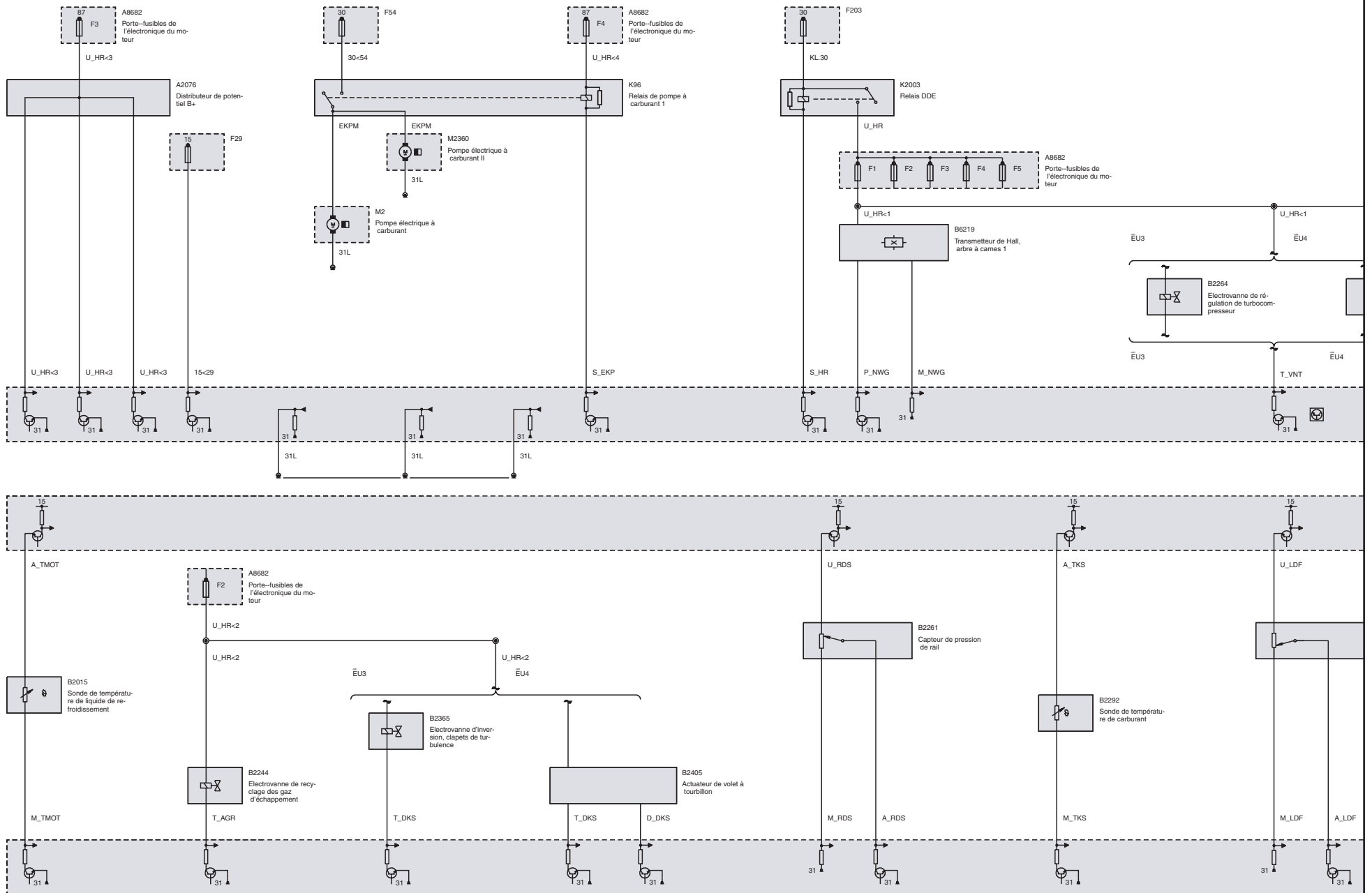



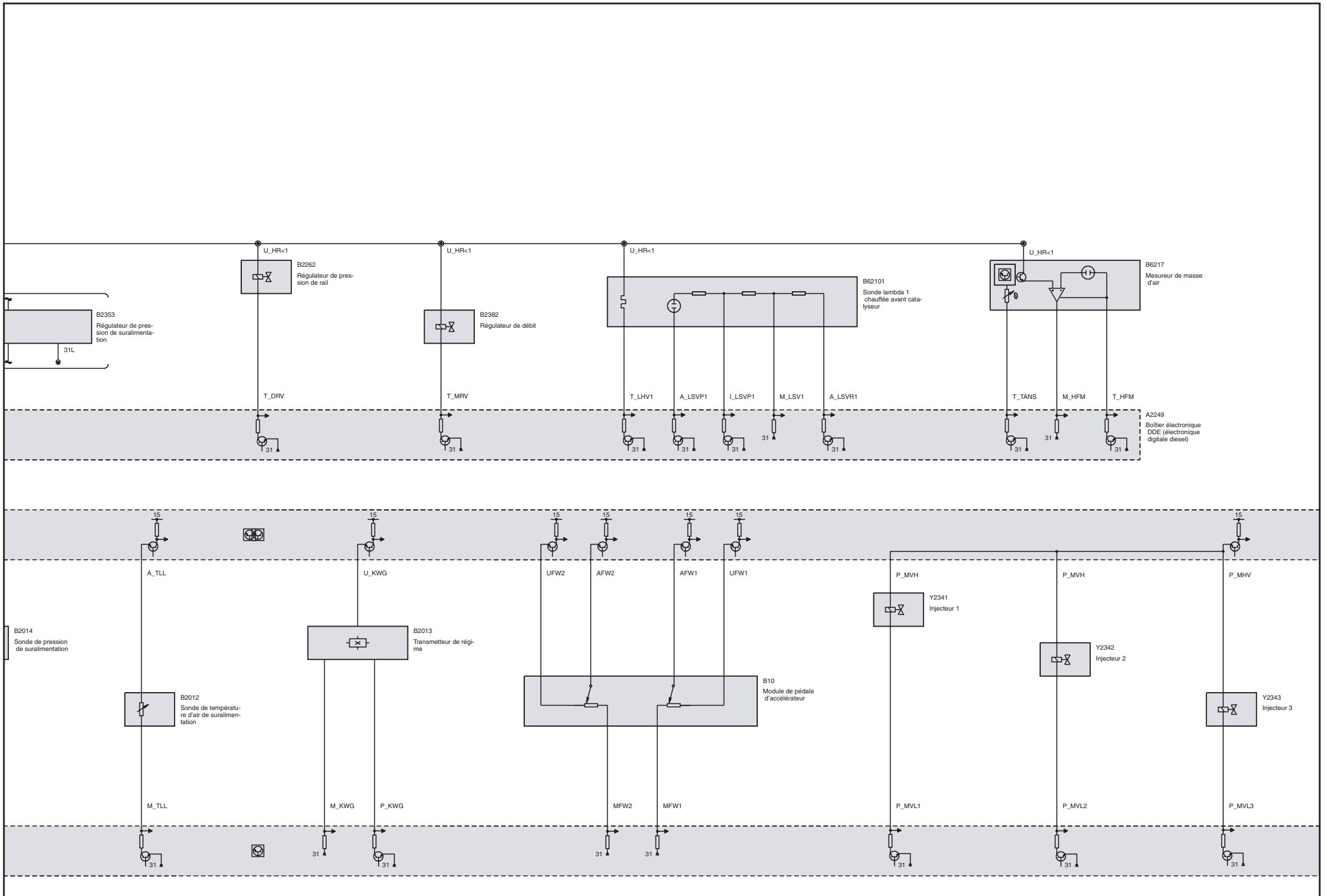

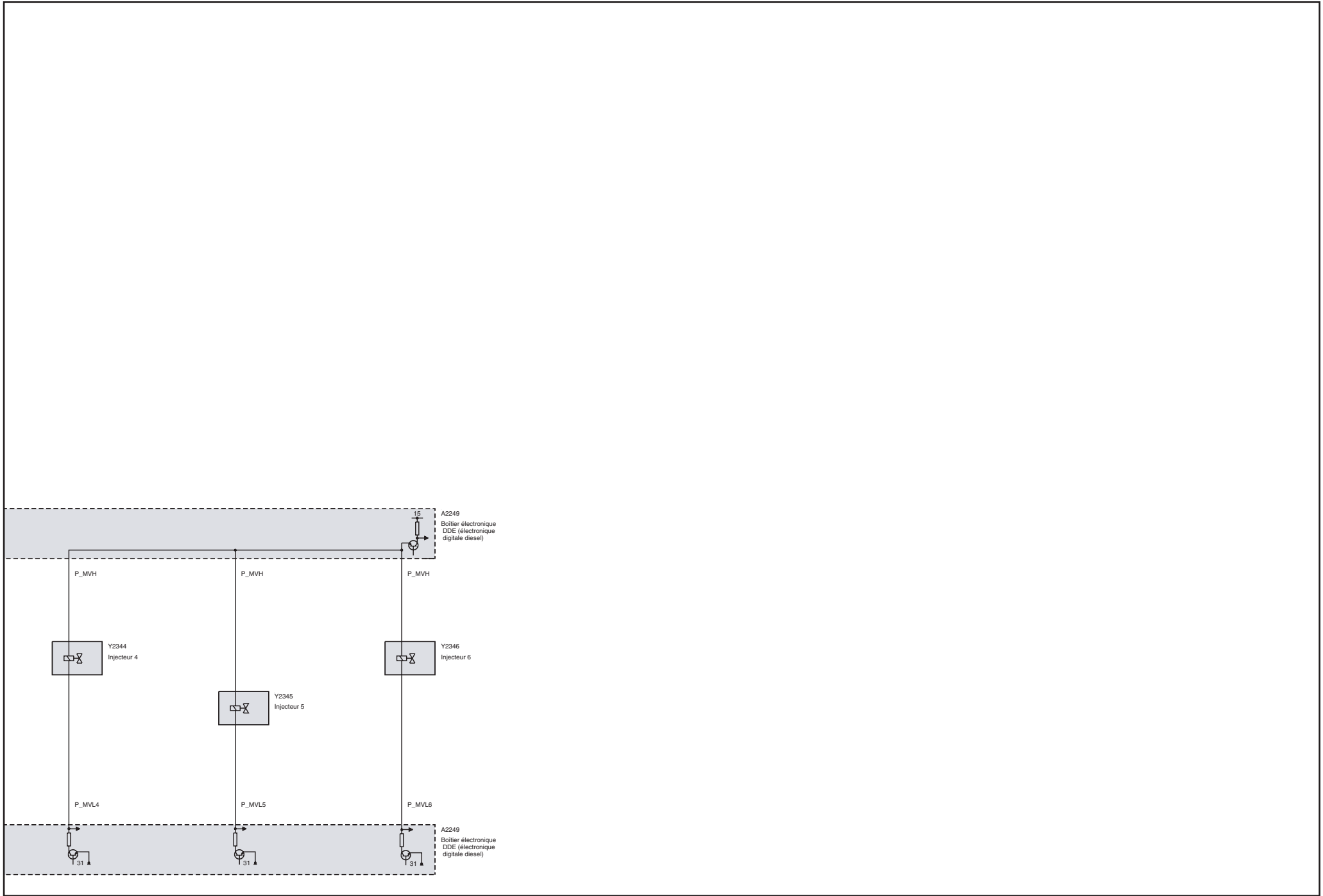

Commande du moteur, fonctions/signaux (Moteur M57/TU)

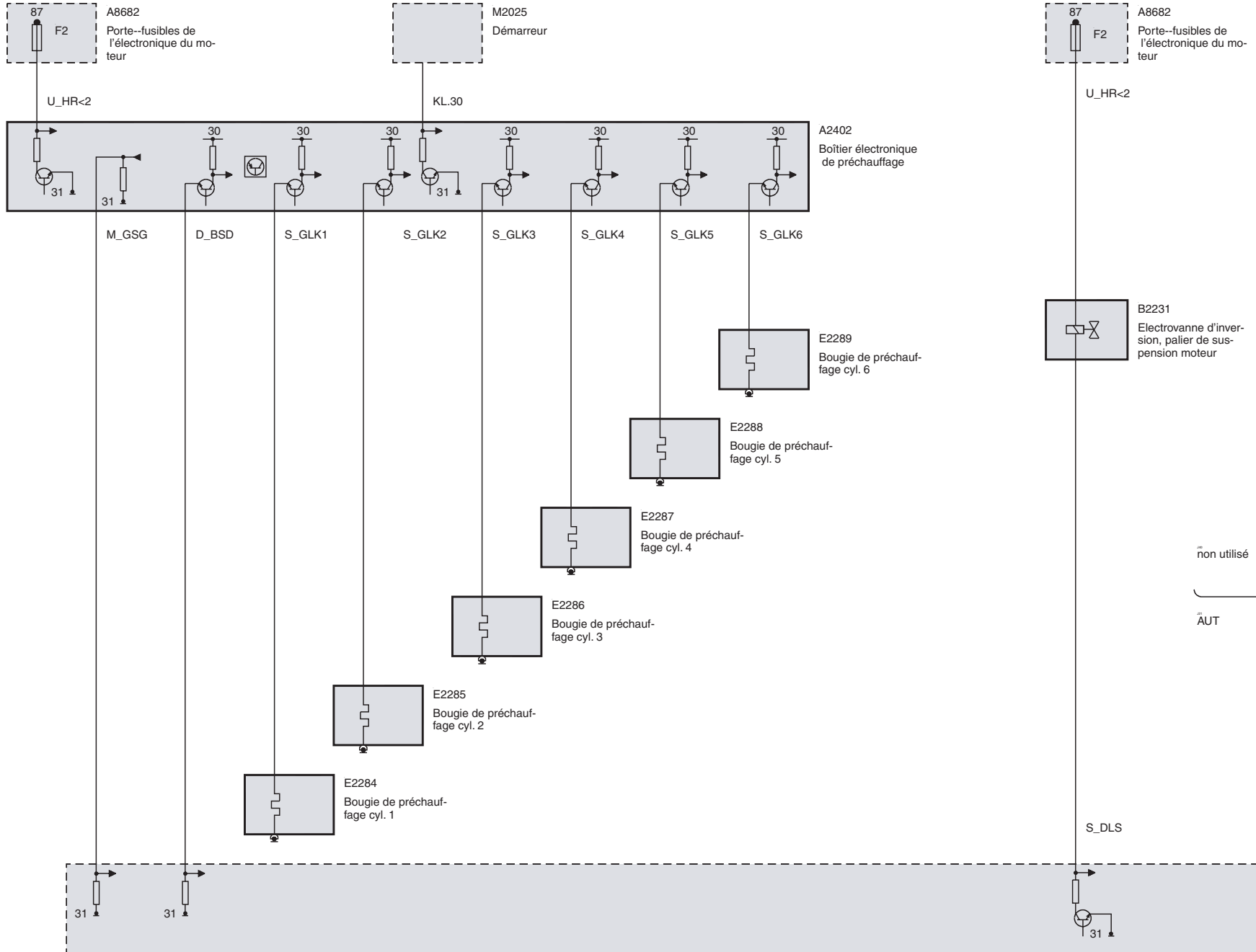

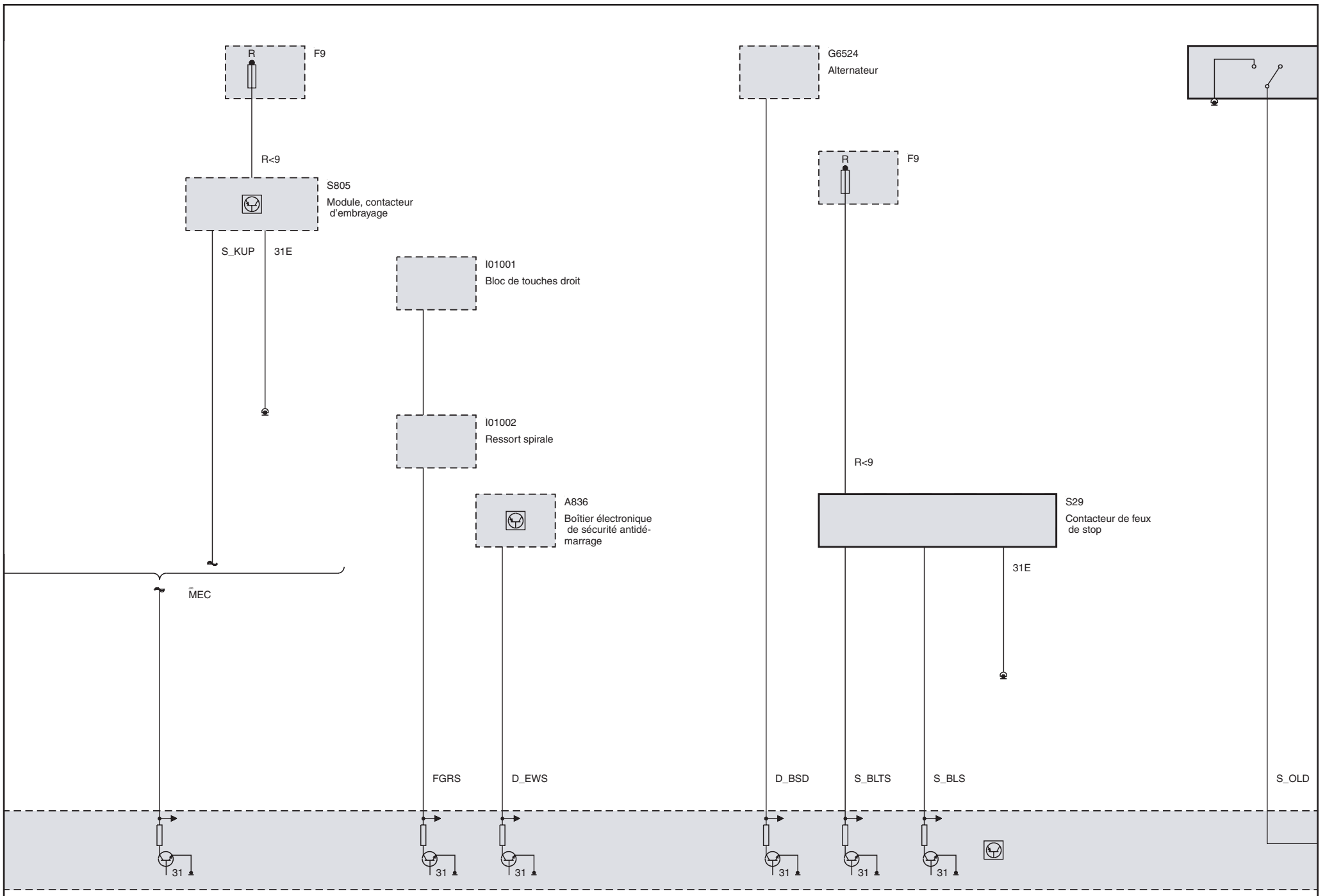

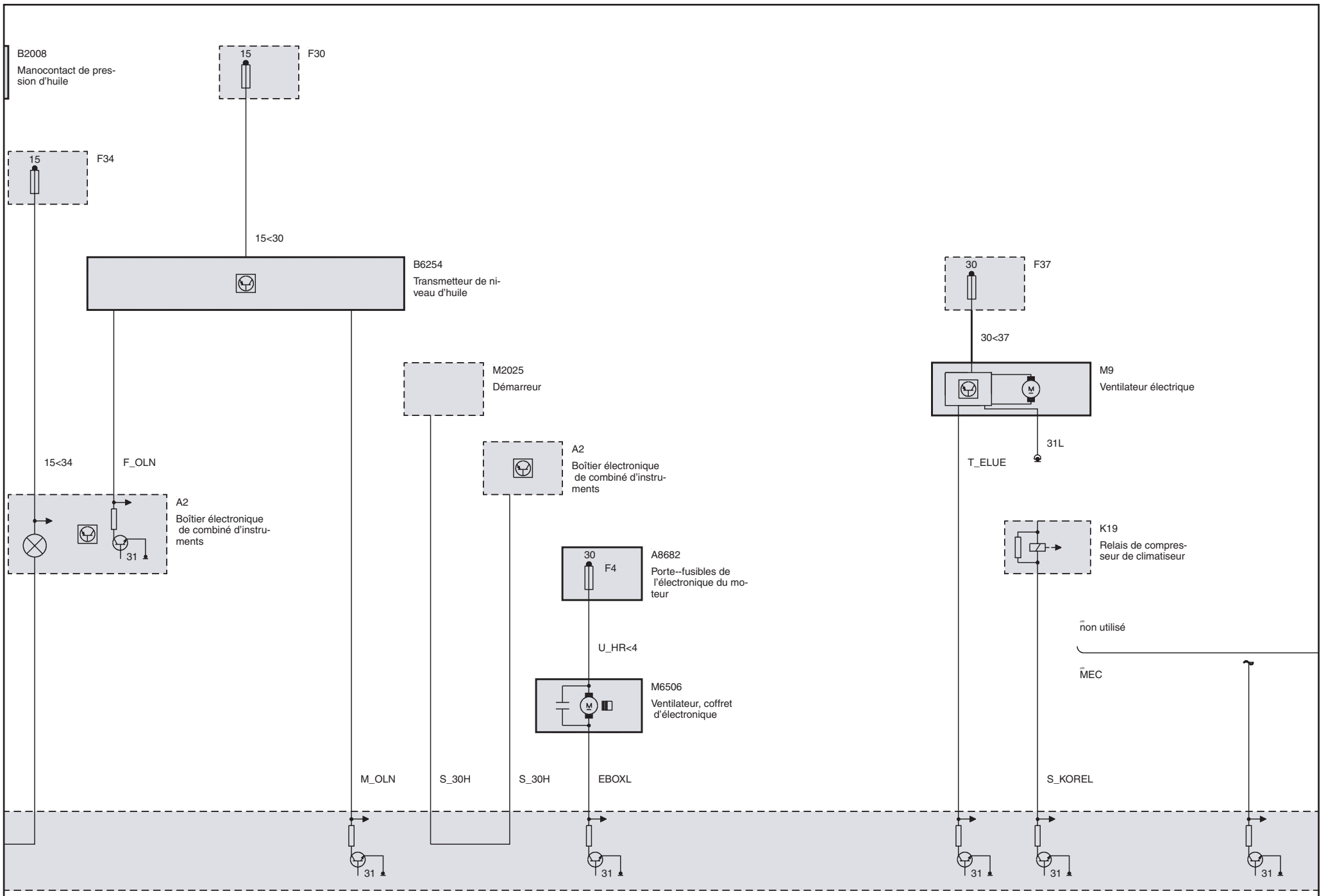

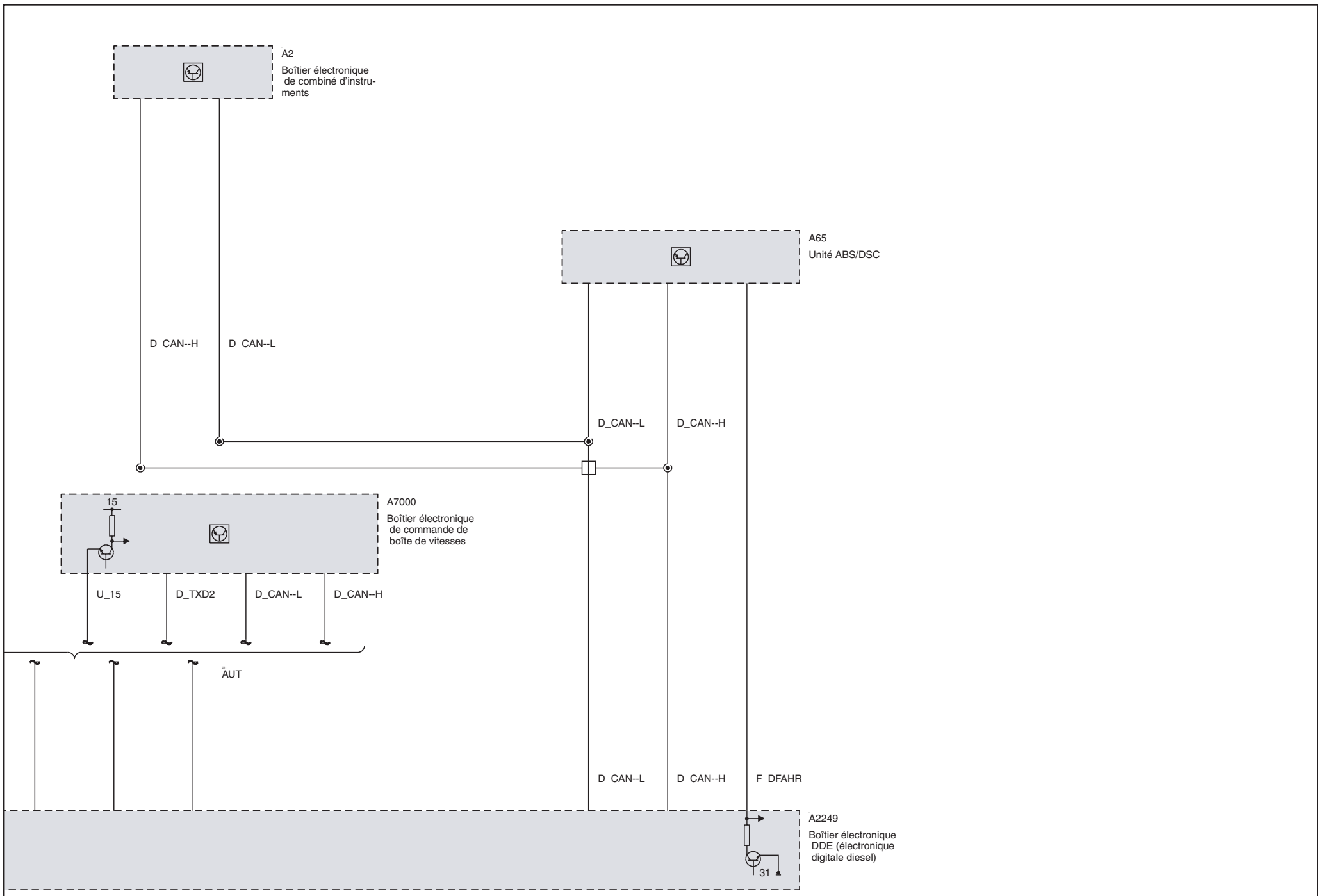

Système de refroidissement moteur

Système de refroidissement moteur (Moteur M47/TU jusqu'à 2003\_03)

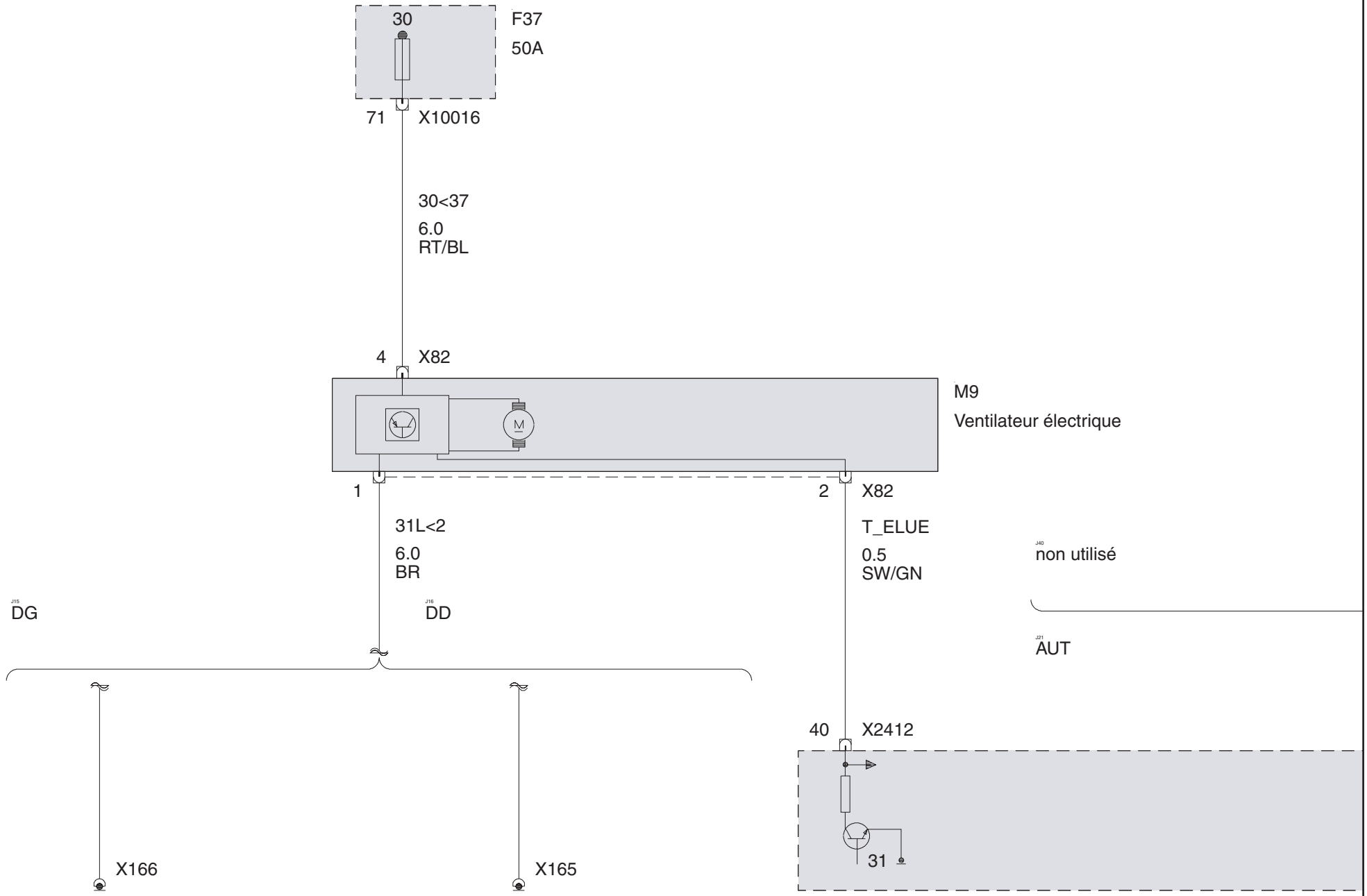

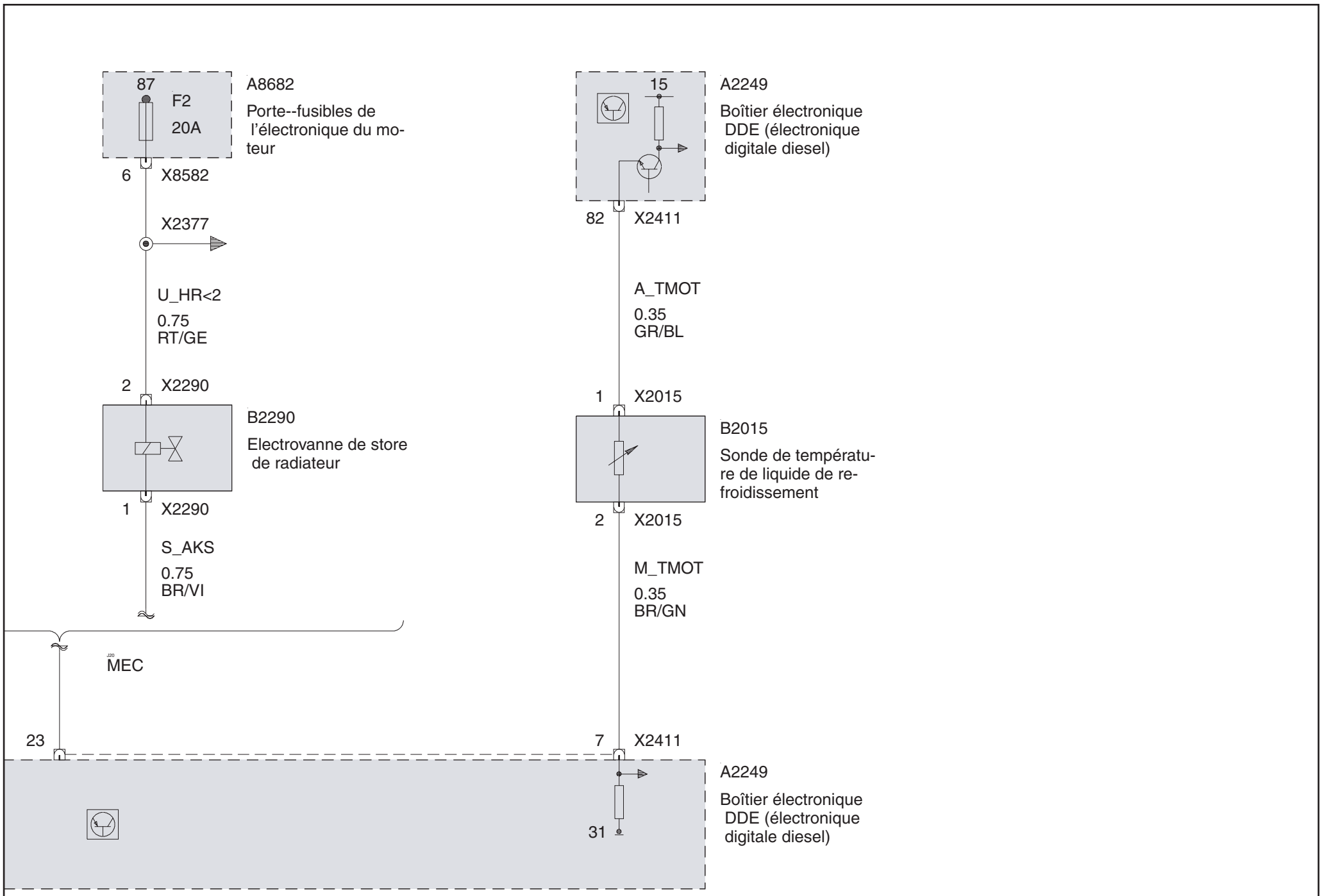



Système de refroidissement moteur (( Berline ou Touring ou Compact ) avec Moteur M47/TU à partir de 2003\_03)

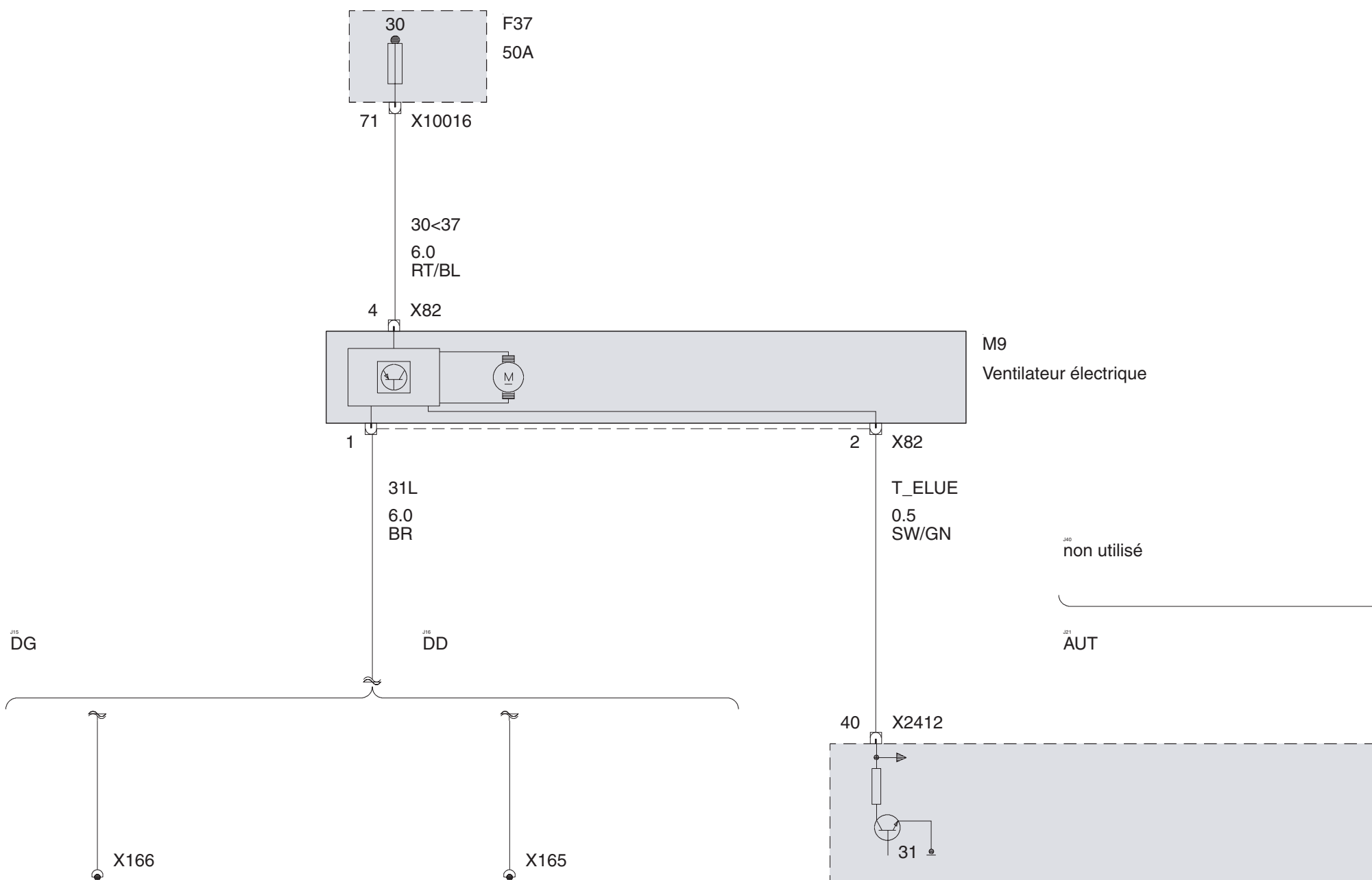

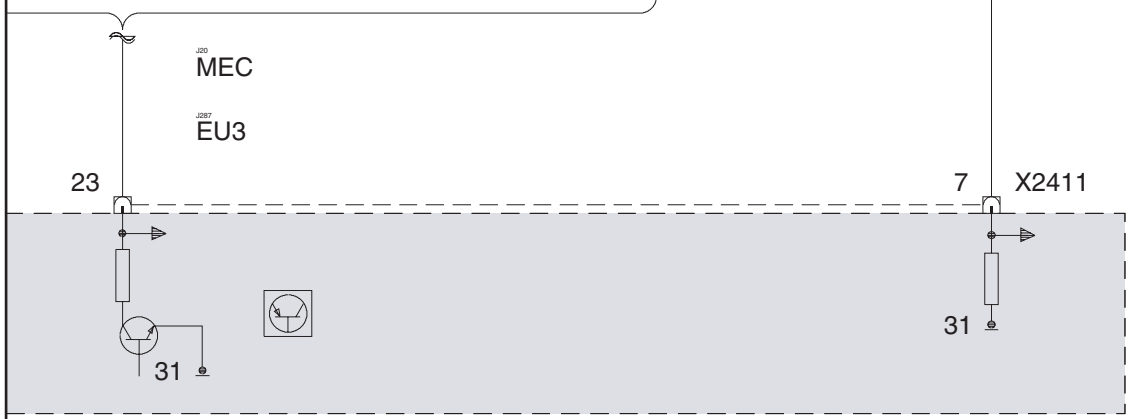
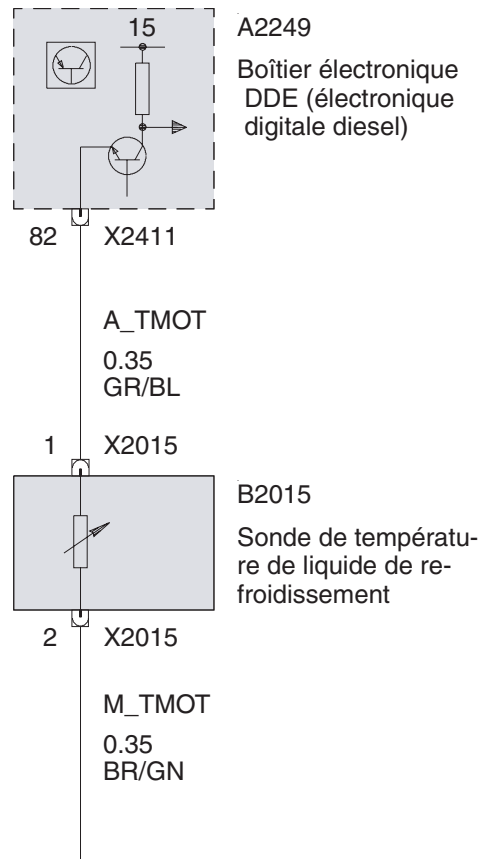
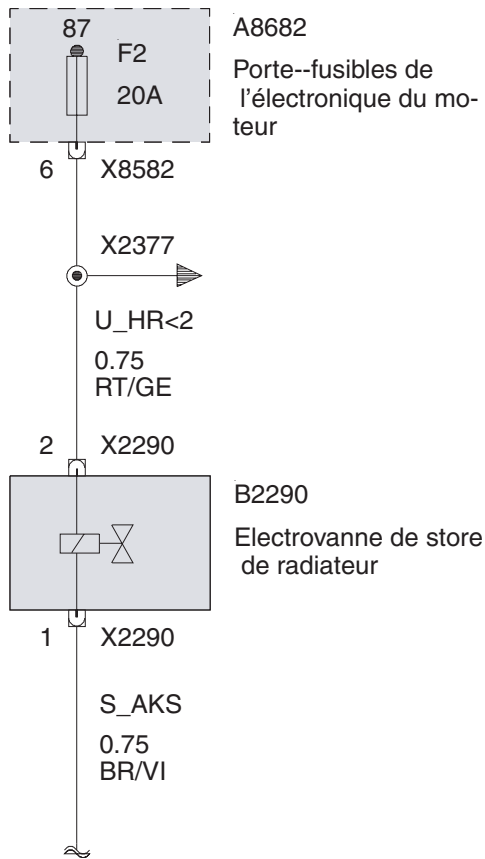

Systeme de refroidissement moteur (Coupé avec Moteur M47/TU à partir de 2003\_03)

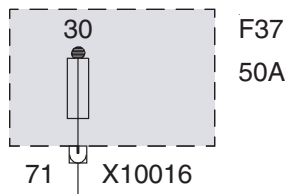

30<37  
6.0  
RT/BL

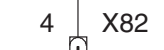

1  
31L  
6.0  
BR

2 X82  
T\_ELUE  
0.5  
SW/GN

<sup>J40</sup>  
non utilisé

<sup>J15</sup>  
DG

<sup>J16</sup>  
DD

<sup>J21</sup>  
AUT

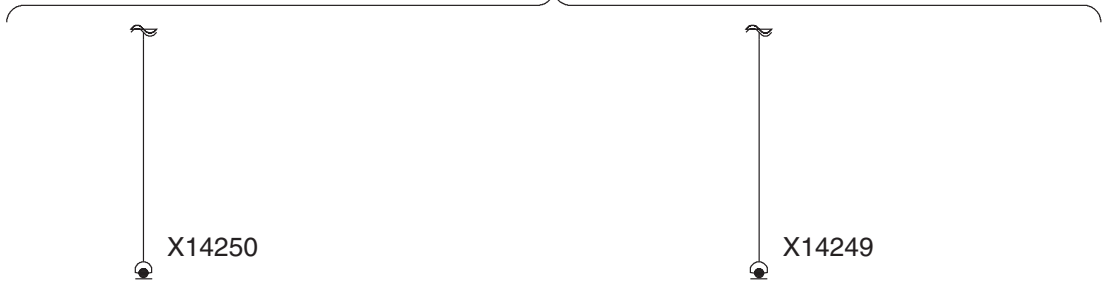

40 X2412



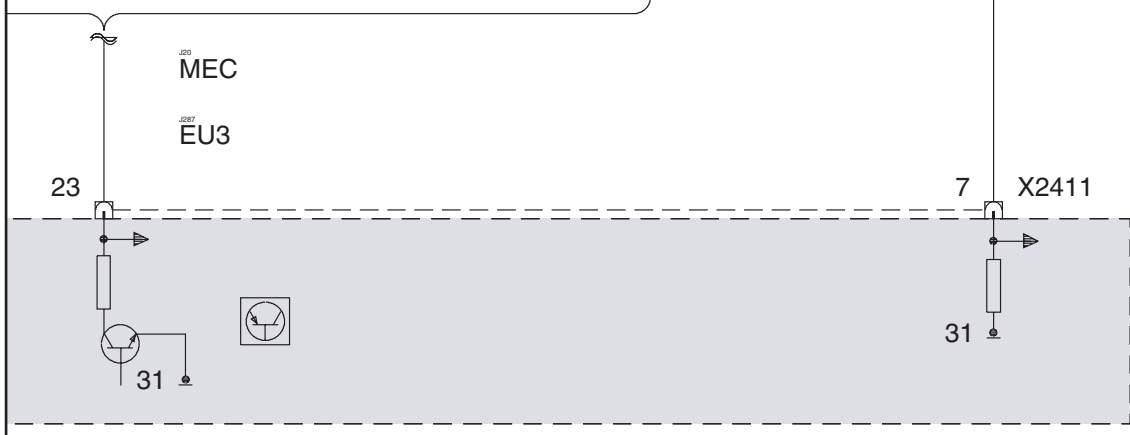
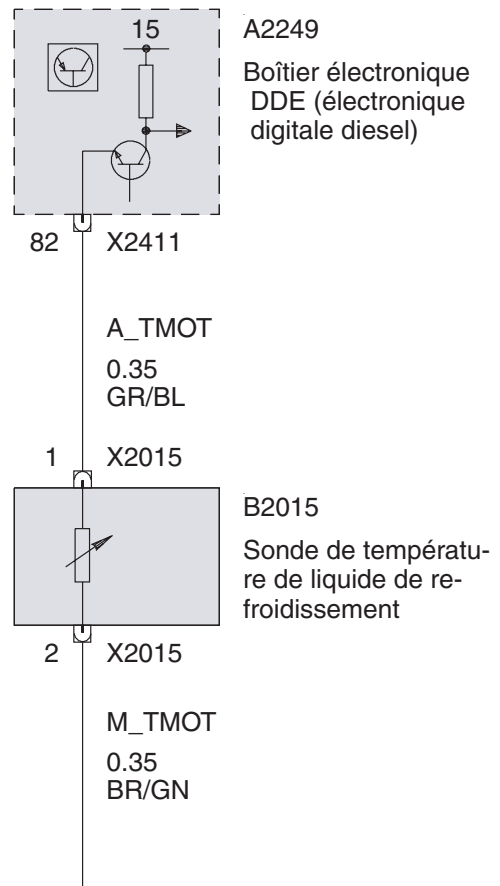
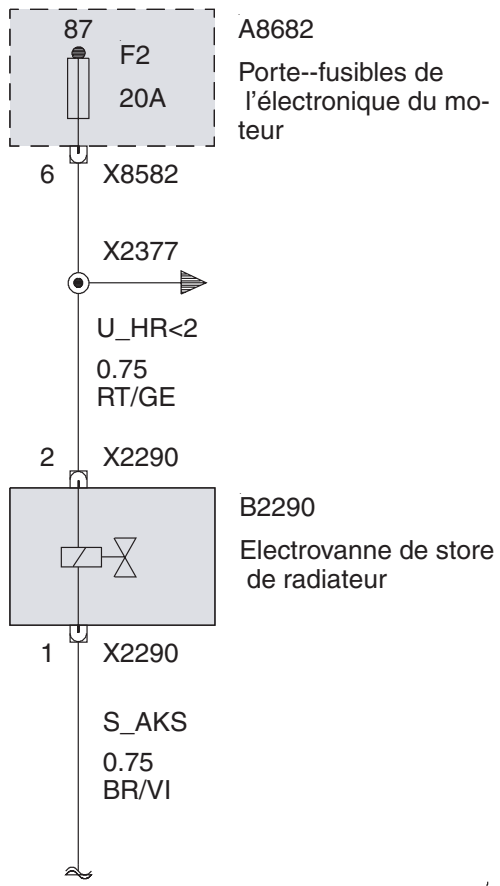

Système de refroidissement moteur (( Berline ou Touring ou Compact ) avec Moteur M57/TU)

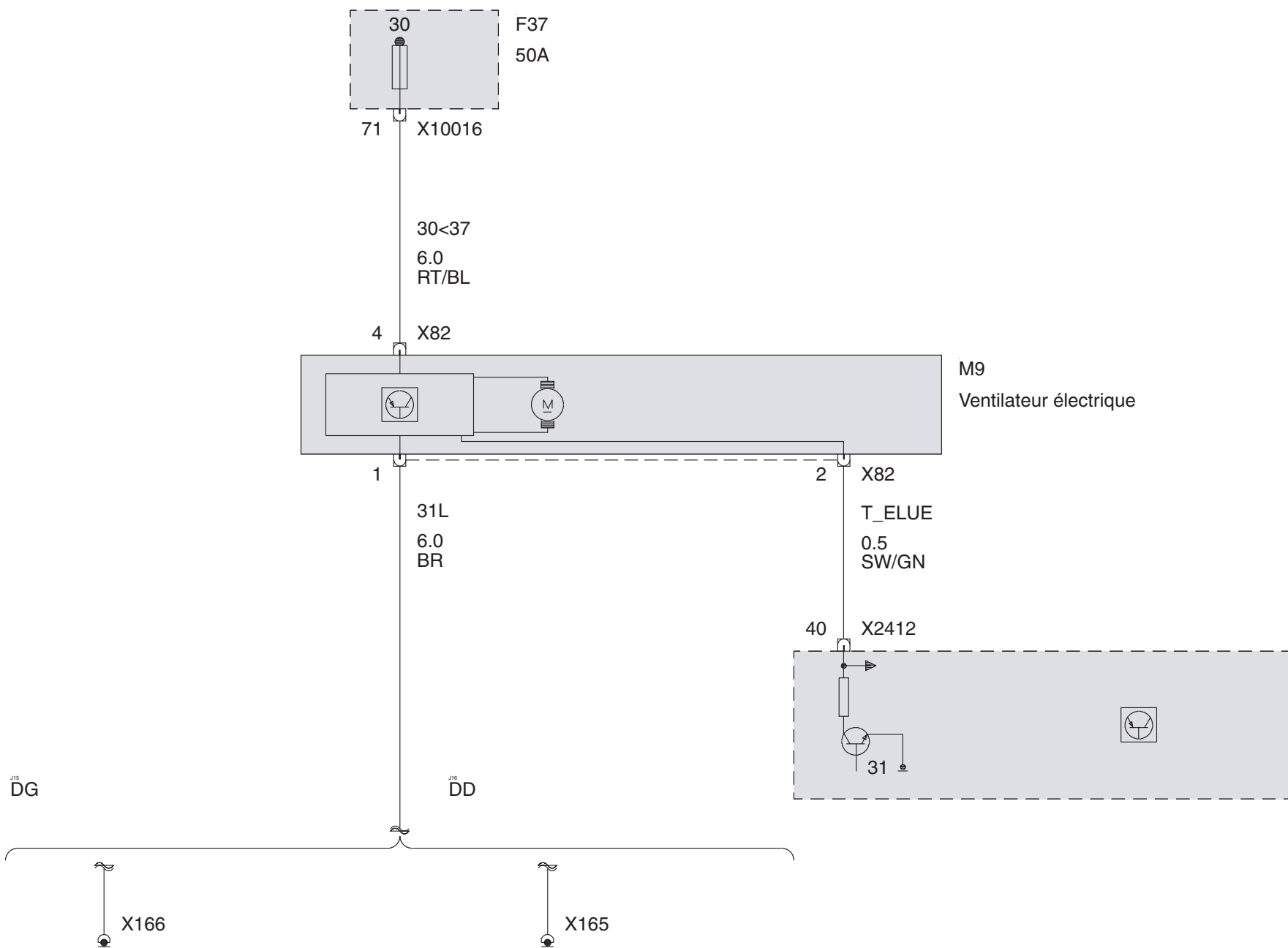

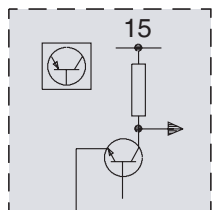

A2249  
Boîtier électronique  
DDE (électronique  
digitale diesel)

82 X2411

A\_TMOT  
0.35  
GR/BL

1 X2015

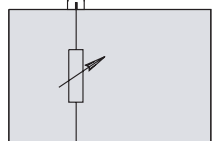

B2015  
Sonde de tempé-  
rature de liqui-  
de de re-  
froidissement

2 X2015

M\_TMOT  
0.35  
BR/GN

7 X2411

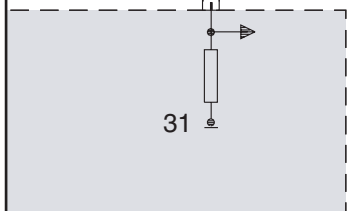

A2249  
Boîtier électronique  
DDE (électronique  
digitale diesel)

Système de refroidissement moteur (Coupé avec Moteur M57/TU)

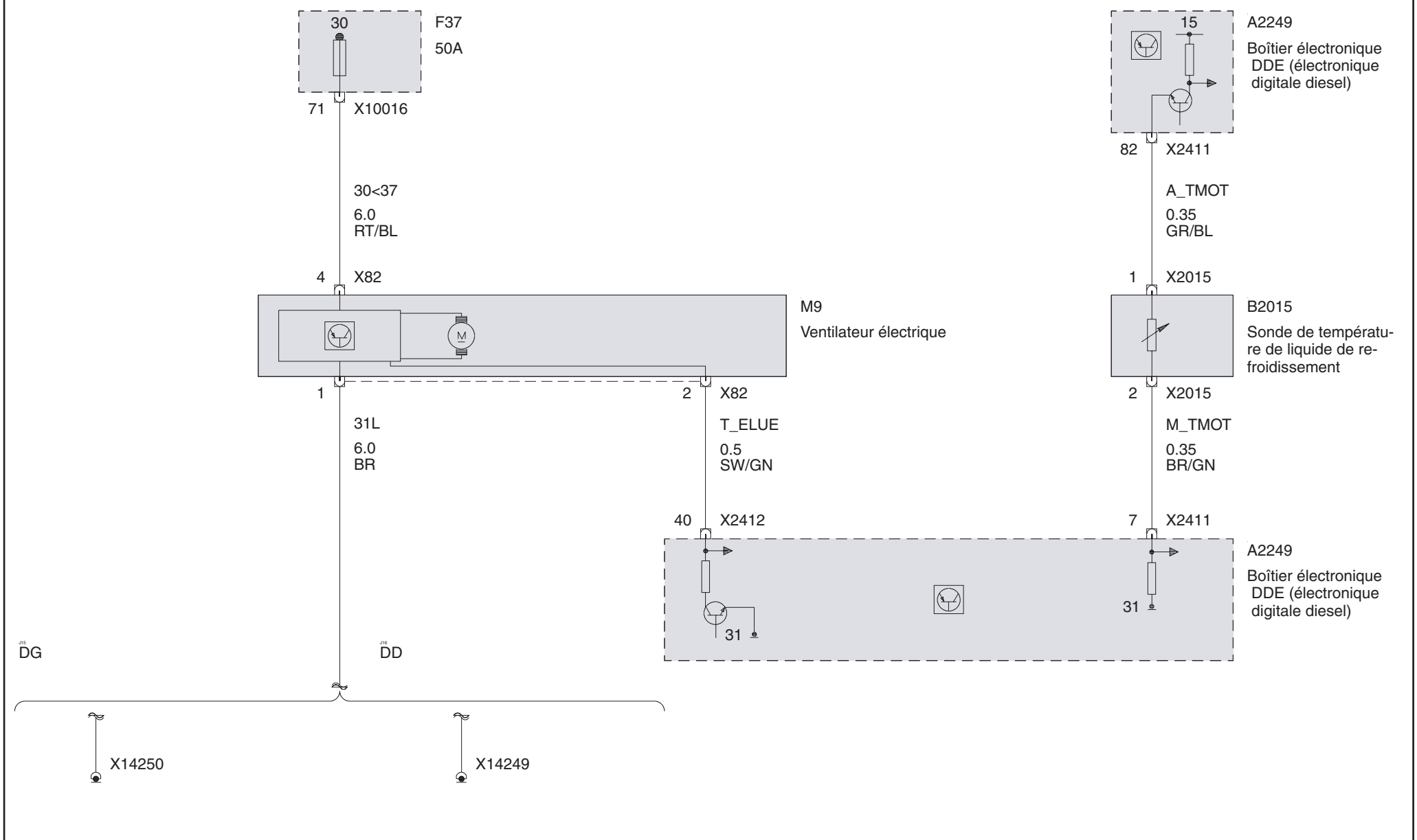

Mesure du régime moteur  
Saisie du régime moteur (Moteur M47/TU)

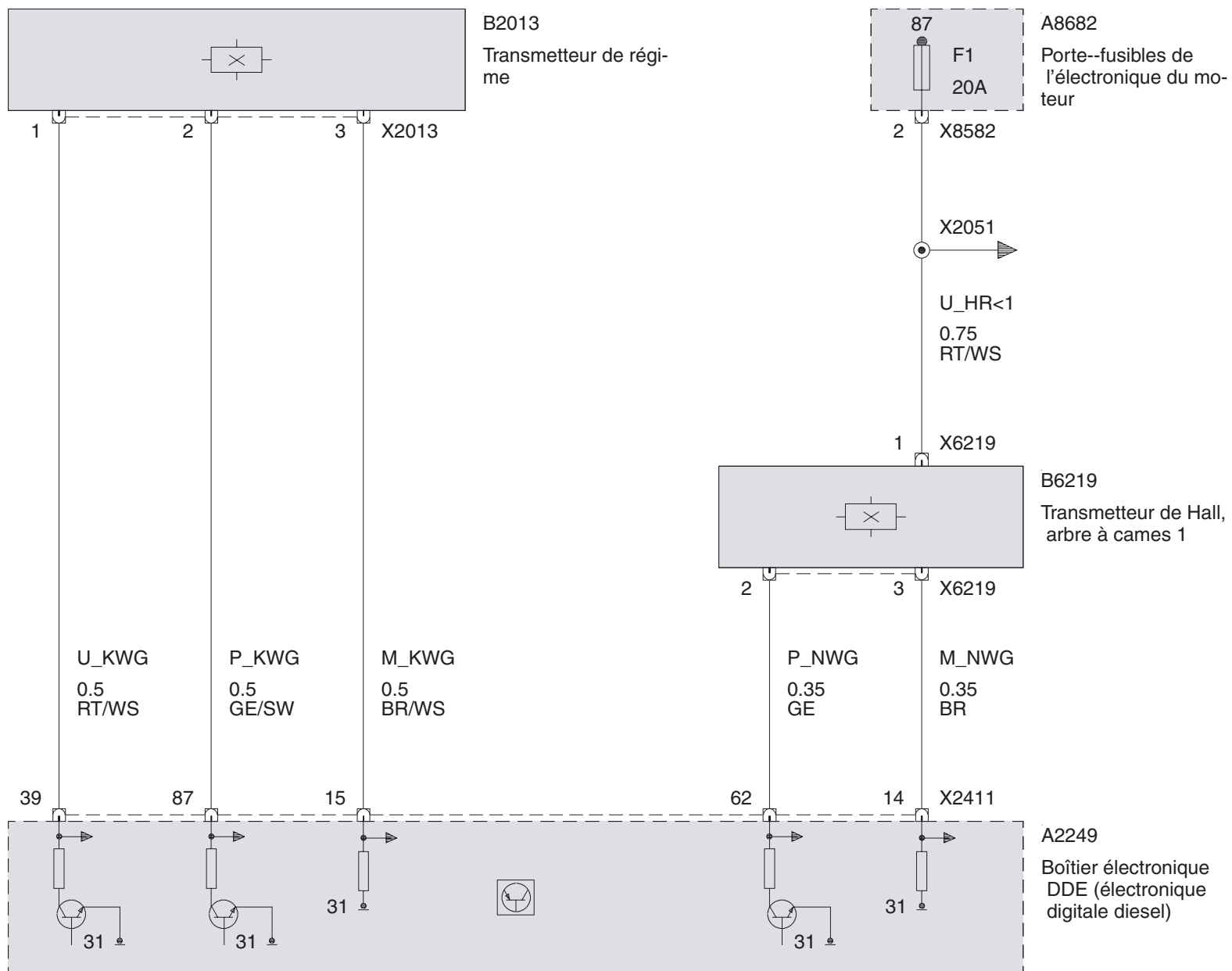



Saisie du régime moteur (Moteur M57/TU)

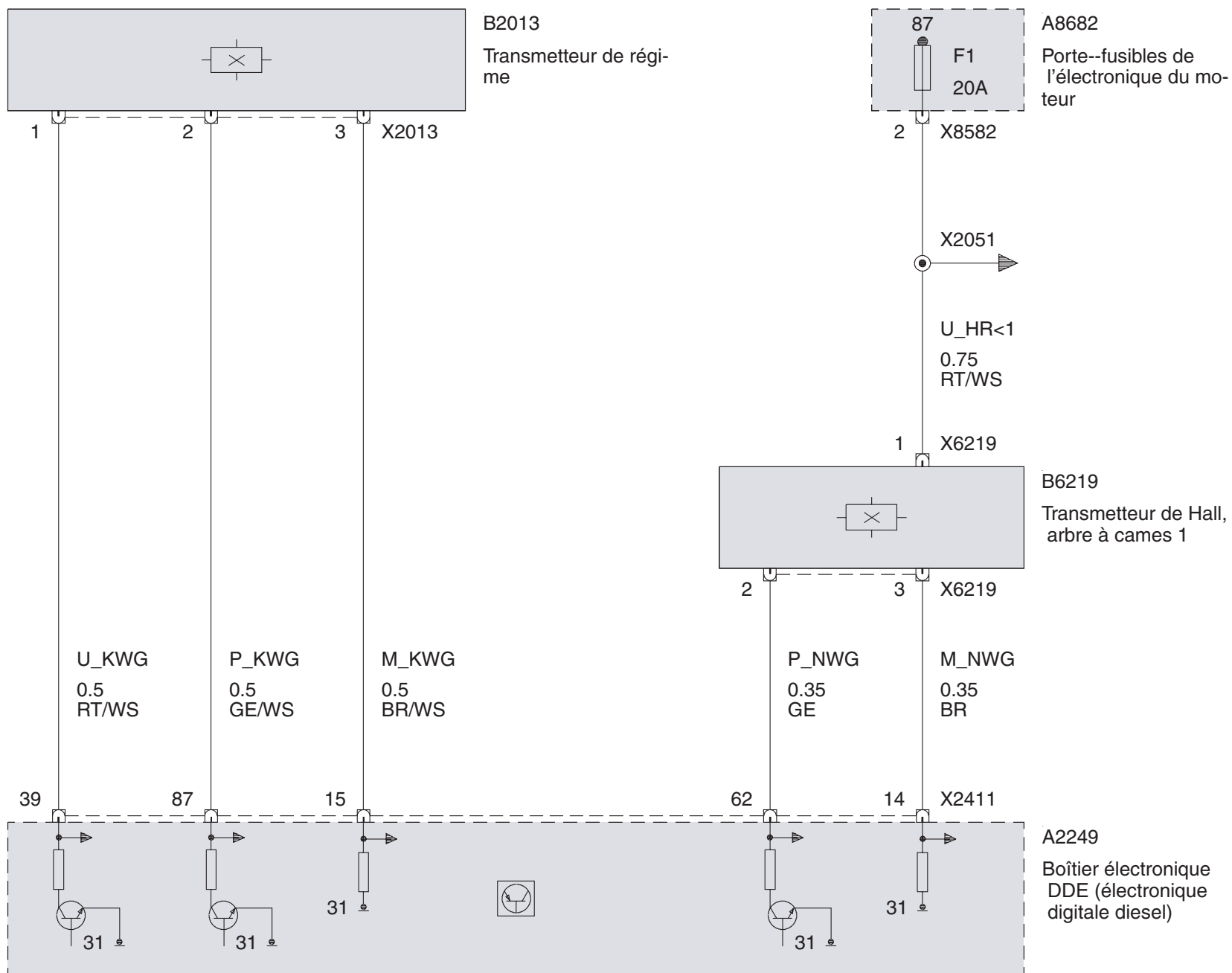

Alimentation en air

Débitmètre massique à film chaud (Moteur M47/TU jusque 2003\_03)

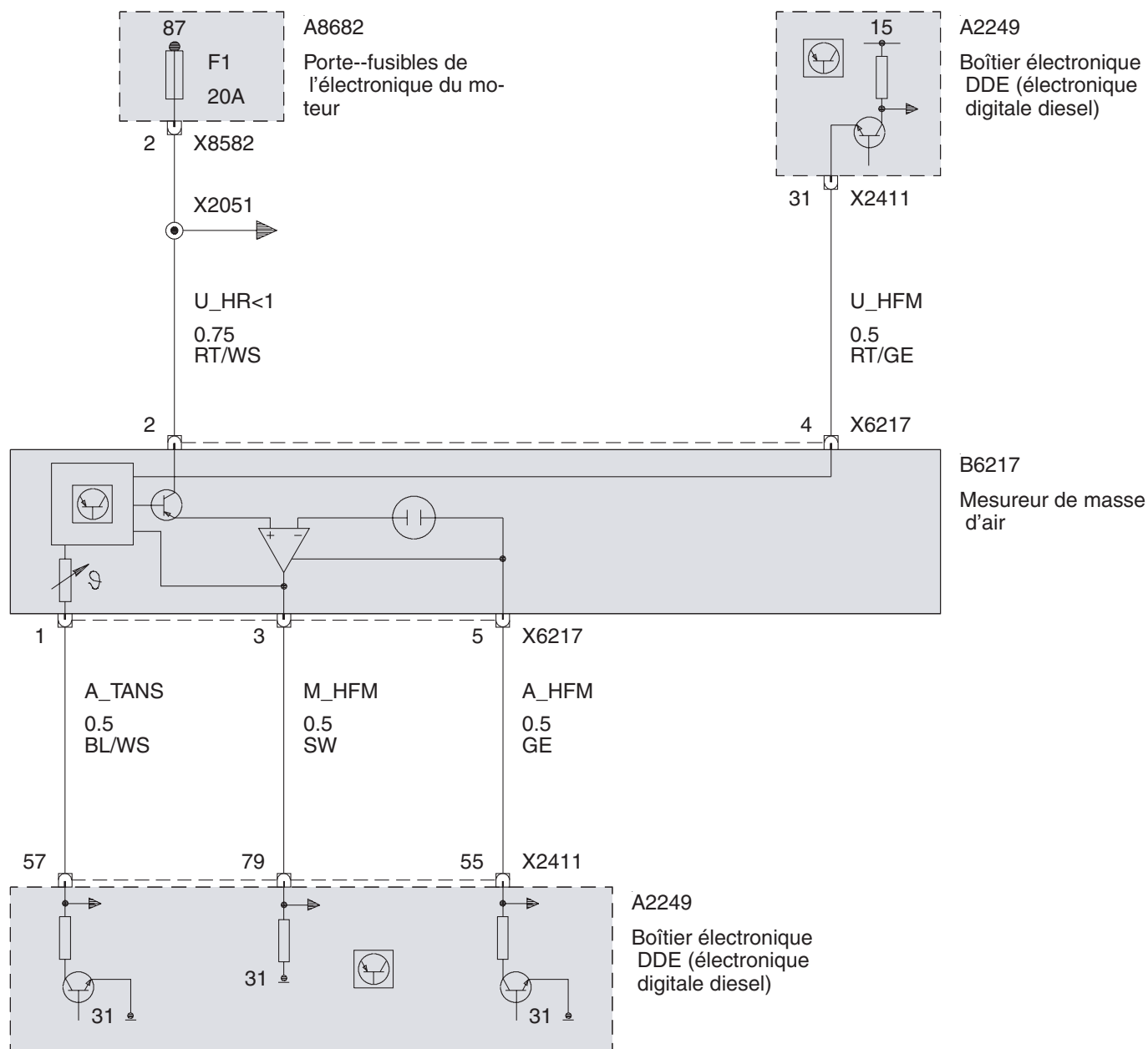

Débitmètre massique à film chaud (Moteur M47/TU sans DDE Electronique numérique diesel UE4 à partir de 2003\_03)

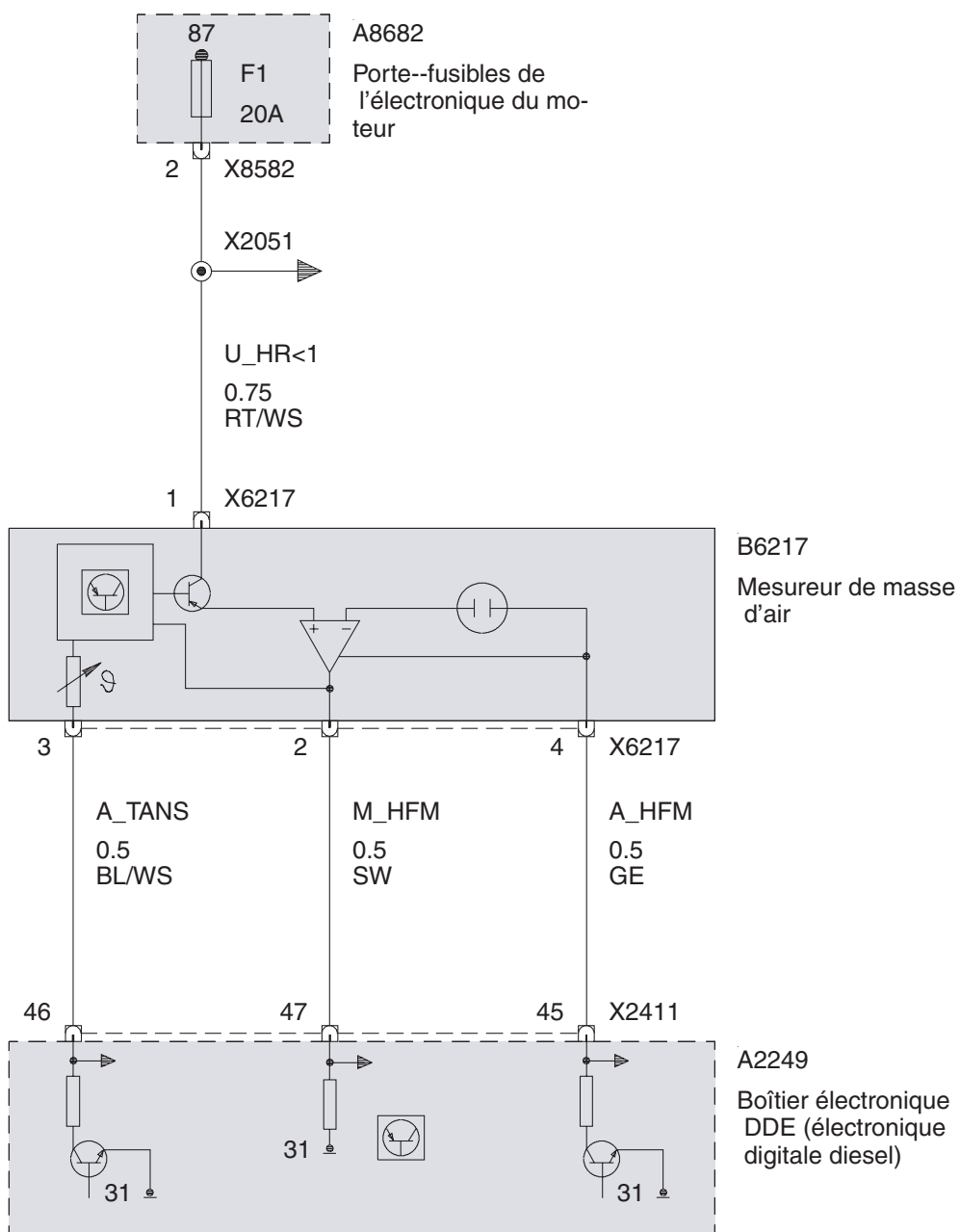

Débitmètre massique à film chaud (Moteur M47/TU avec DDE Electronique numérique diesel UE4 à partir de 2003\_03)

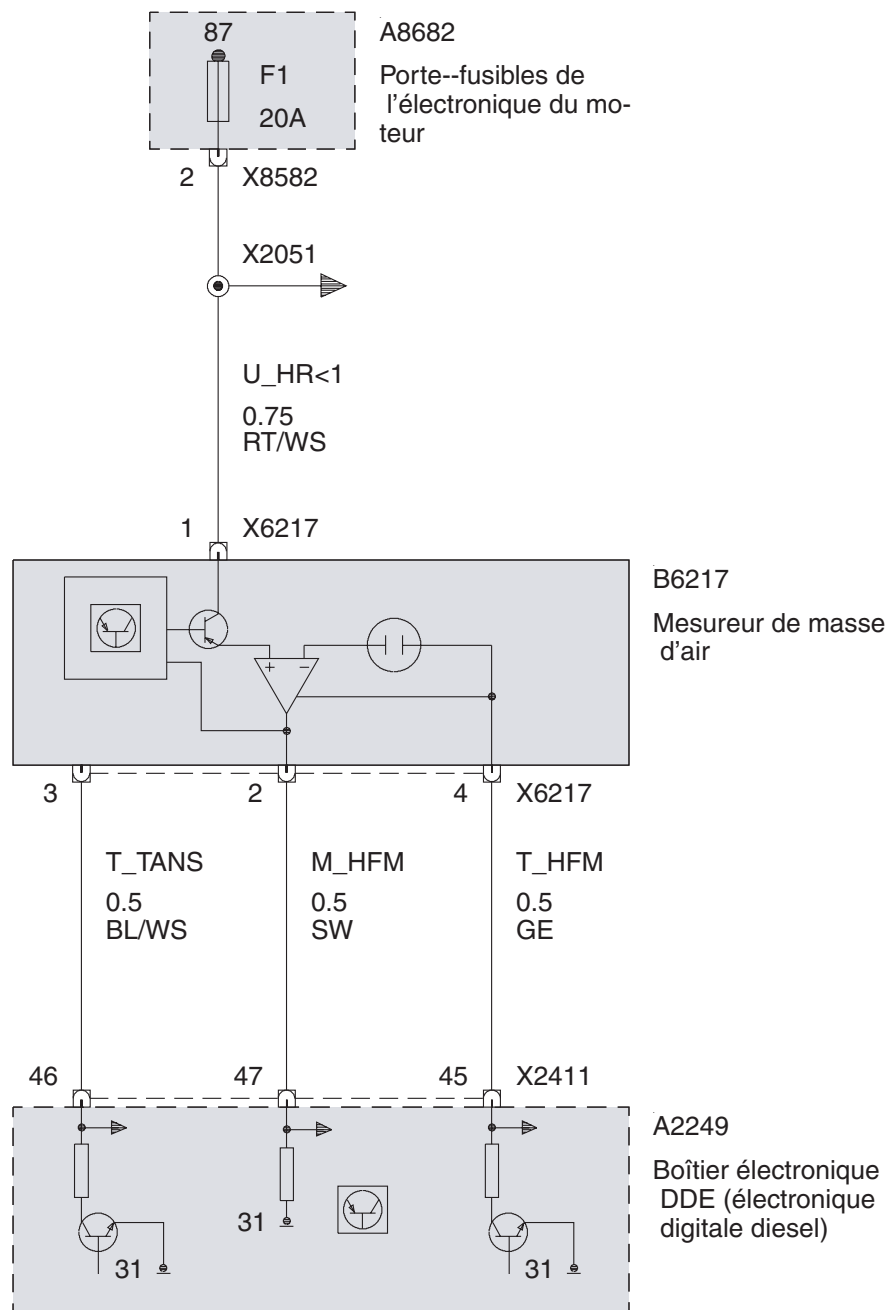

Débitmètre massique à film chaud (Moteur M57/TU)

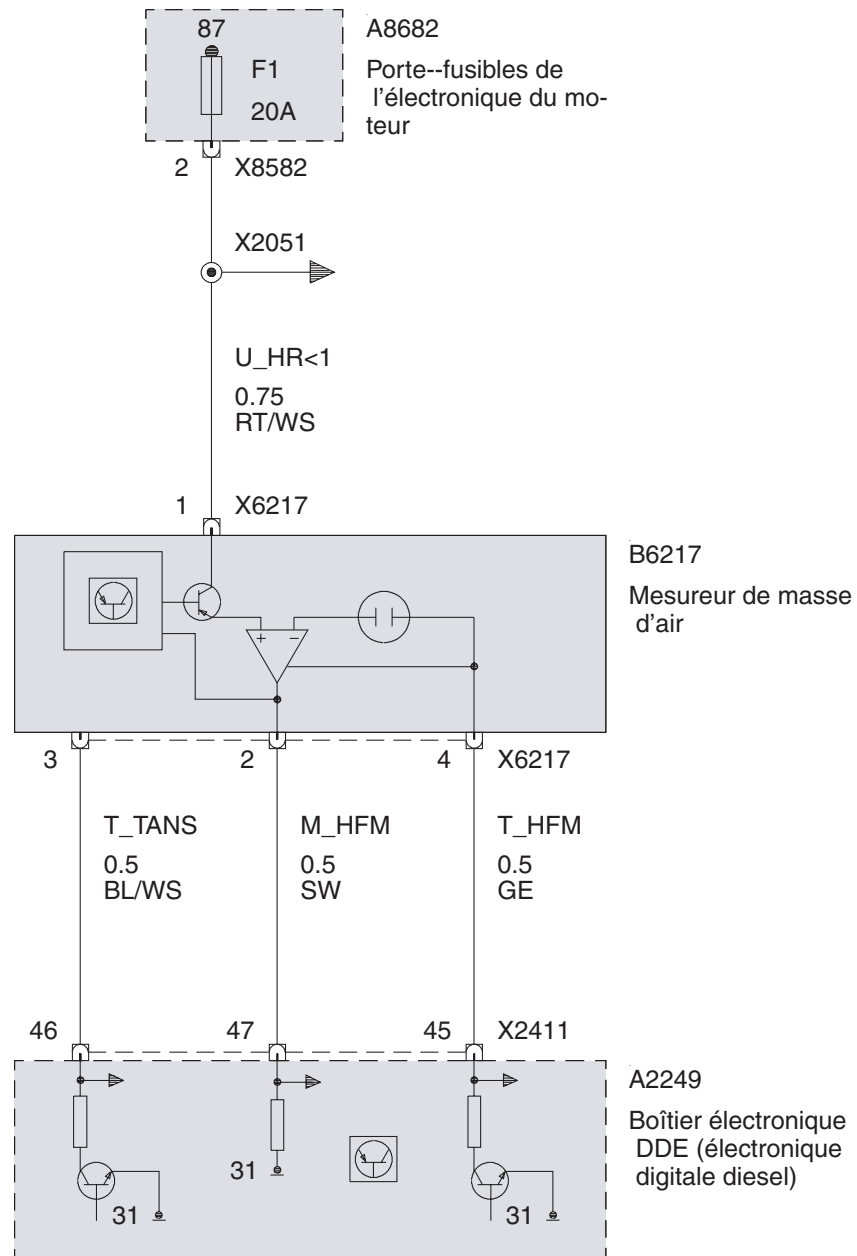

Actionneur clapets giratoires (Moteur M47/TU)

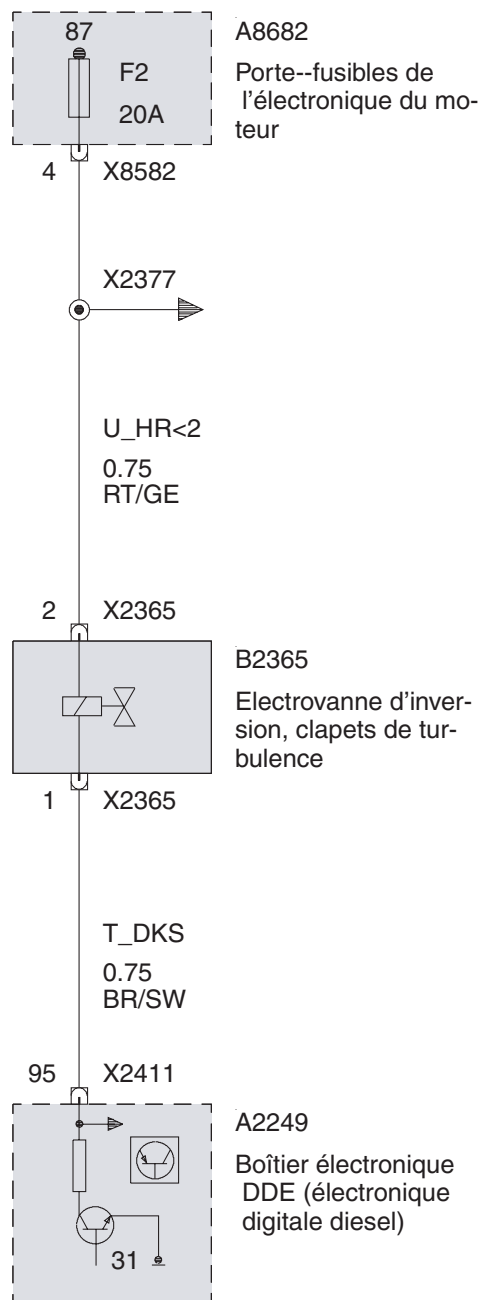

Actionneur clapets giratoires (Moteur M57/TU sans DDE Electronique numérique diesel UE4)

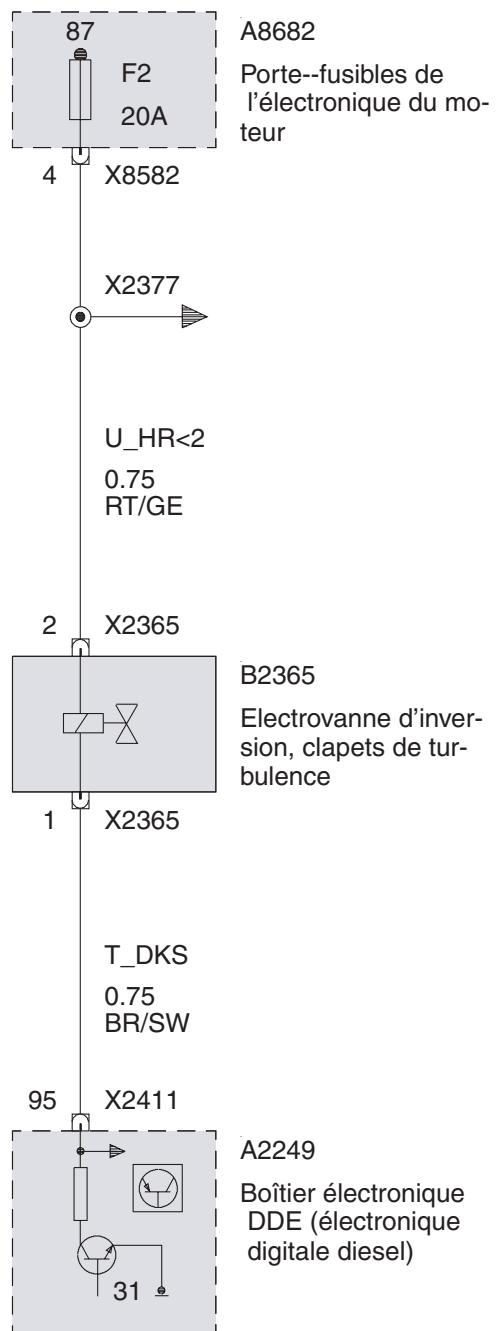

Actionneur clapets giratoires (Moteur M57/TU avec DDE Electronique numérique diesel UE4)

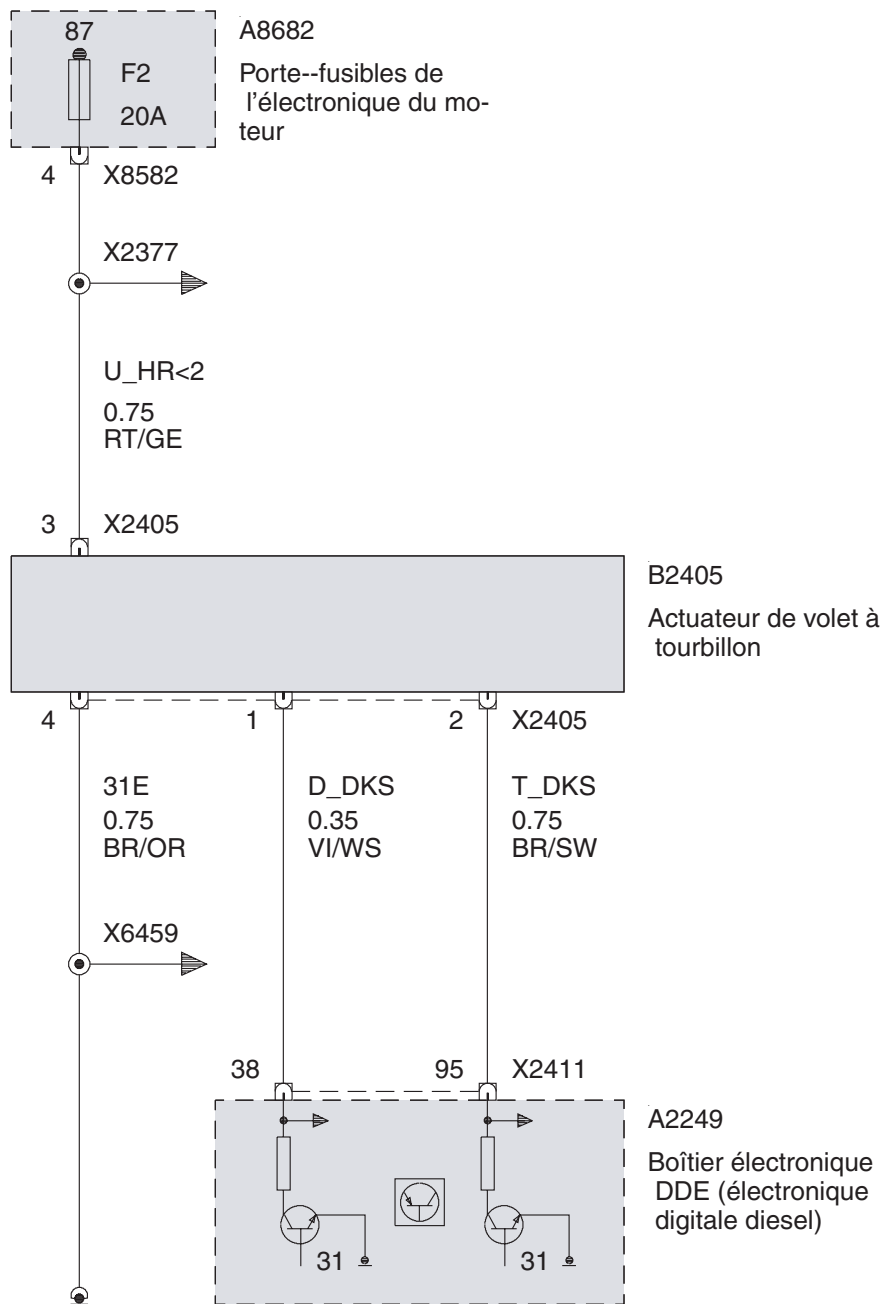



### Régulation de la pression de suralimentation

Régulation de la pression de suralimentation (Moteur M47/TU sans DDE Electronique numérique diesel UE4)

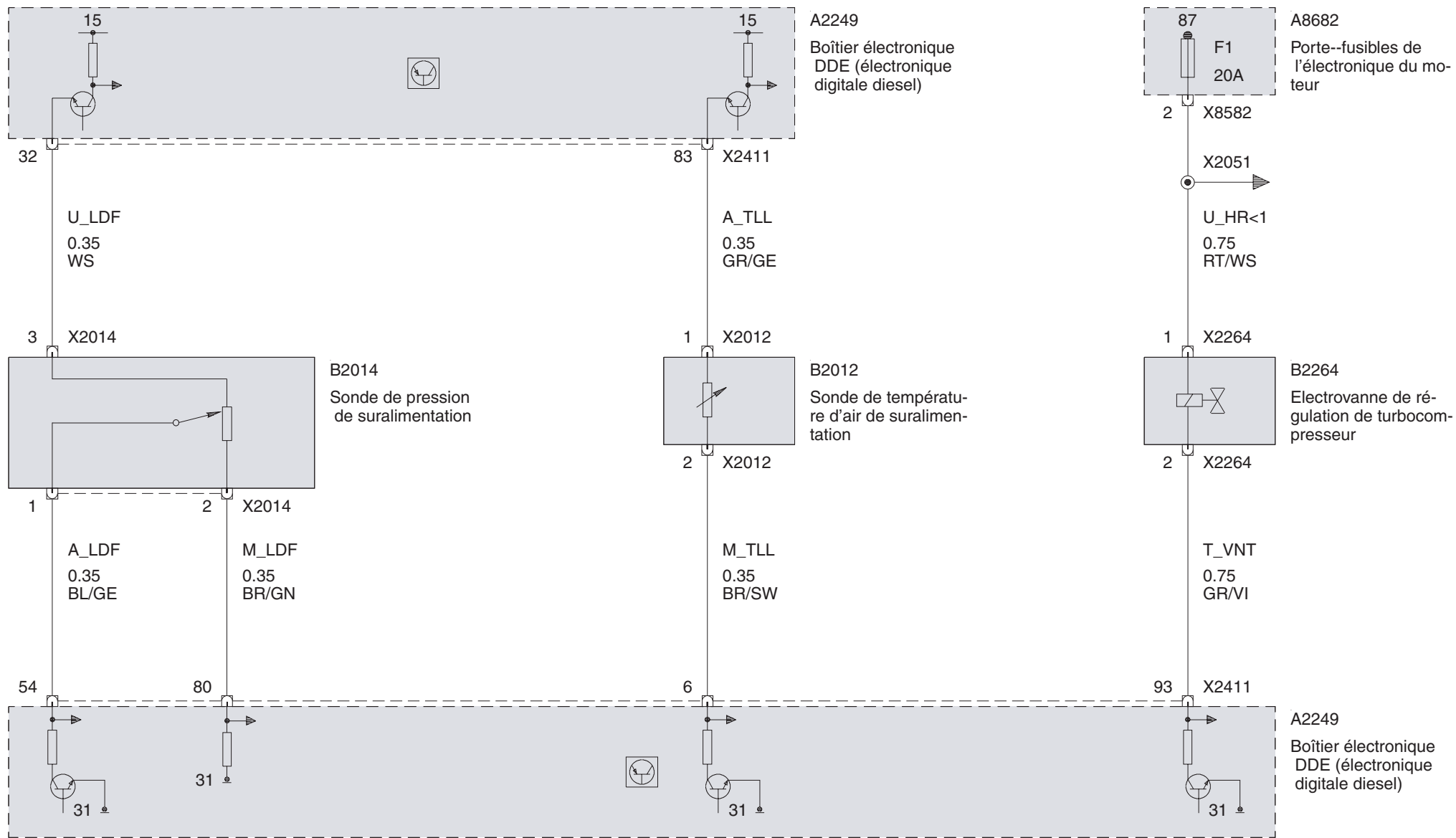

Régulation de la pression de suralimentation (Moteur M57/TU sans DDE Electronique numérique diesel UE4)

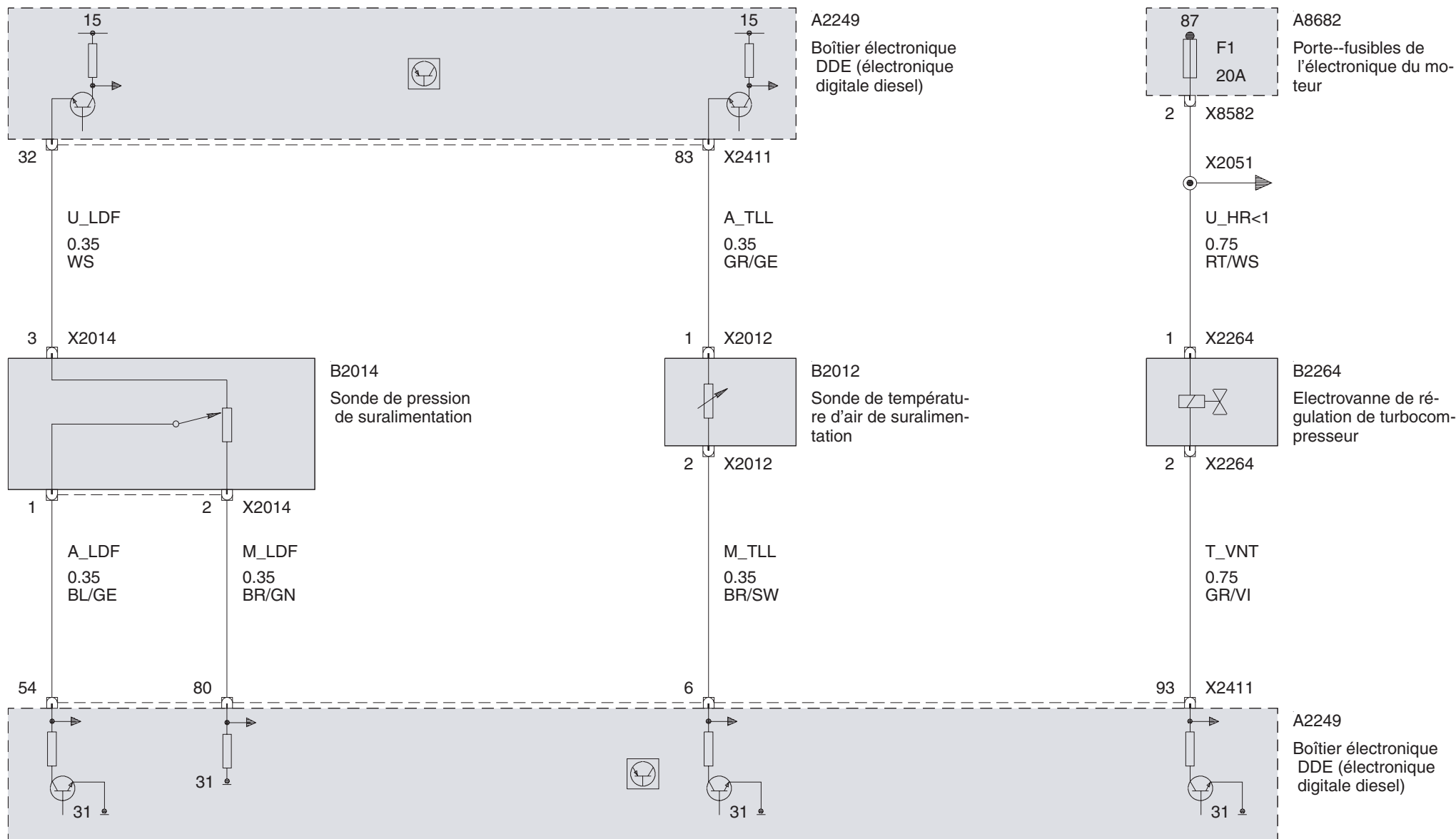

Régulation de la pression de suralimentation (DDE Electronique numérique diesel UE4)

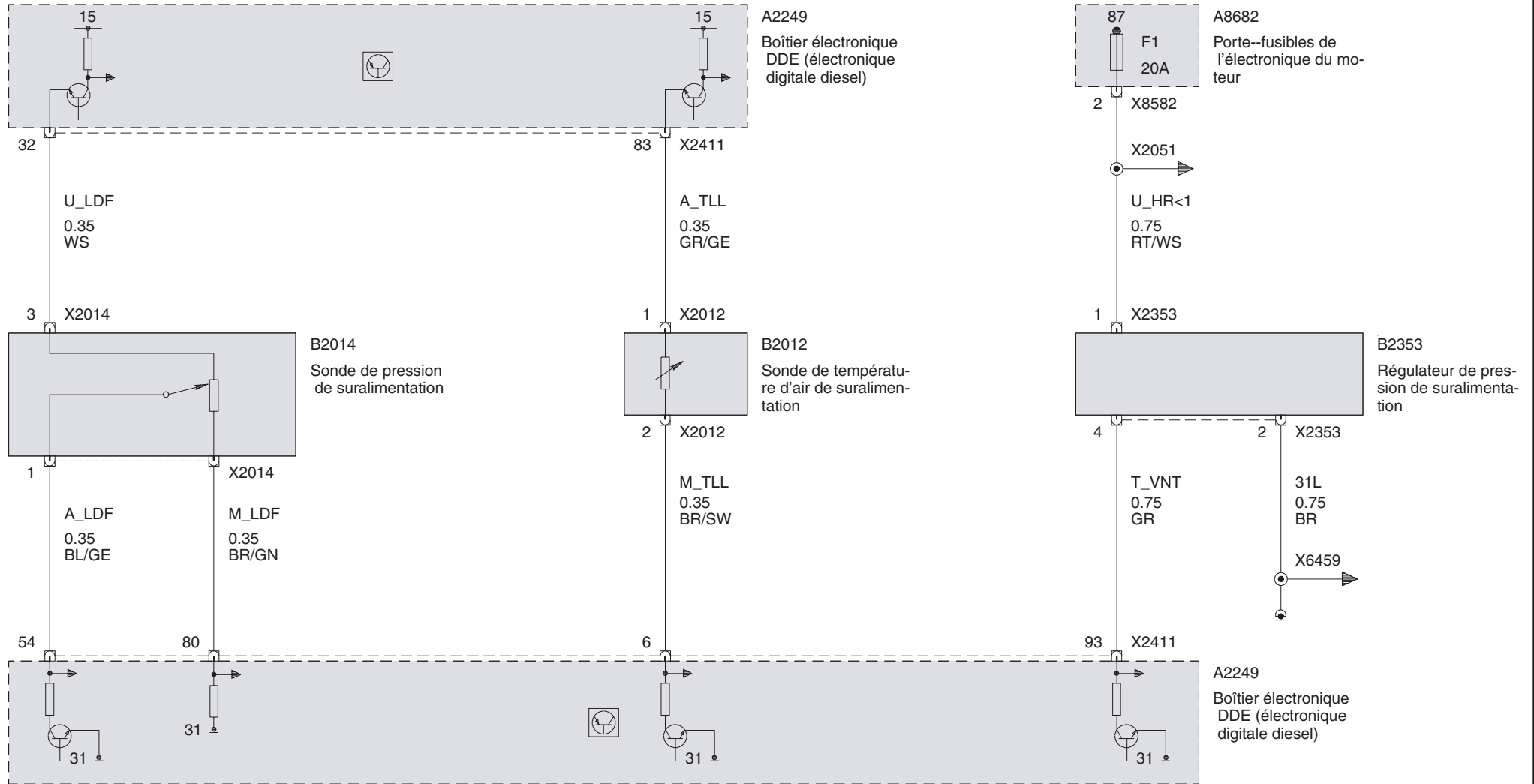

## Régulation du recyclage des gaz d'échappement

Electrovanne de recyclage des gaz d'échappement (Moteur M47/TU)

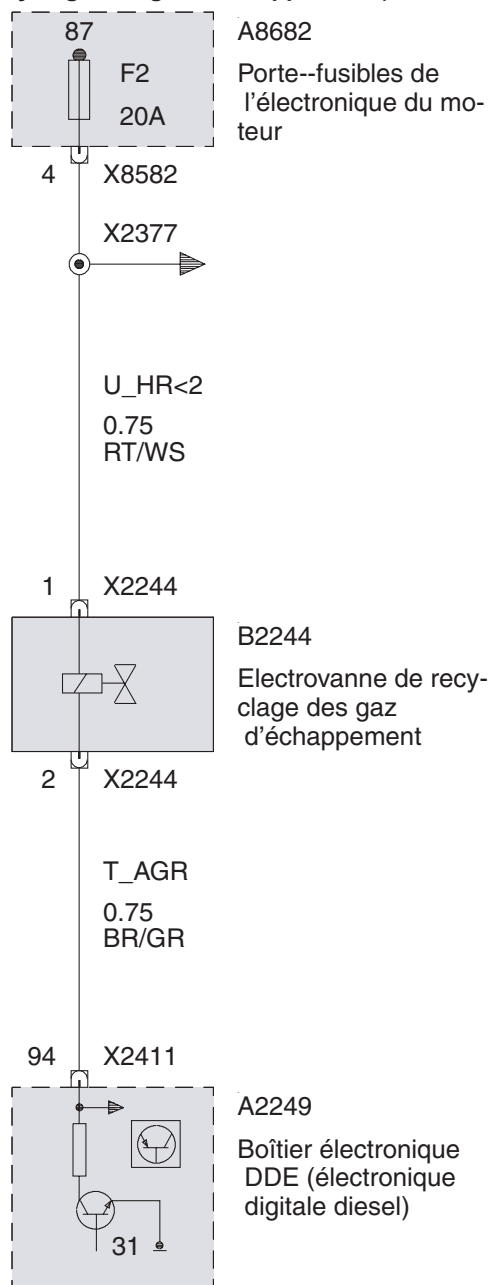

## Electrovanne de recyclage des gaz d'échappement (Moteur M57/TU)

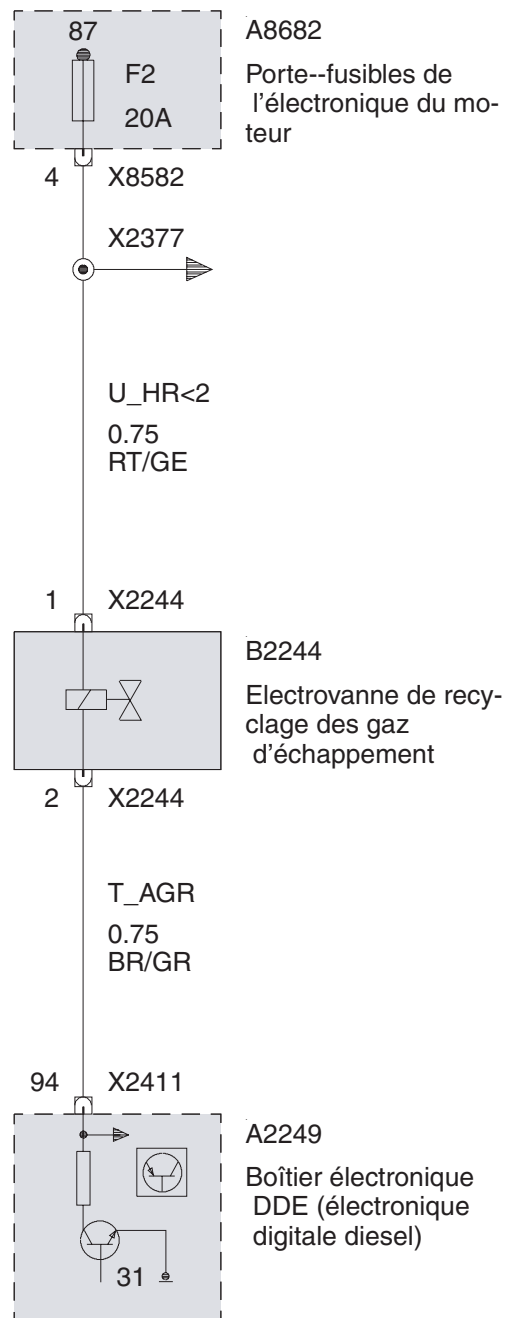

Sonde Lambda (DDE Electronique numérique diesel UE4)

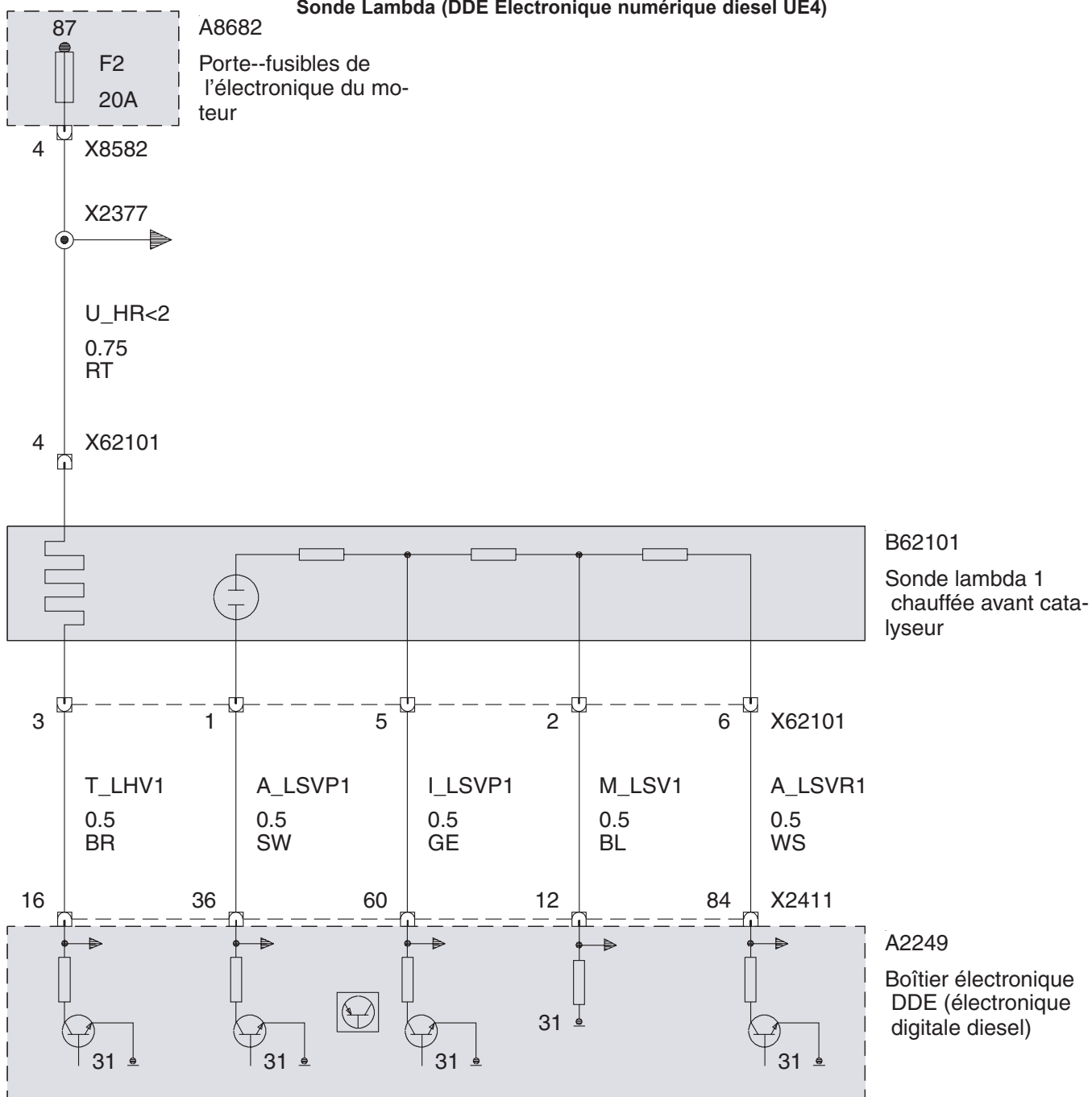

**Alimentation en carburant**  
**Pompe à carburant (Moteur M47/TU)**

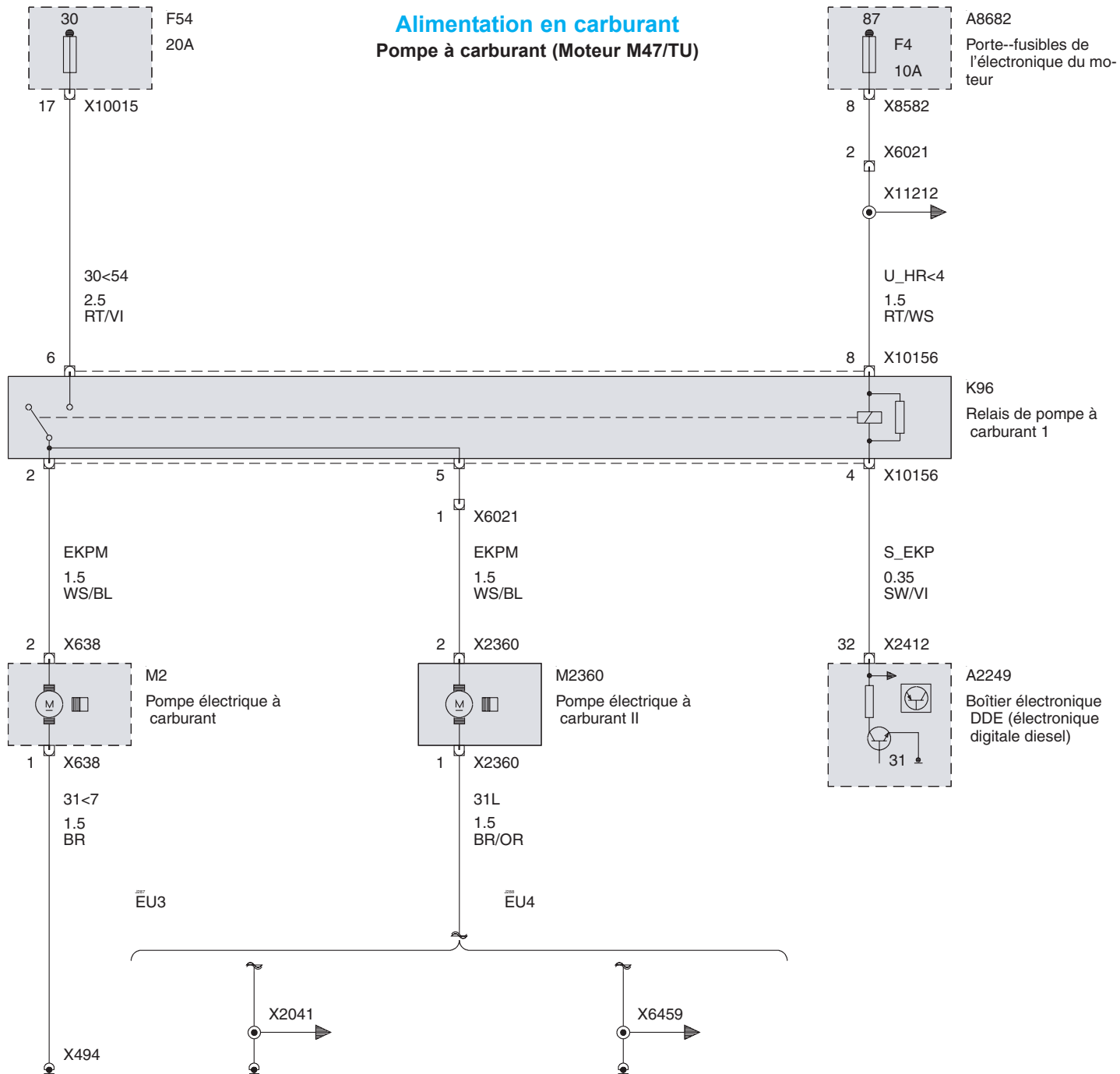

Pompe à carburant (Moteur M57/TU)

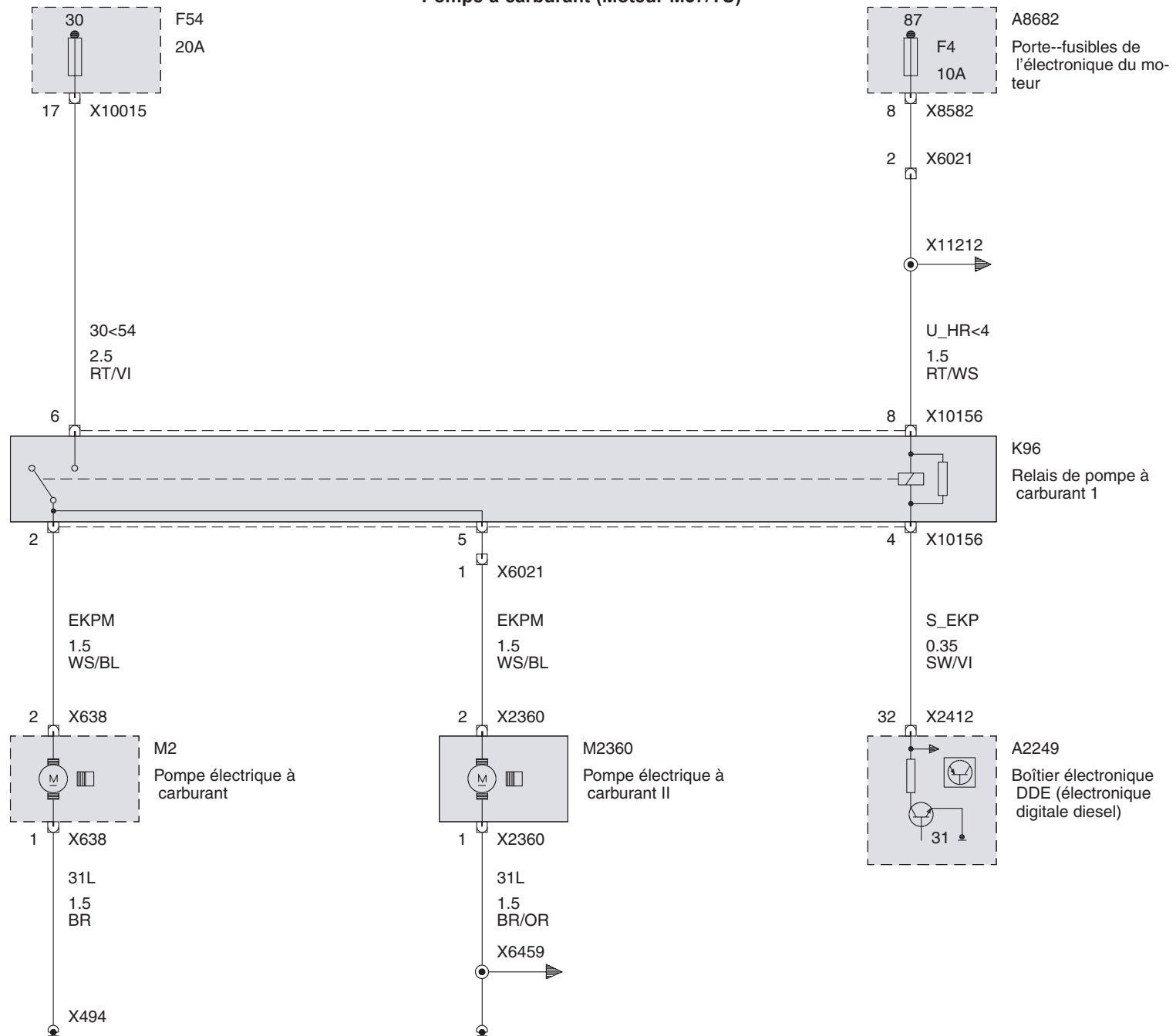



## Sonde de température carburant (Moteur M57/TU ou DDE Electronique numérique diesel UE4)

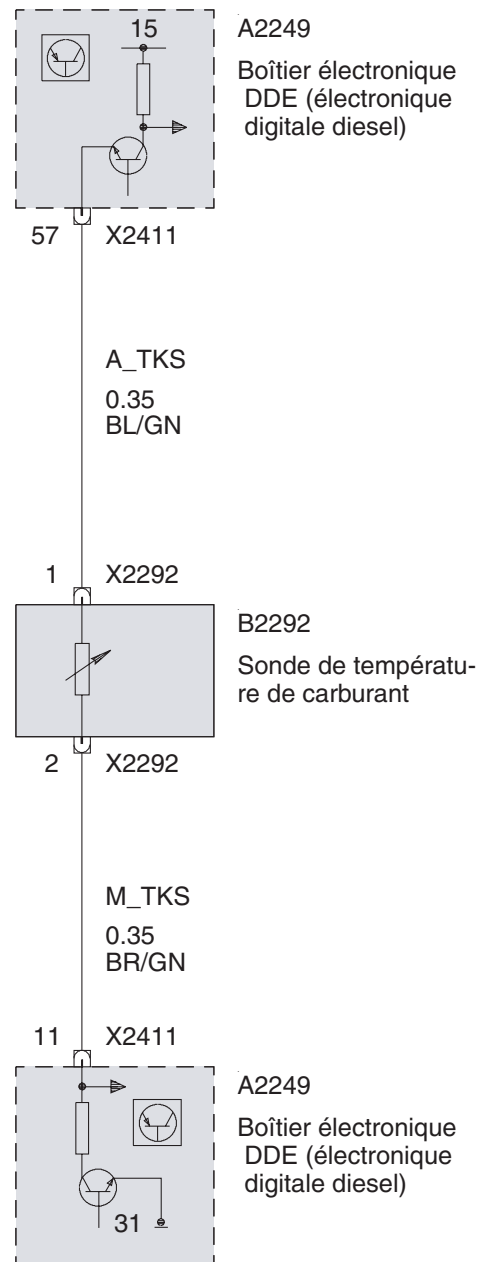



Régulation du carburant (Moteur M47/TU)

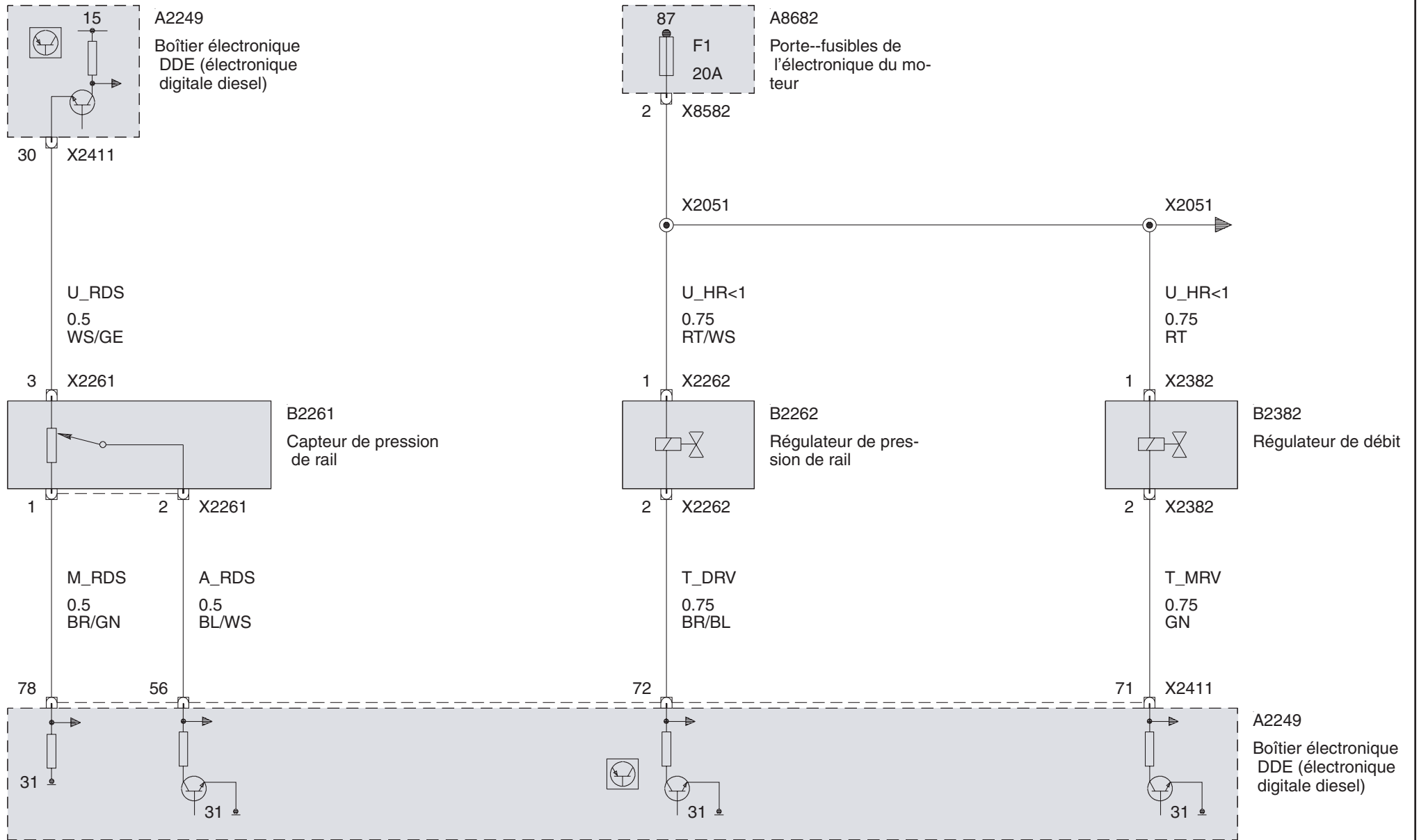

Régulation du carburant (Moteur M57/TU)

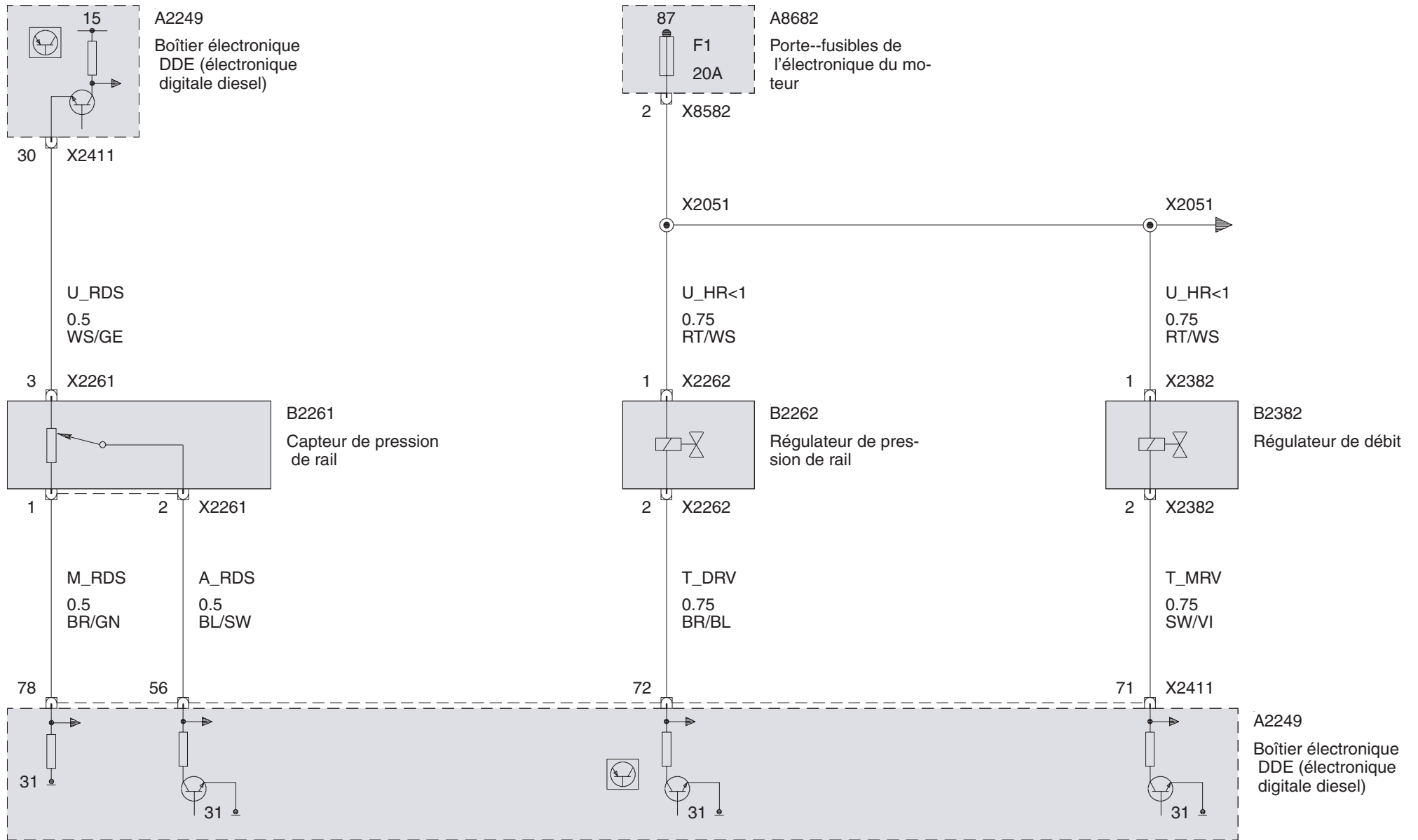

Injecteurs, cylindres 1-4 (Moteur M47/TU)

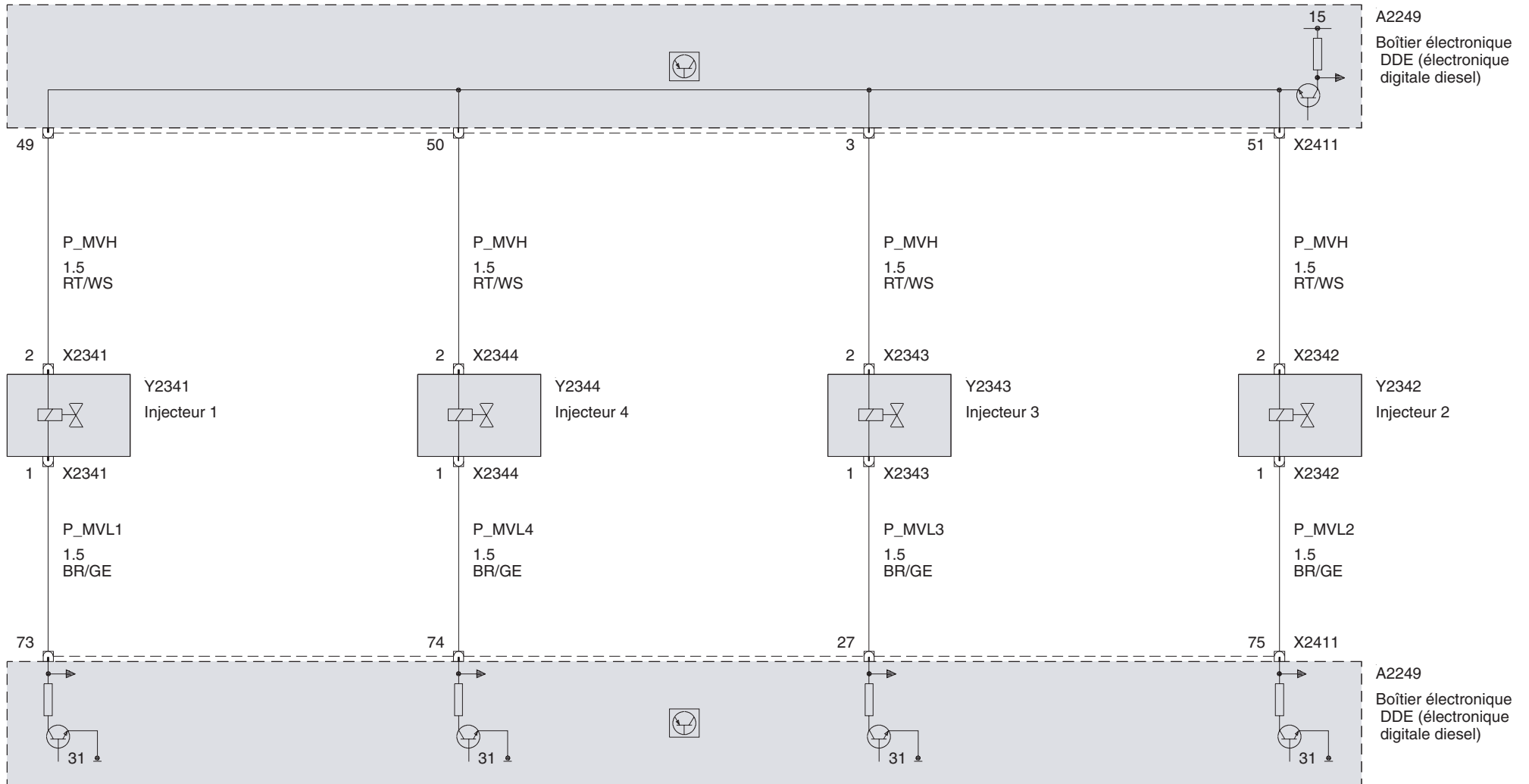

Injecteurs, cylindres 1-6 (Moteur M57/TU)

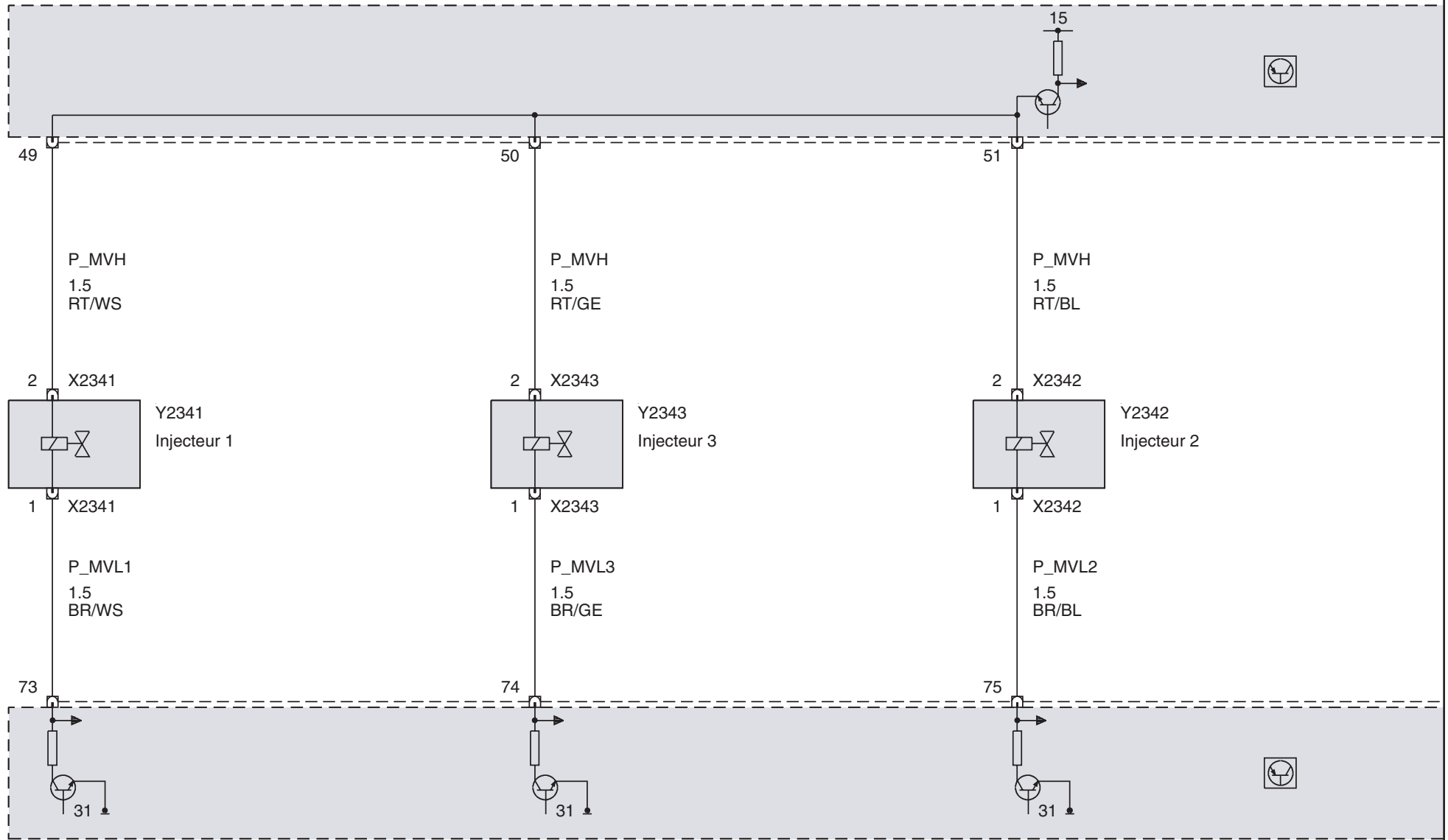

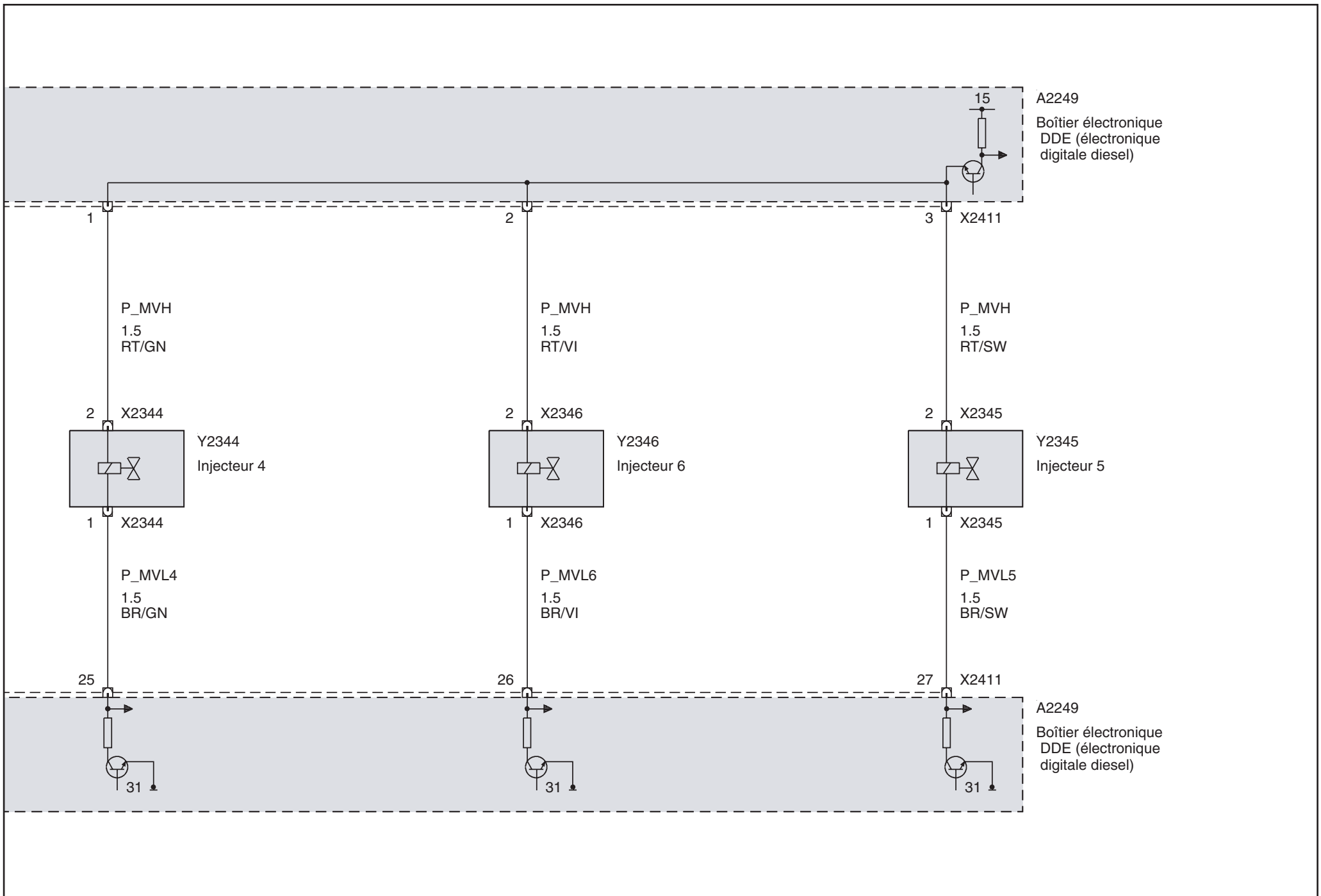

### Alimentation en huile moteur Lampe témoin de la pression d'huile (jusqu'à 2003\_03)

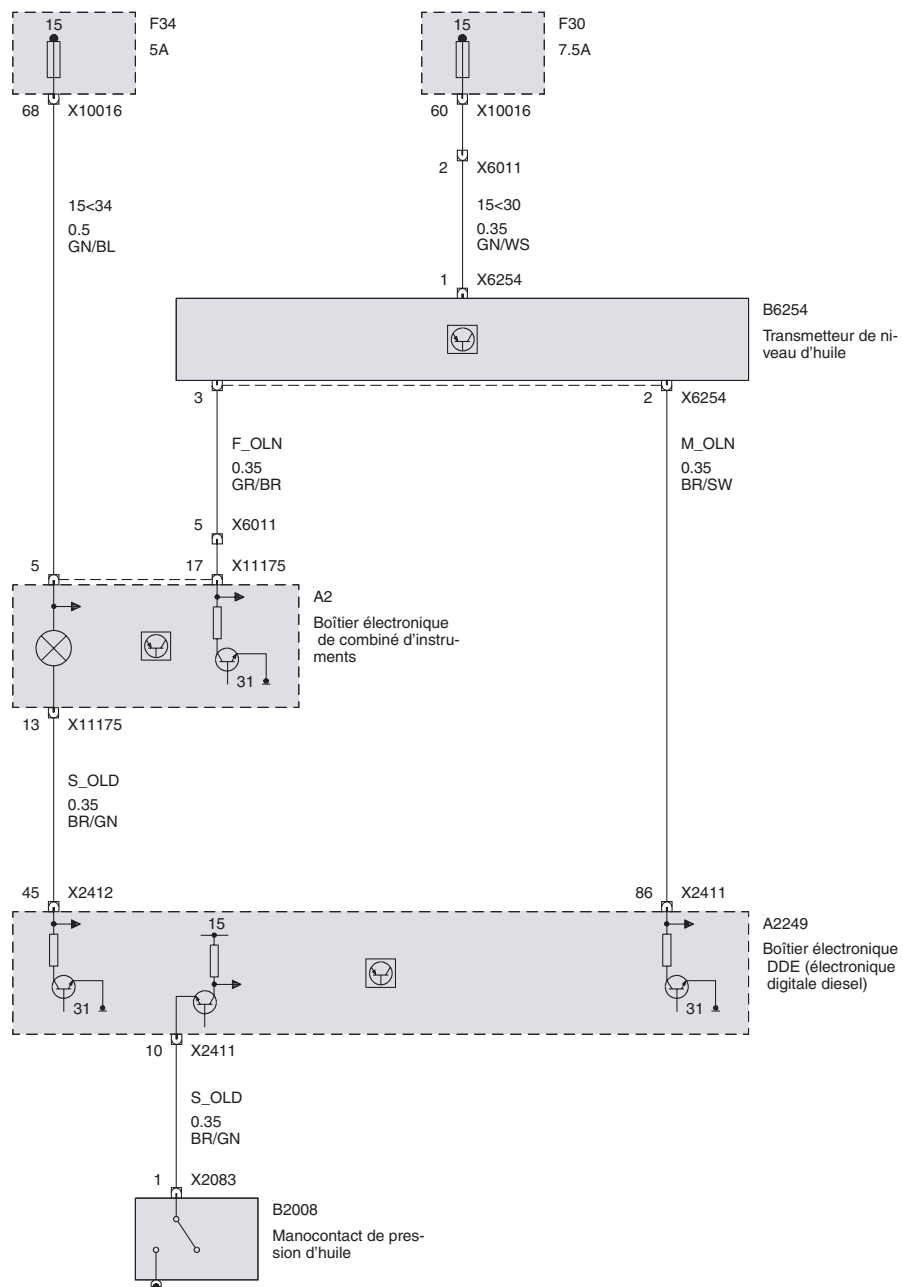



Lampe témoin de la pression d'huile (à partir de 2003\_03)

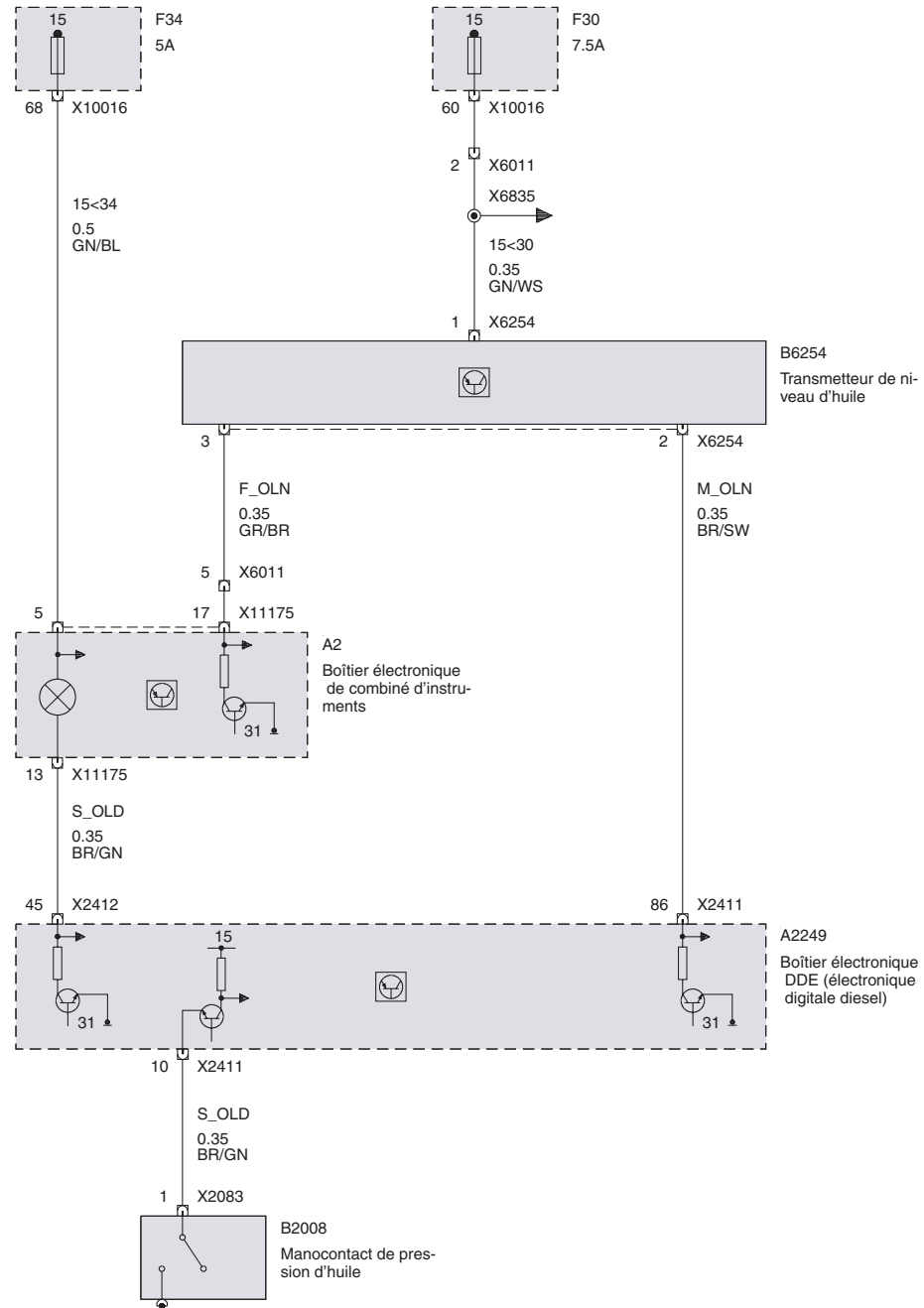

**Système de préchauffage**  
Système de préchauffage (Moteur M47/TU)

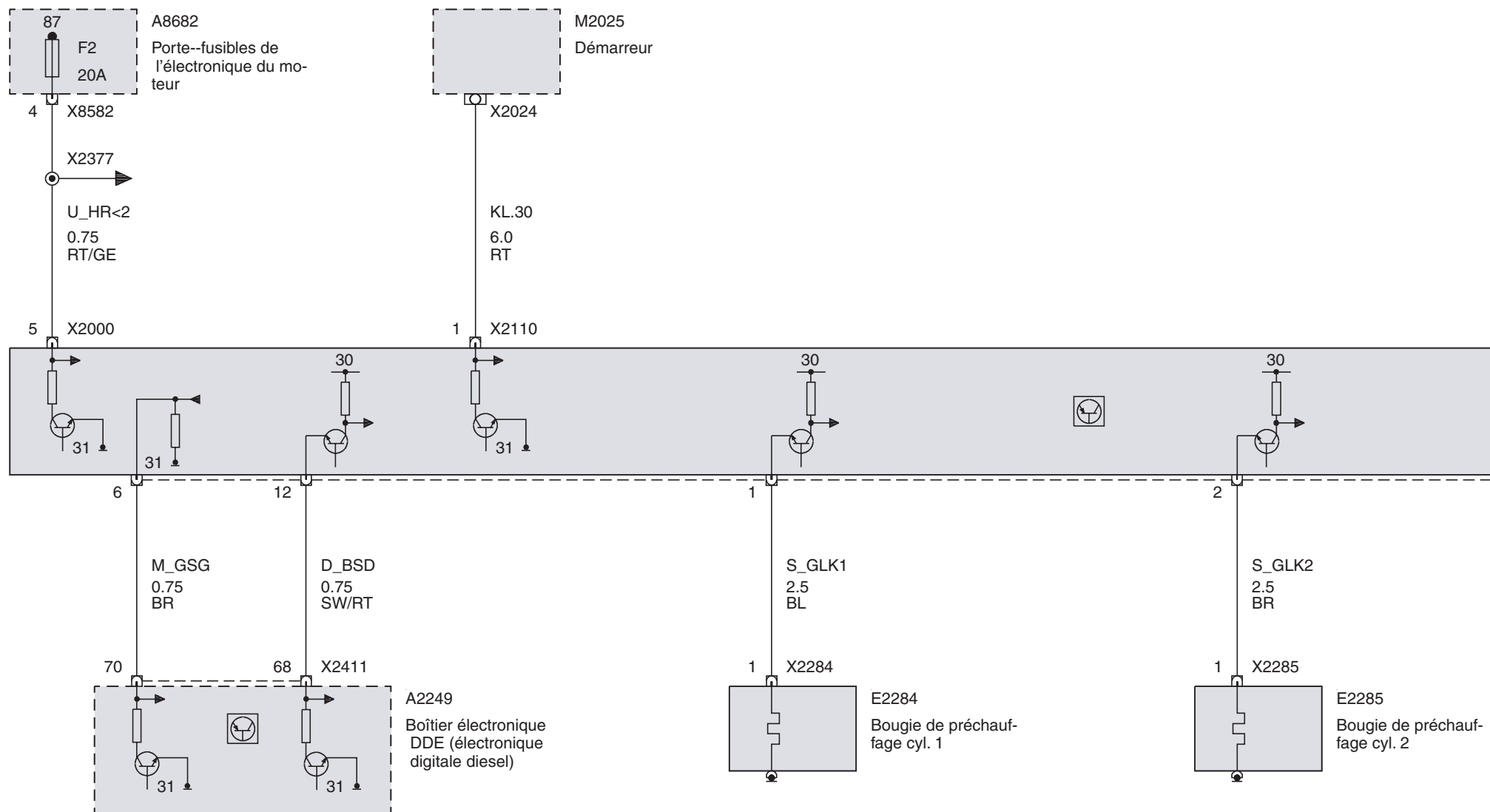

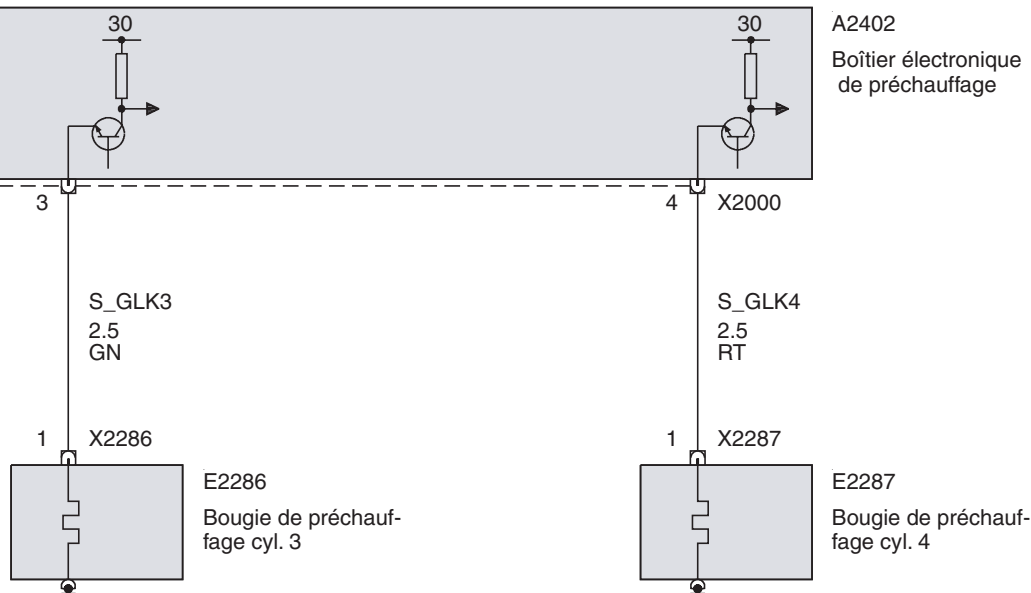

Système de préchauffage (Moteur M57/TU)

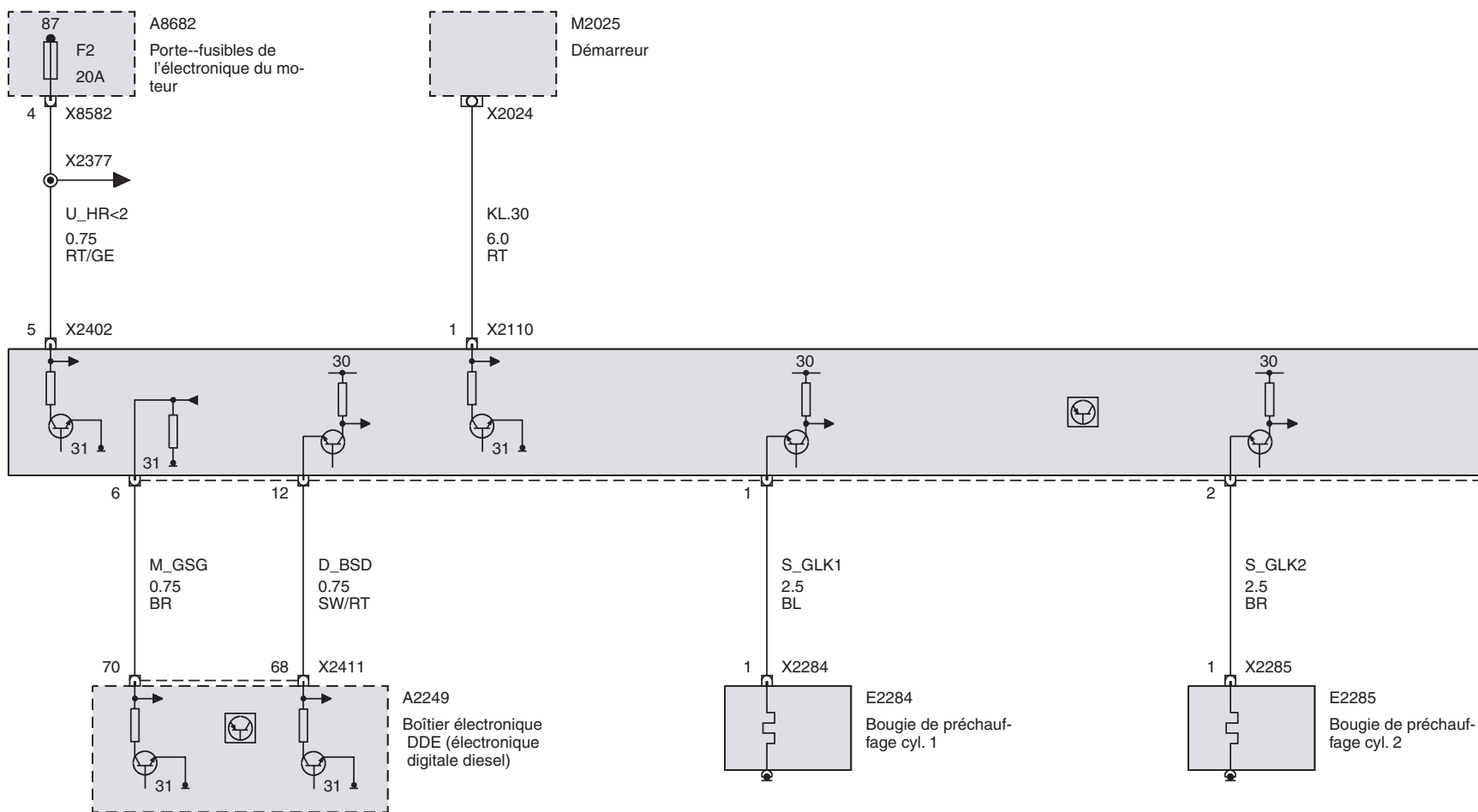

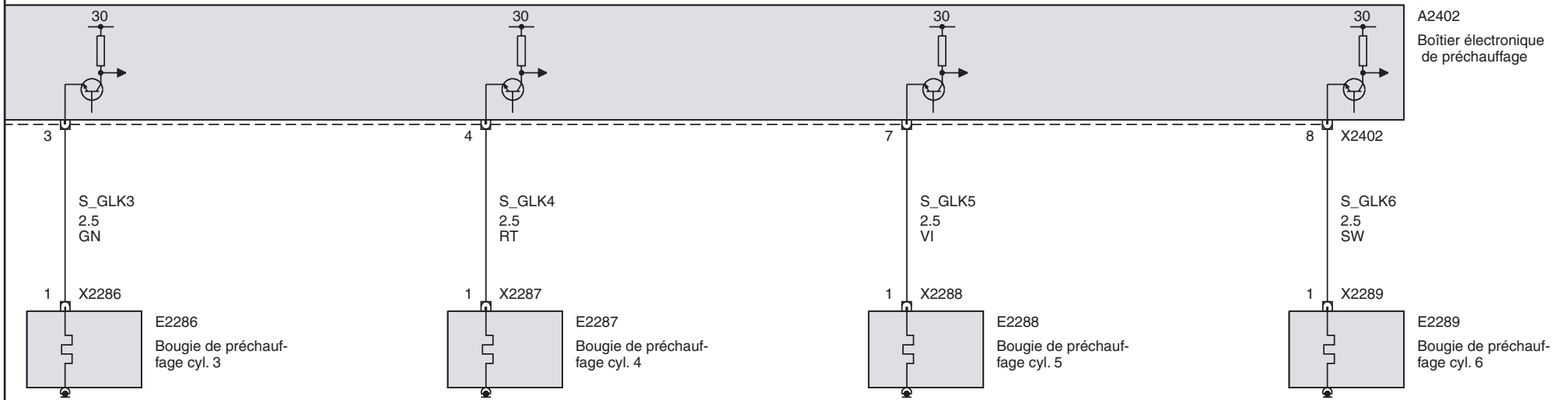

Signal de vitesse

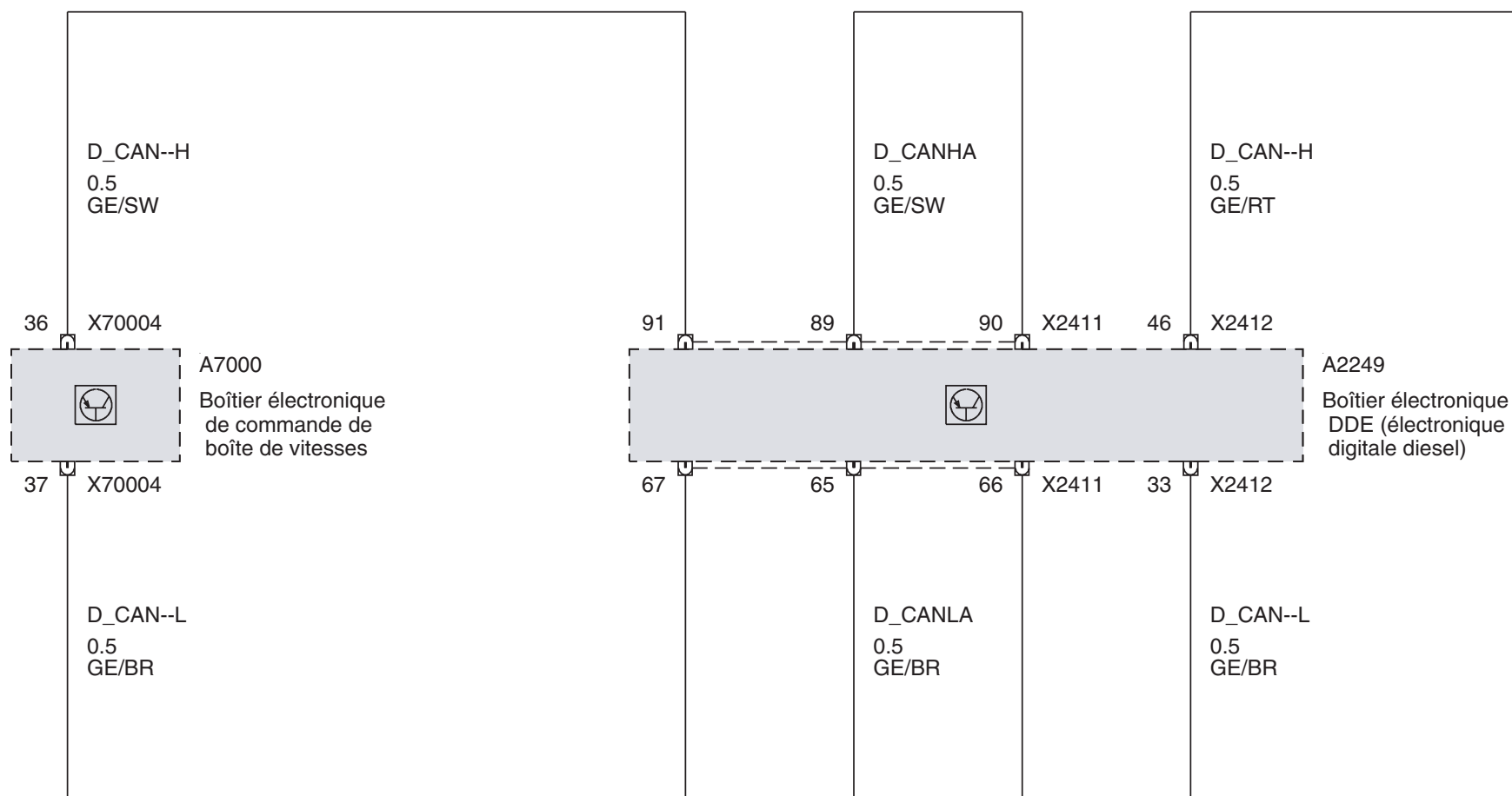

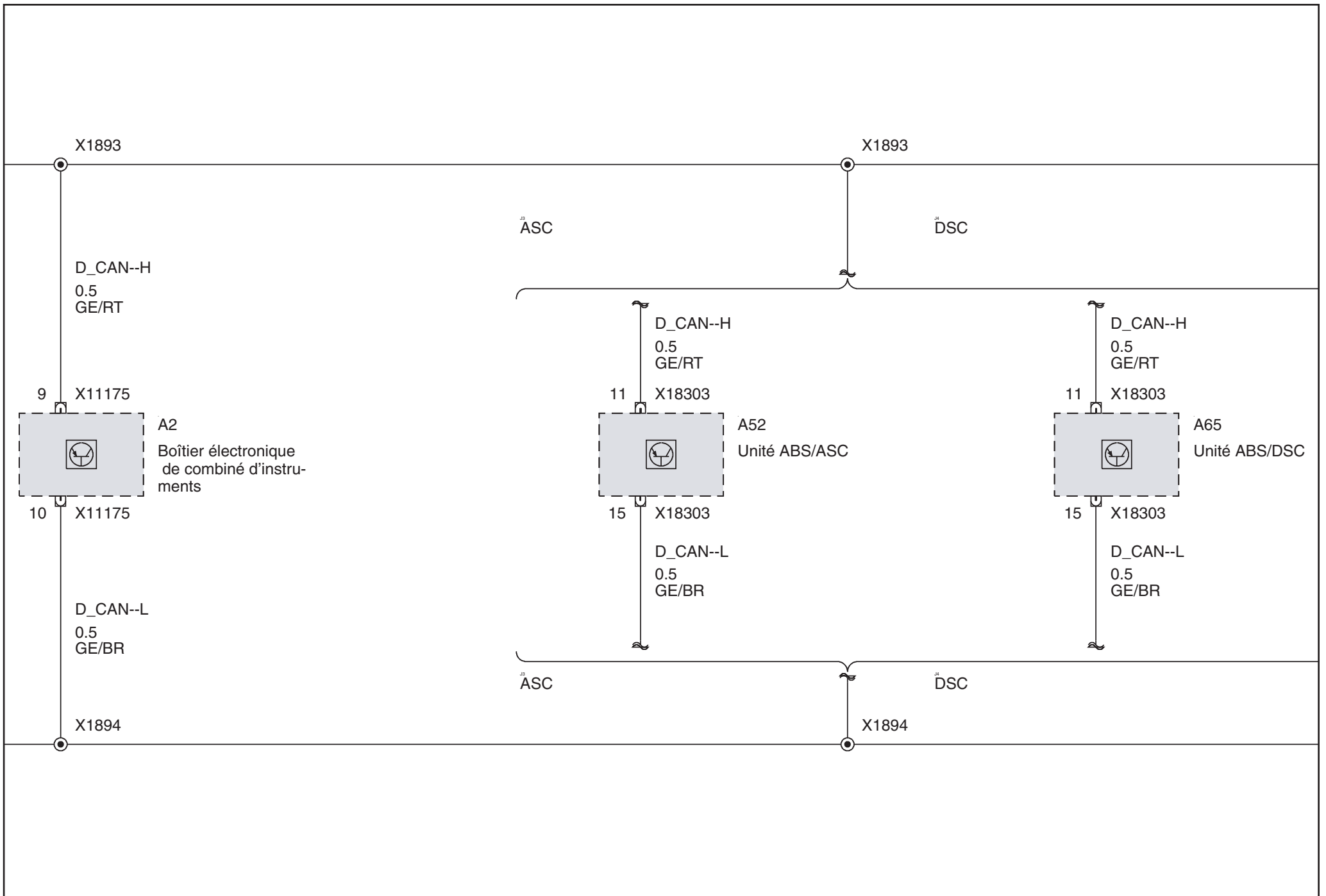

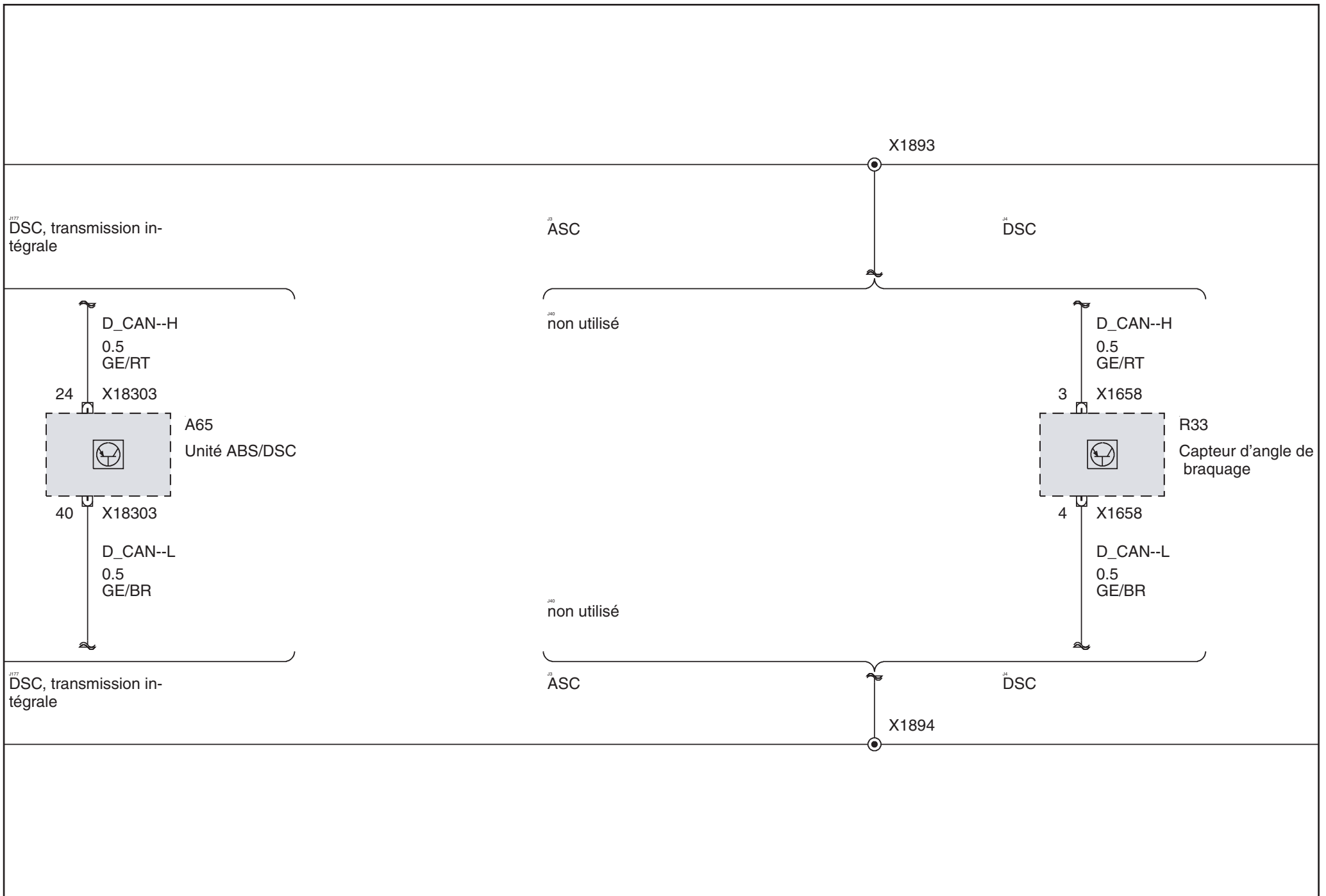



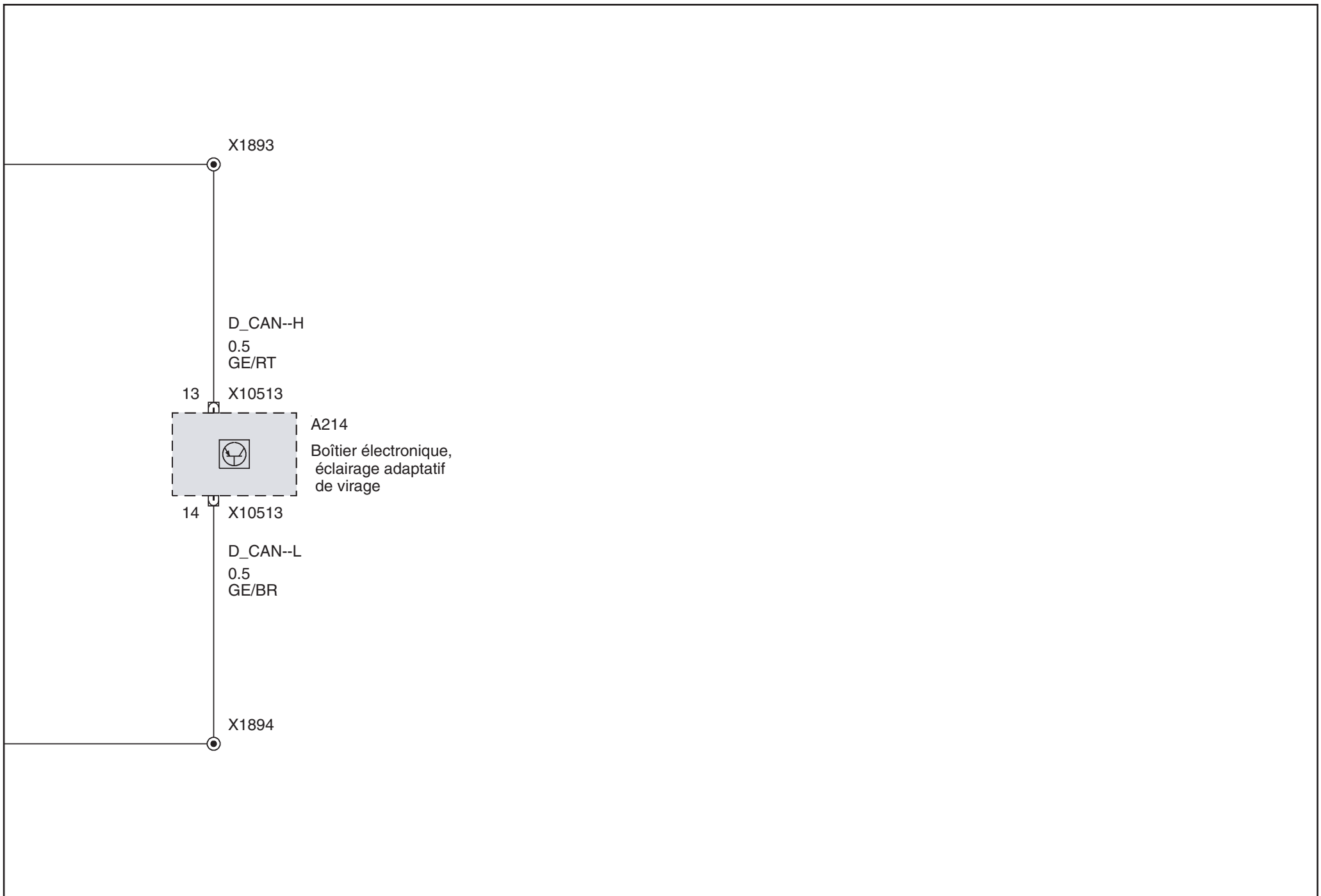

Silentblocs moteur (Moteur M57/TU)

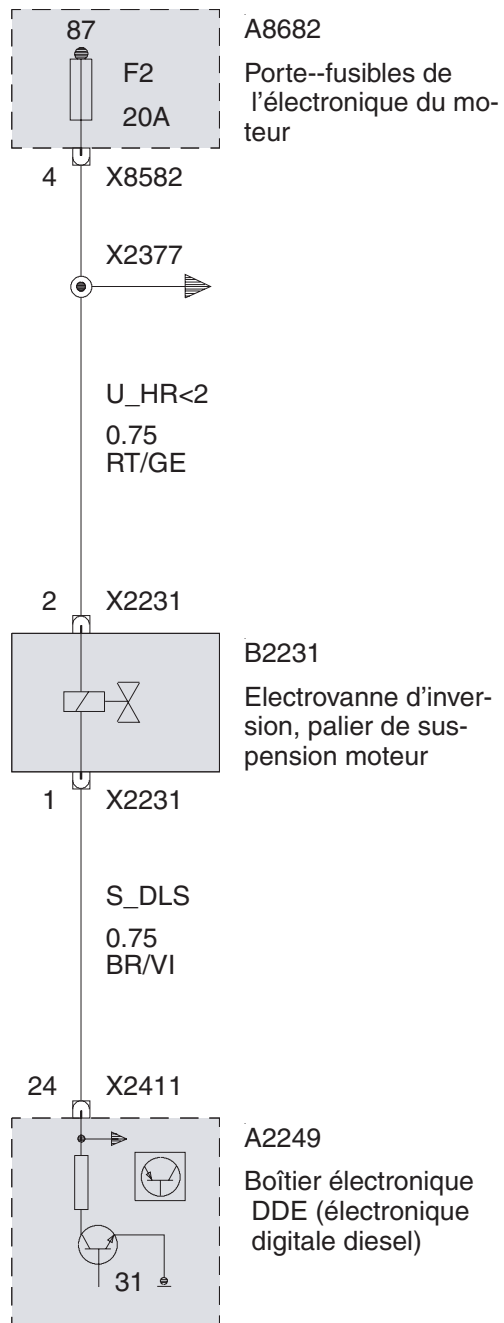

## Blocage antidémarrage électronique (EWS)

Commande du démarreur Signaux d'interfaces (jusque 2002\_03)

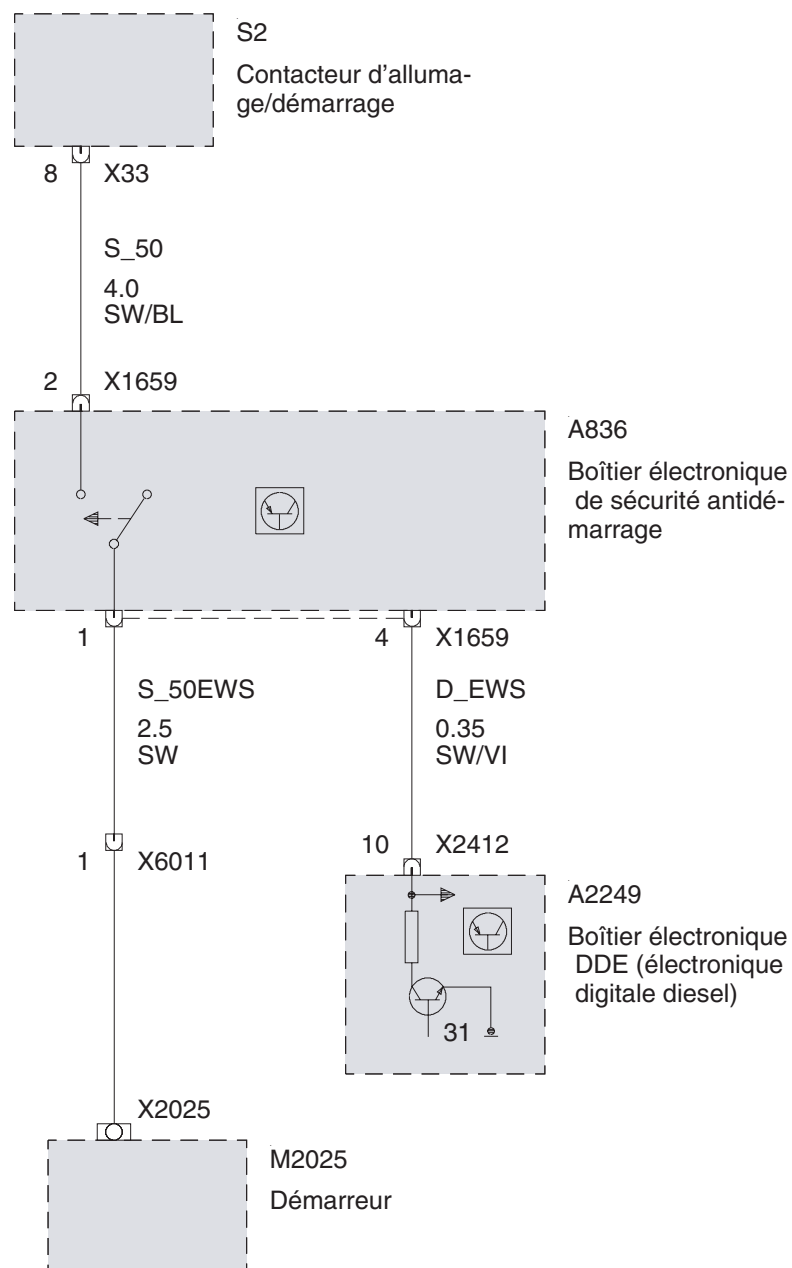

Commande du démarreur Signaux d'interfaces (à partir de 2002\_03)

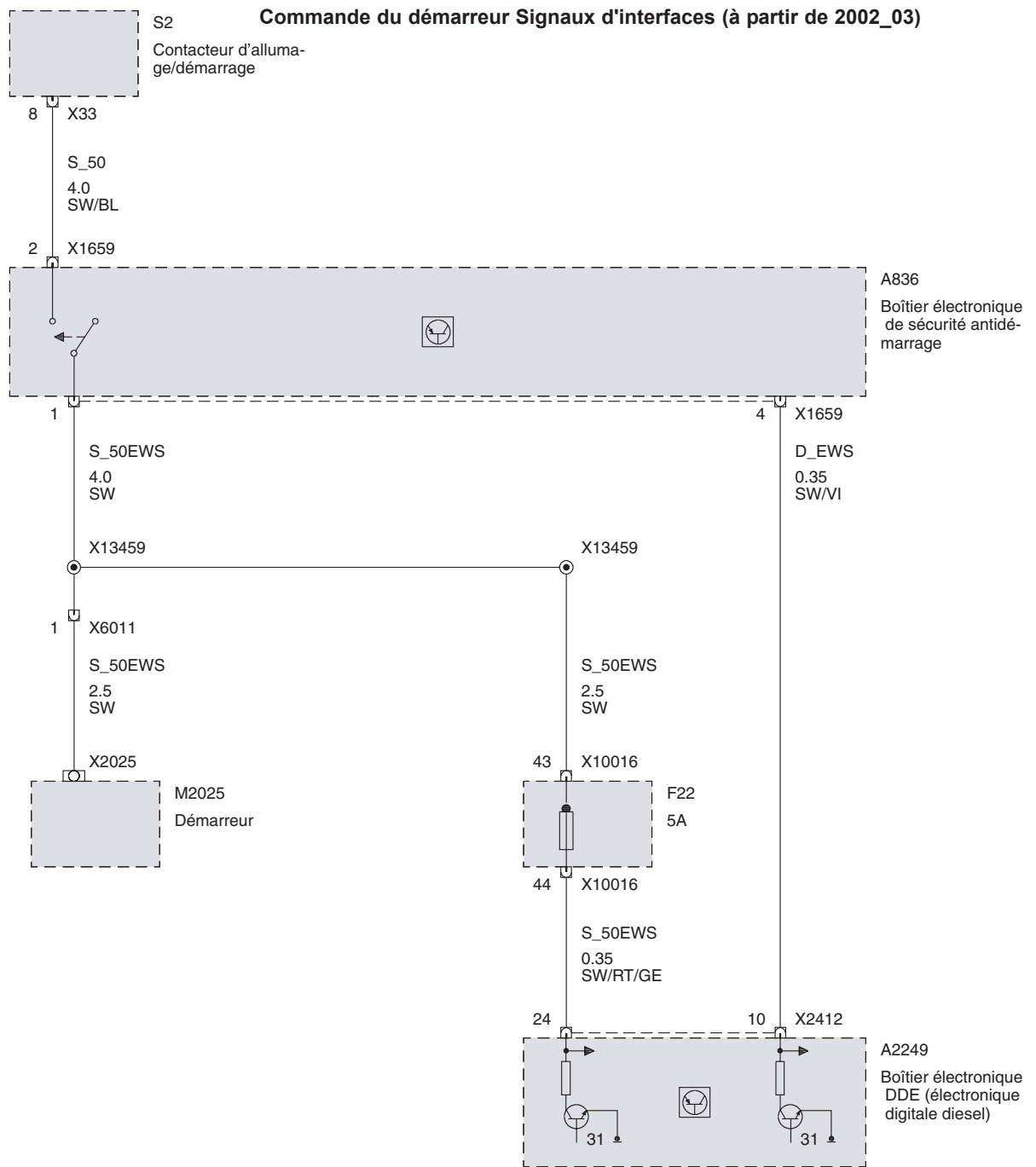

## Chauffage dégazage du carter moteur (Moteur M57/TU avec DDE Electronique numérique diesel UE4)

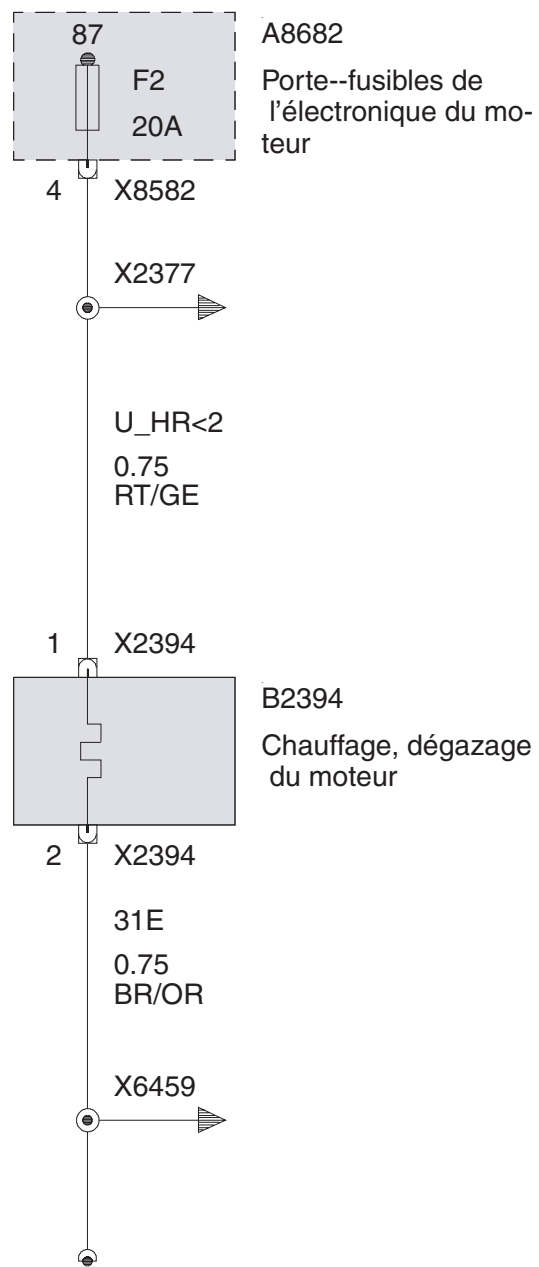

Alimentation en tension avec relais principal

Alimentation A2249, boîtier électronique DDE (Moteur M47/TU sauf Coupé)

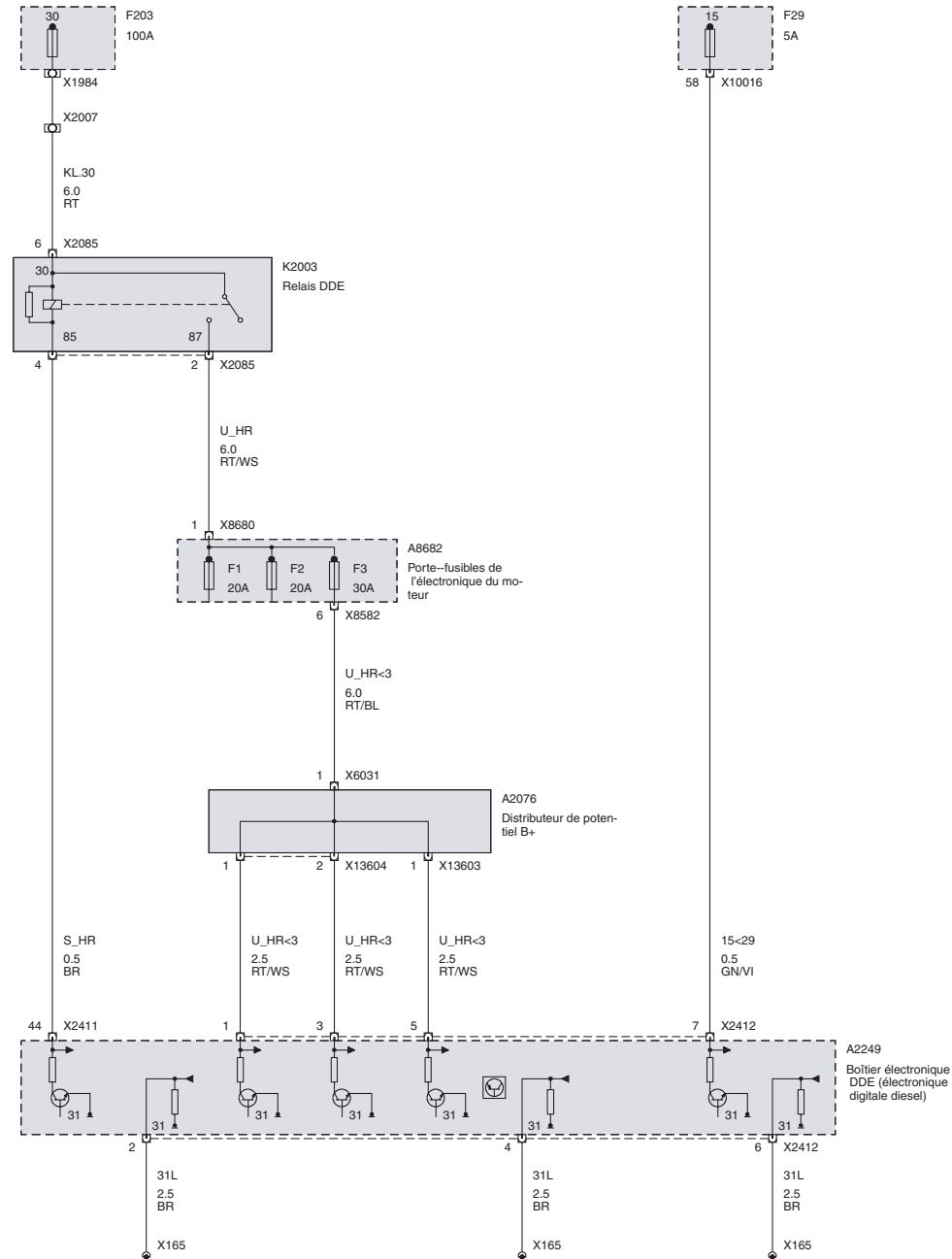

Alimentation A2249, boîtier électronique DDE (Moteur M57/TU sauf Coupé)

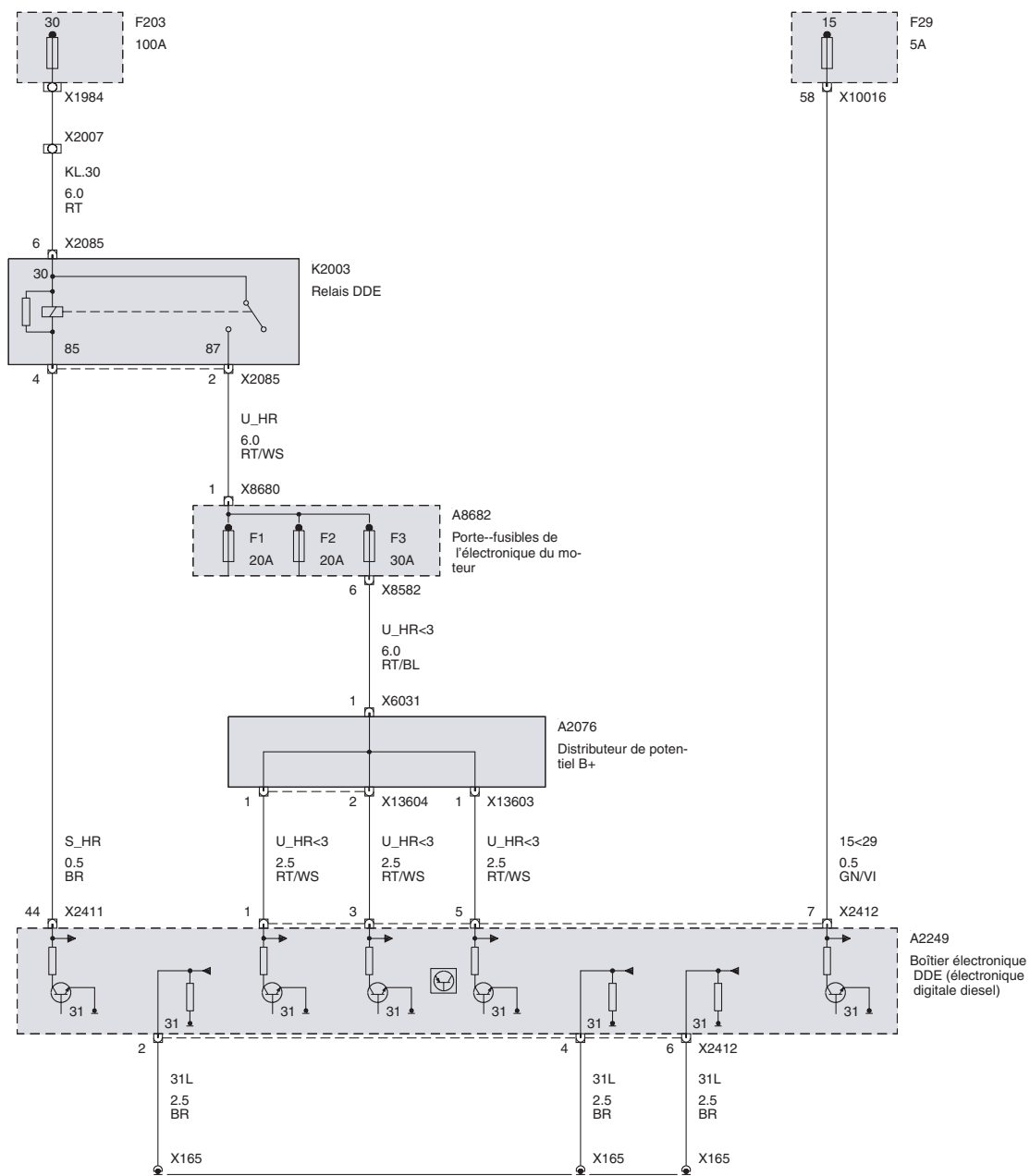

Alimentation A2249, boîtier électronique DDE (Moteur M57/TU avec Coupé)

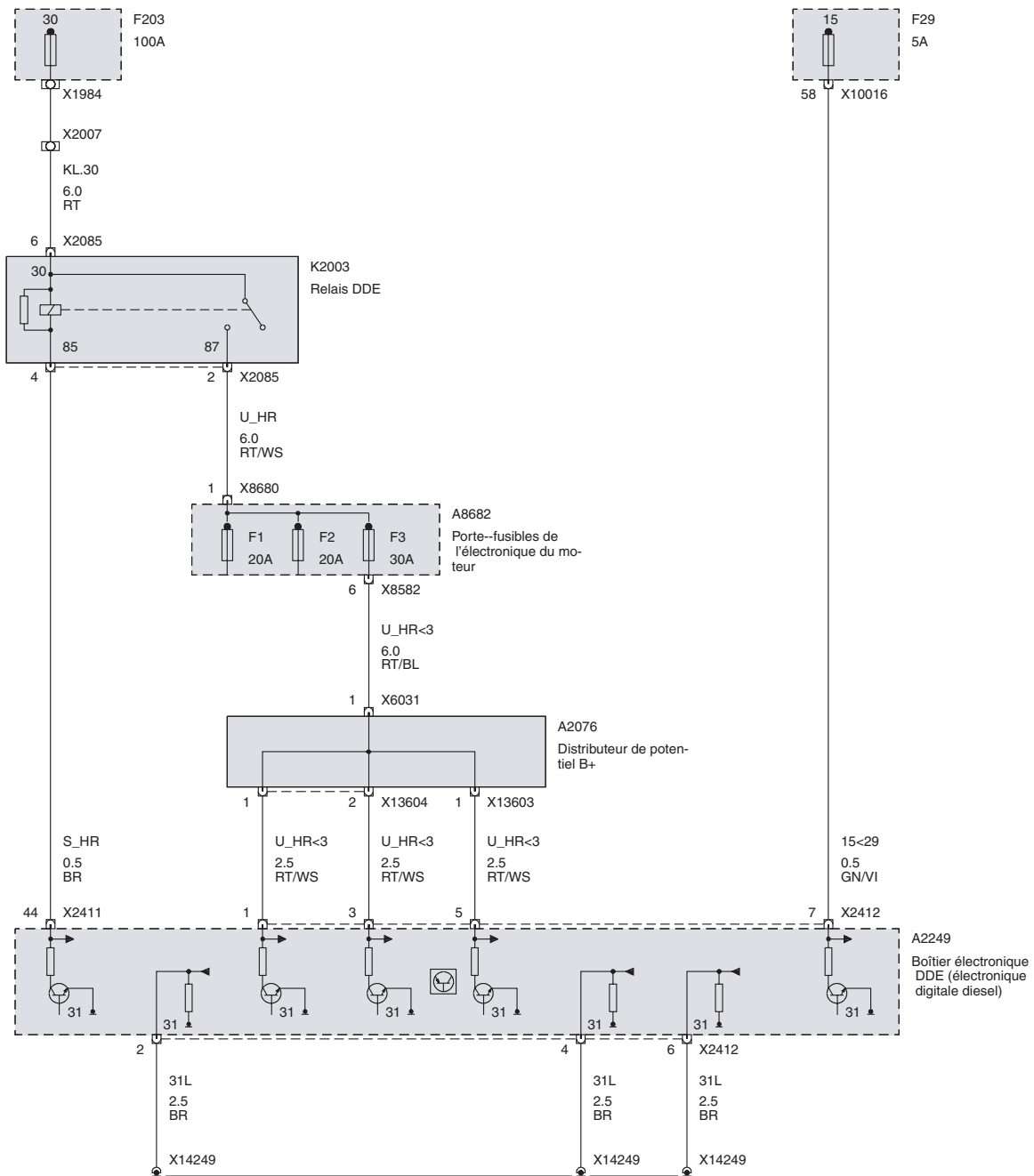



Alimentation A2249, boîtier électronique DDE (Moteur M47/TU avec Coupé)

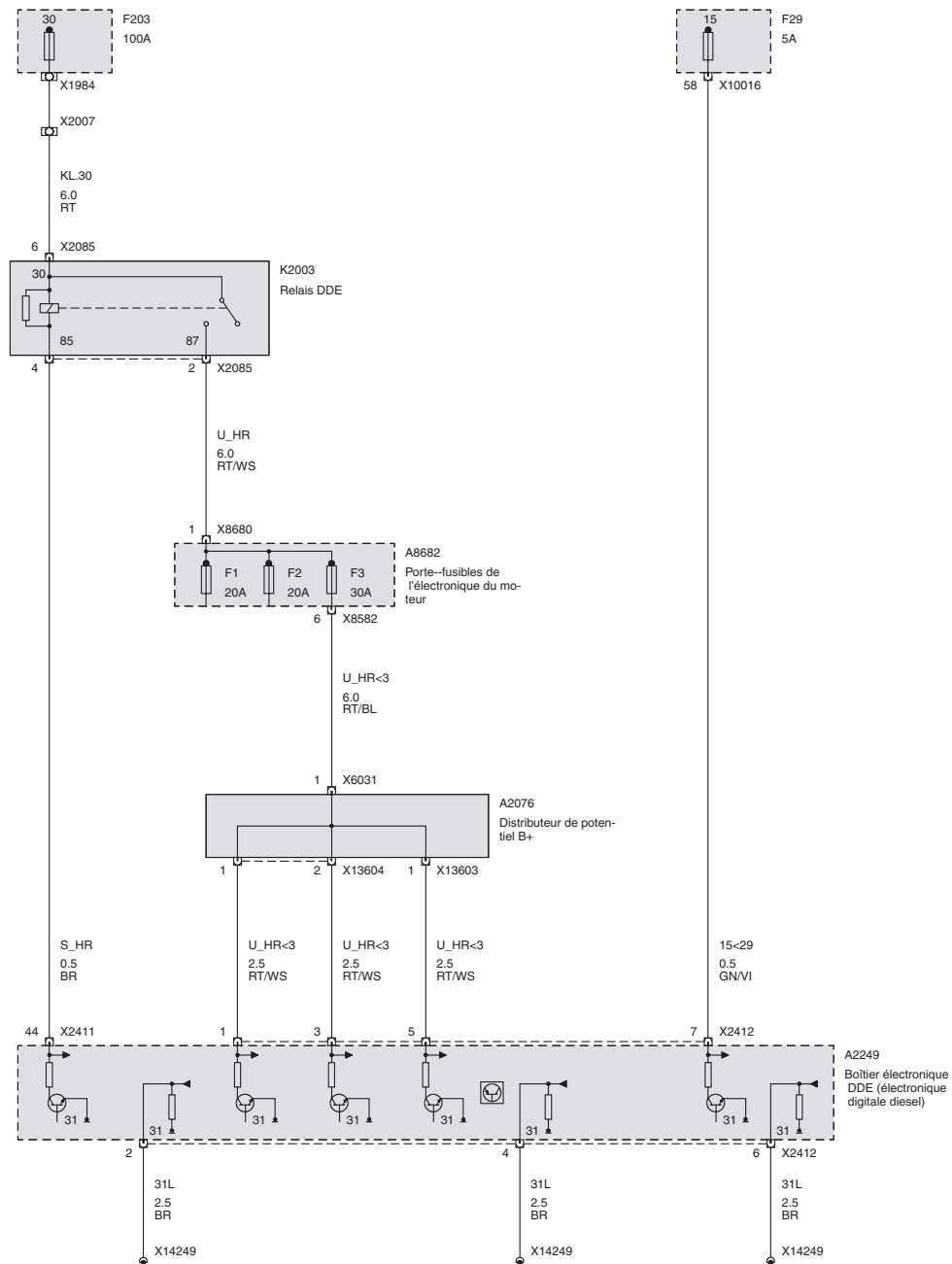

## Commande de boîte de vitesses GS8.60 (DME Electronique moteur MS43)

### Commande de boîte de vitesses

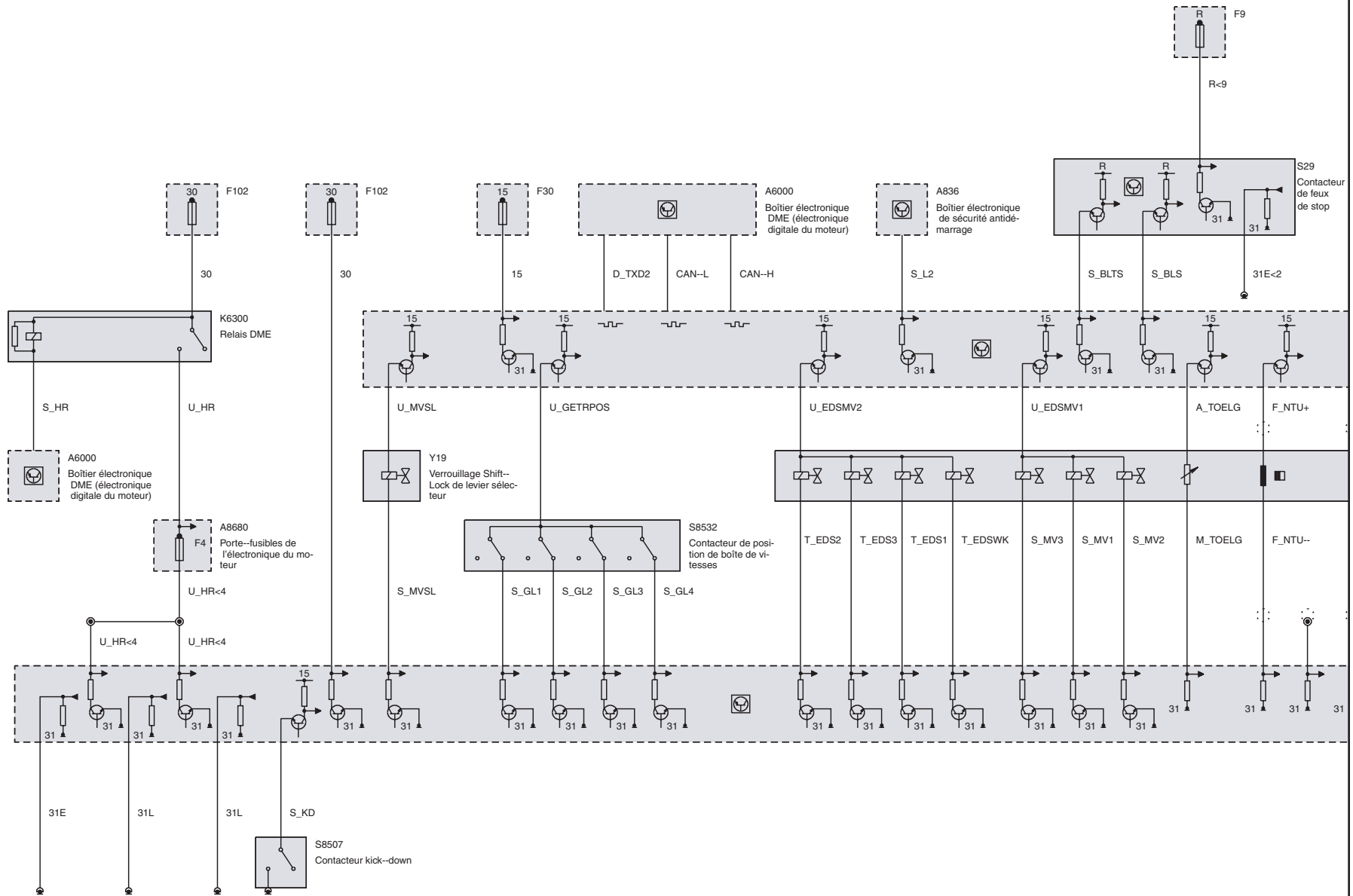

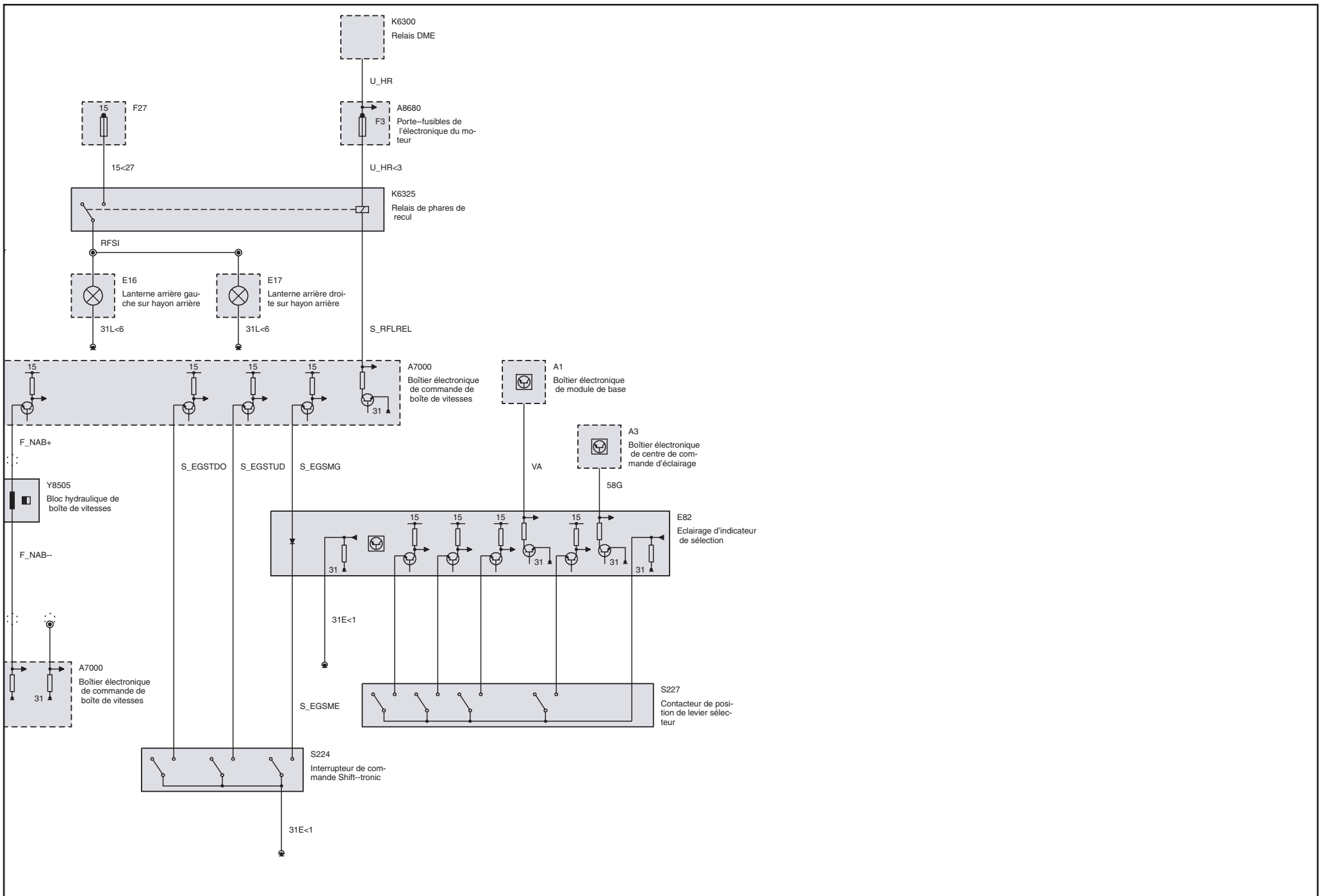

Alimentation en tension

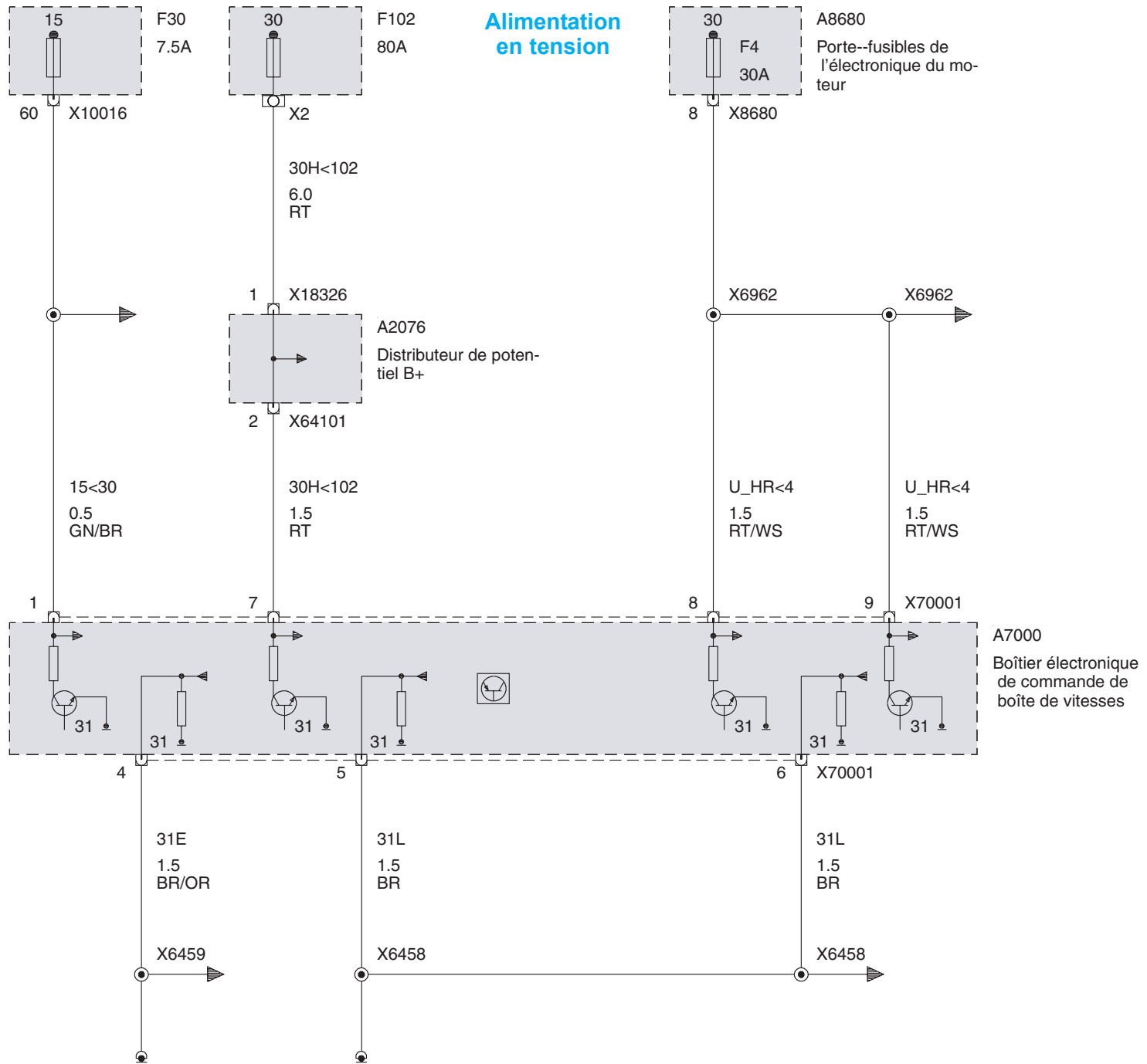

## Verrouillage Shift-Lock de levier sélecteur

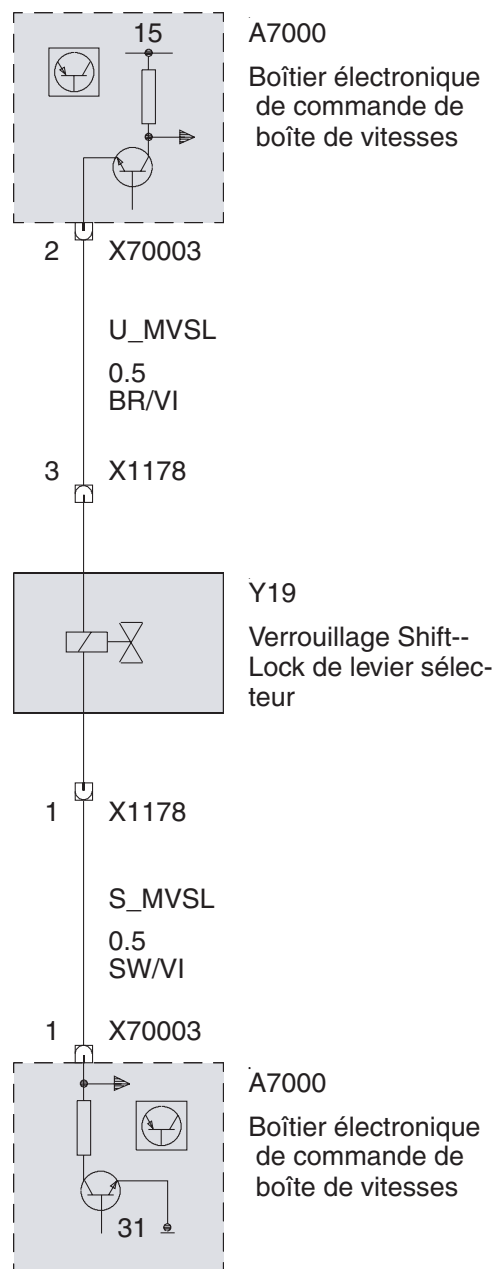

Levier sélecteur

Contacteur de position BV

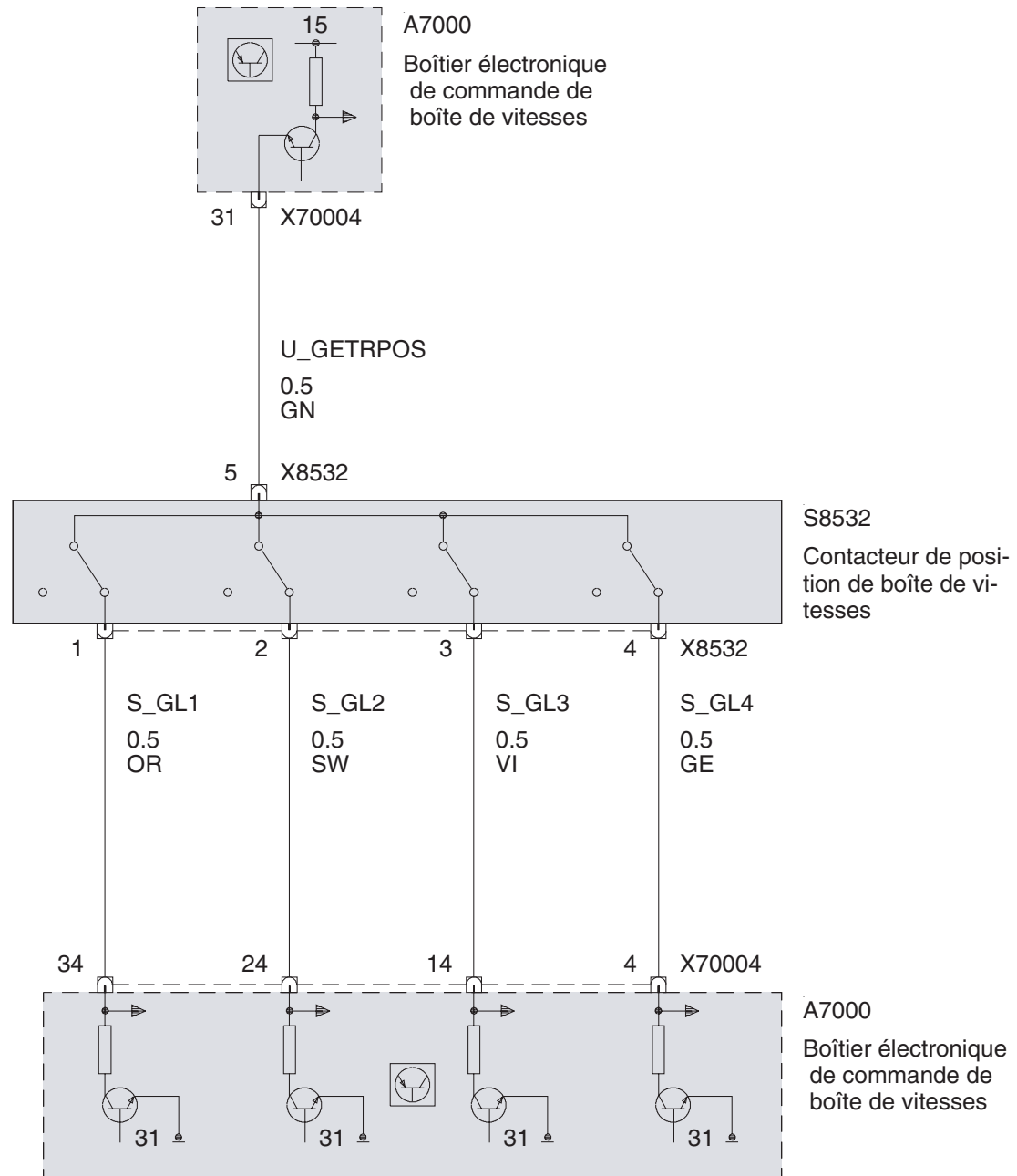

Contacteur commande pas-à-pas

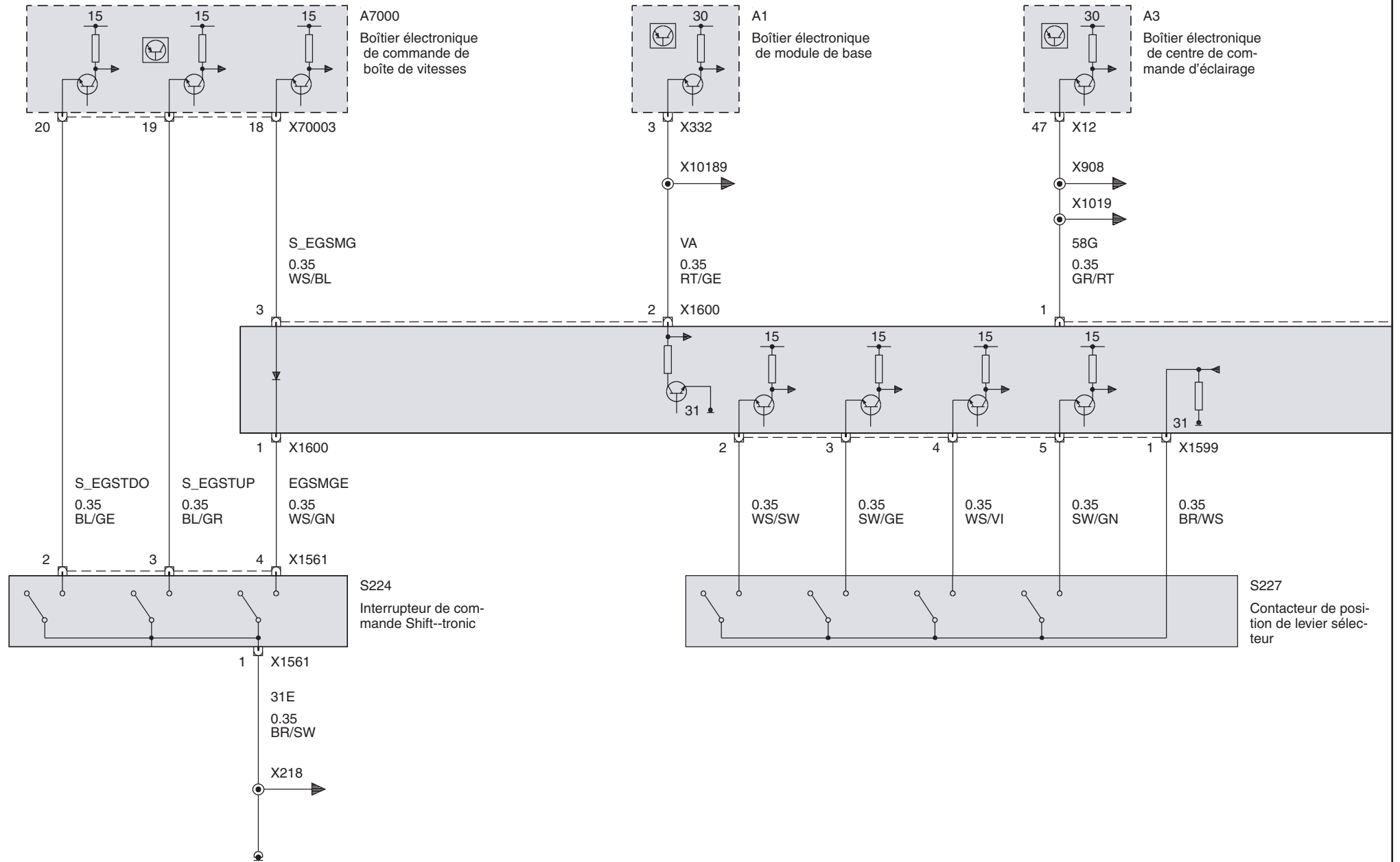

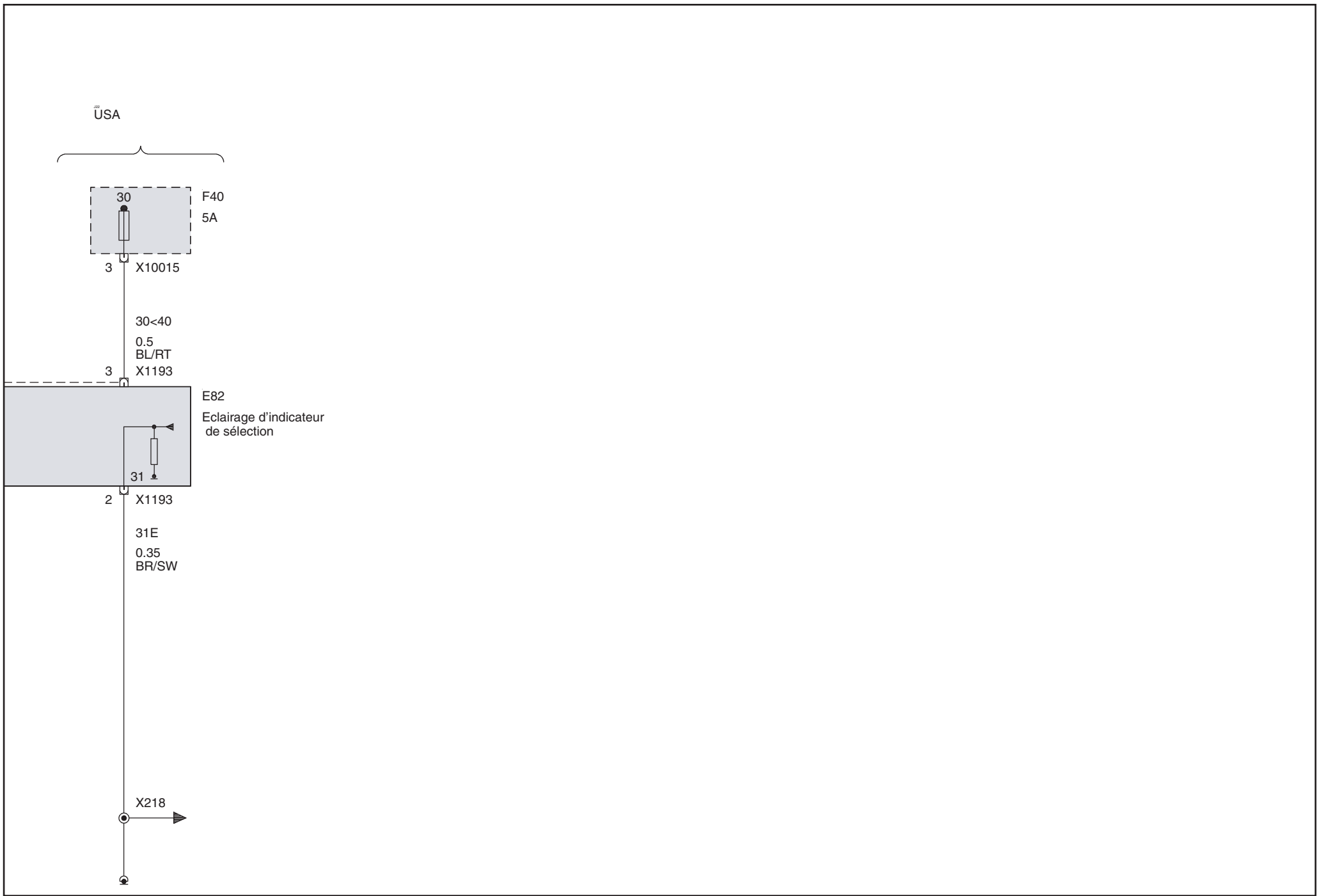



Contacteur de position BV

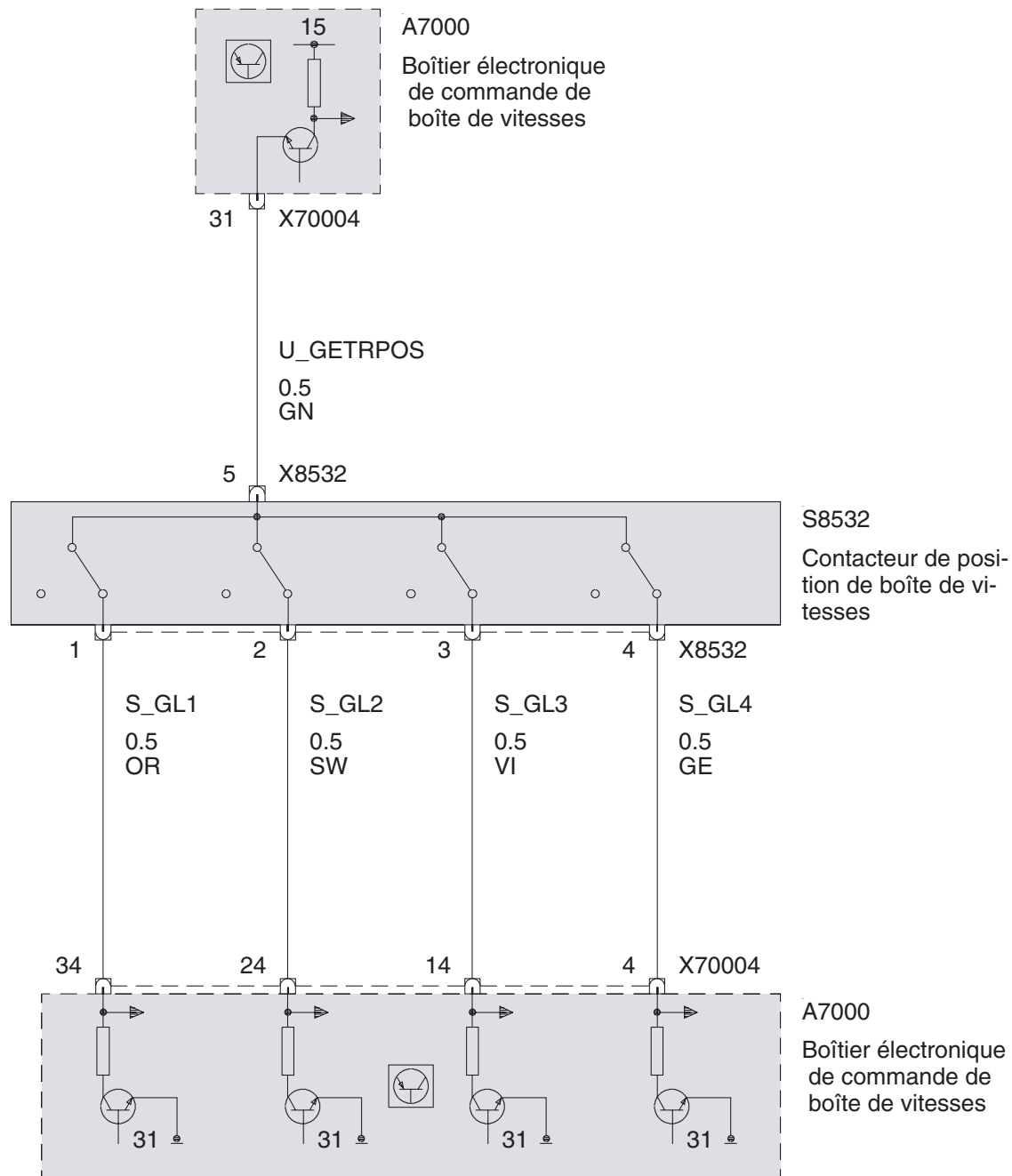

Phare de recul

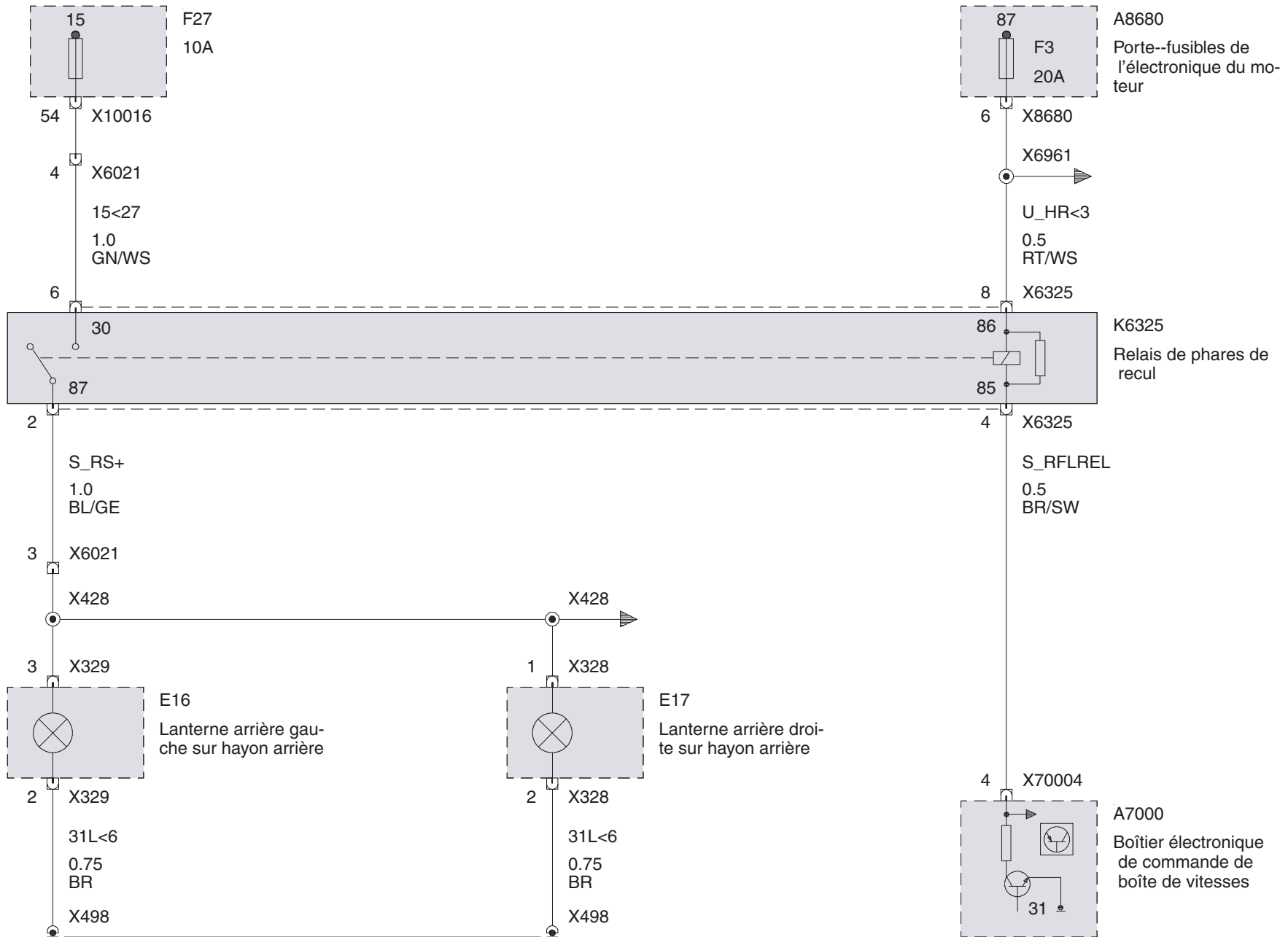

Bloc de commande de boîte de vitesses

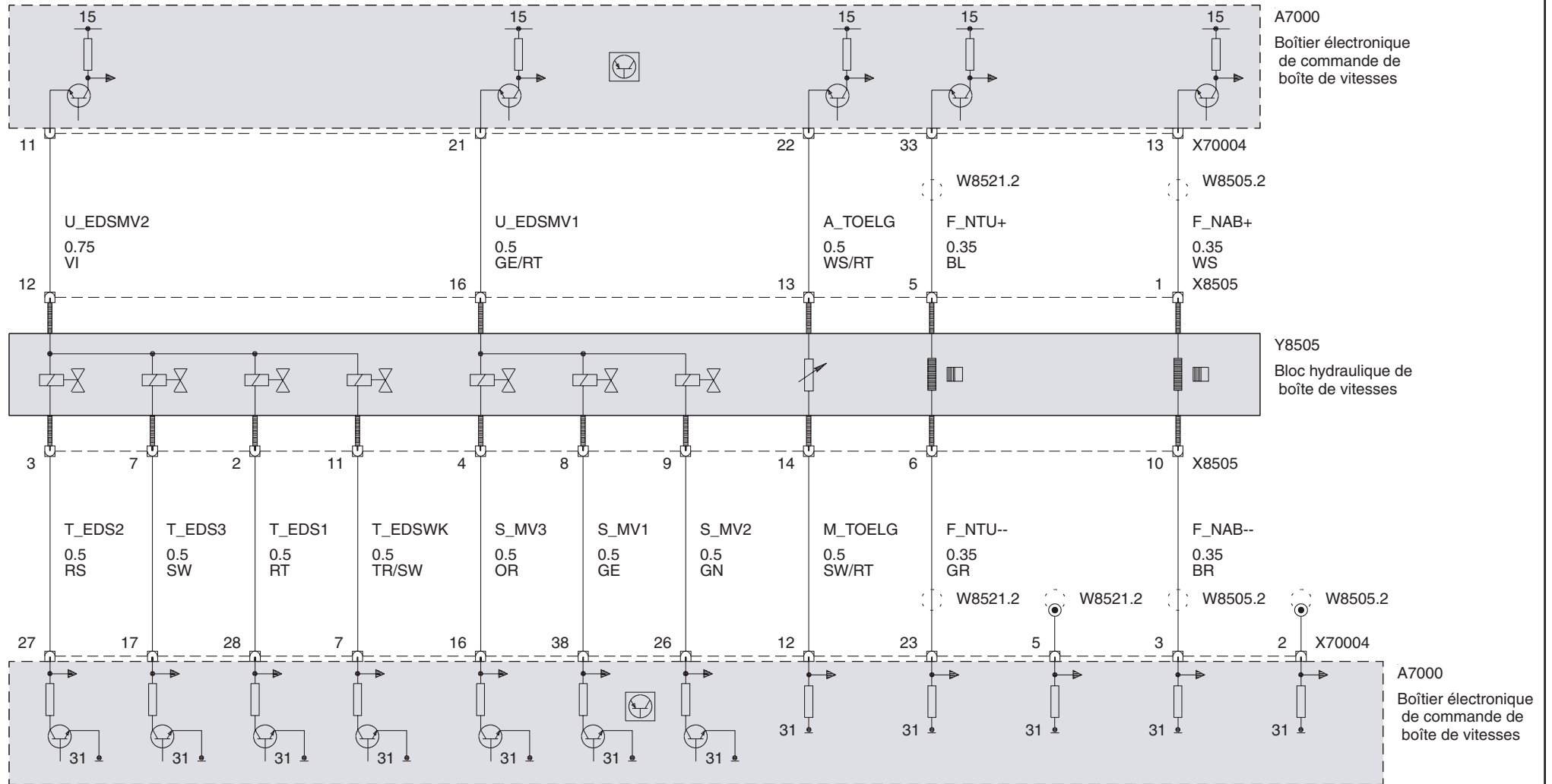

# Commande de boîte de vitesses SMG (Boîte de vitesses manuelle séquentielle)

## Commande boîte de vitesses (jusqu'au 2002\_09)

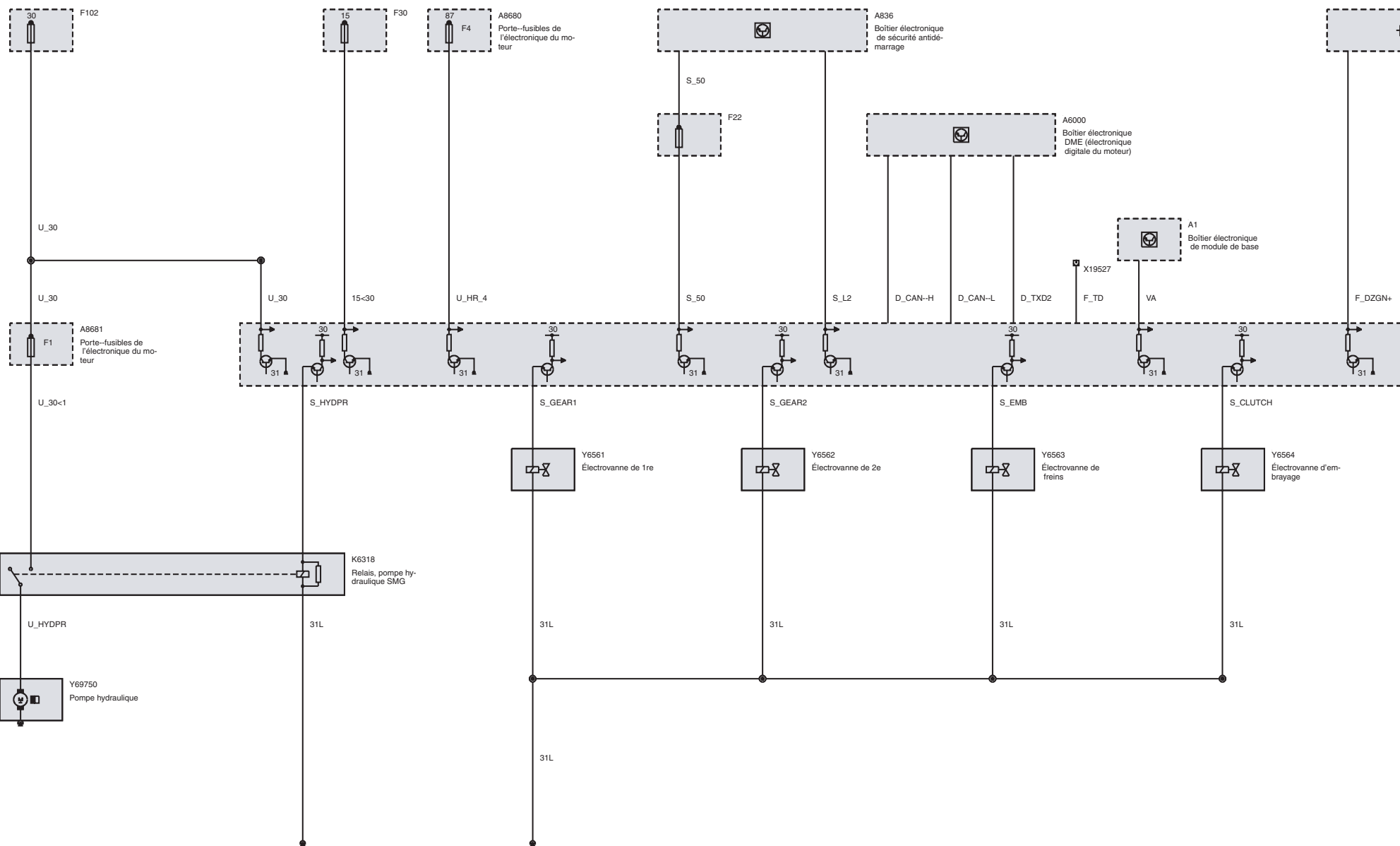

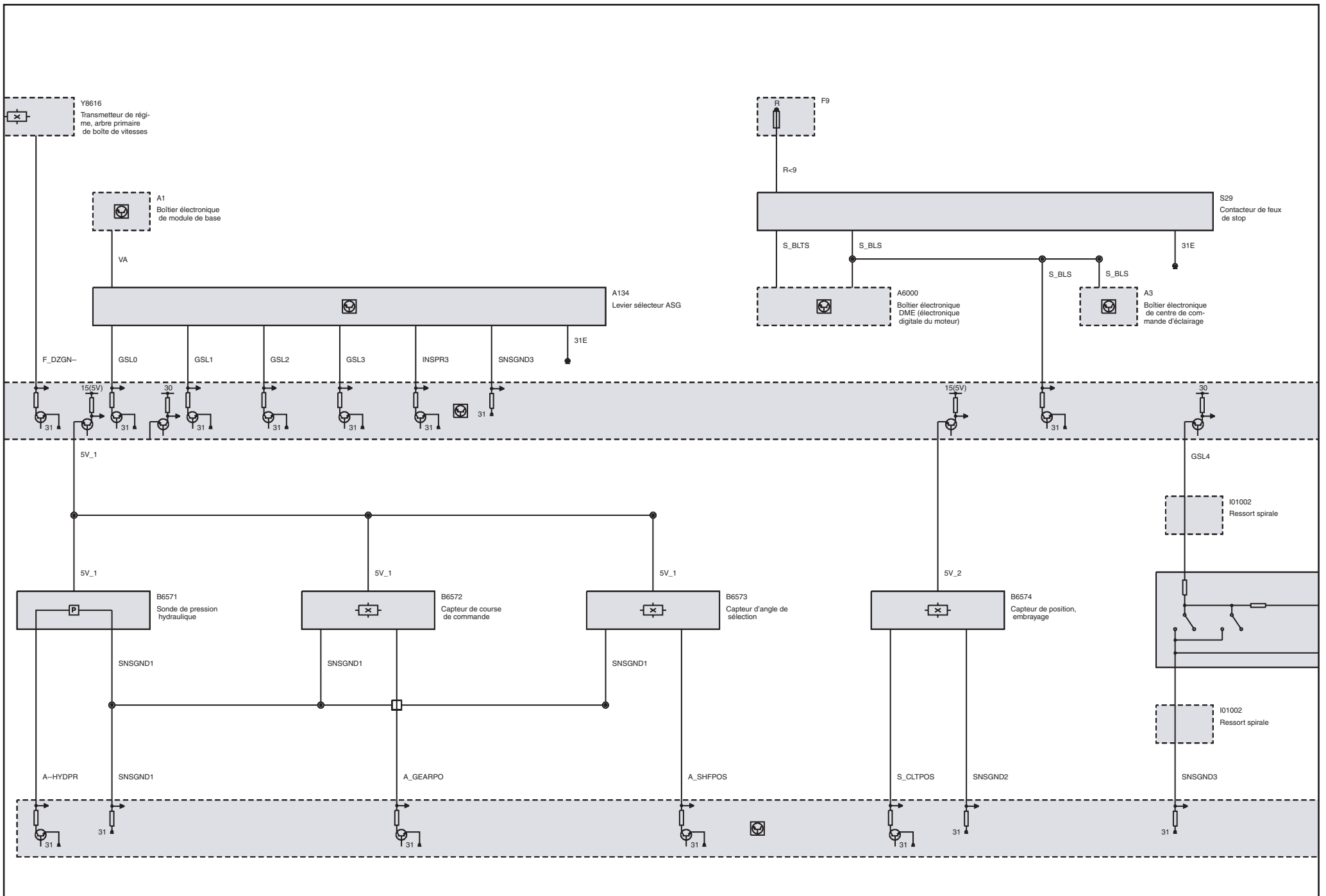

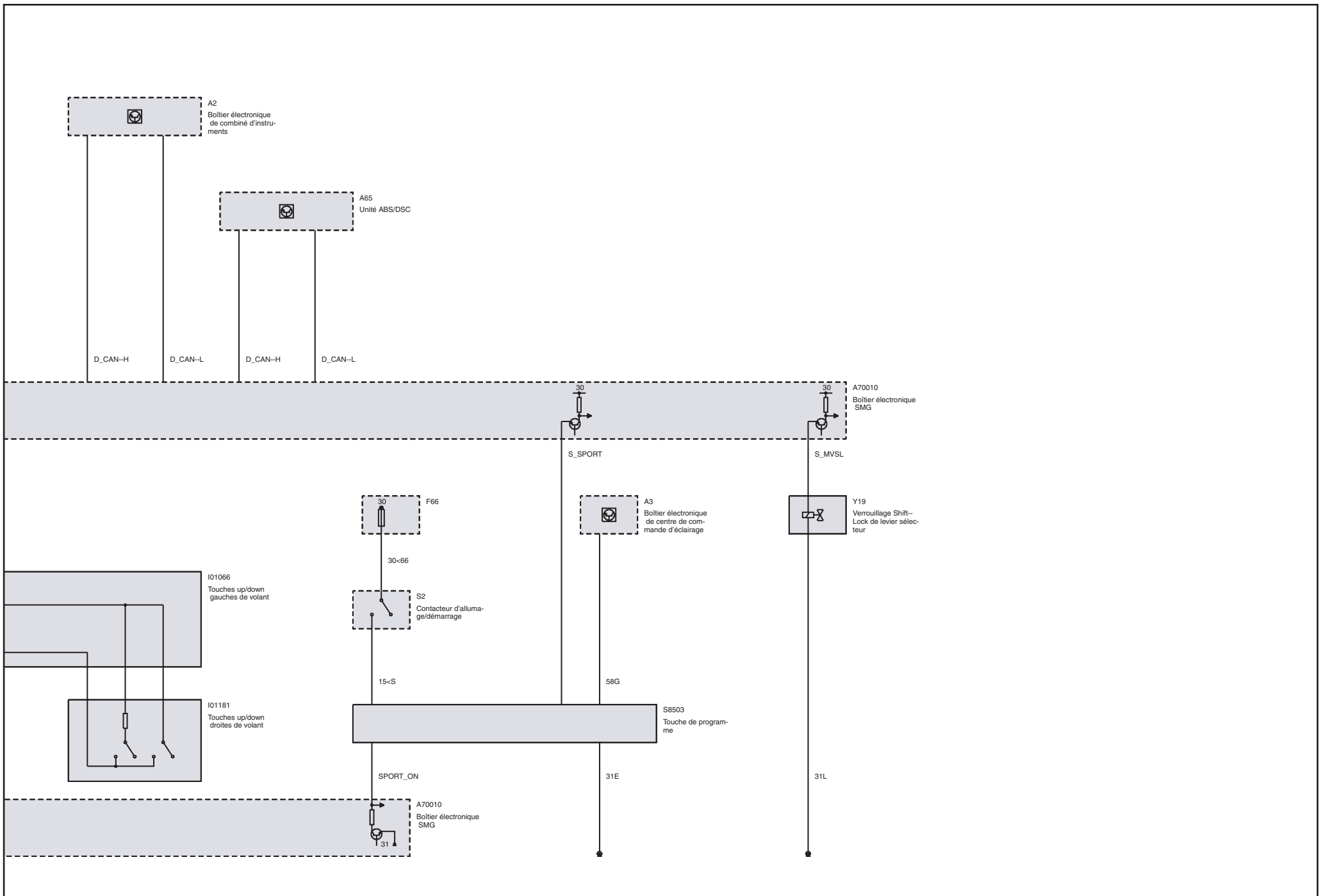

Commande boîte de vitesses (à partir de 2002\_09 jusque 2003\_03)

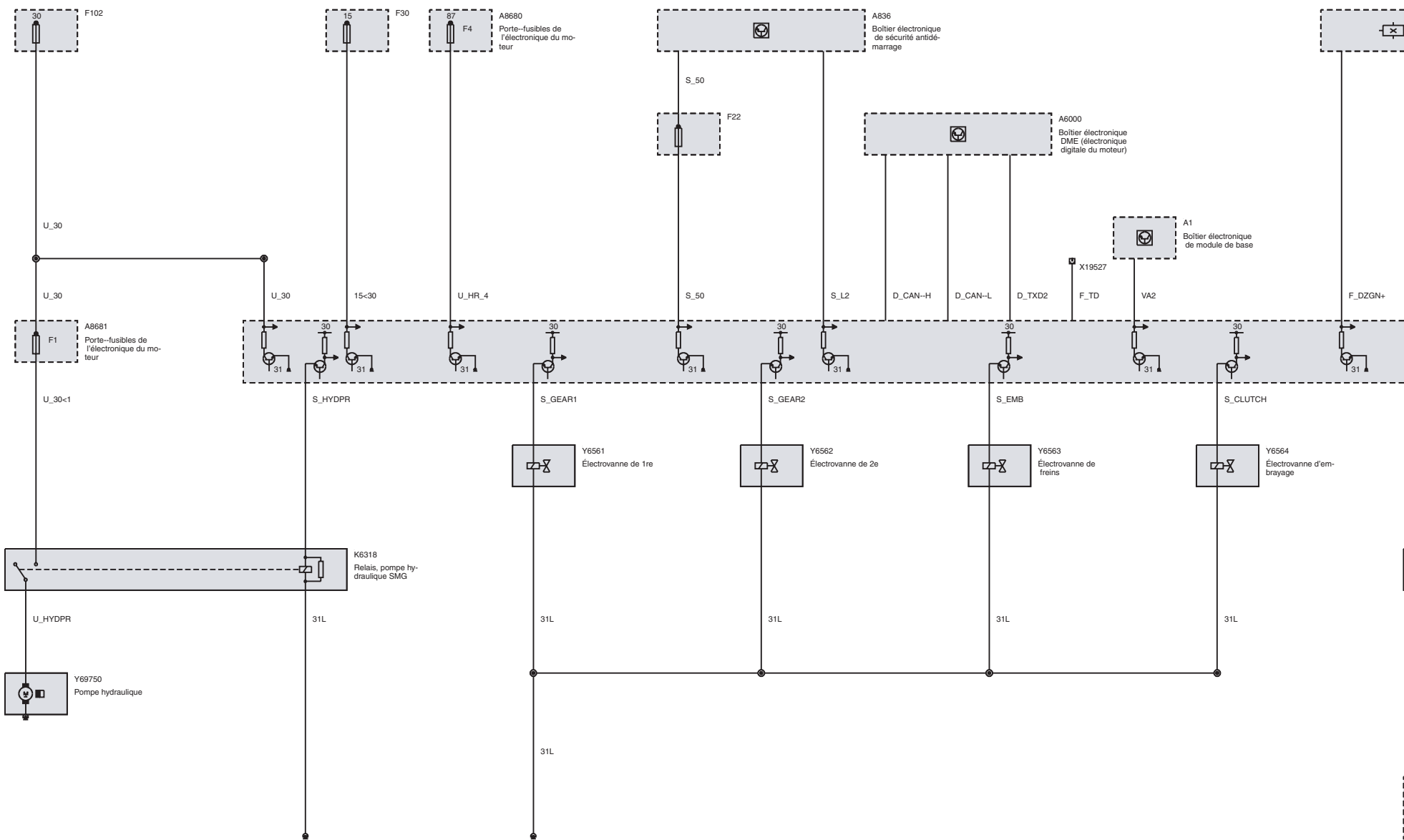

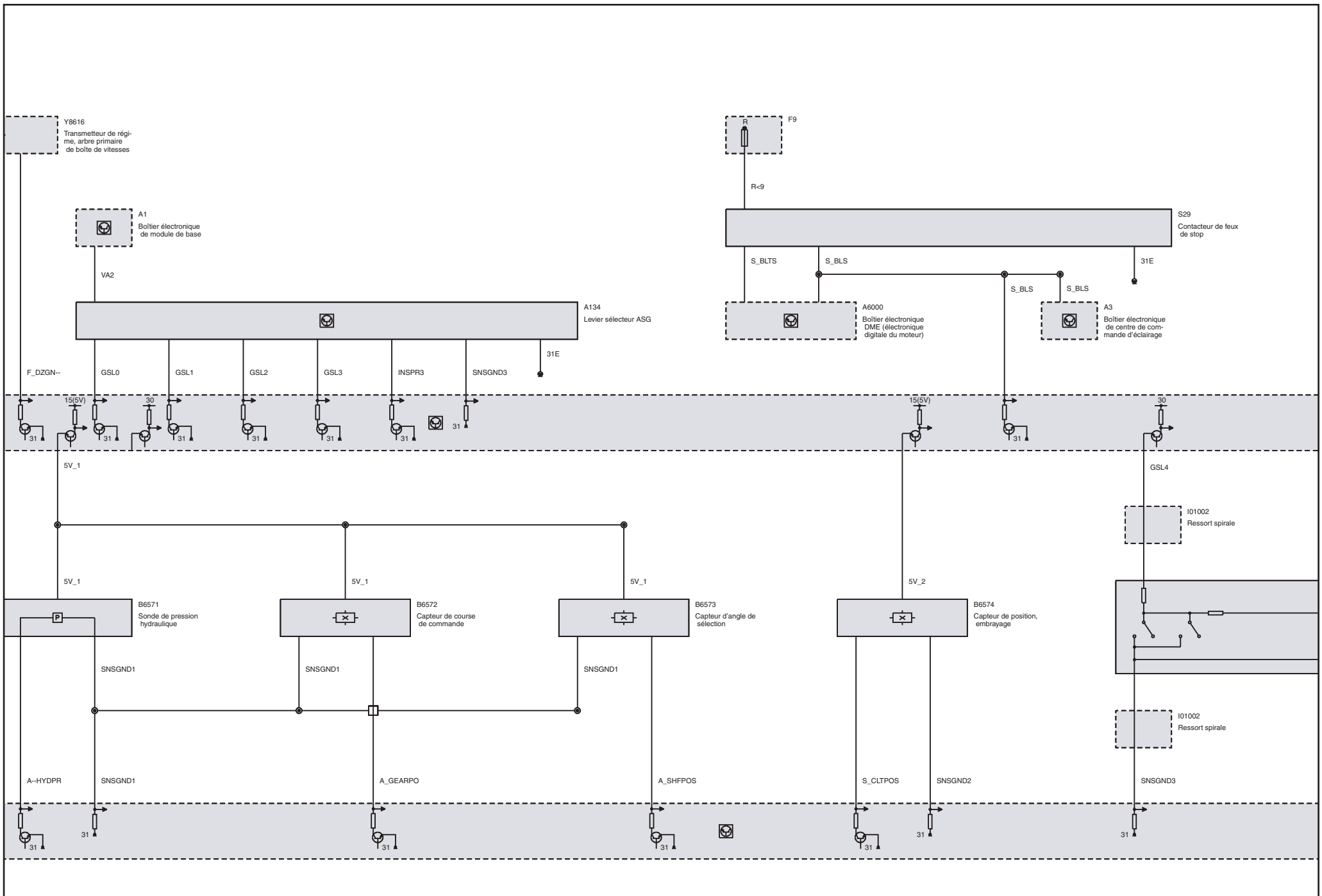



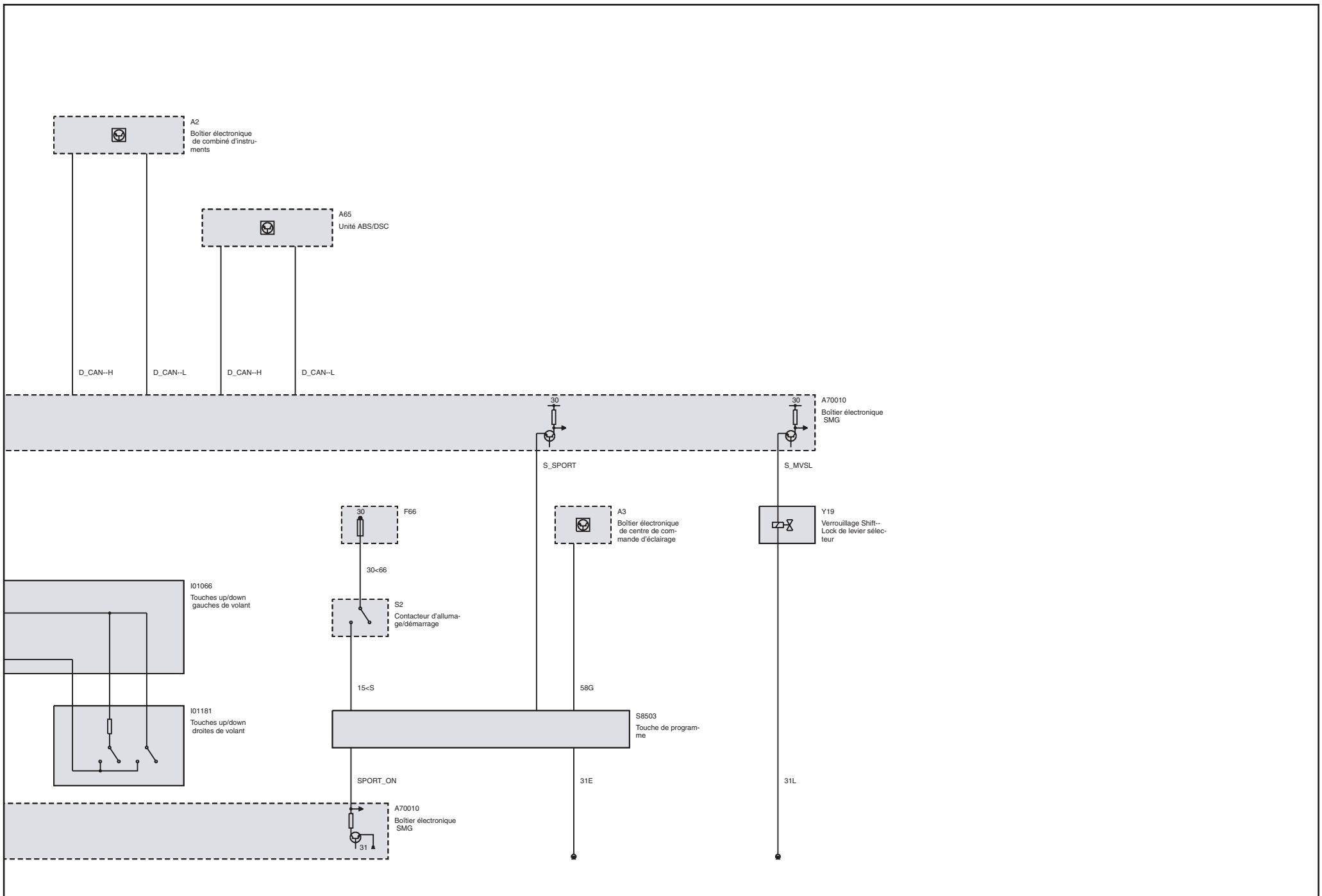

Commande boîte de vitesses (à partir de 2003\_03)

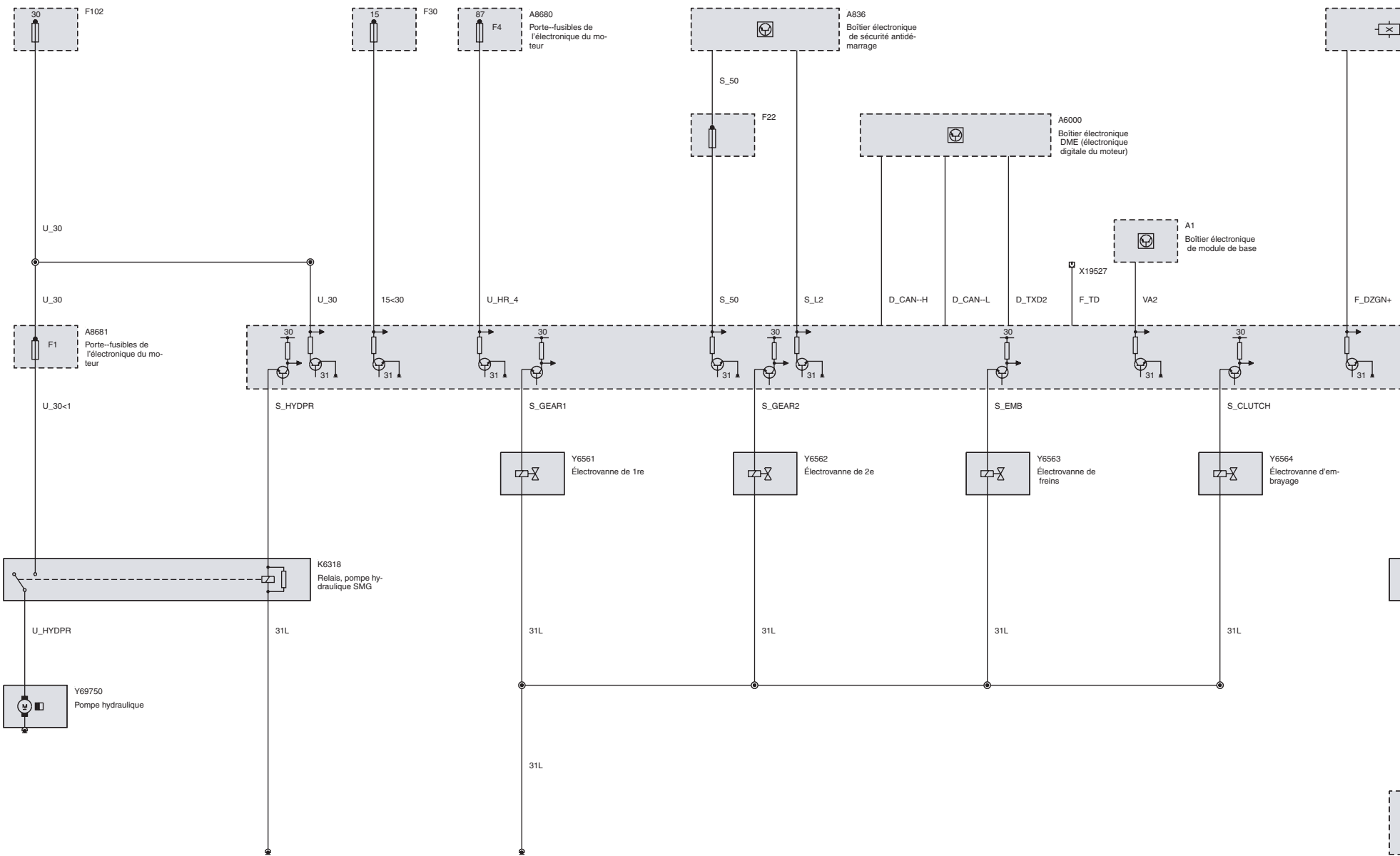

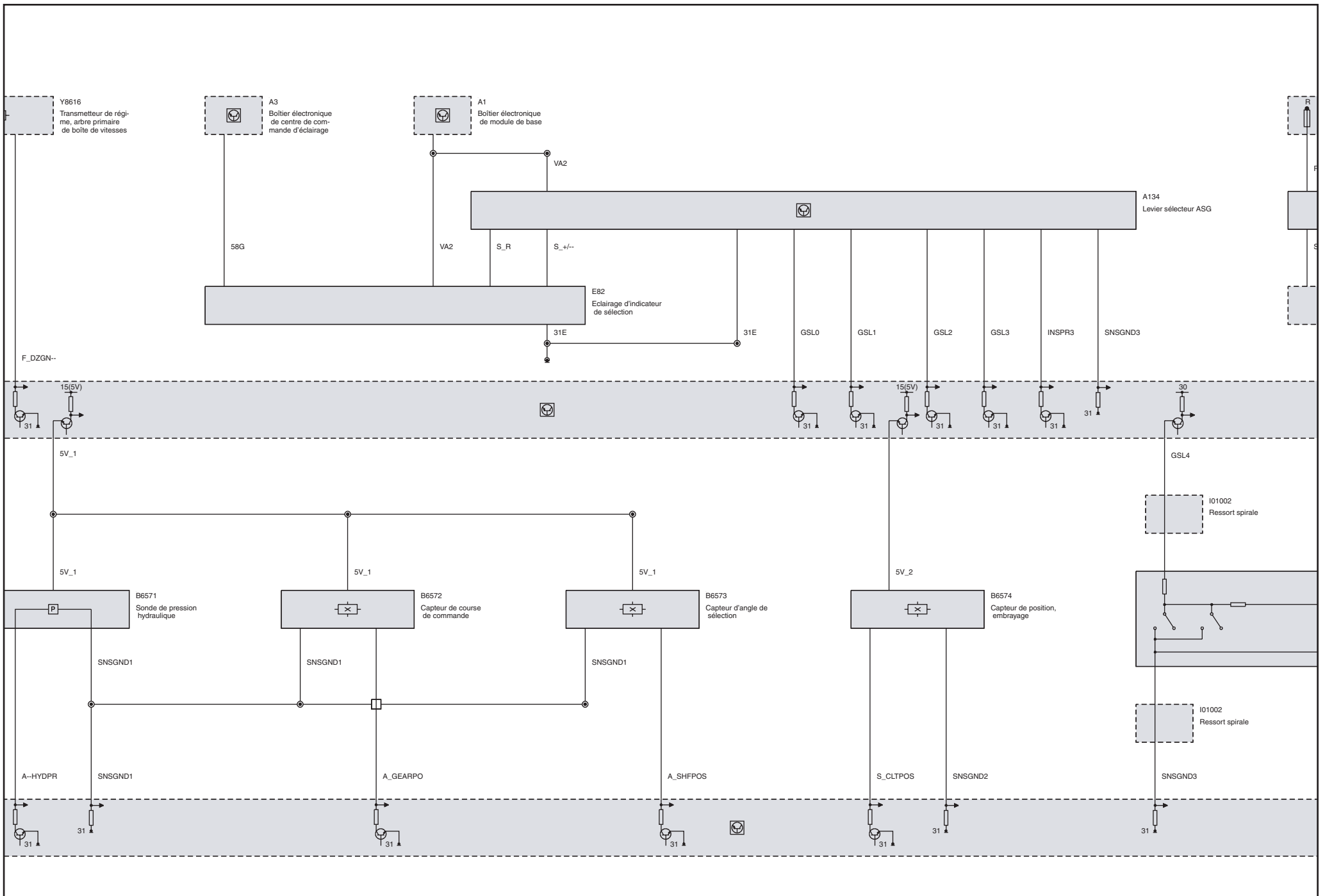

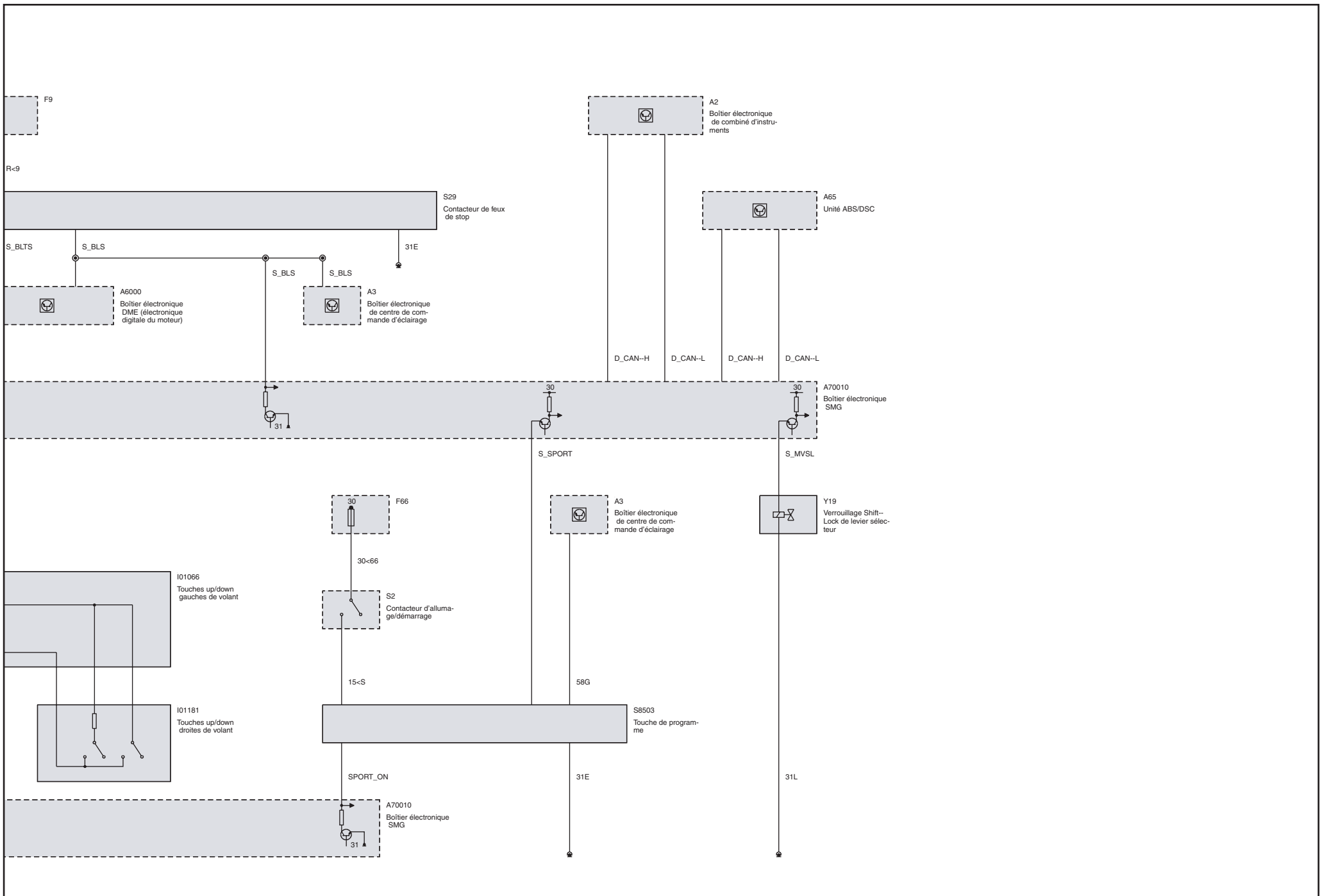

Interfaces SMG

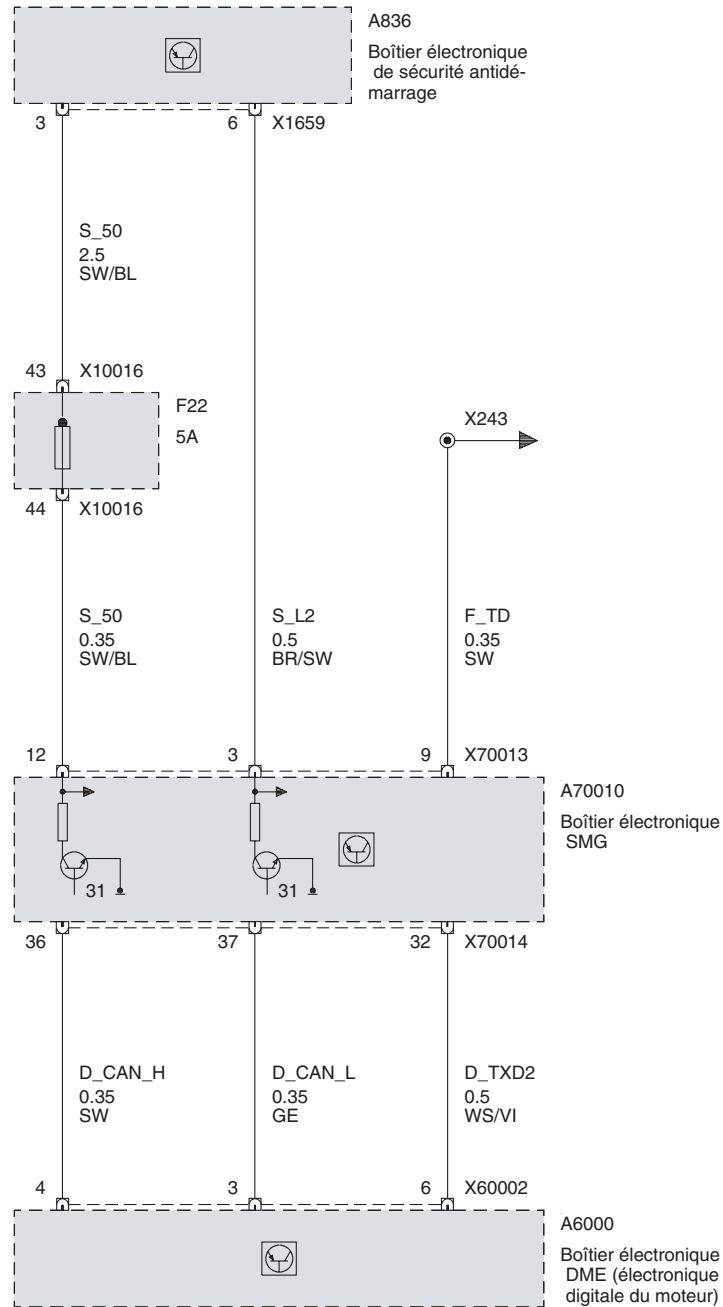

### Commutateur fonction boîte séquentielle Manettes de sélection de rapport

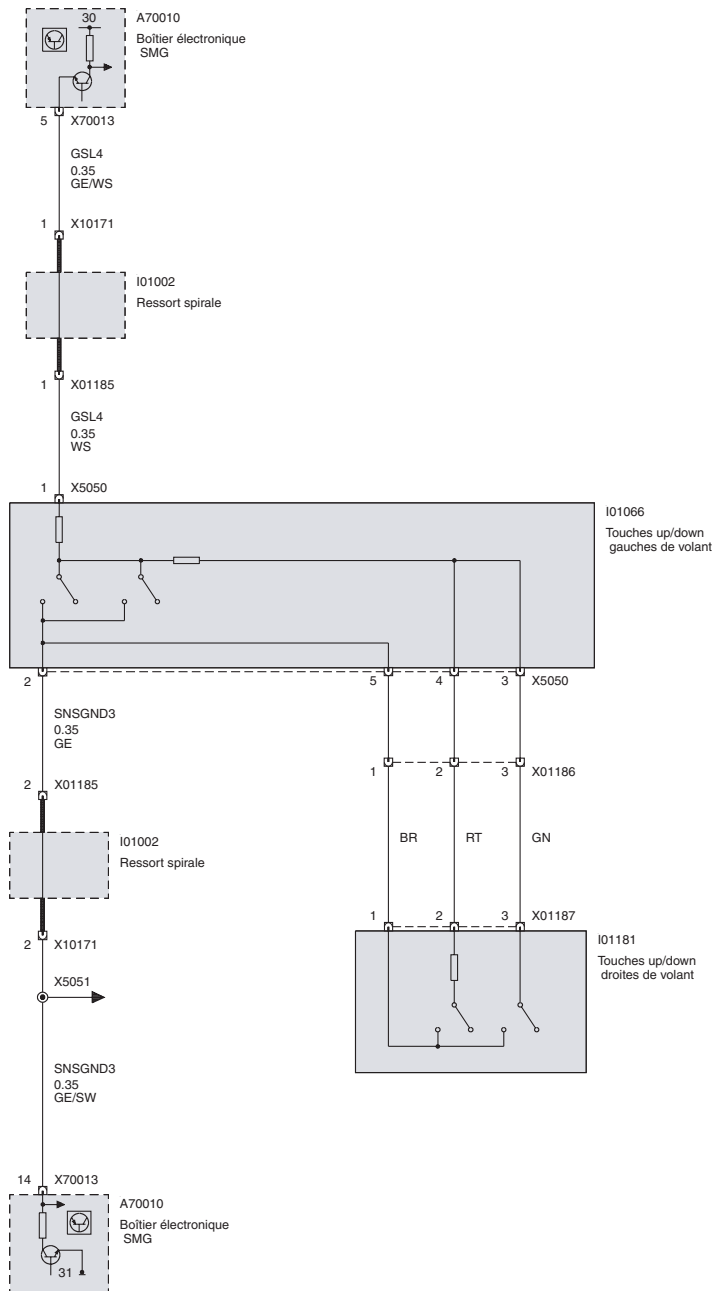

Touche sport

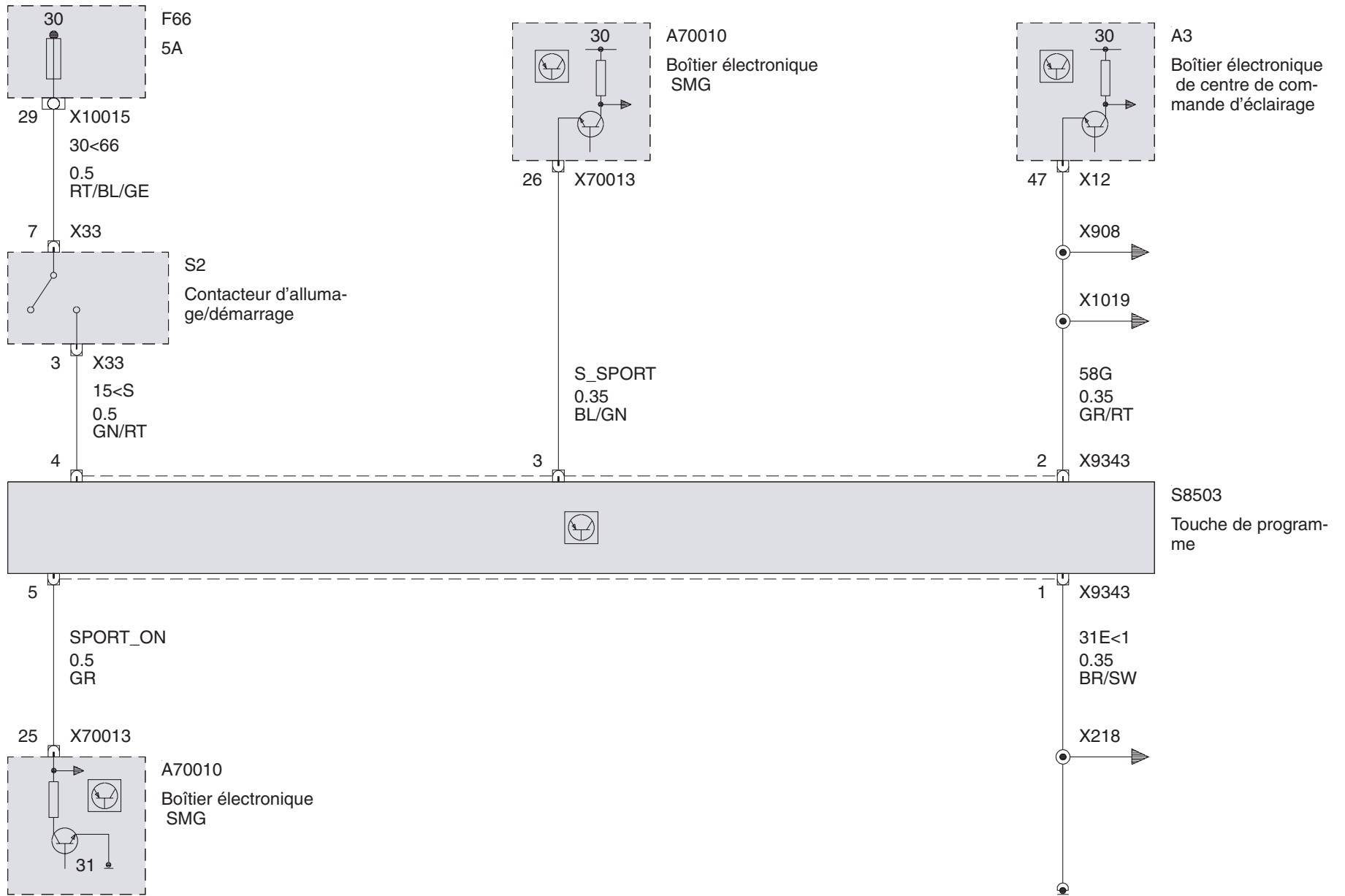

Capteurs de position rapport

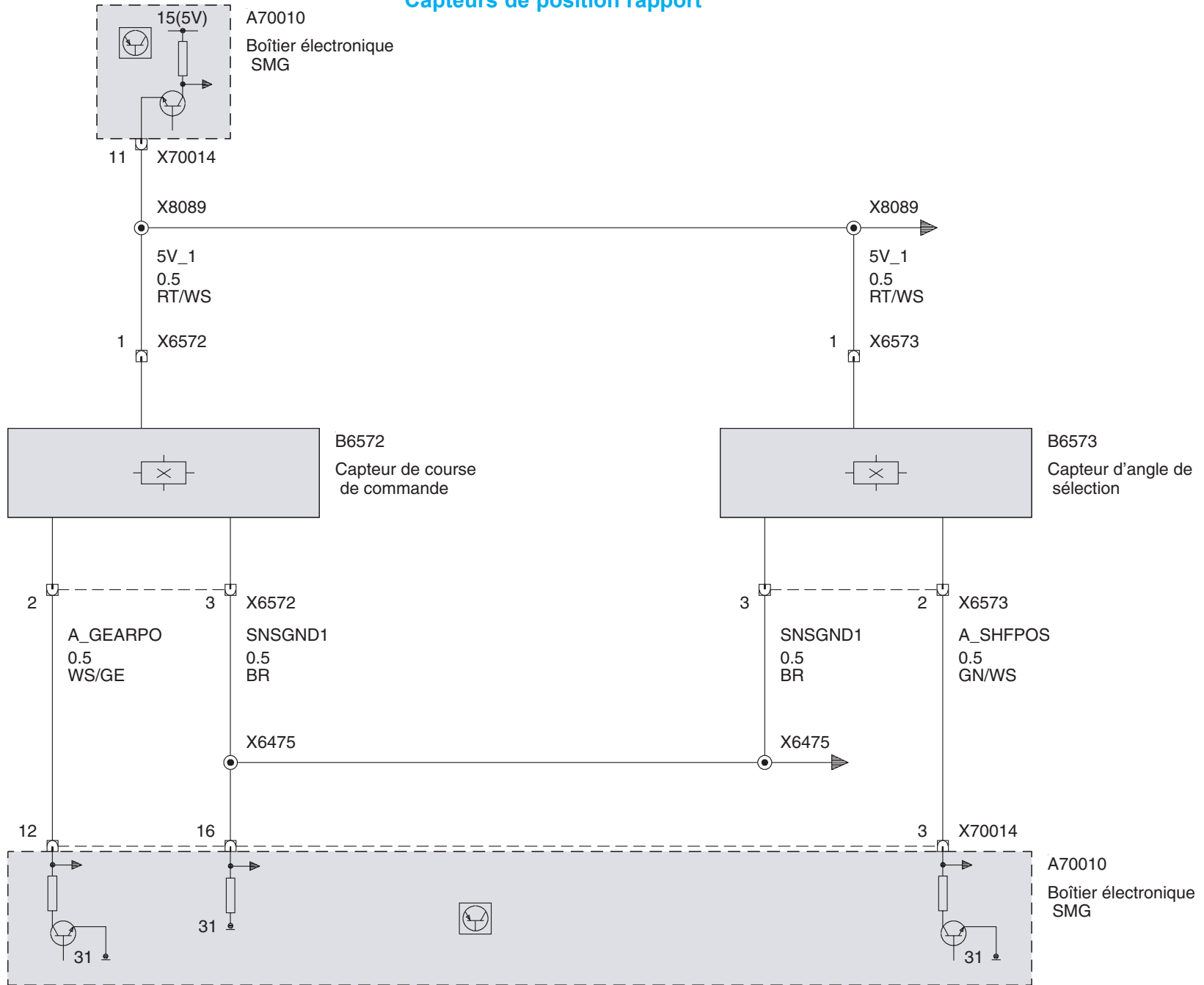



Unité hydraulique  
Installation hydraulique SMG (jusque 2003\_03)

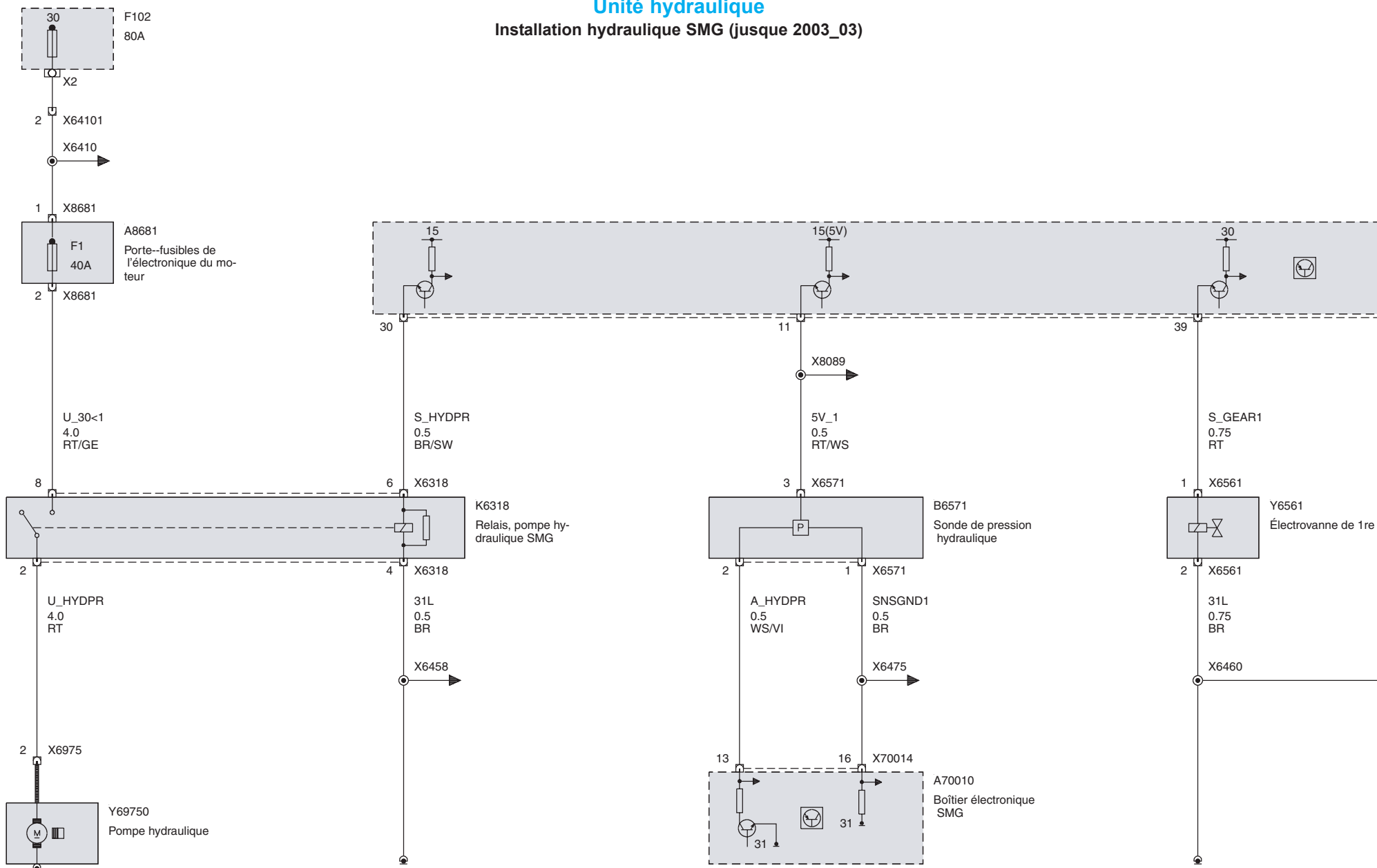

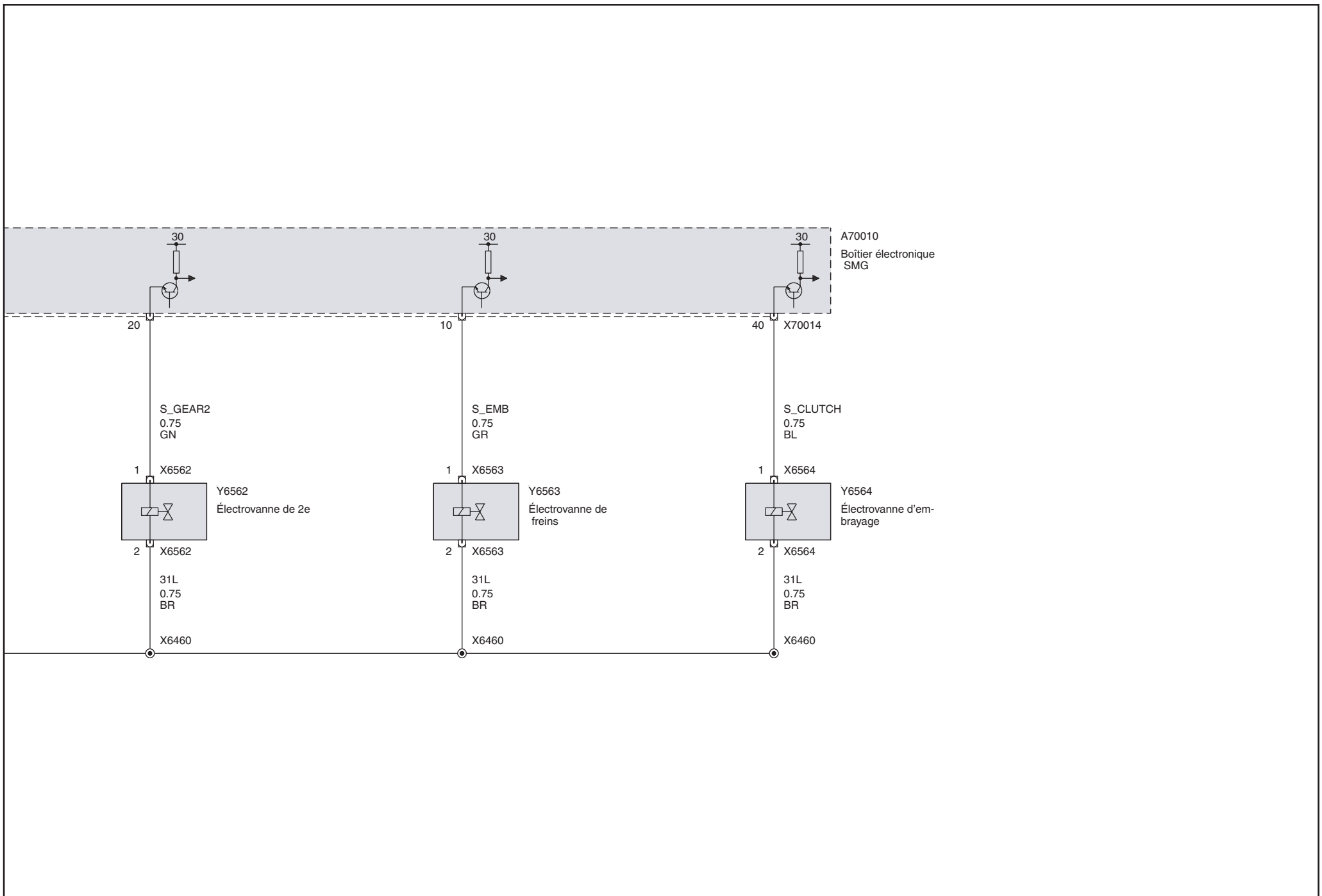

Installation hydraulique SMG (à partir de 2003\_03)

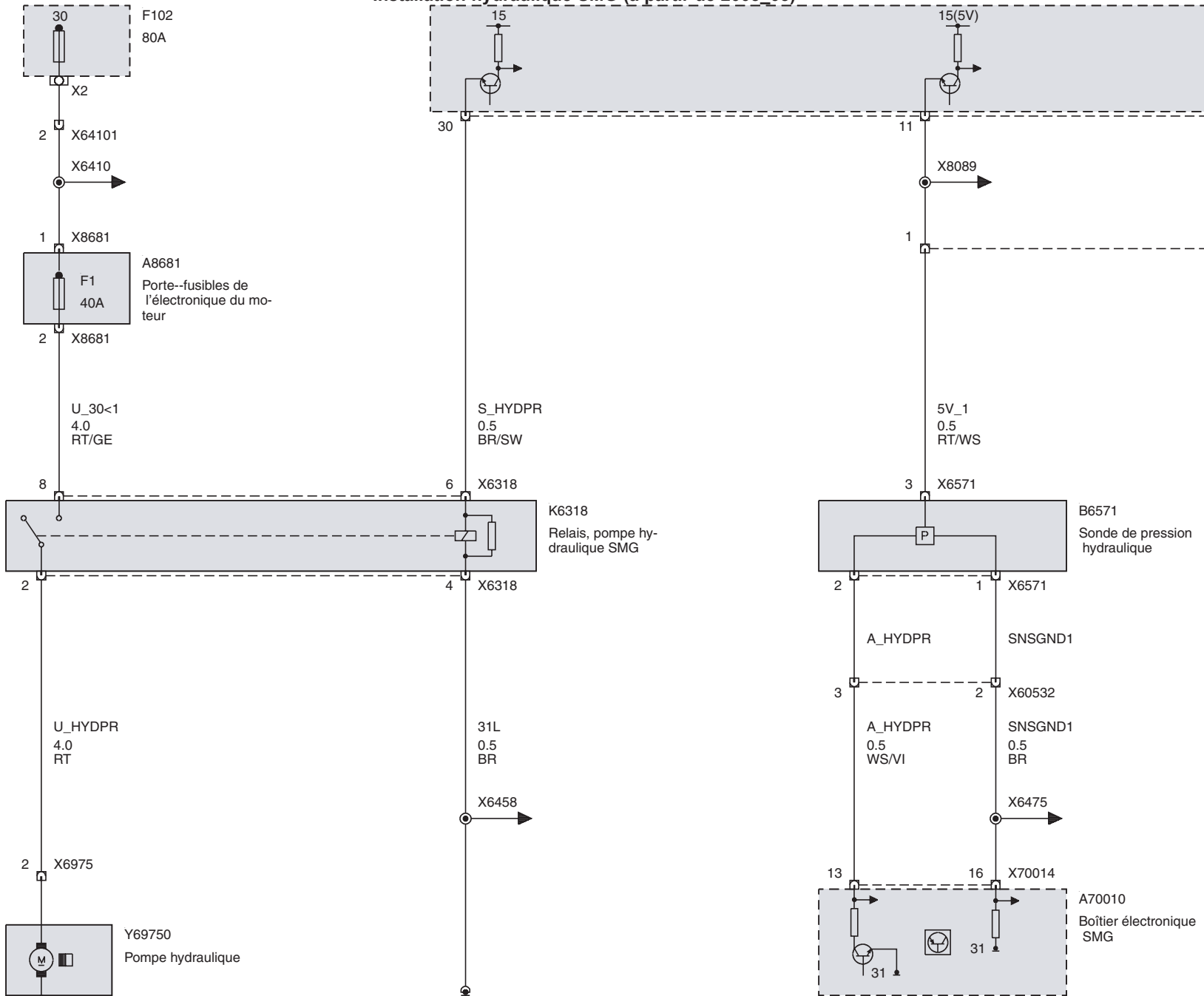

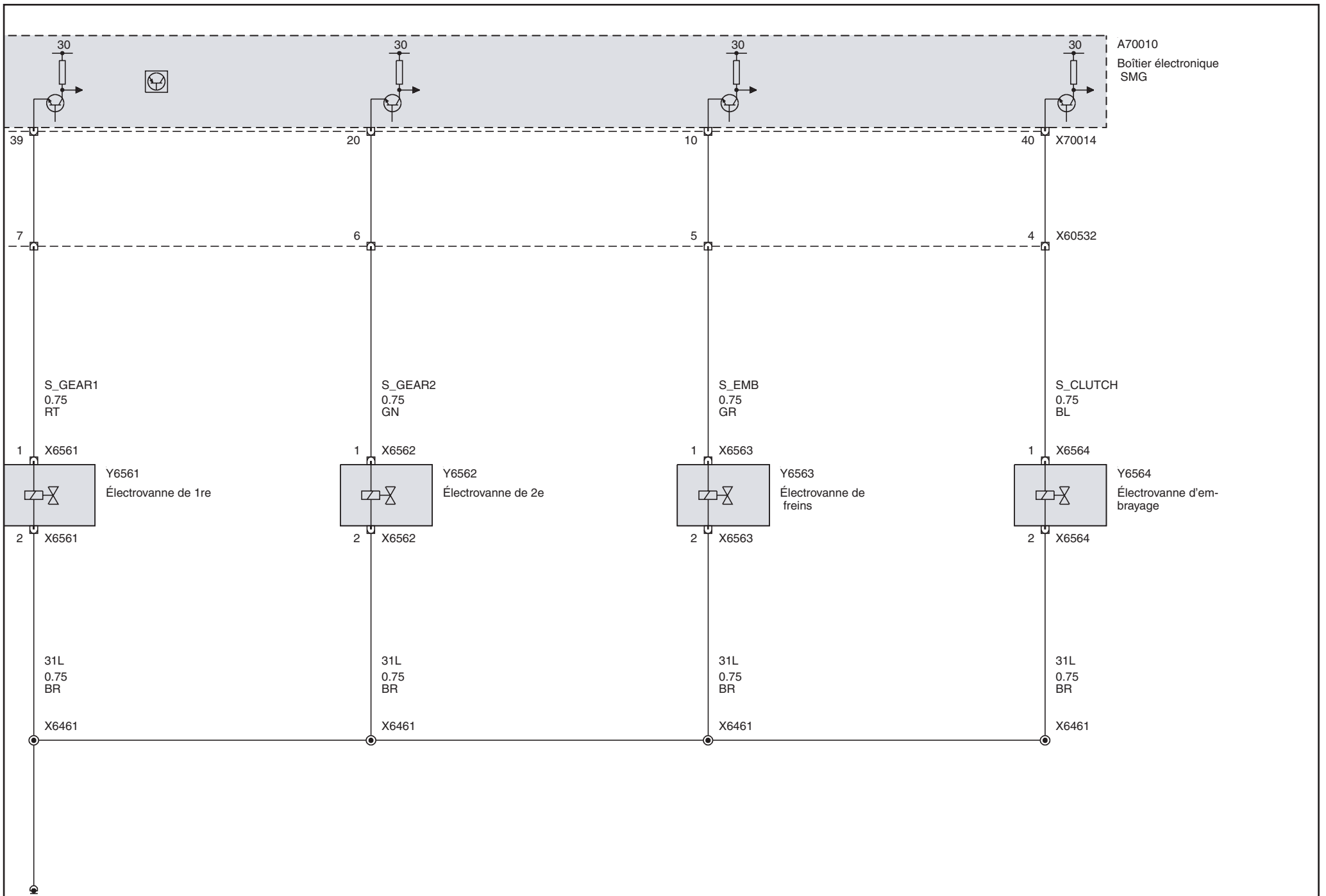

**Embrayage**

**Position d'embrayage**

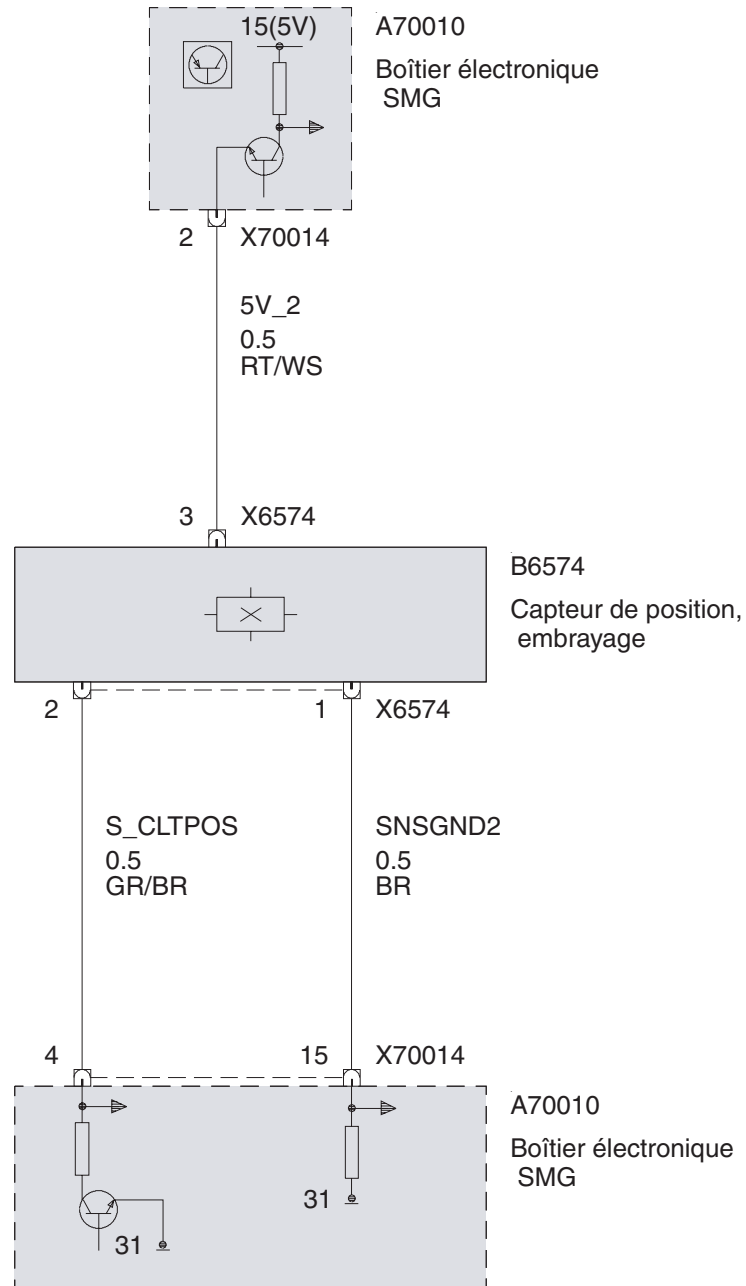

Régime, arbre primaire de boîte de vitesses

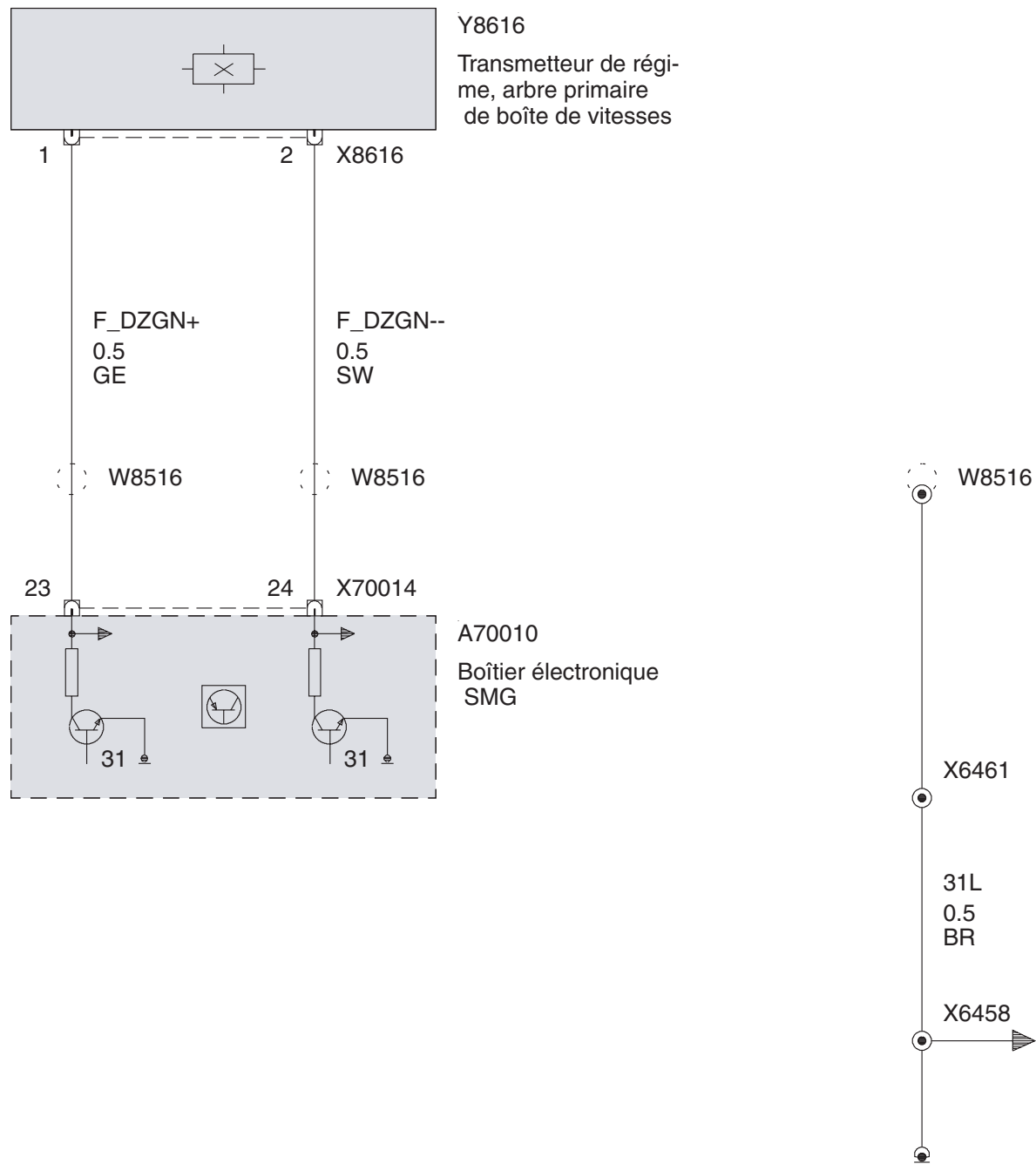

**Boîtier électronique**  
Alimentation (jusque 2002\_09)

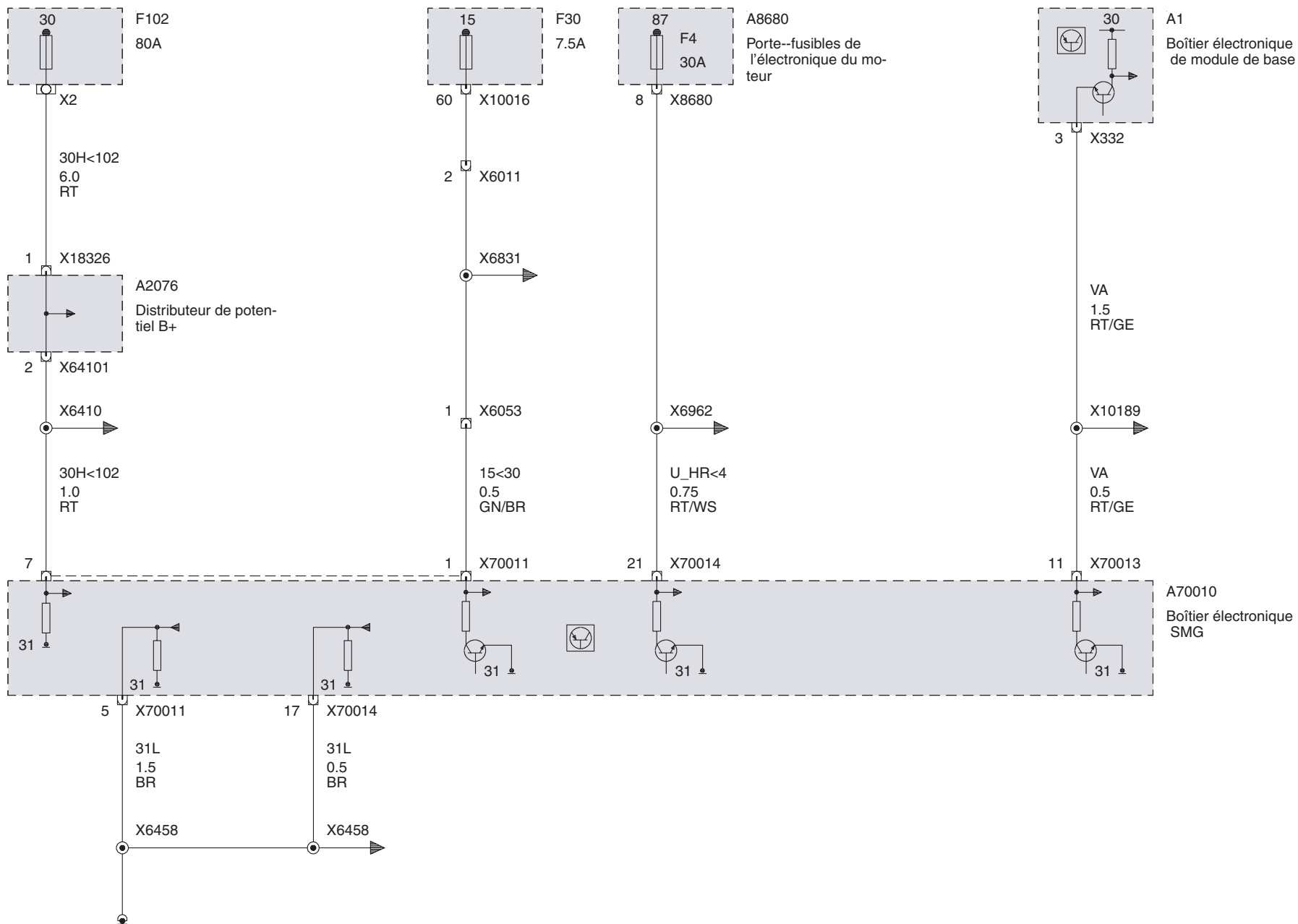

Alimentation (à partir de 2002\_09)

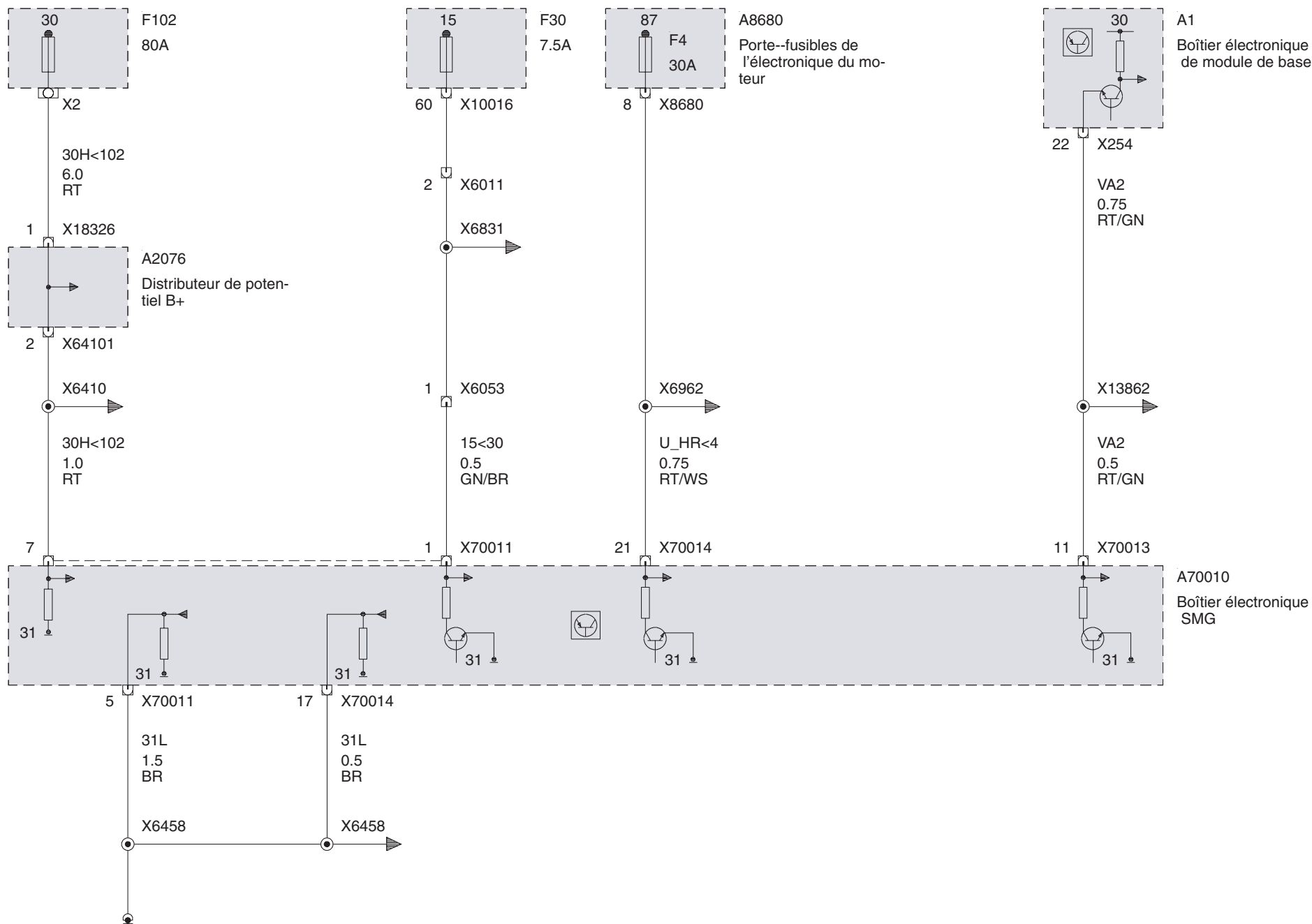



**Levier sélecteur**  
Levier sélecteur (jusque 2002\_09)

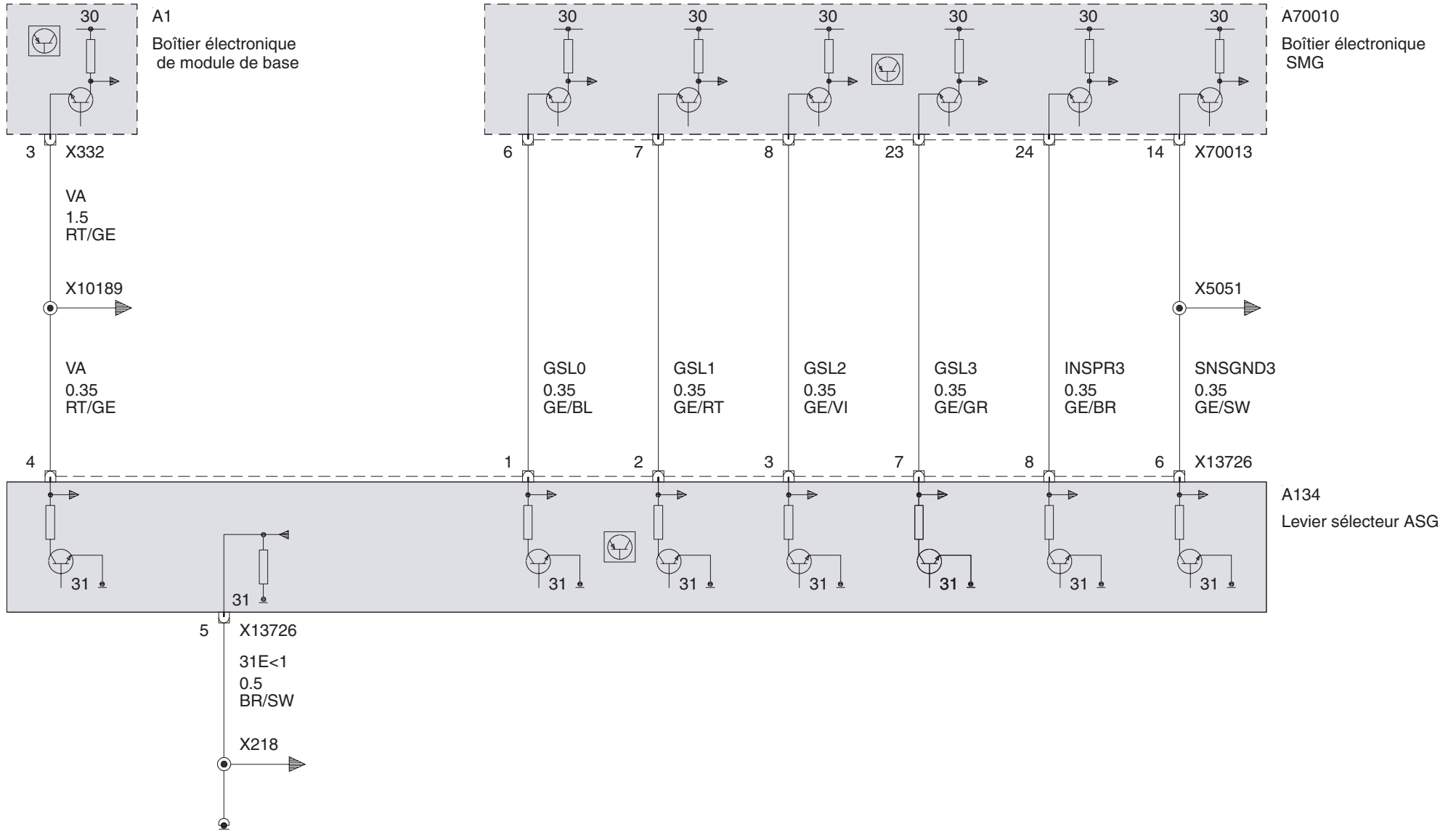

Levier sélecteur (à partir de 2002\_09 jusque 2003\_03)

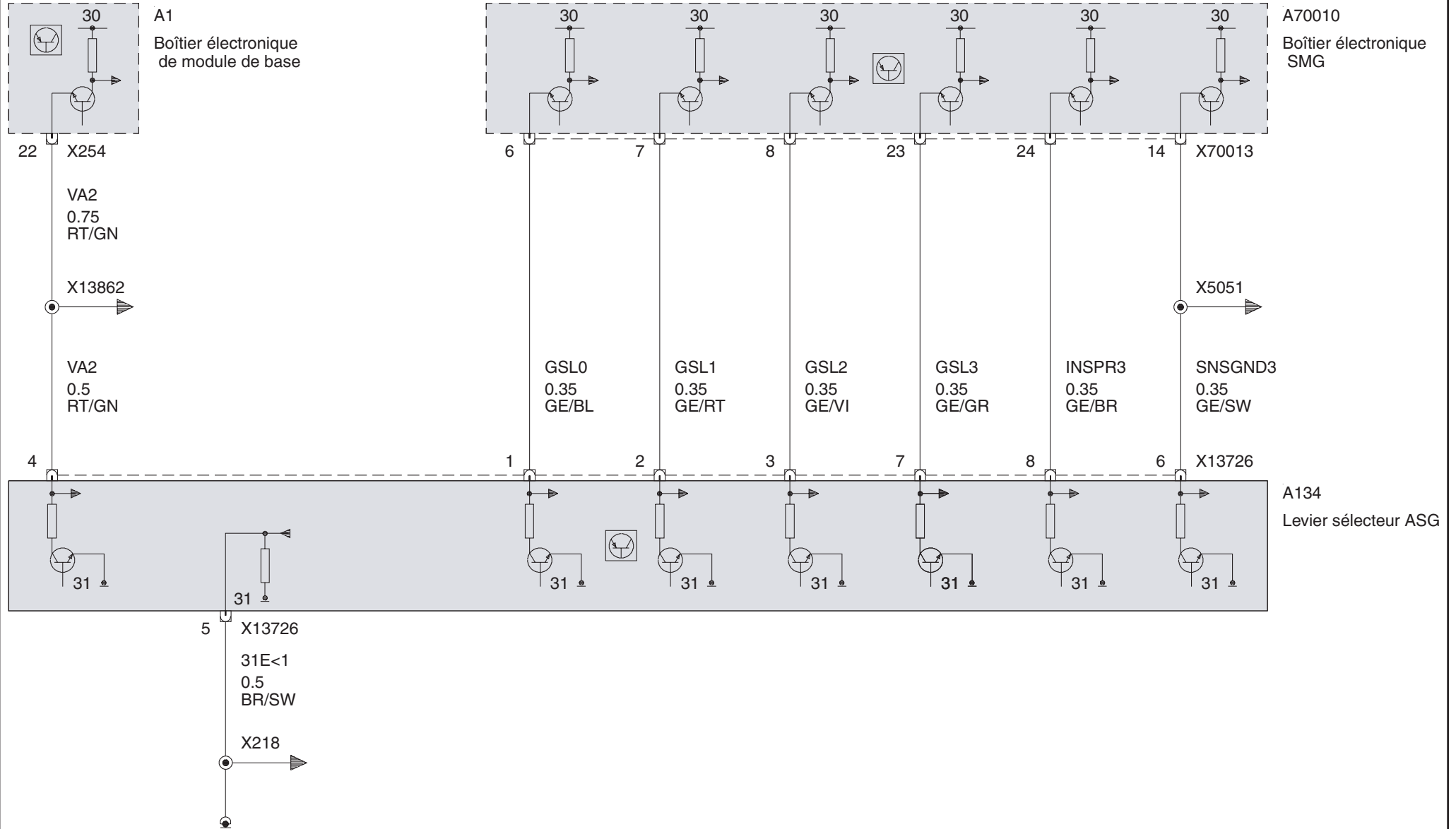

Levier sélecteur (à partir de 2003\_03)

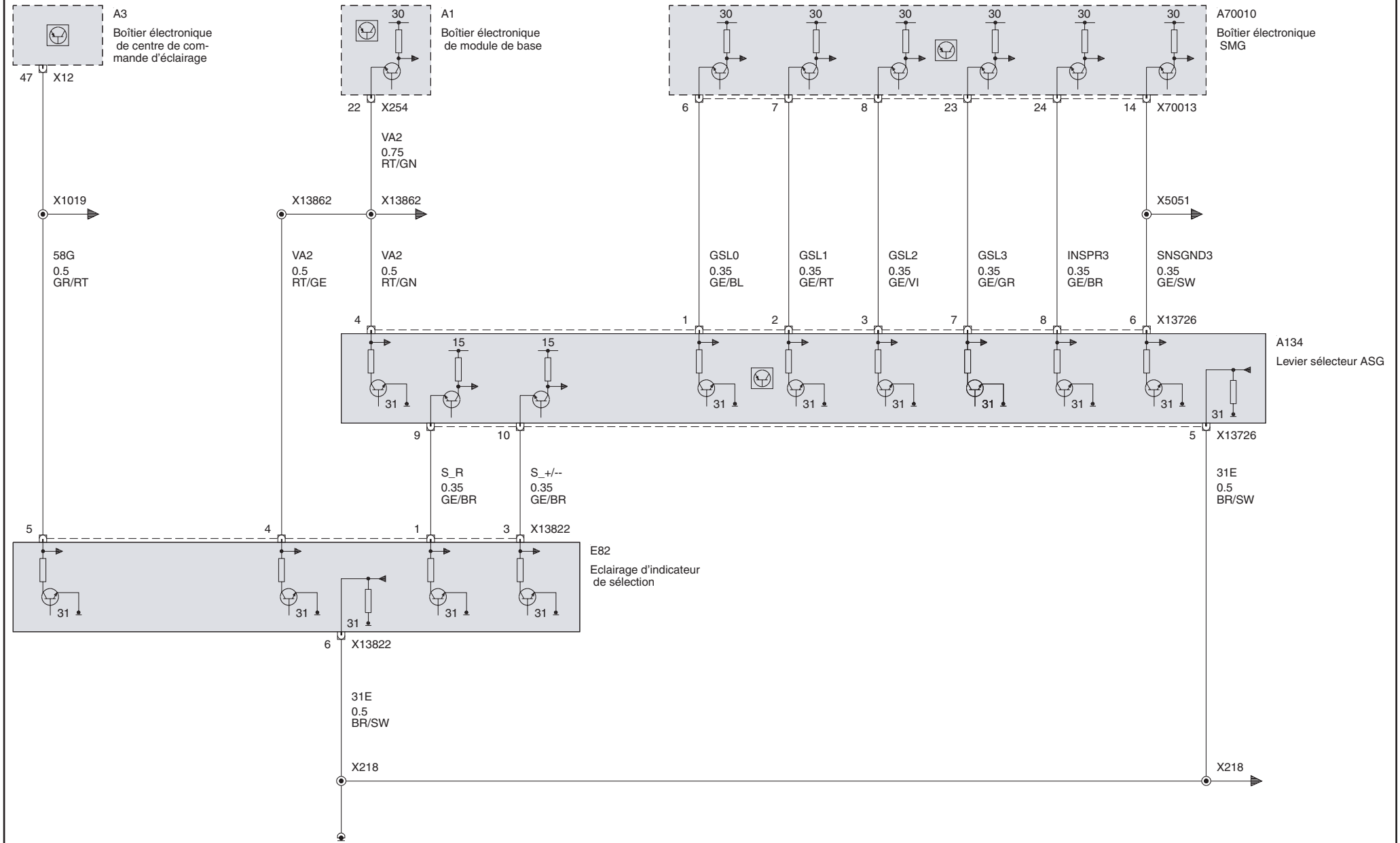

Verrouillage Shift-Lock de levier sélecteur

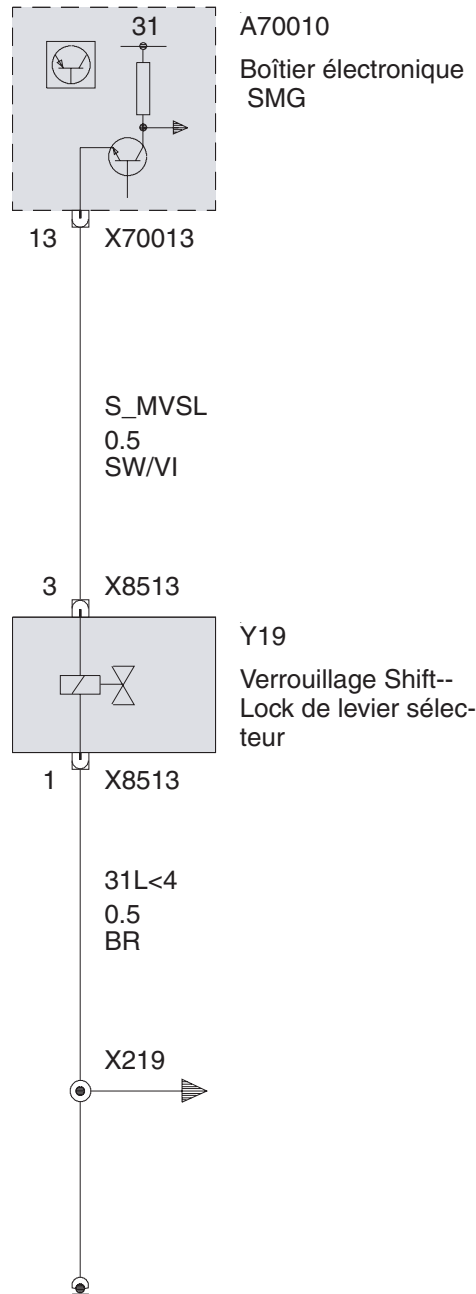

### Génération de tension et de courant

#### Régulation de tension et de courant

Régulation de tension et de courant (Essence)

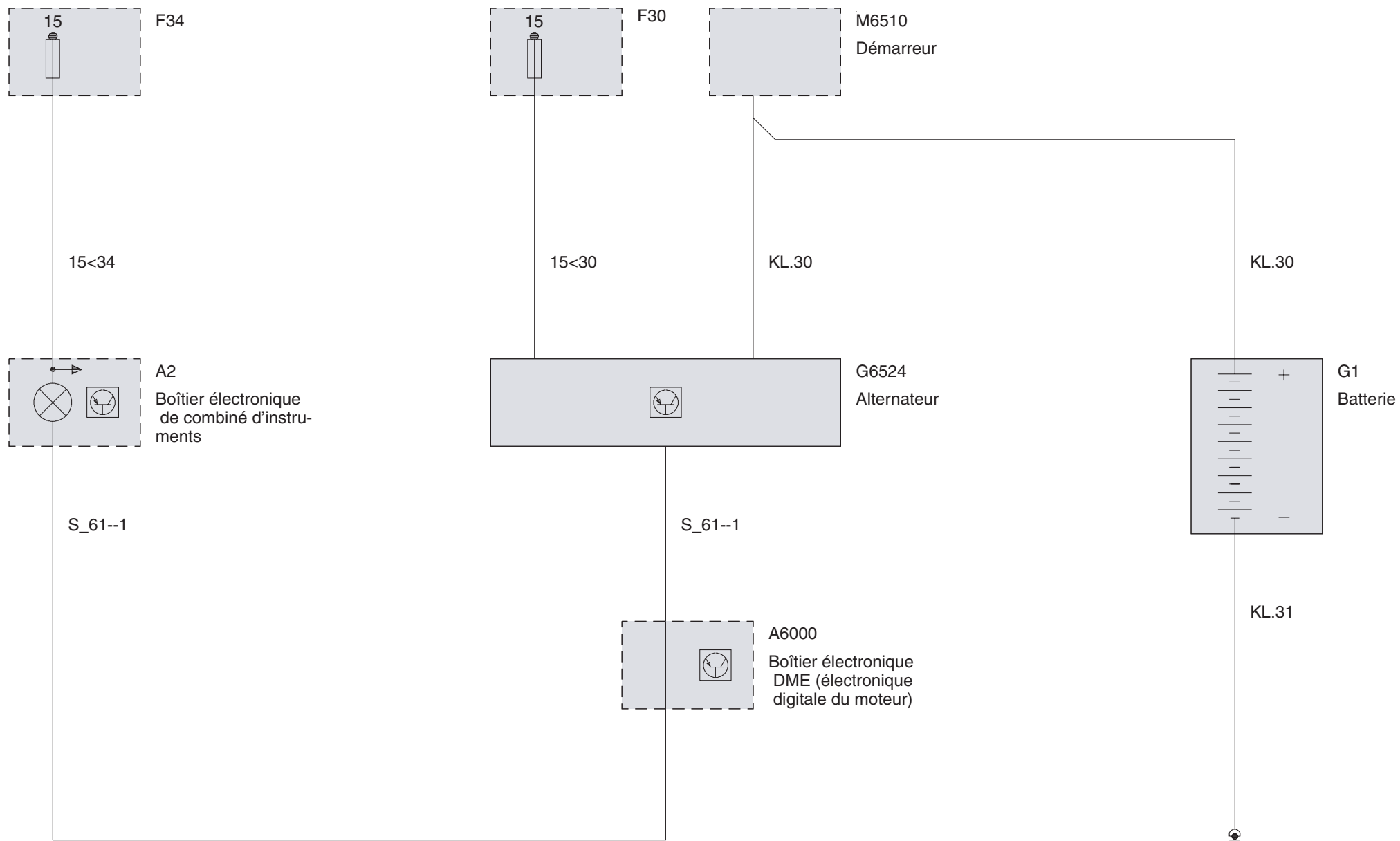

Régulation de tension et de courant (Diesel)

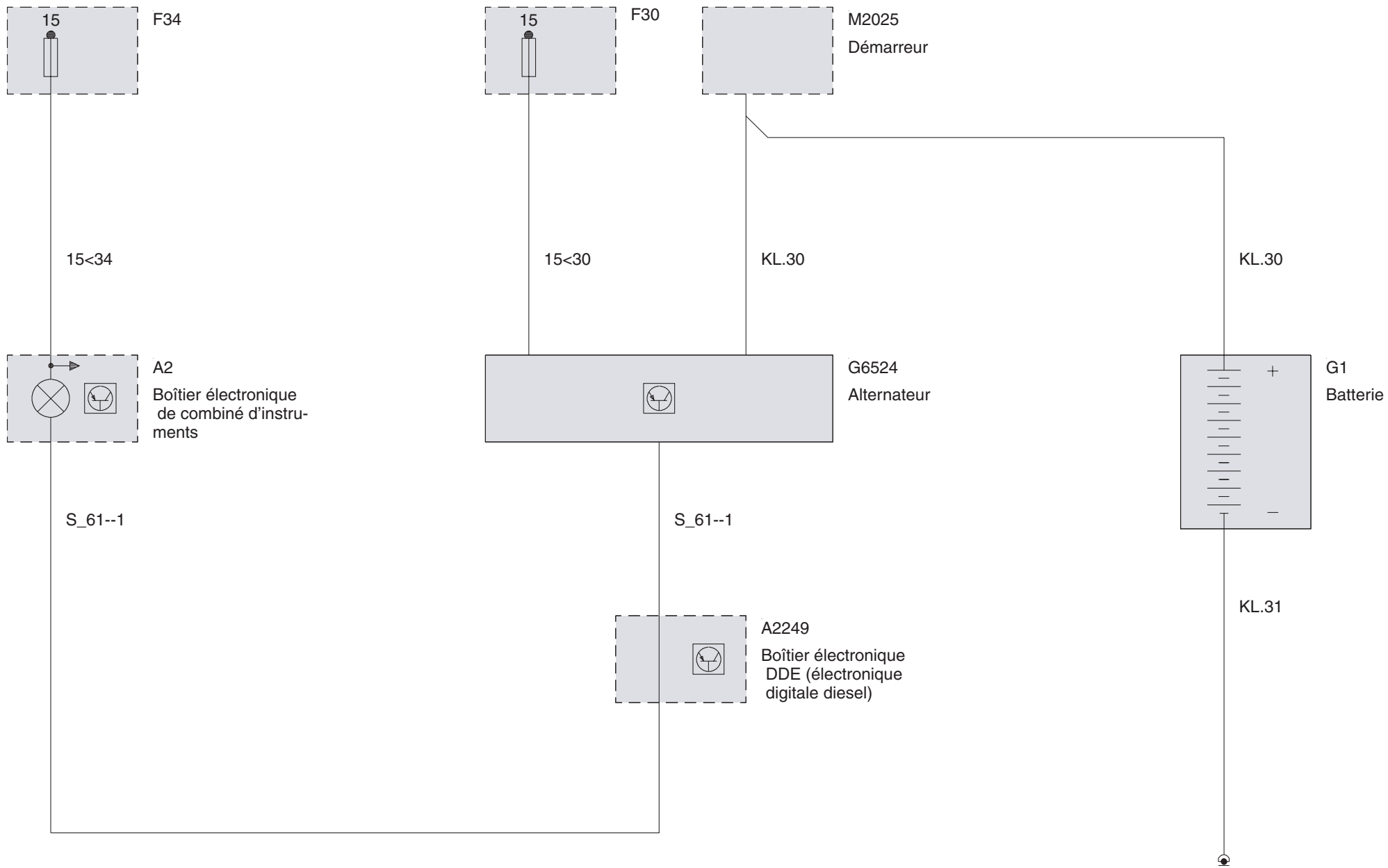

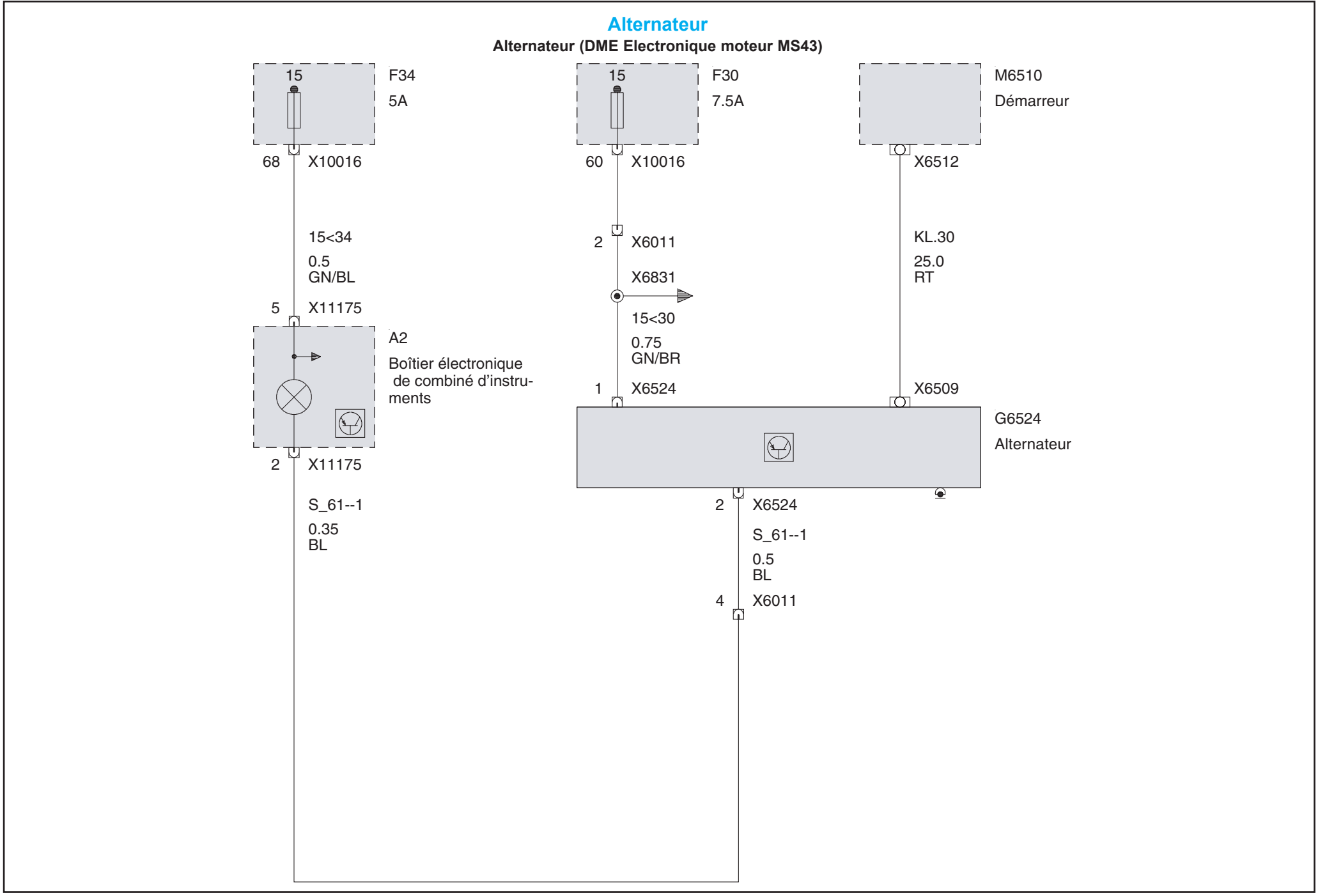

Alternateur (DME Electronique moteur ME9)

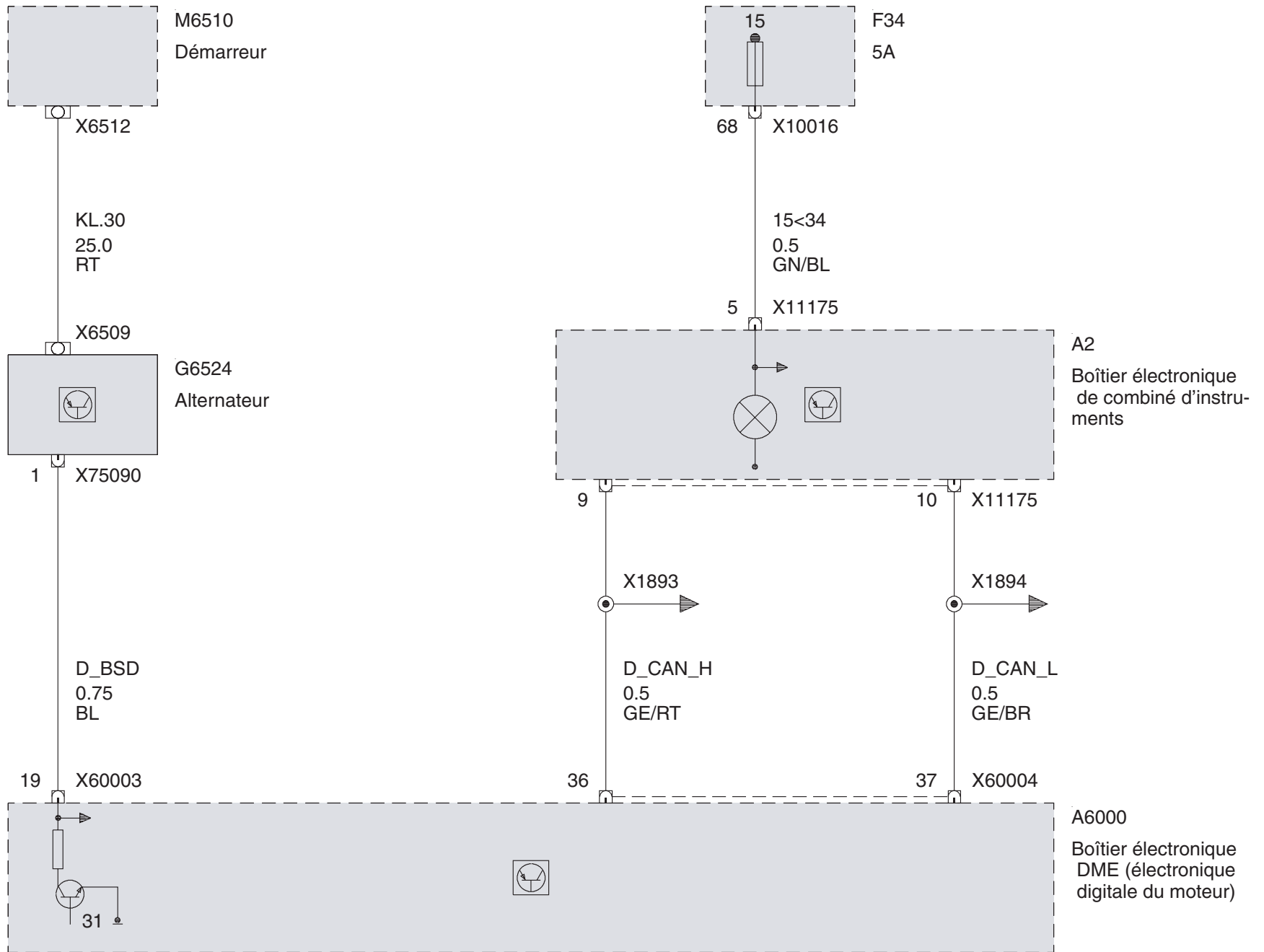



Alternateur (DDE Electronique Diesel DDE50)

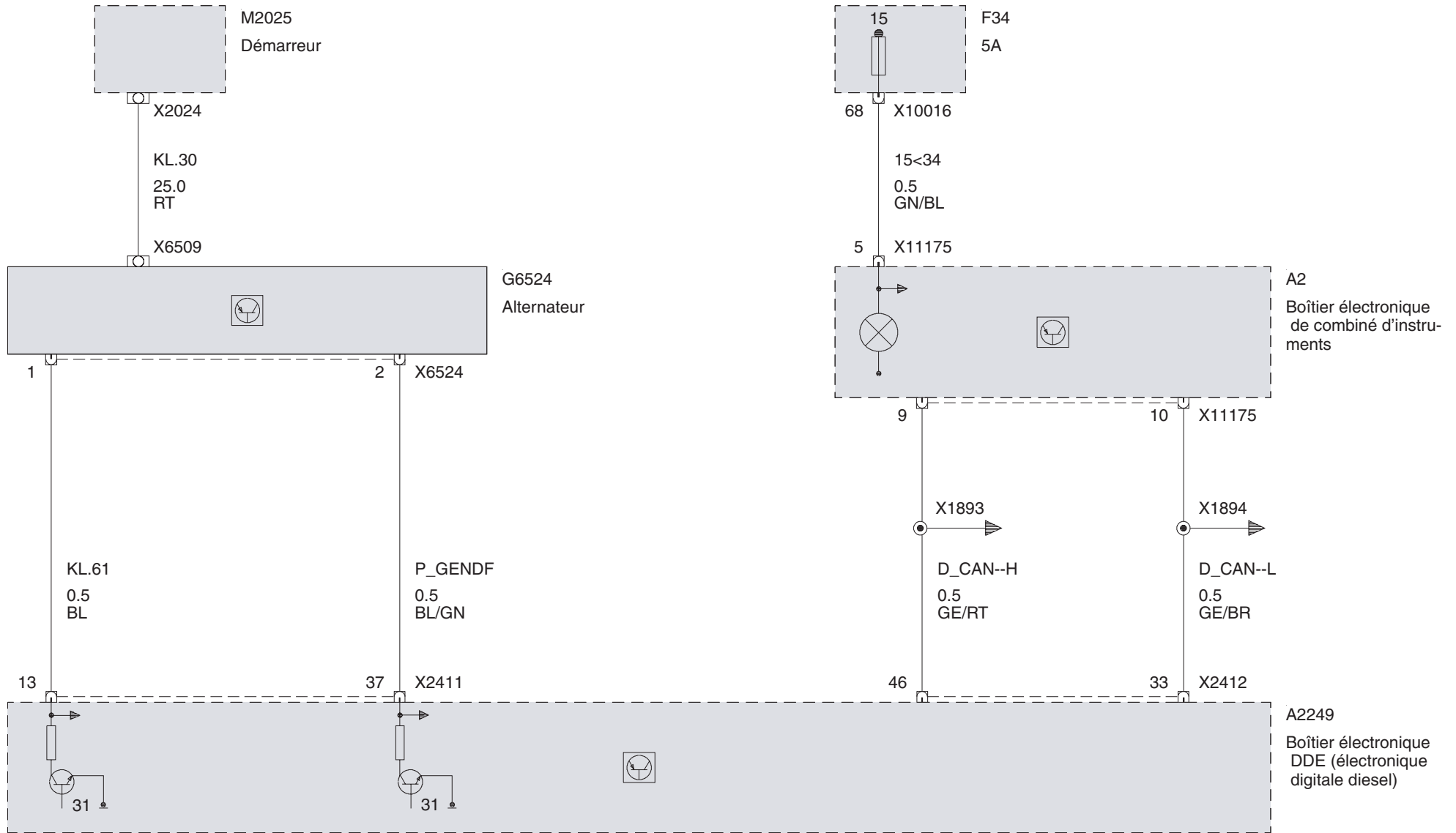

Répartition de l'alimentation batterie

Batterie (Essence avec Batterie dans compartiment à bagages)

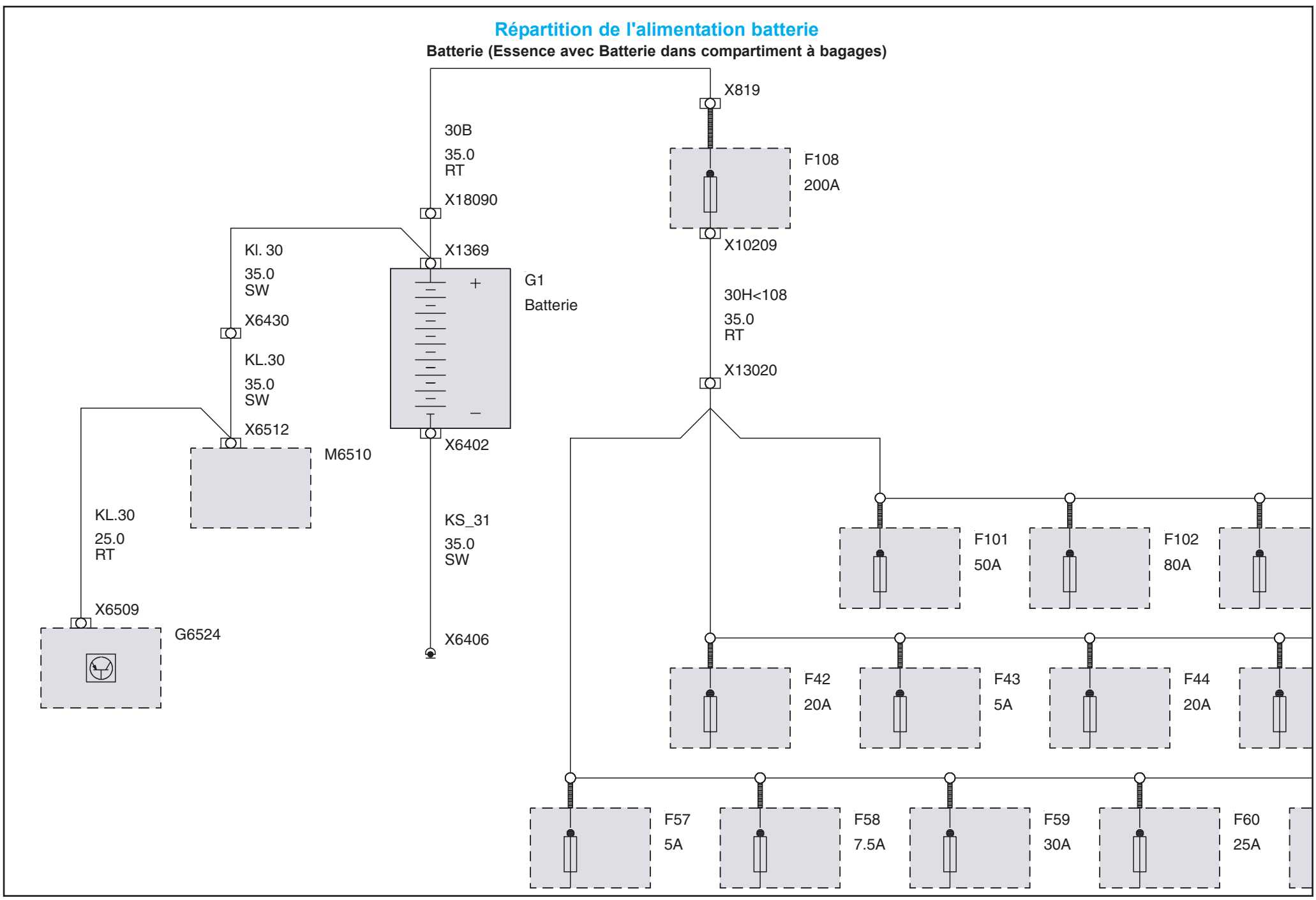

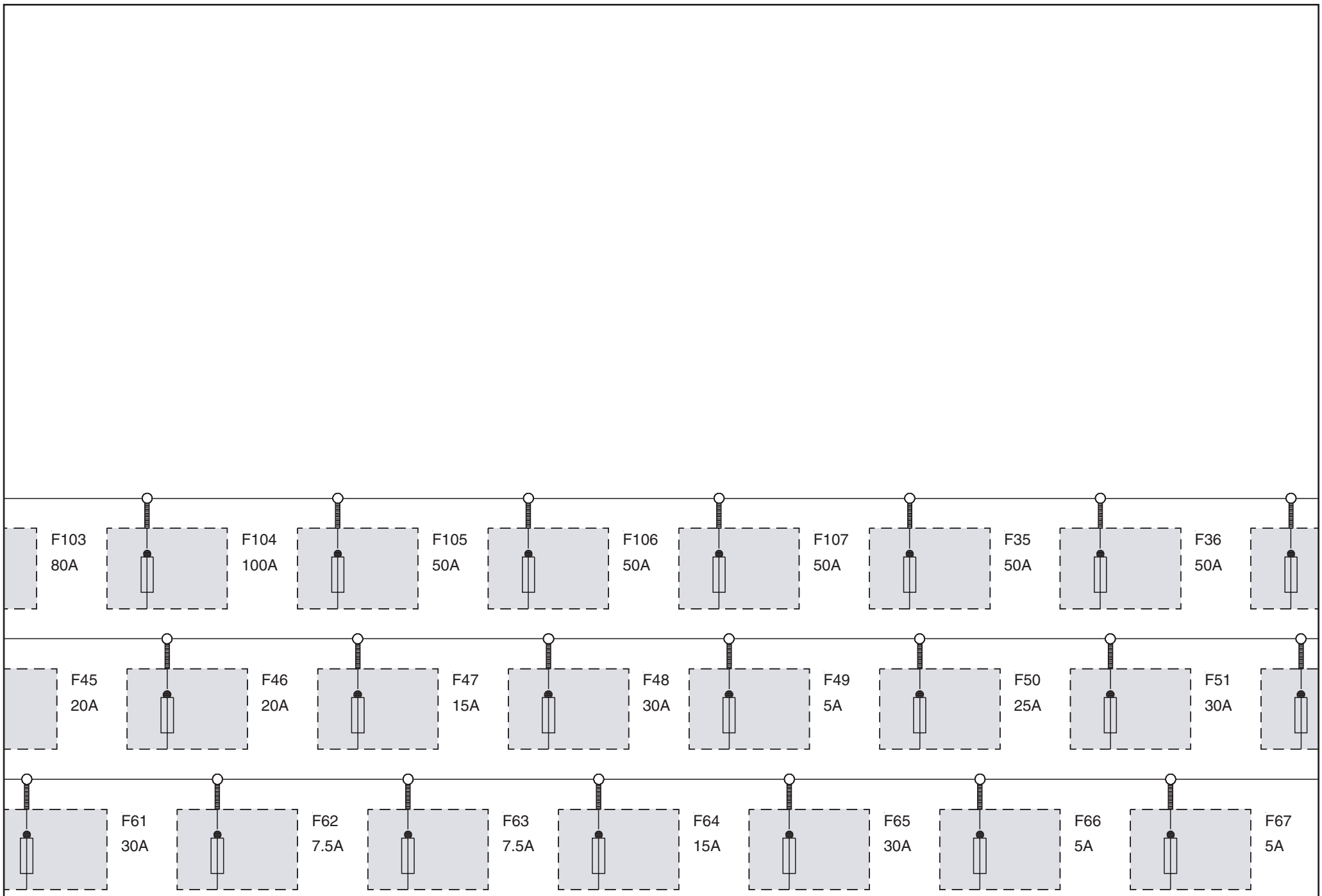

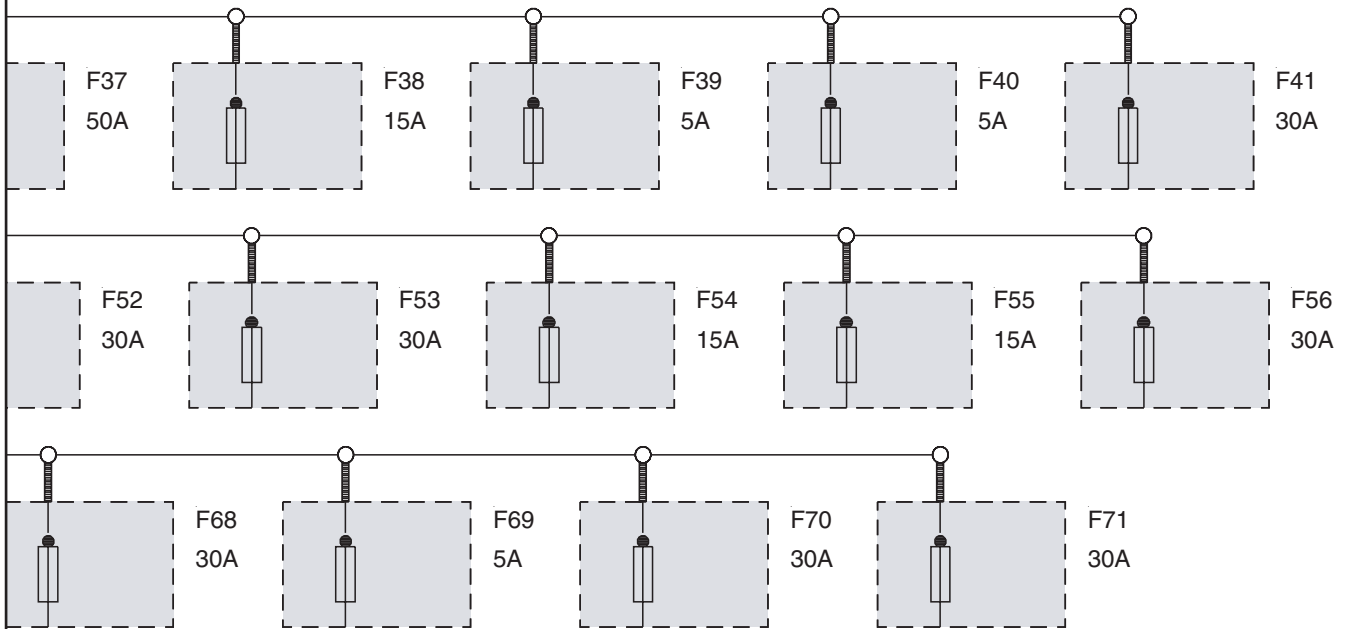

Batterie (Essence sans Batterie dans compartiment à bagages)

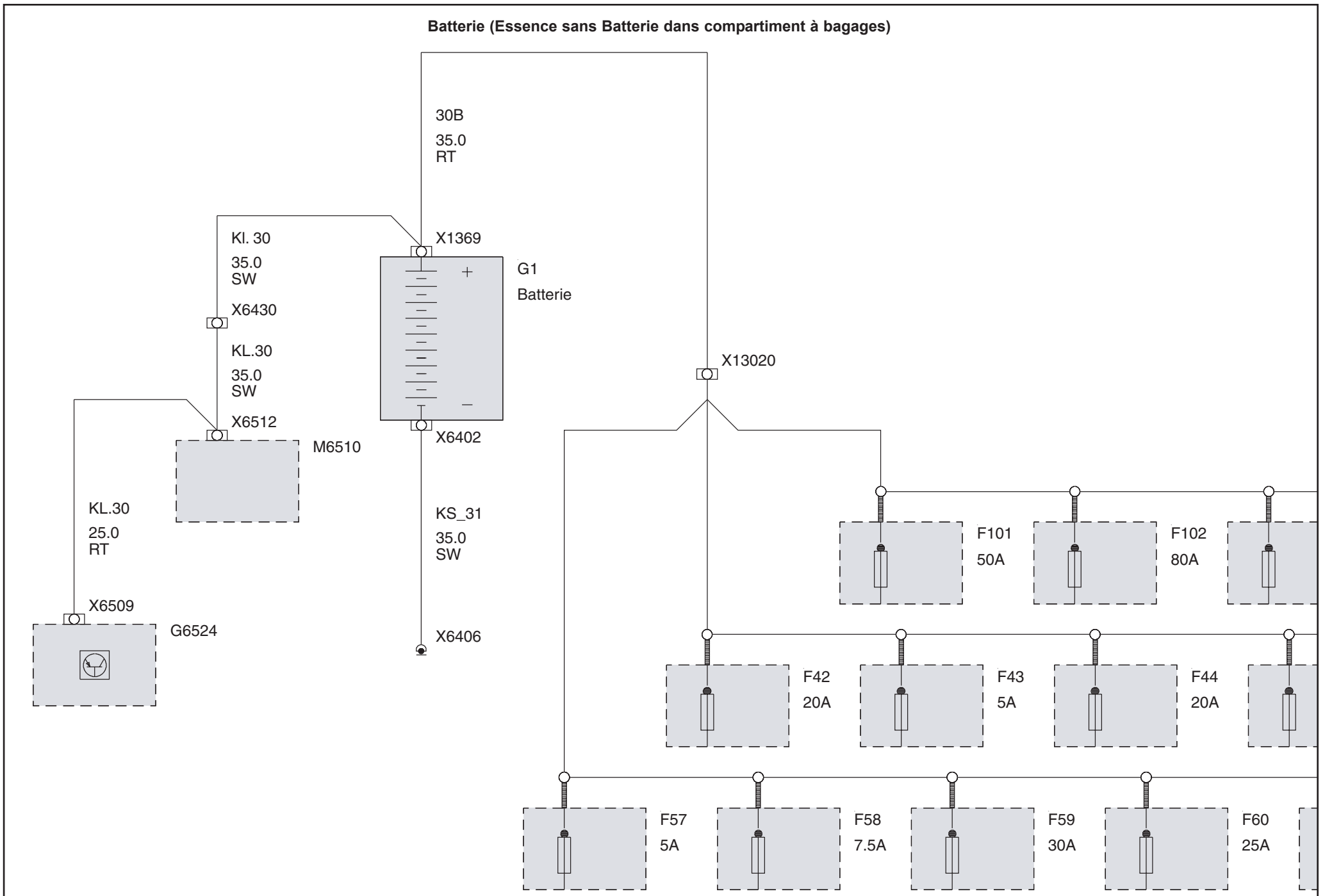

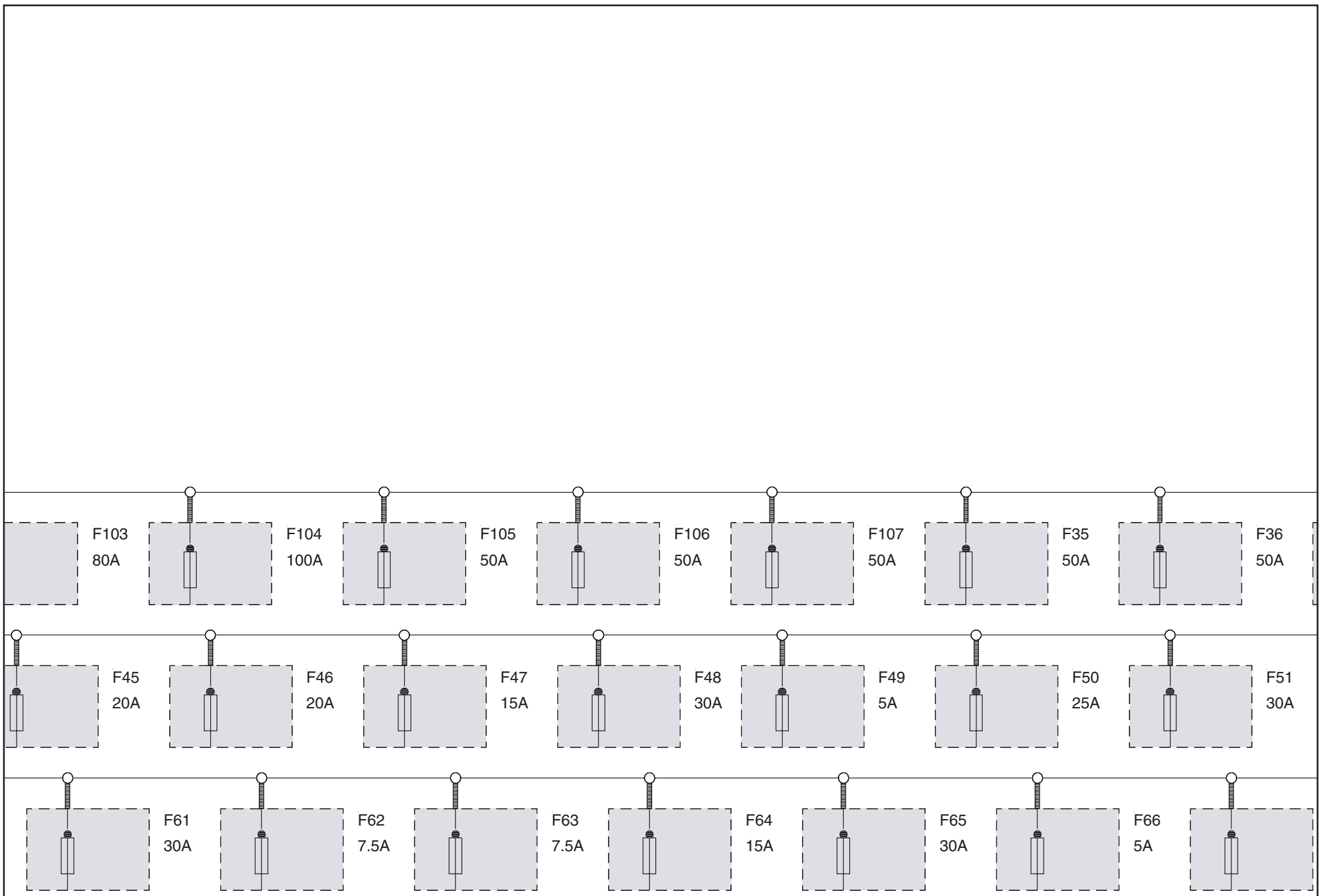

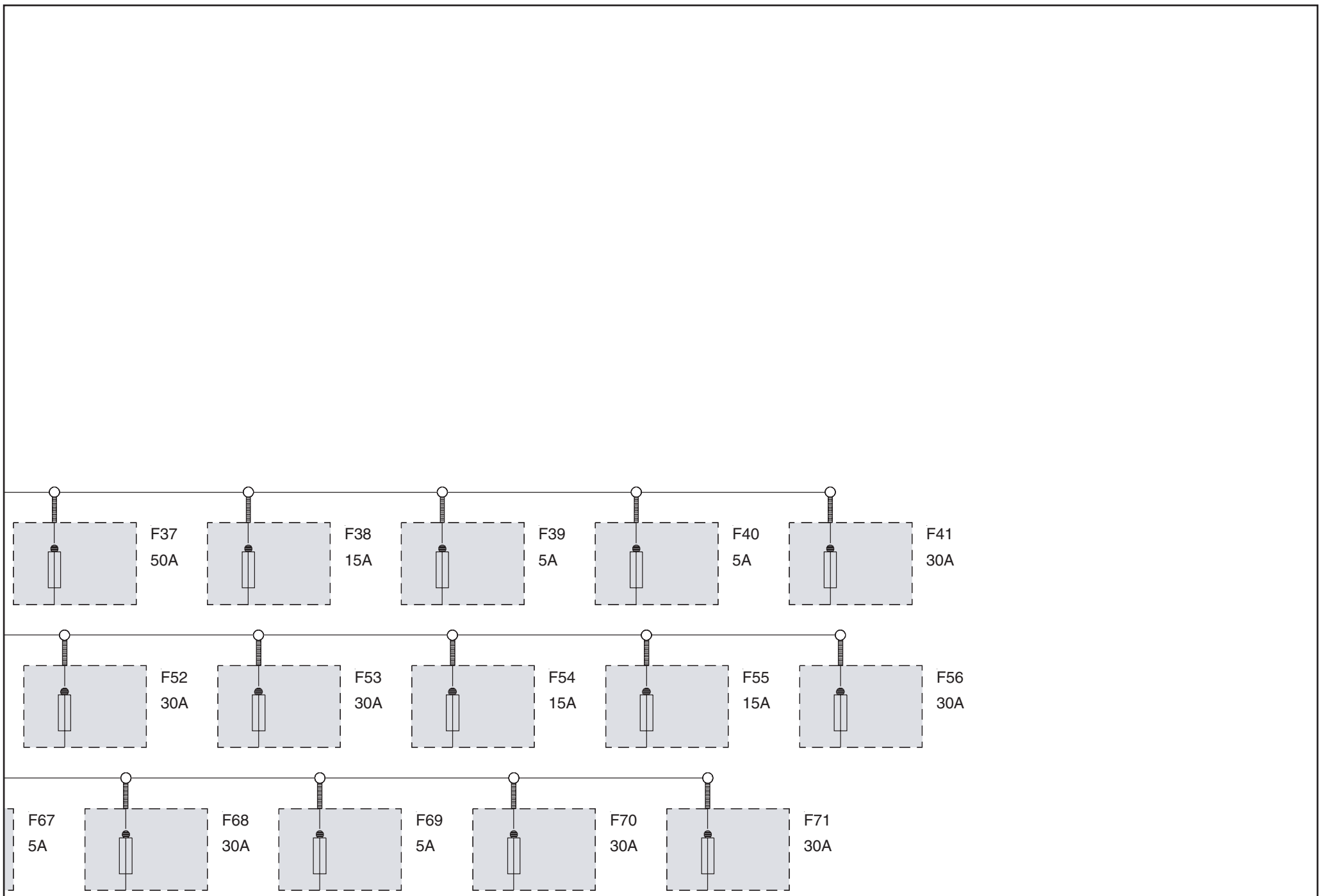

Batterie (Diesel)

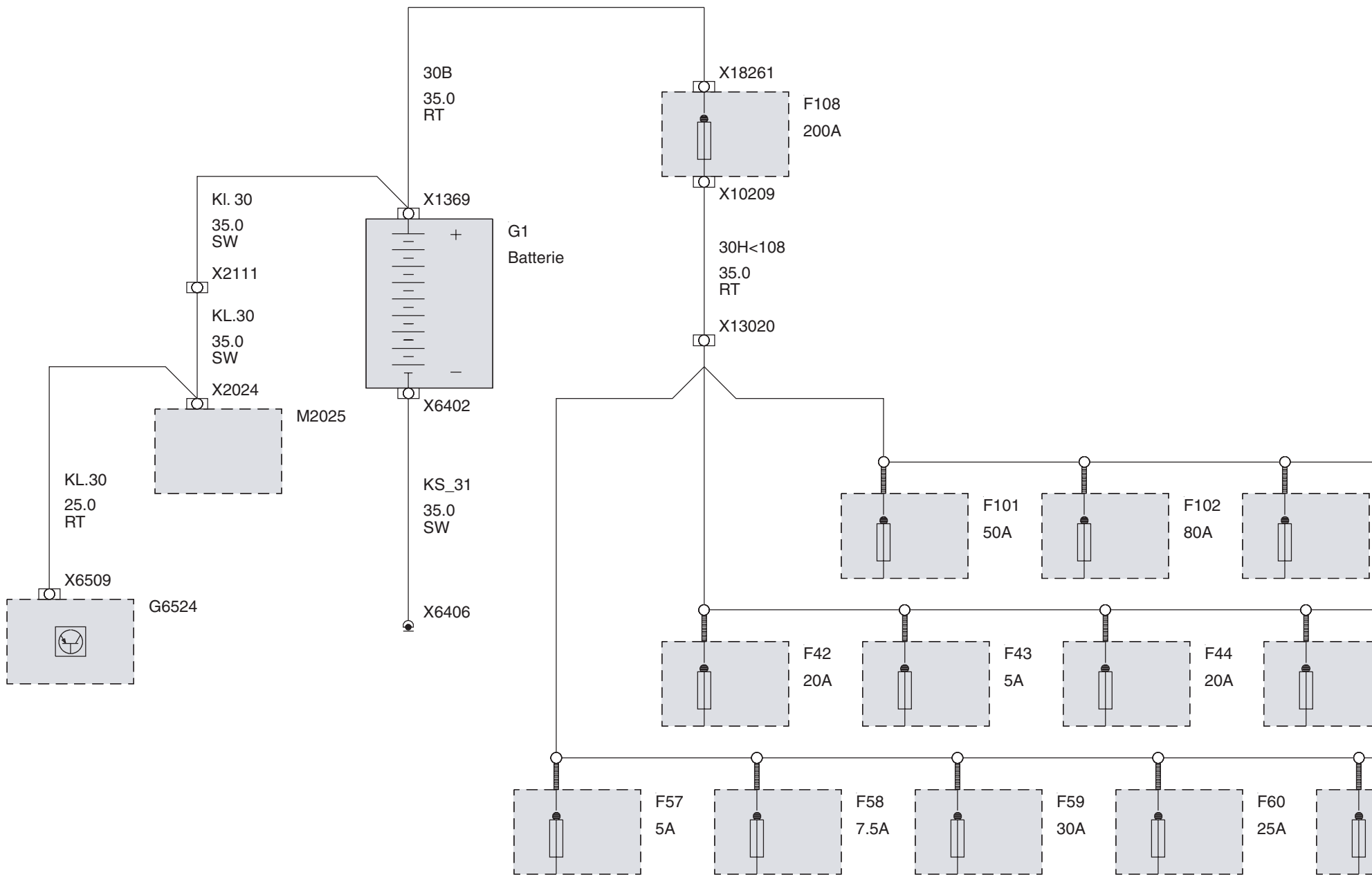



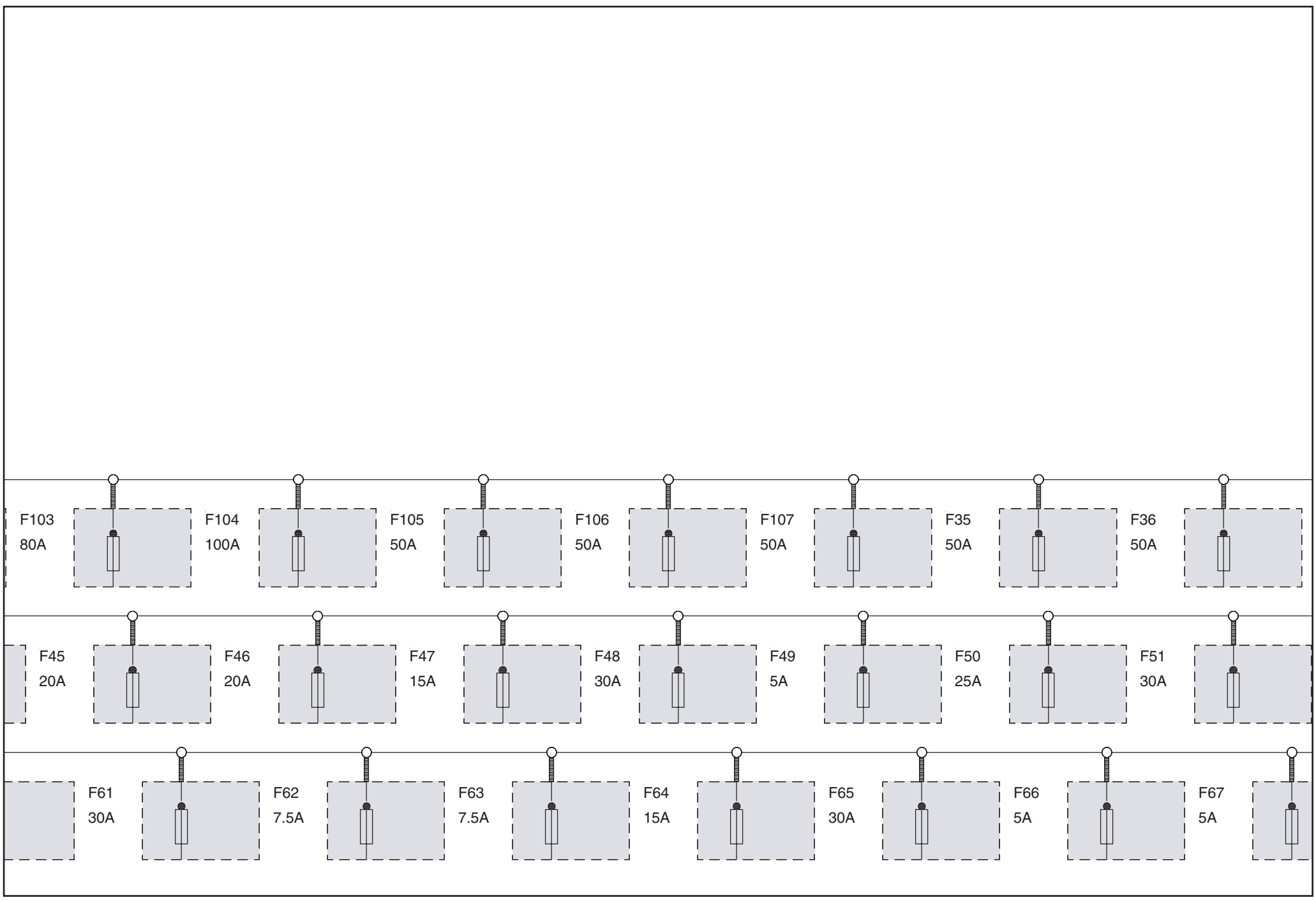

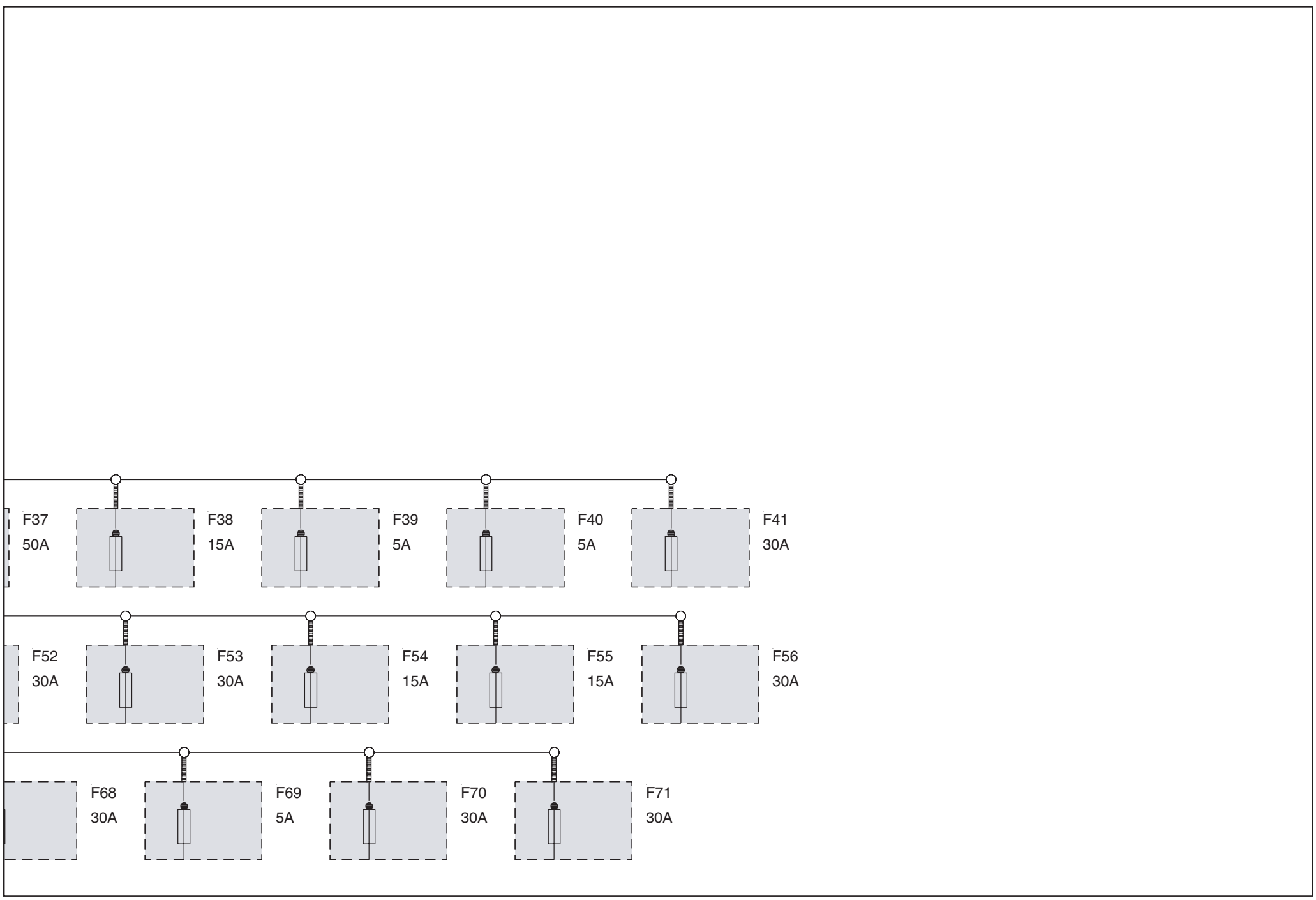

## Démarreur

### Démarreur (DME Electronique moteur MS43)

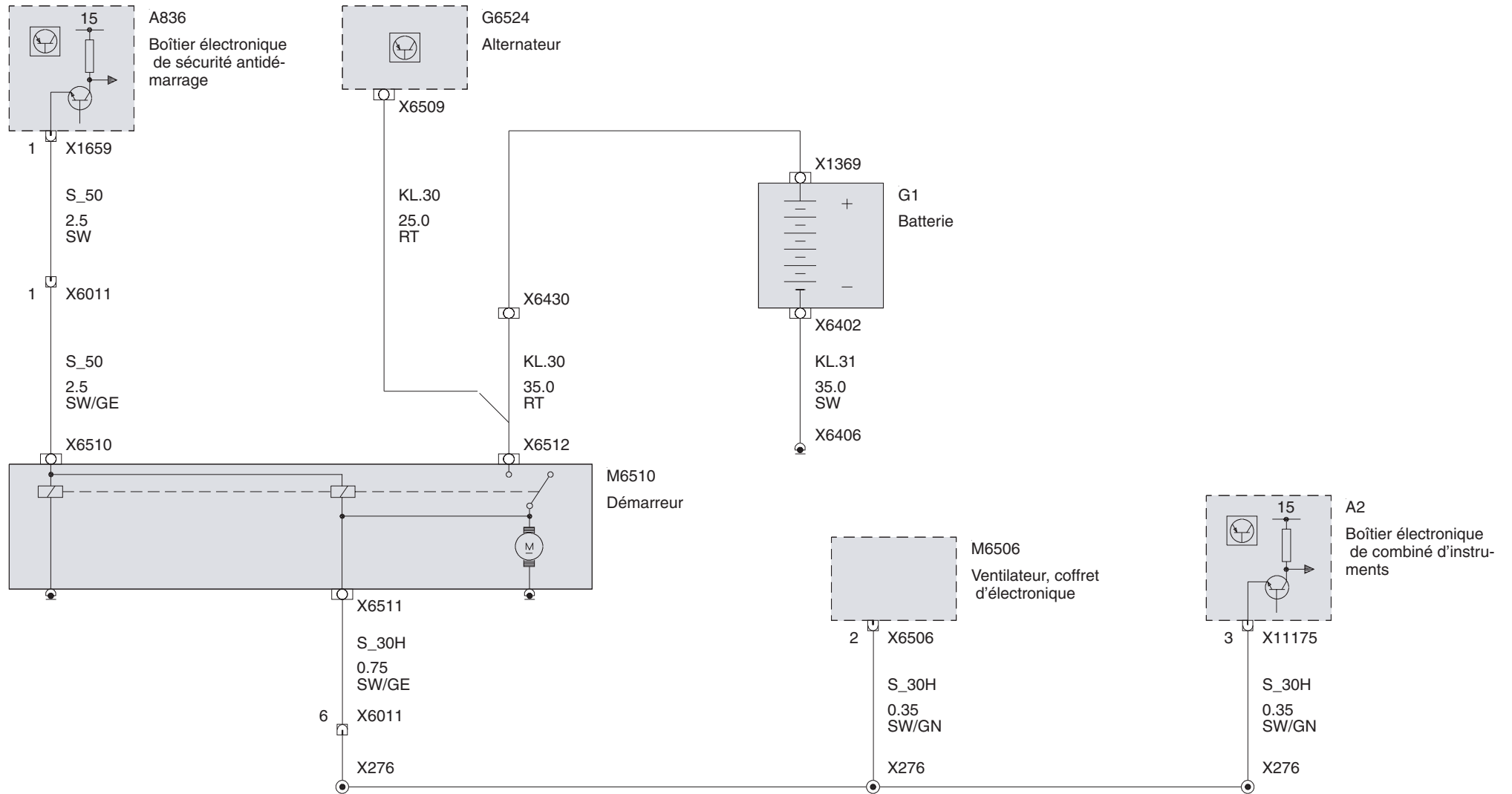

Démarreur (DME Electronique moteur ME9)

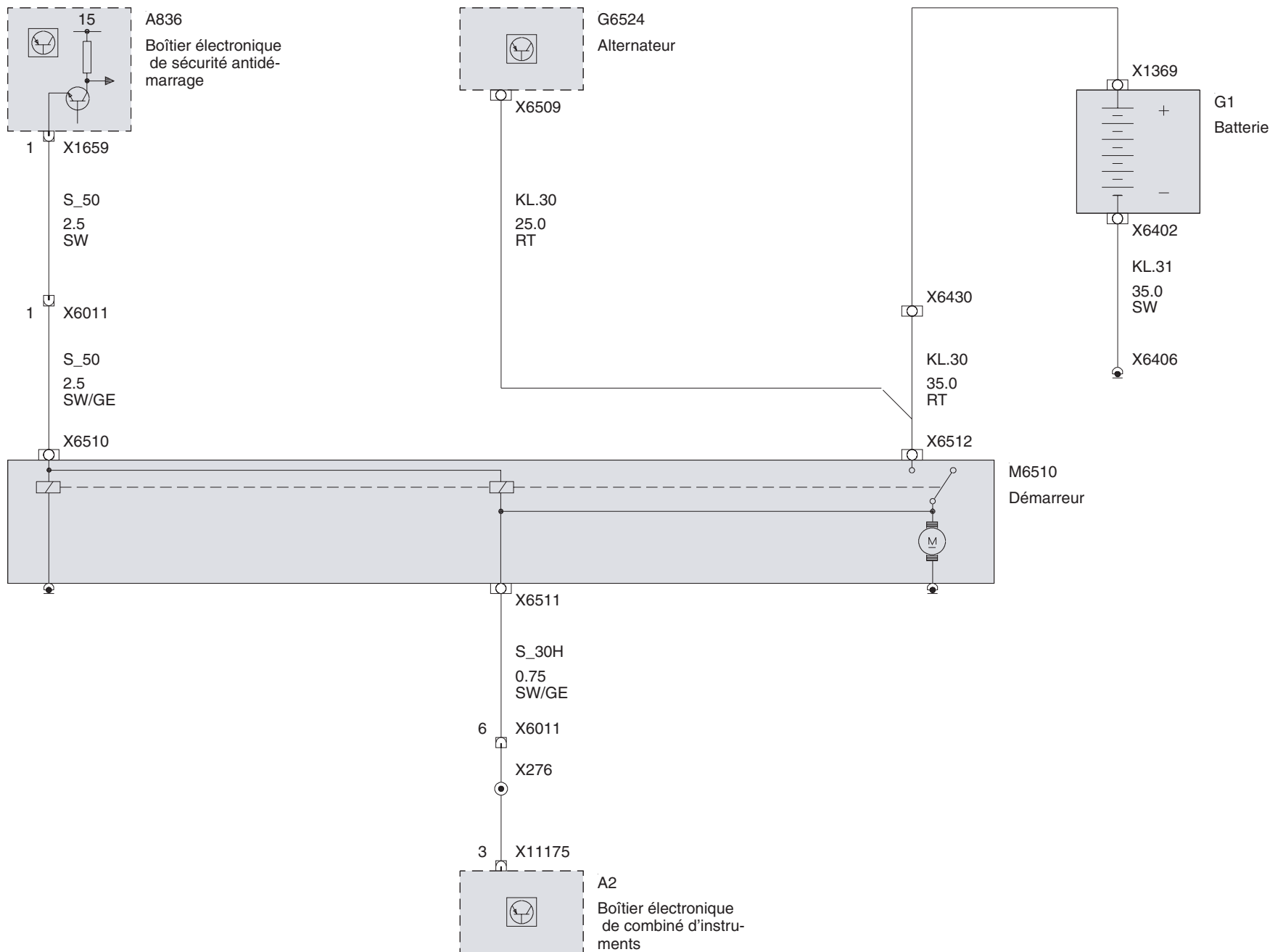

Démarreur (DDE Electronique Diesel DDE50)

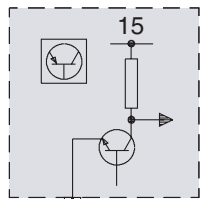

A836  
Boîtier électronique  
de sécurité antidé-  
marrage



G6524  
Alternateur

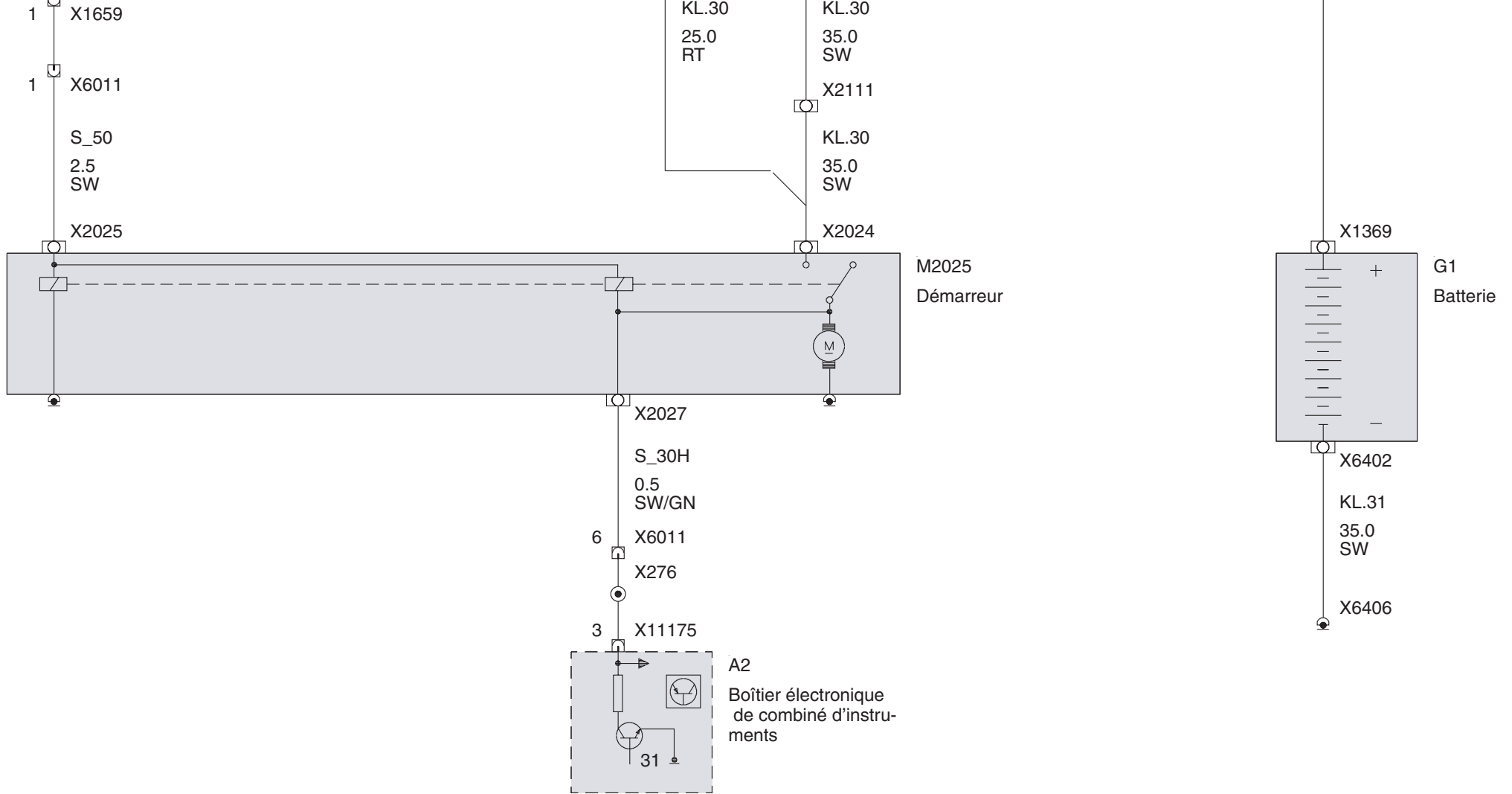

## Système de freinage DSC MK20 (Contrôle dynamique de stabilité)

### Contrôle dynamique de stabilité (DSC)

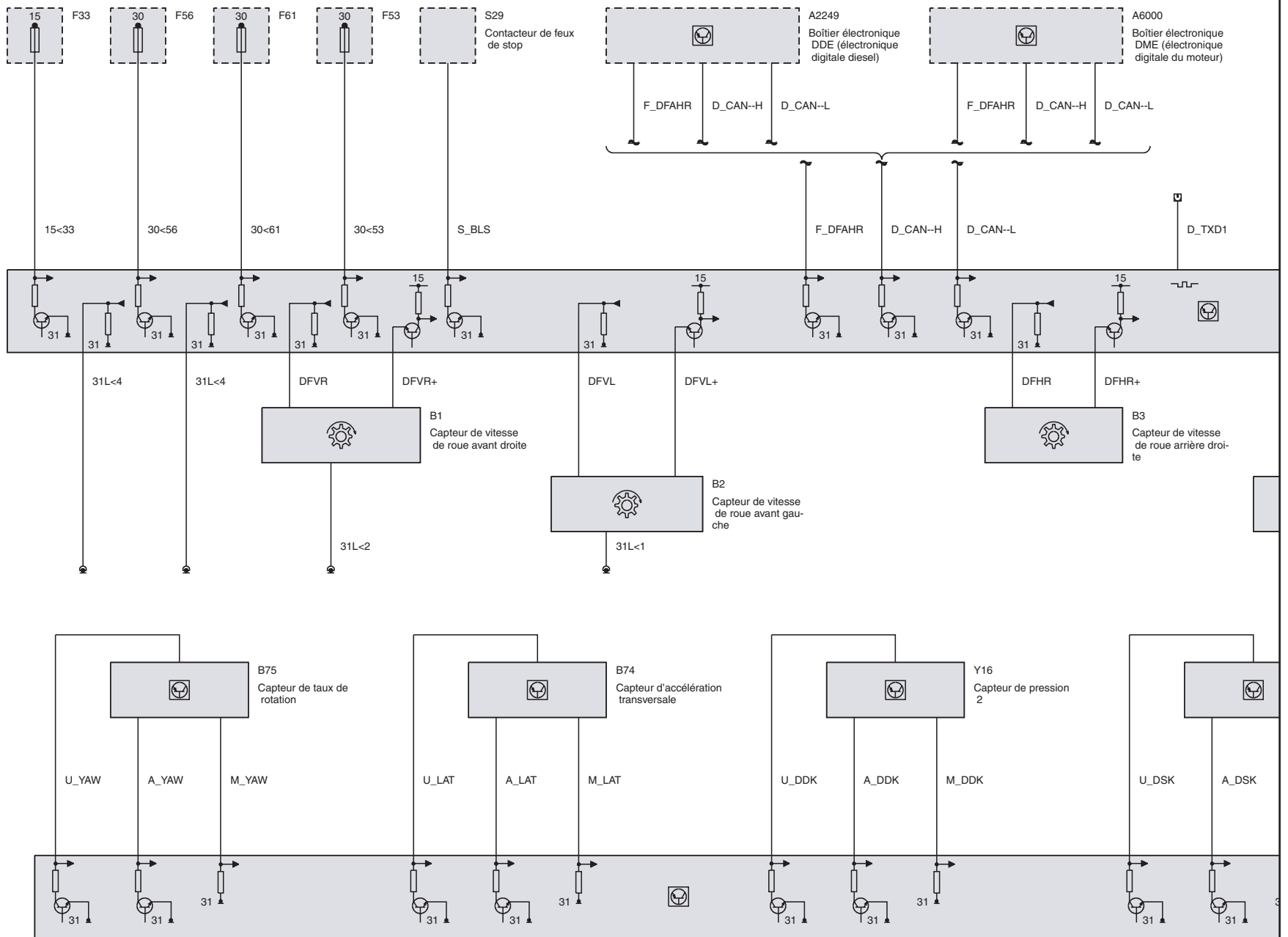

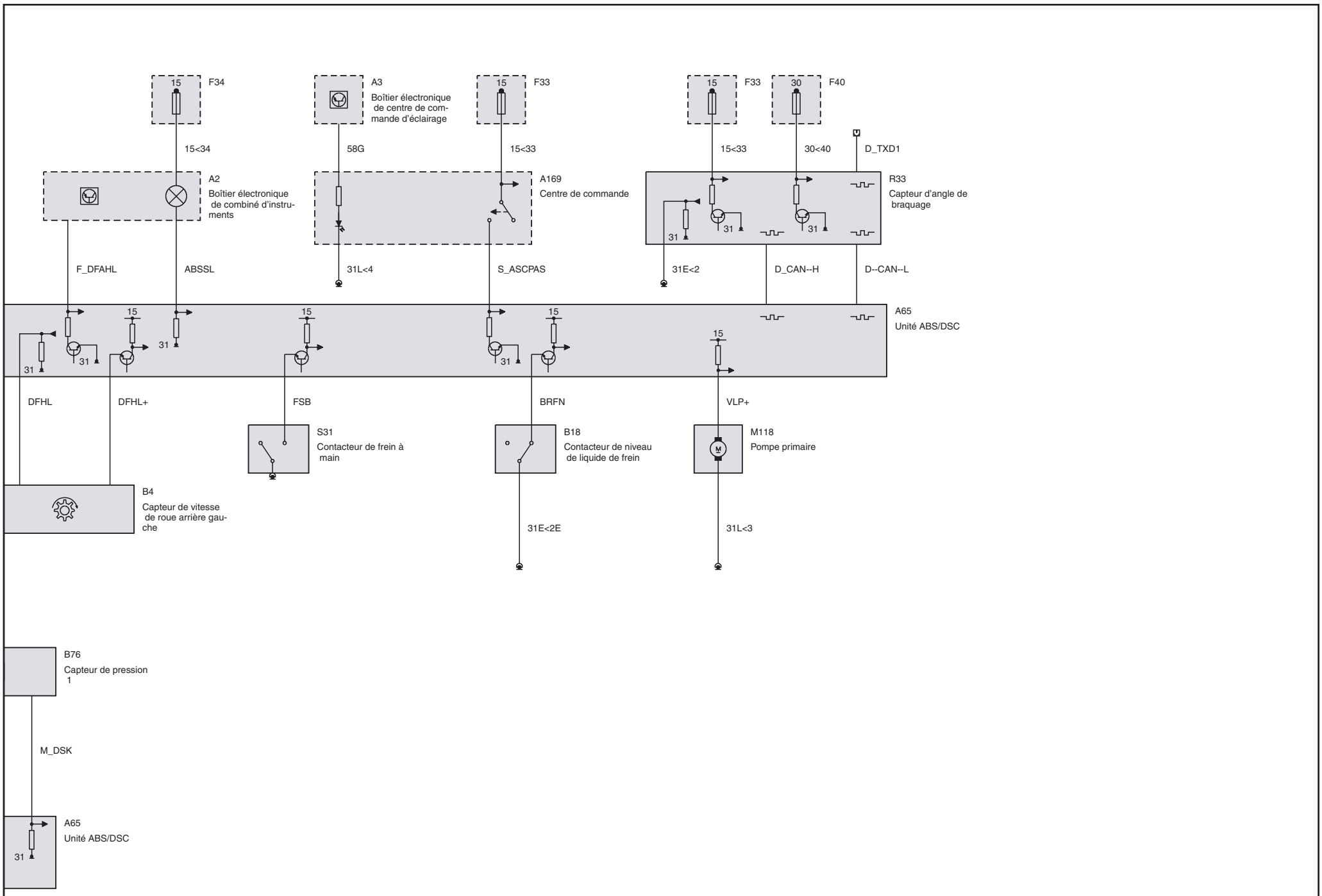

Alimentation

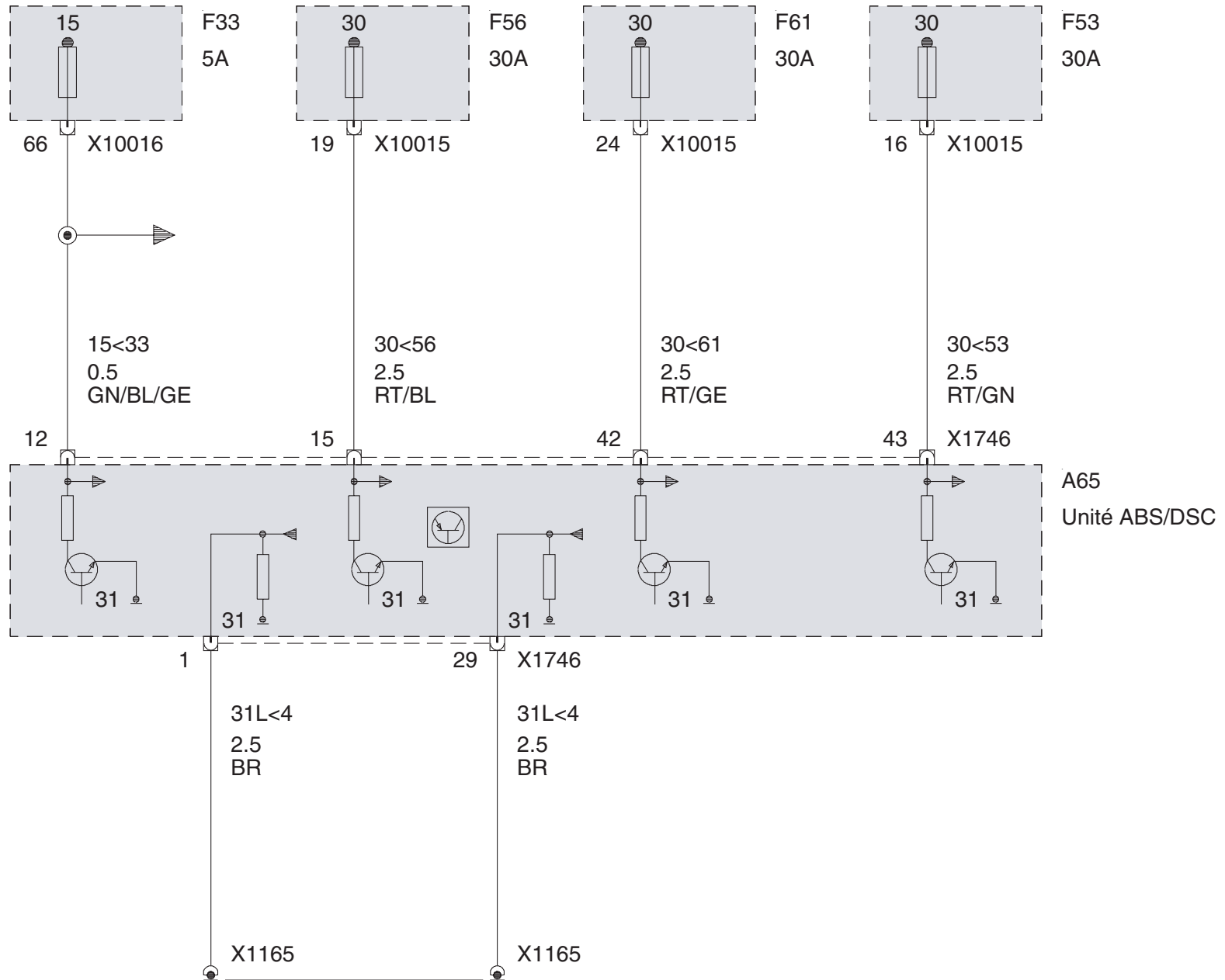



Voyant d'avertissement ABS/DSC

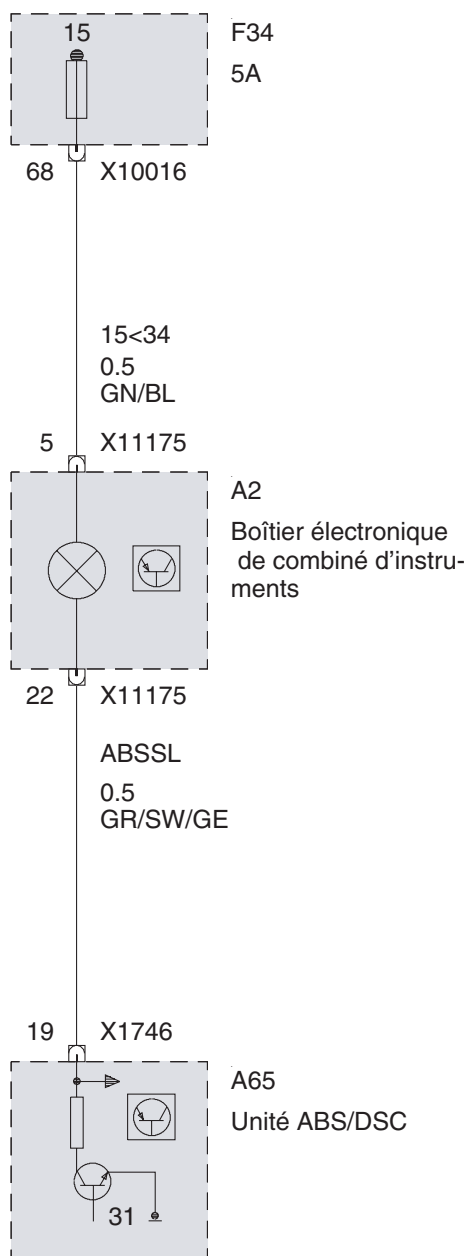

Touche DSC

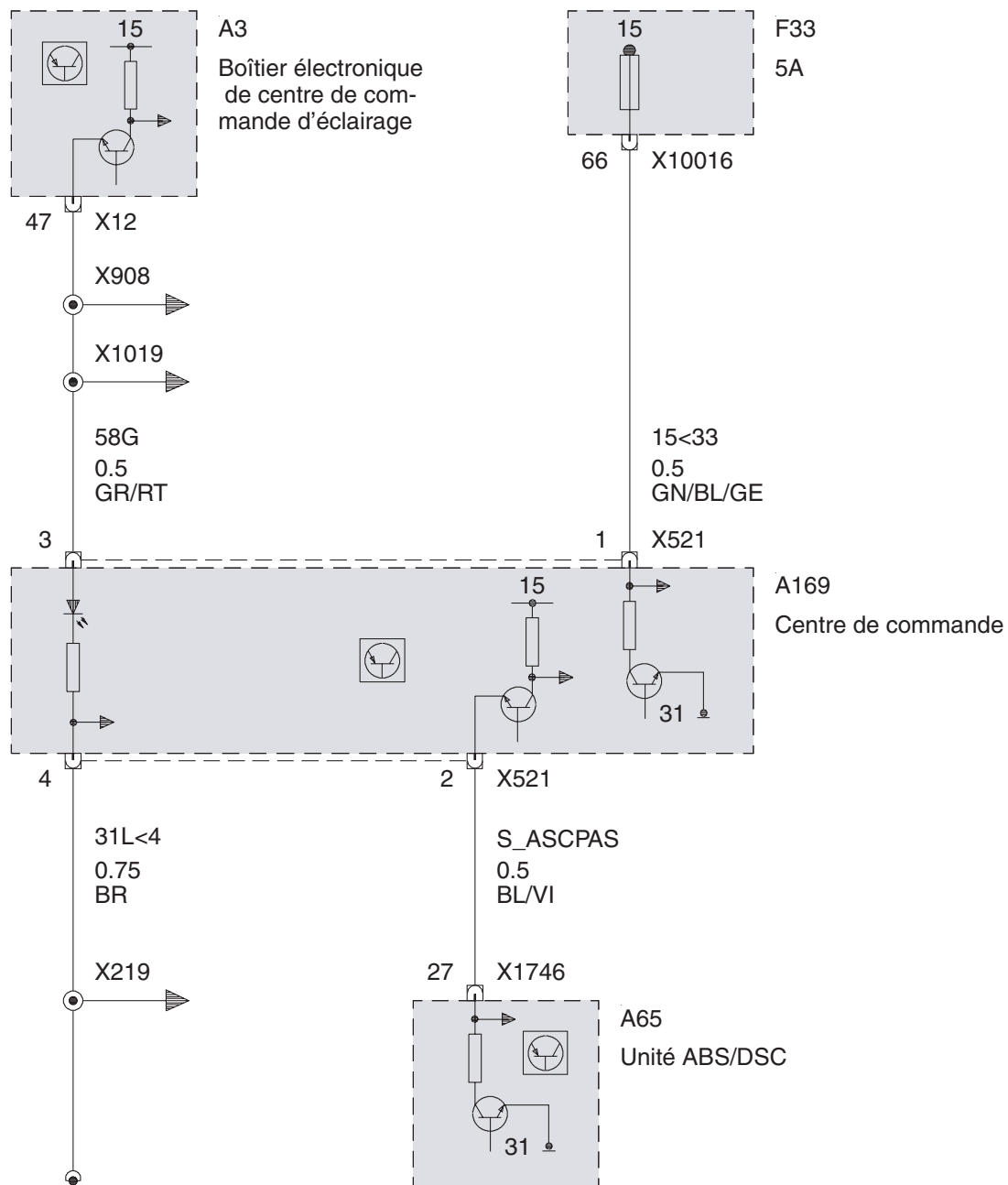

## Contacteur de feux stop (Essence)

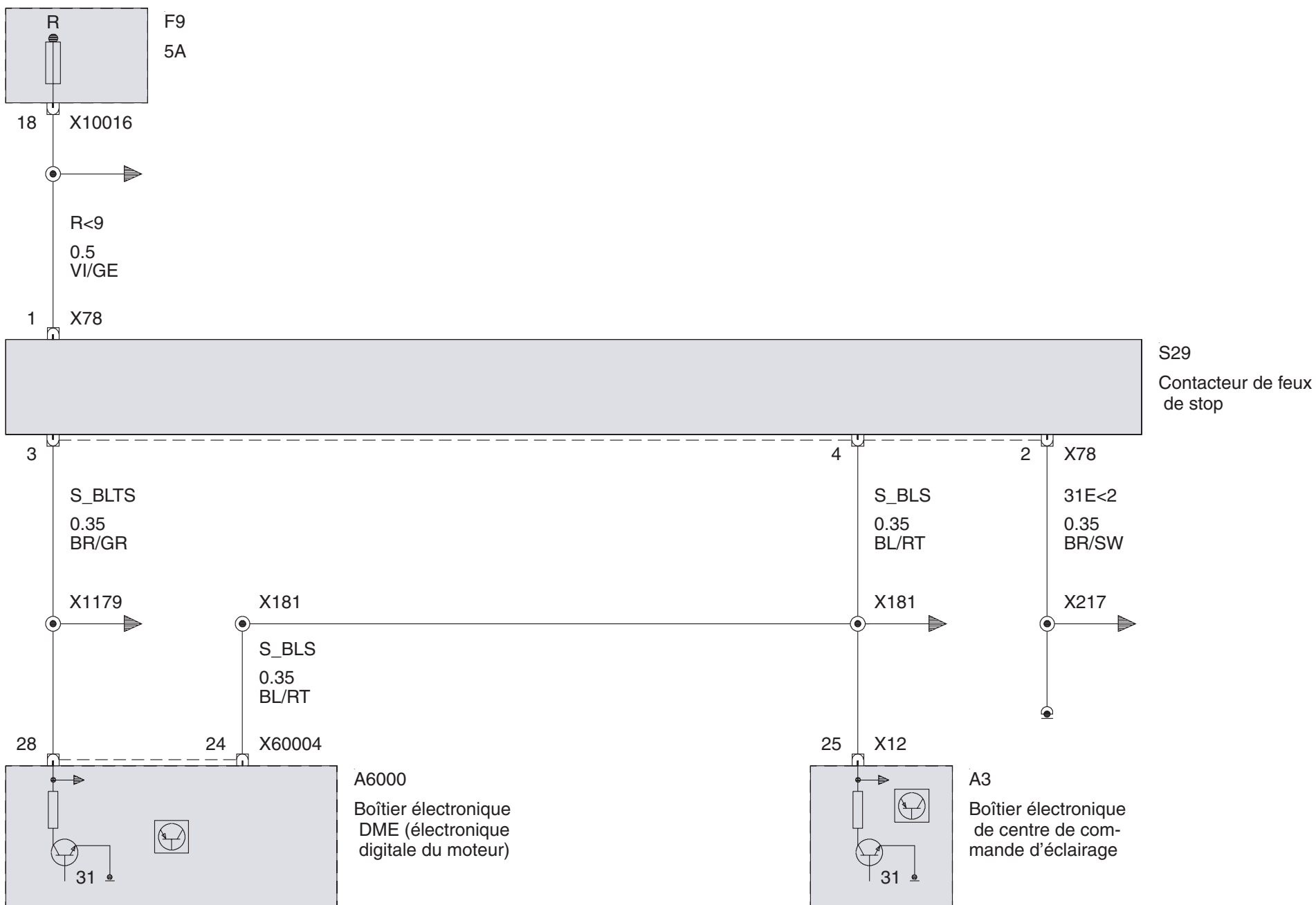

Contacteur de frein à main

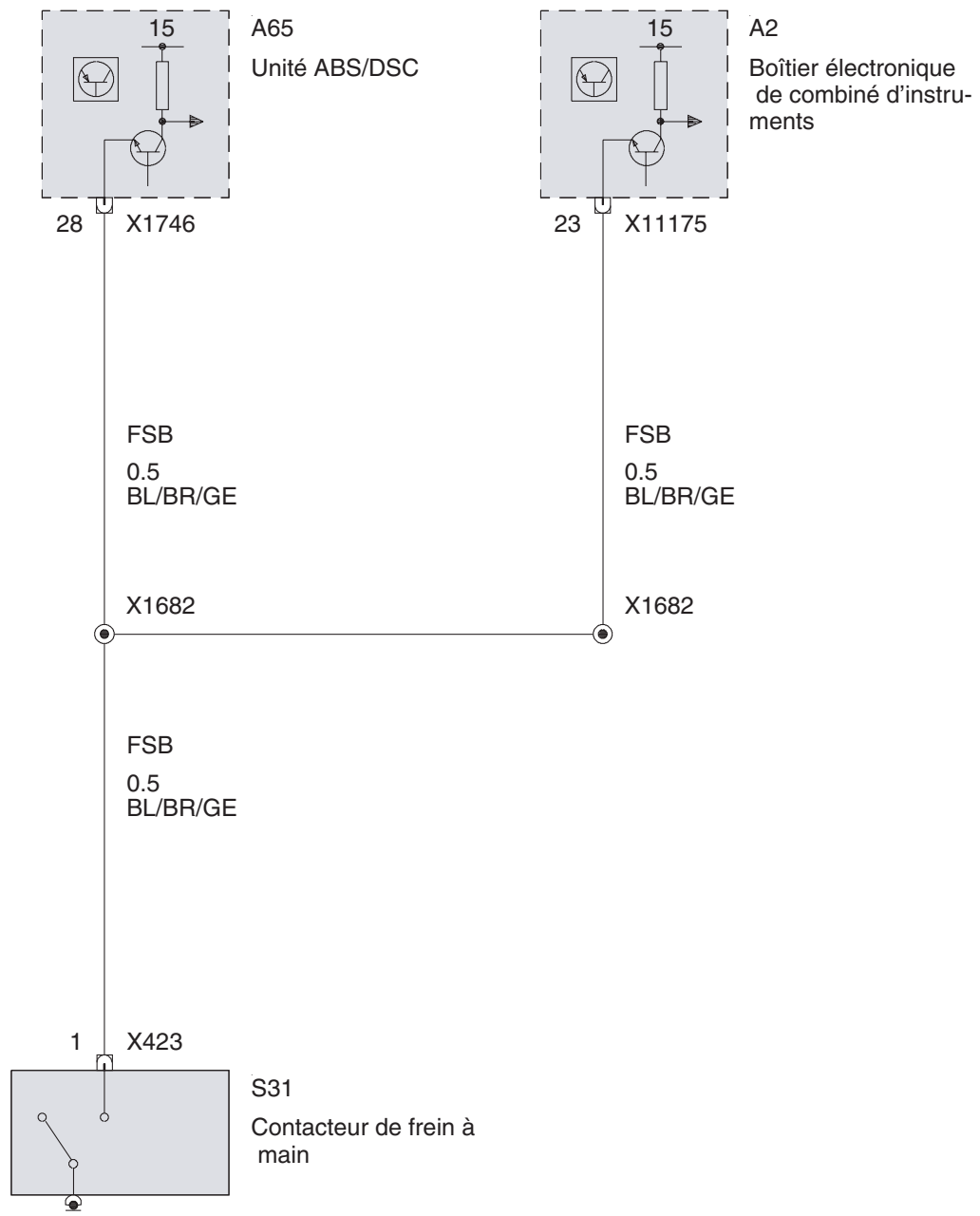

Capteur de taux de dérive

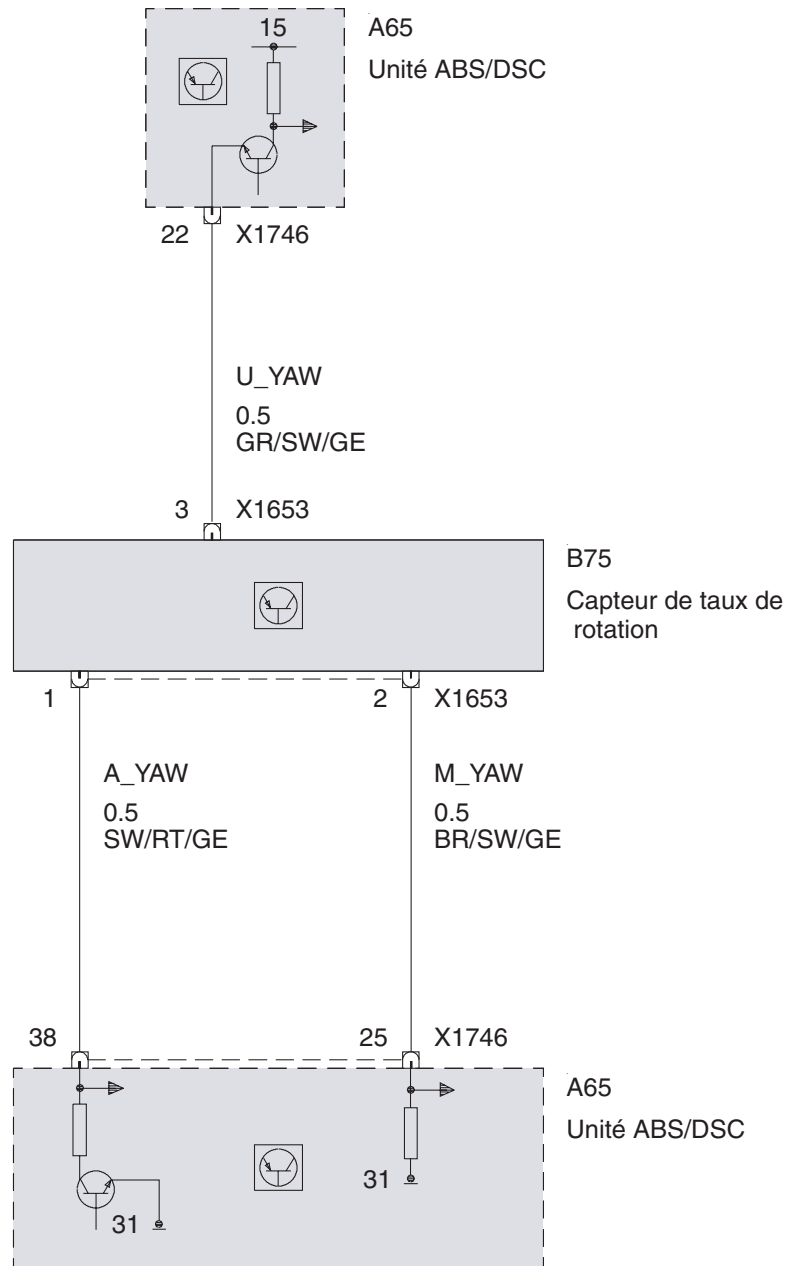

Capteur de vitesse de roue avant

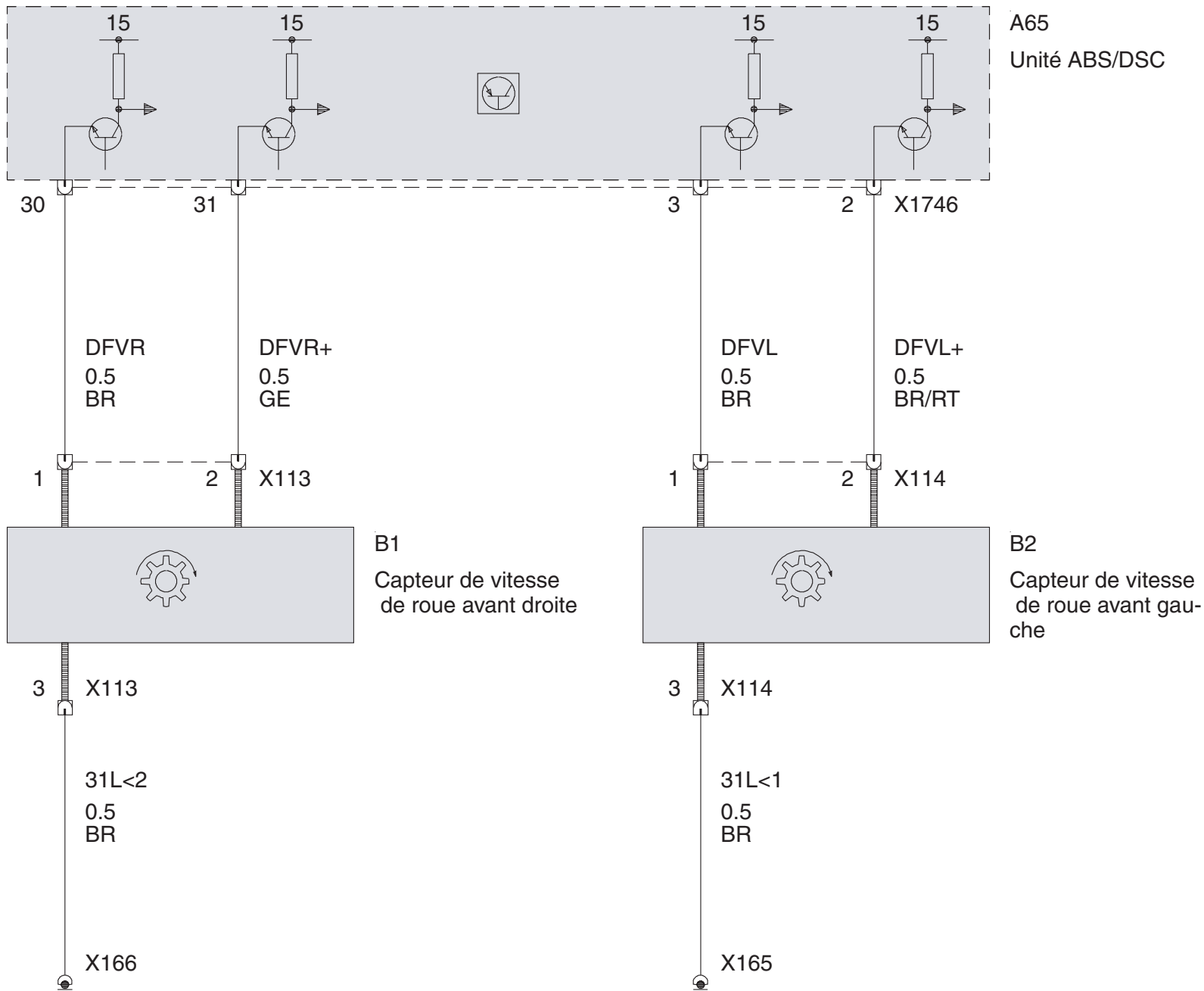

Capteur de vitesse de roue arrière

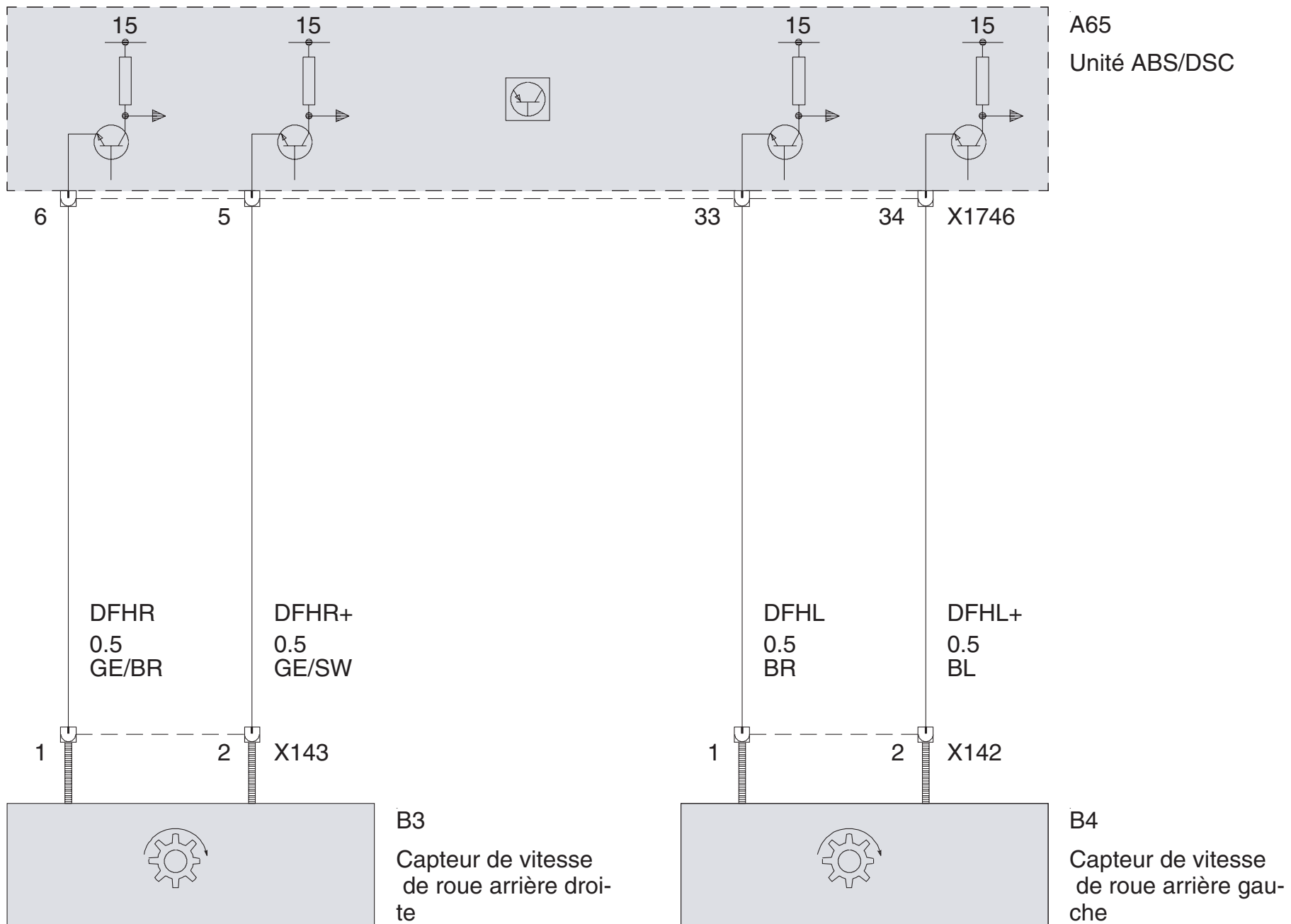

Capteur d'accélération transversale

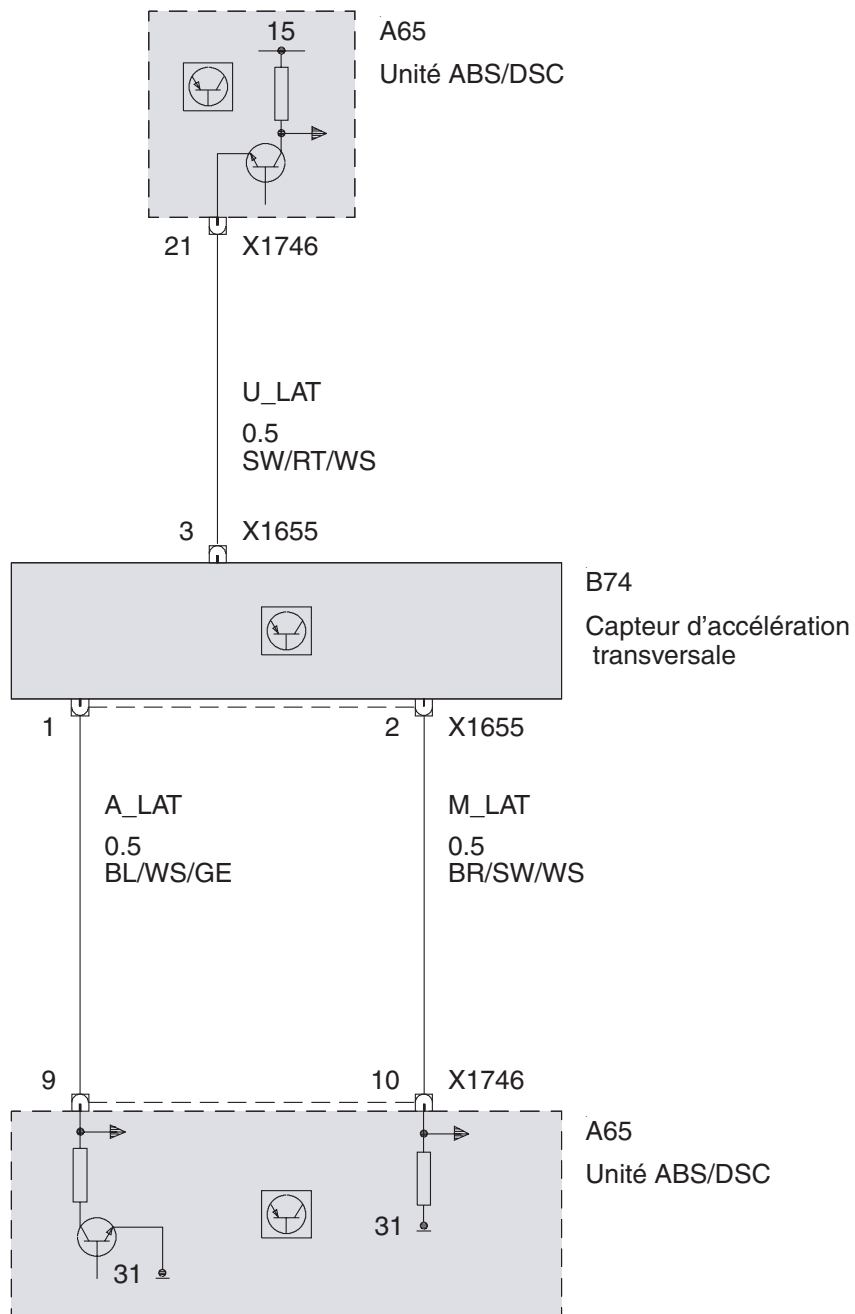



Capteur de pression 1

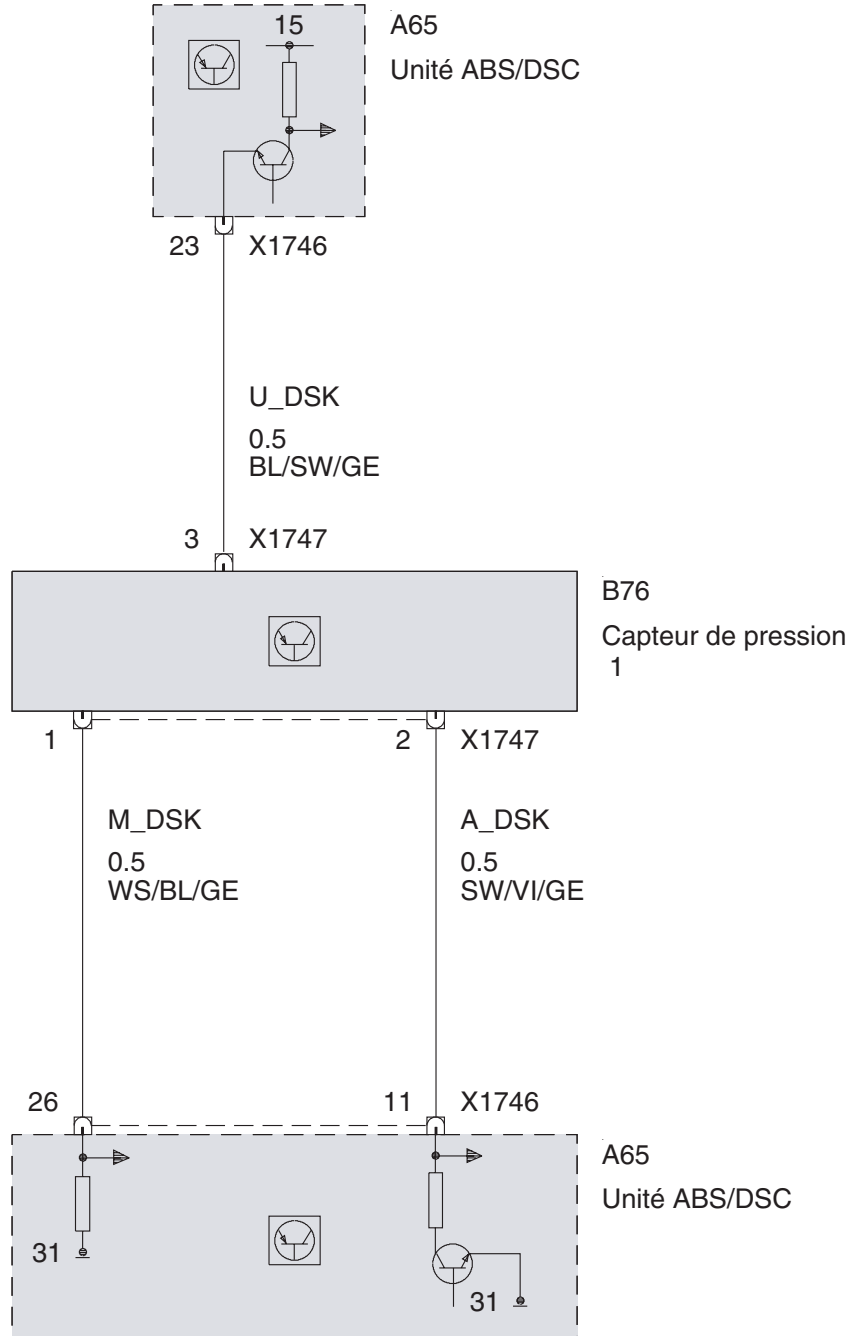

Capteur de pression 2

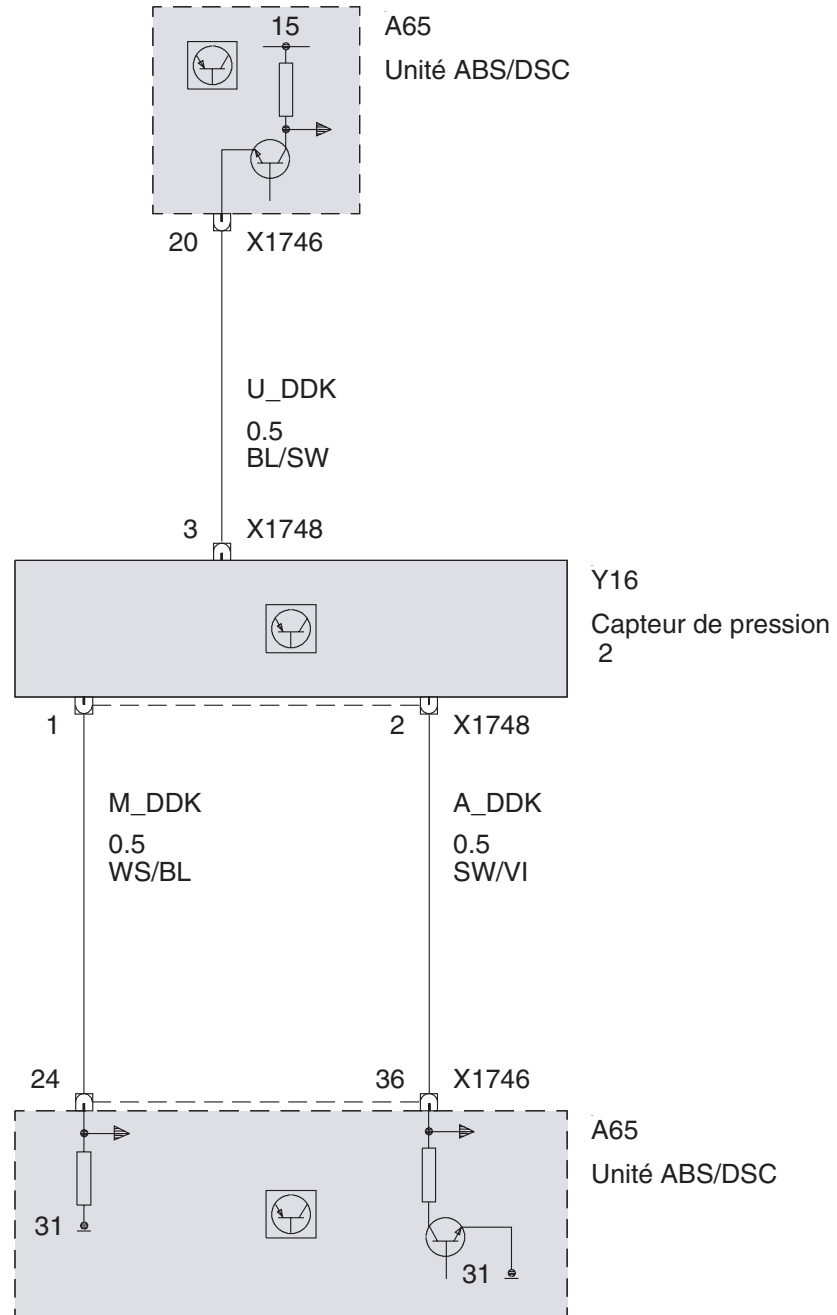

Capteur d'angle de braquage

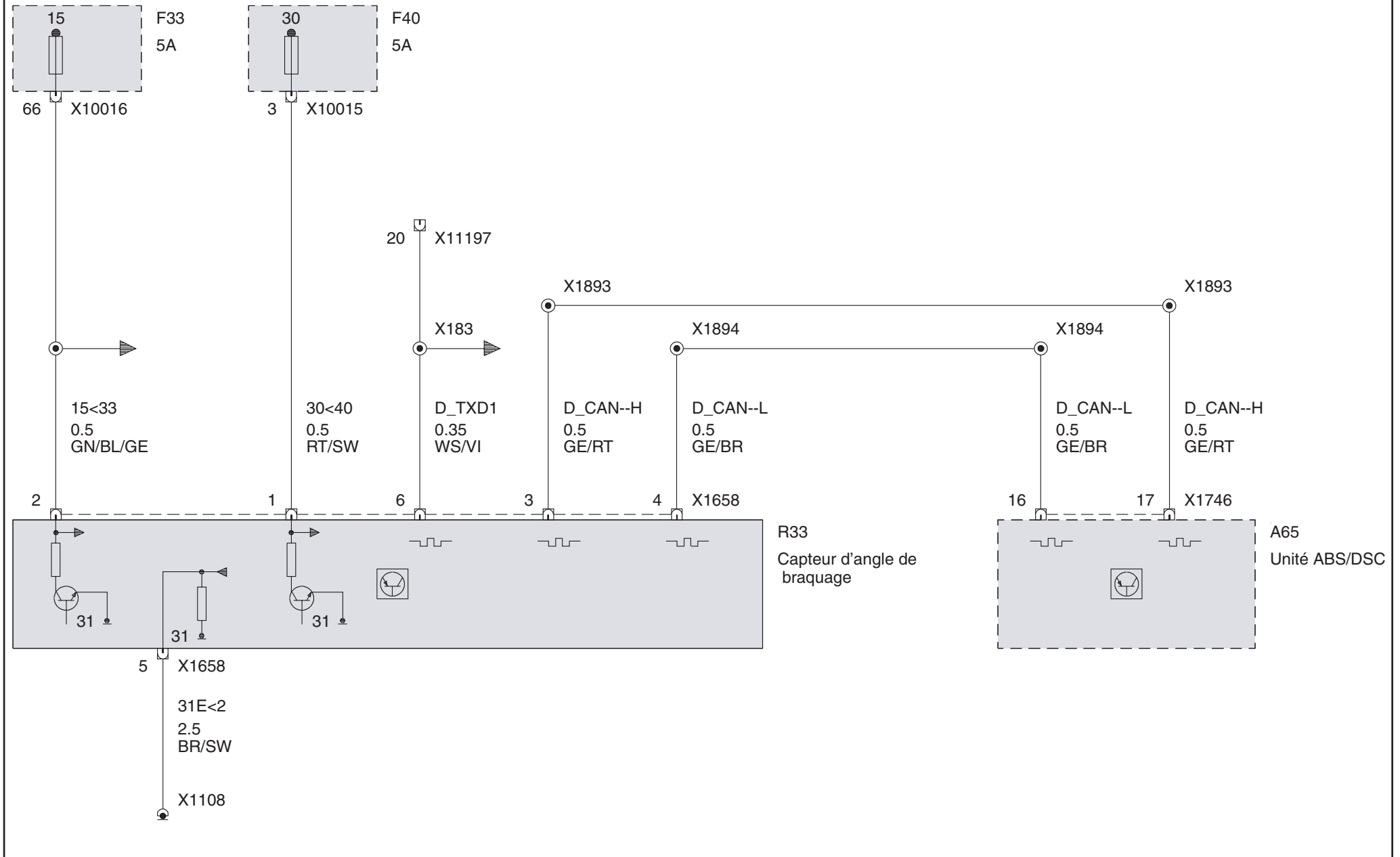

Capteur de niveau liquide de frein

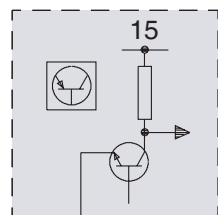

A65  
Unité ABS/DSC

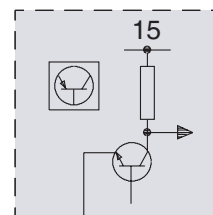

A2  
Boîtier électronique  
de combiné d'instru-  
ments

41 X1746

20 X11175

BRFN  
0.35  
BR/GN/GE

BRFN  
0.35  
BR/GN/GE

X1123

X1123

BRFN  
0.35  
BR/GN/GE

2 X111

B18  
Contacteur de niveau  
de liquide de frein

1 X111

31E<2E  
0.35  
BR/SW

X1108

Pompe de précharge

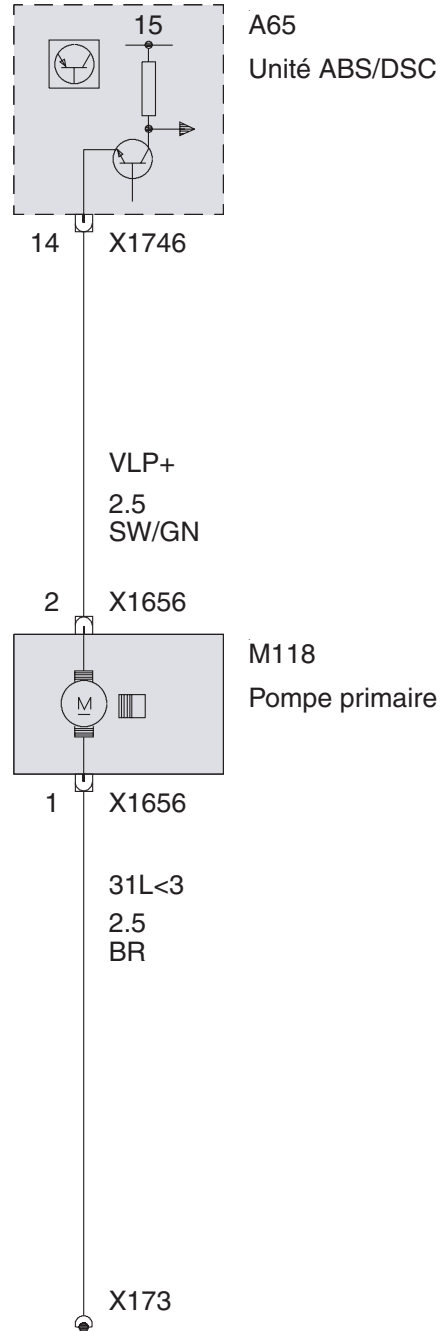

## Système de freinage DSC MK60 (DSC Contrôle dynamique de stabilité) Contrôle dynamique de stabilité (DSC)

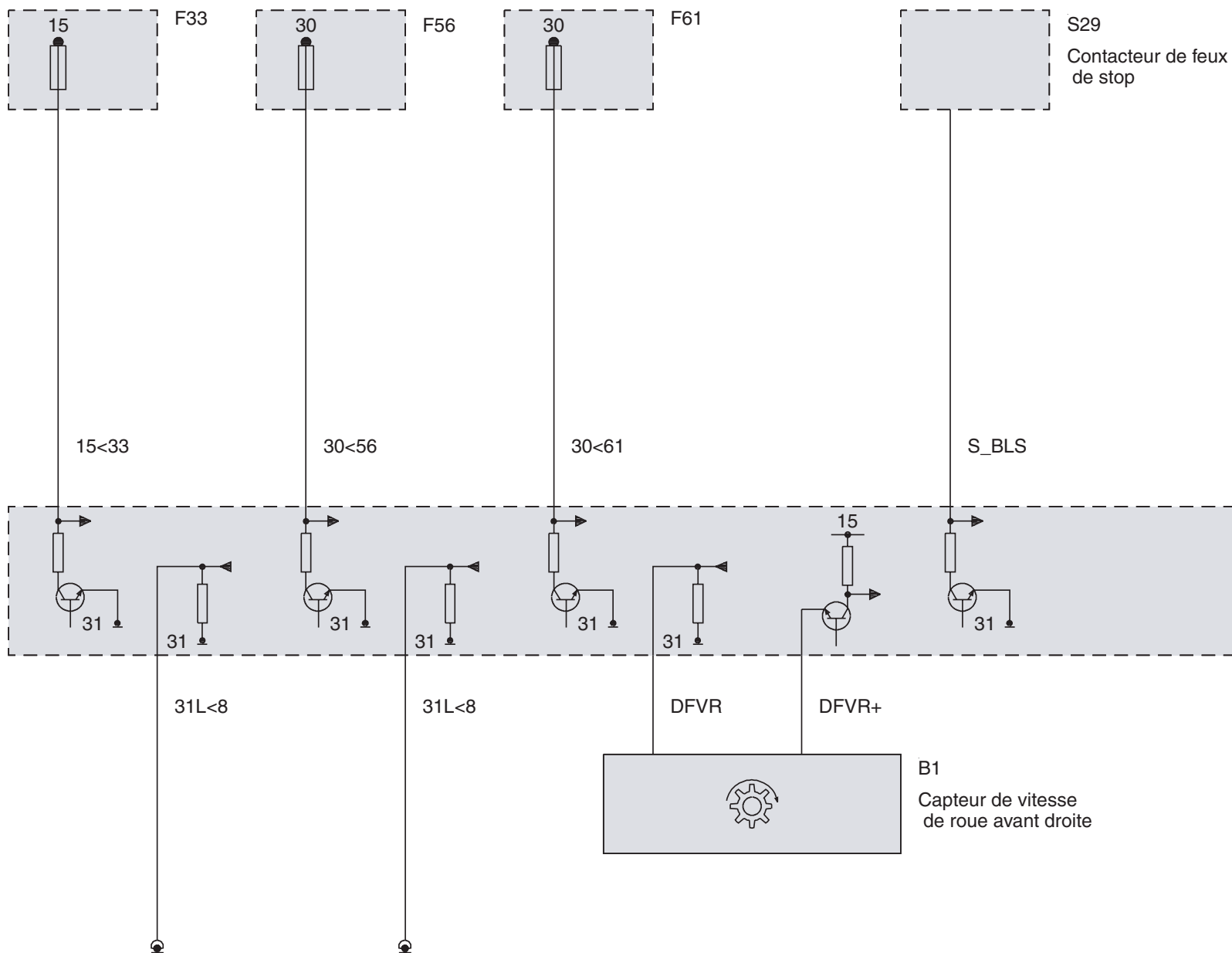

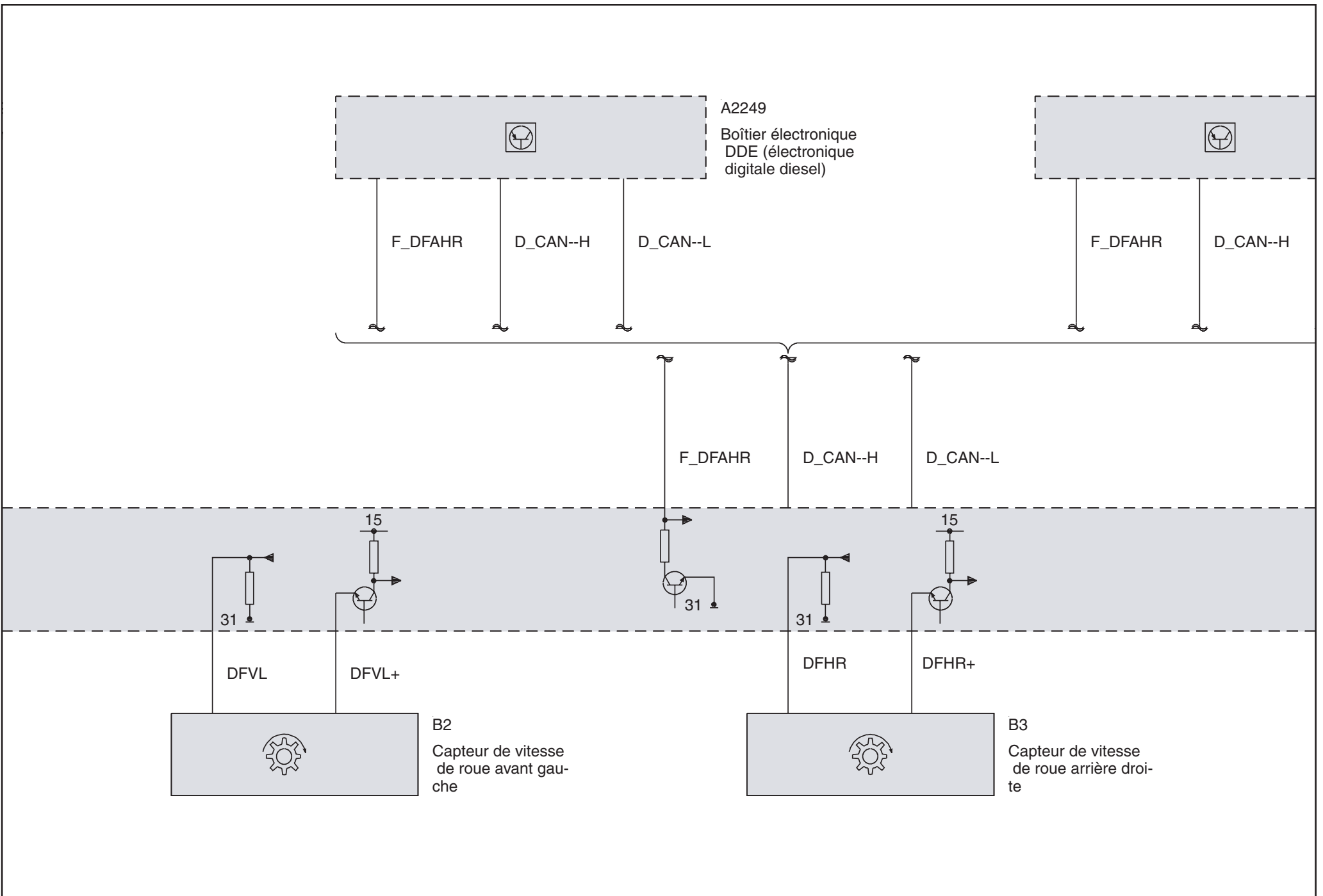

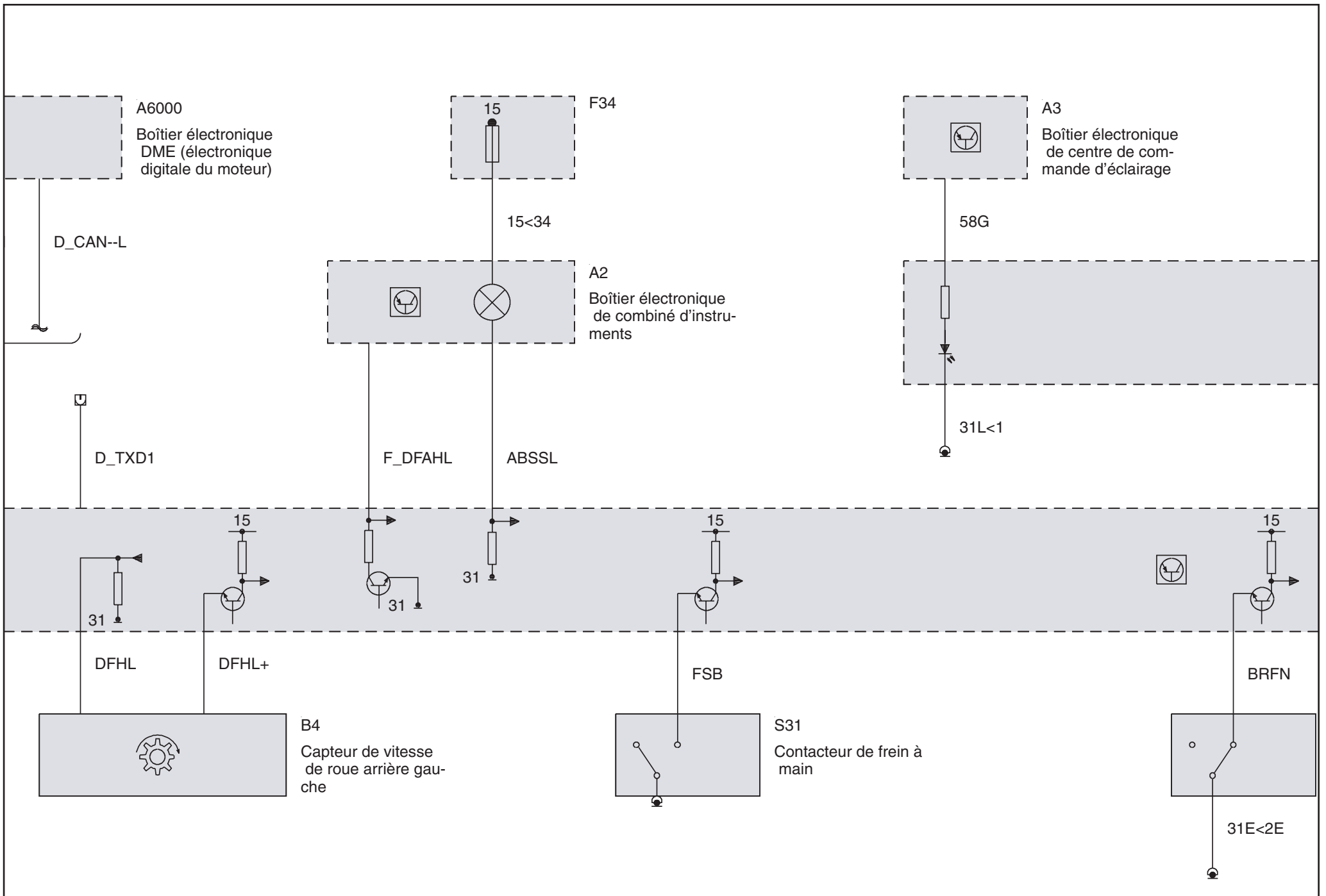



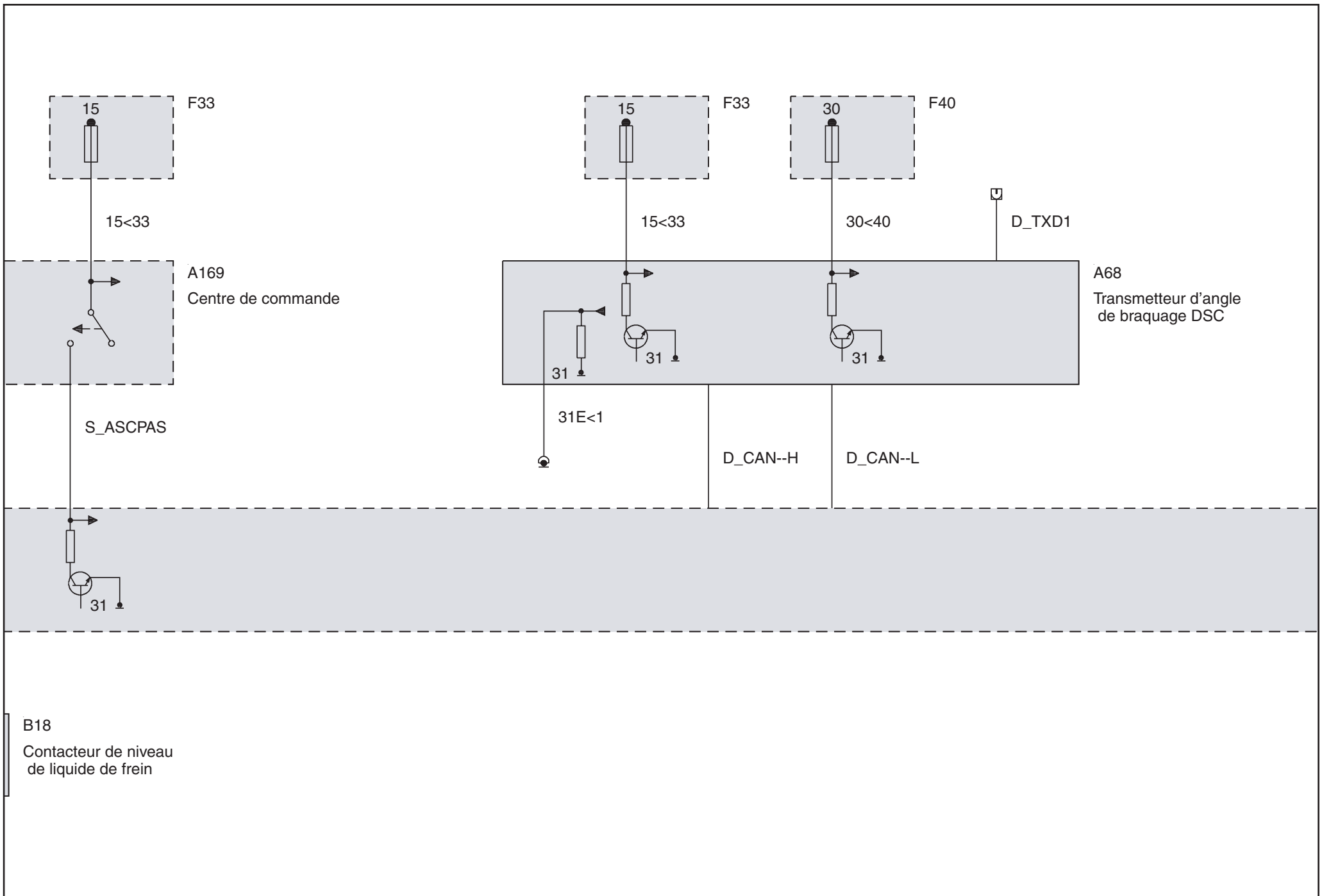

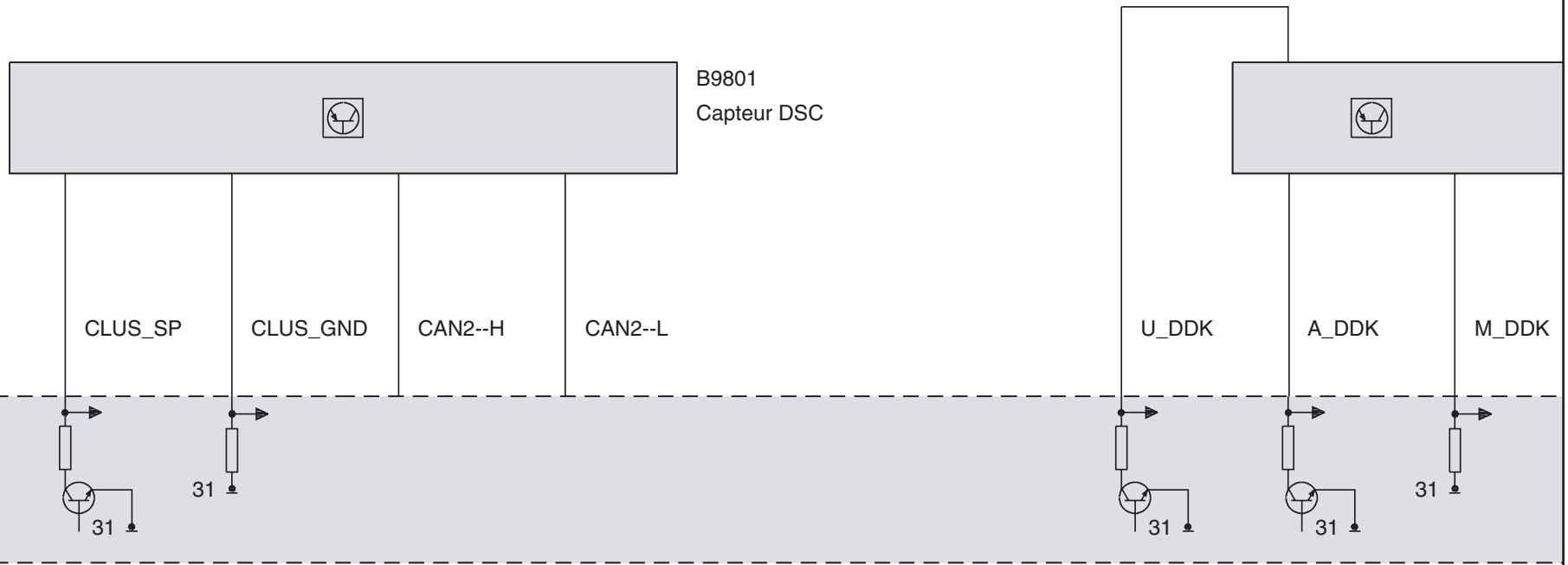

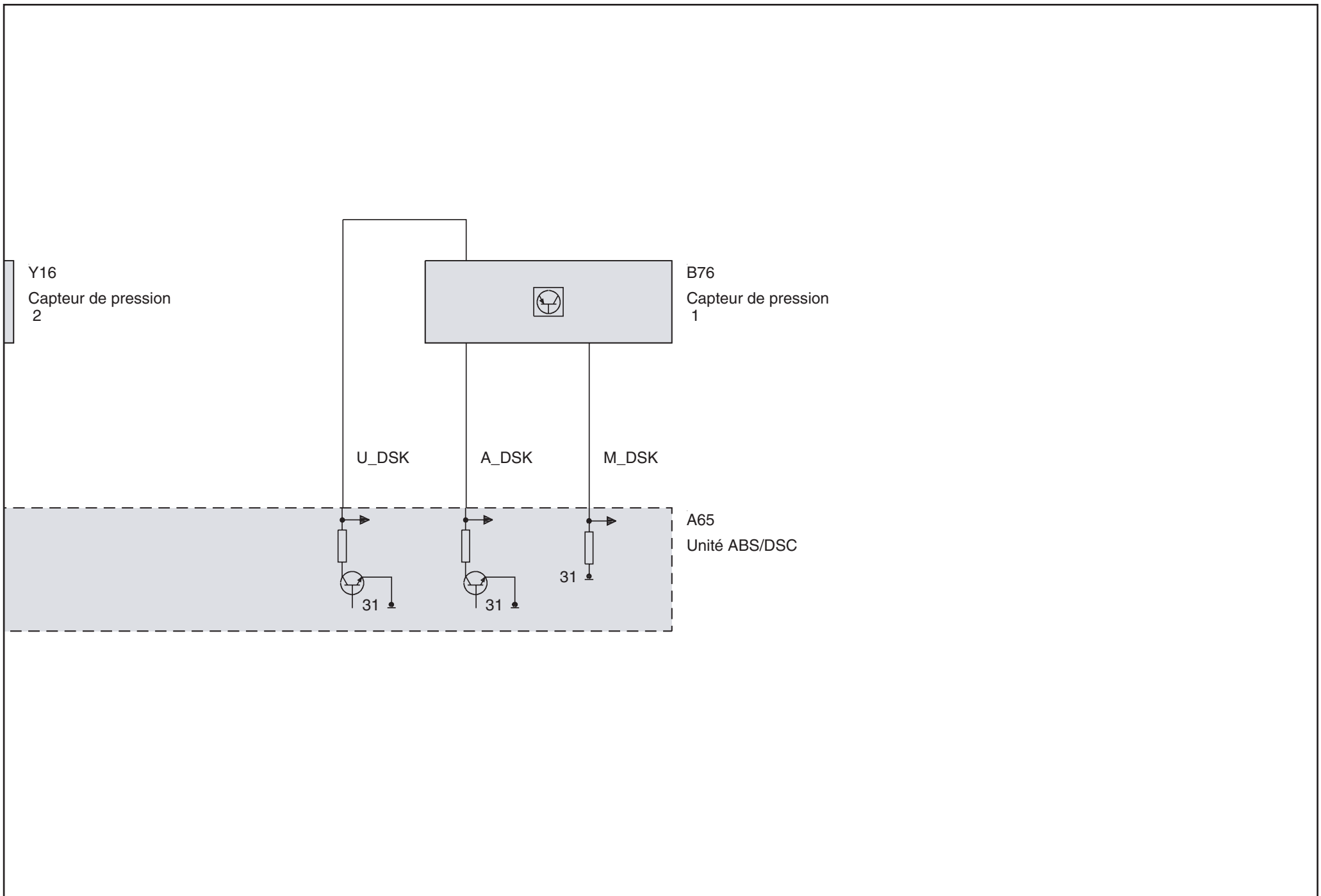

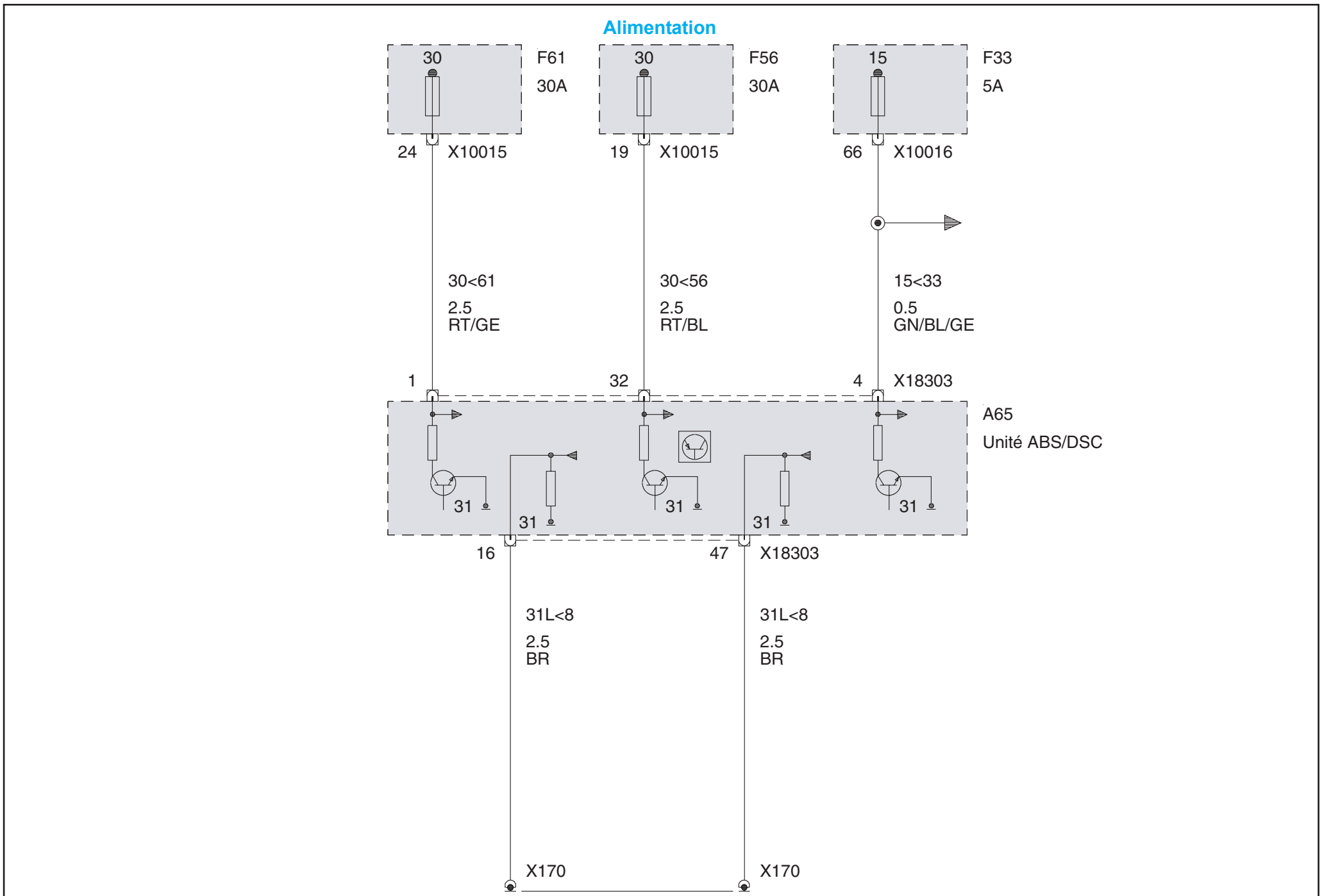

Touche DSC

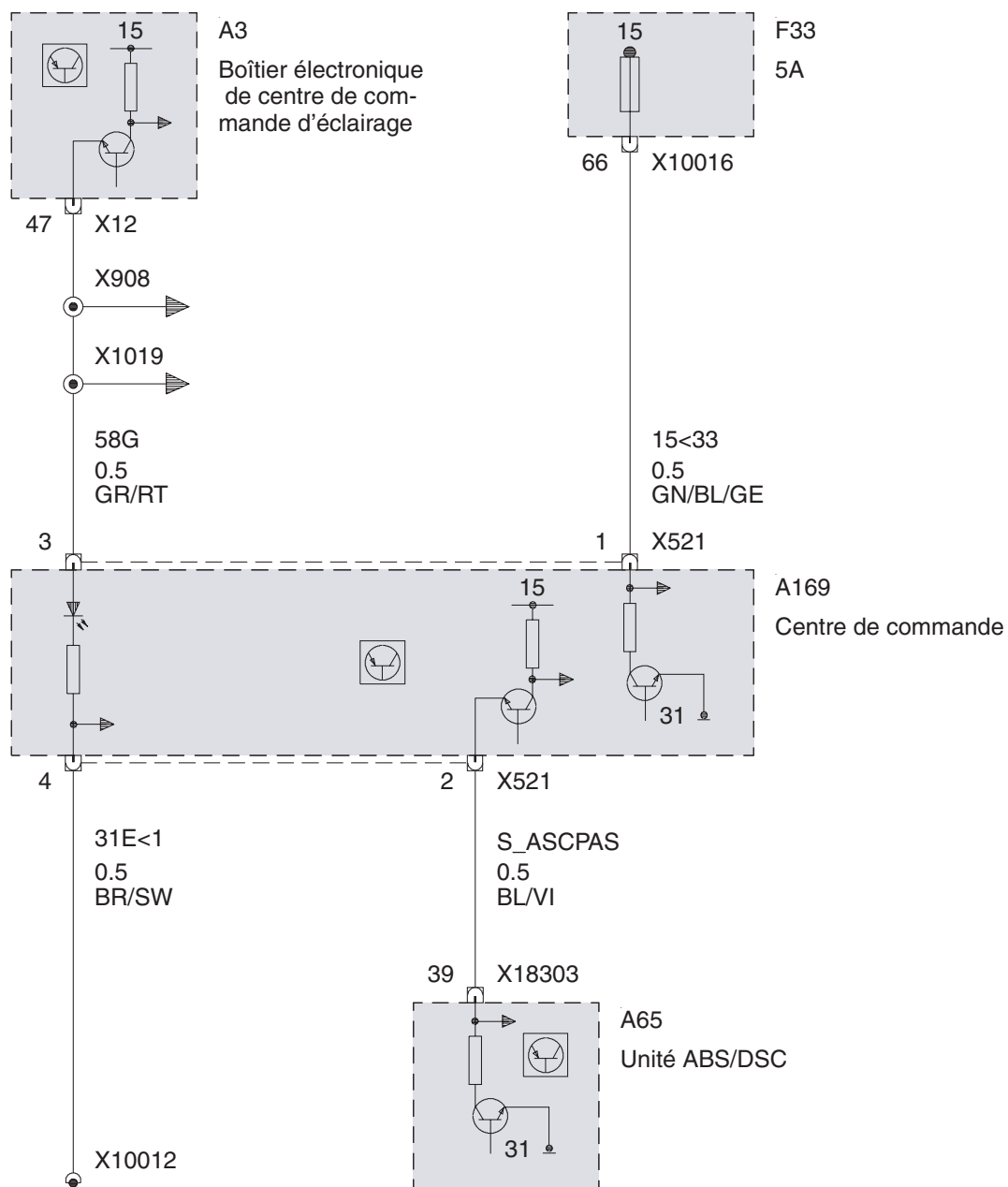

## Contacteur de feux stop (SMG Boîte de vitesses manuelle séquentielle)

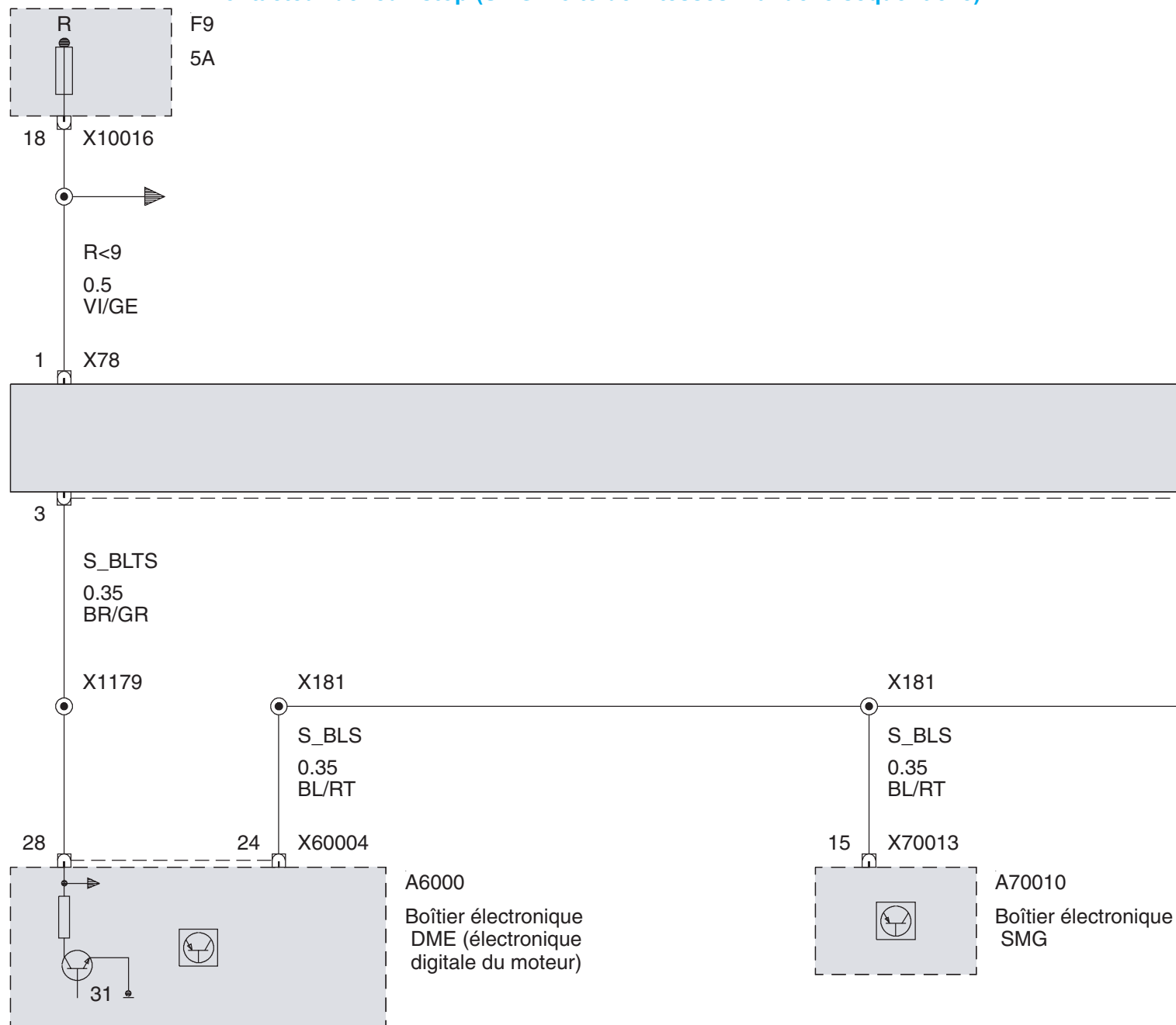

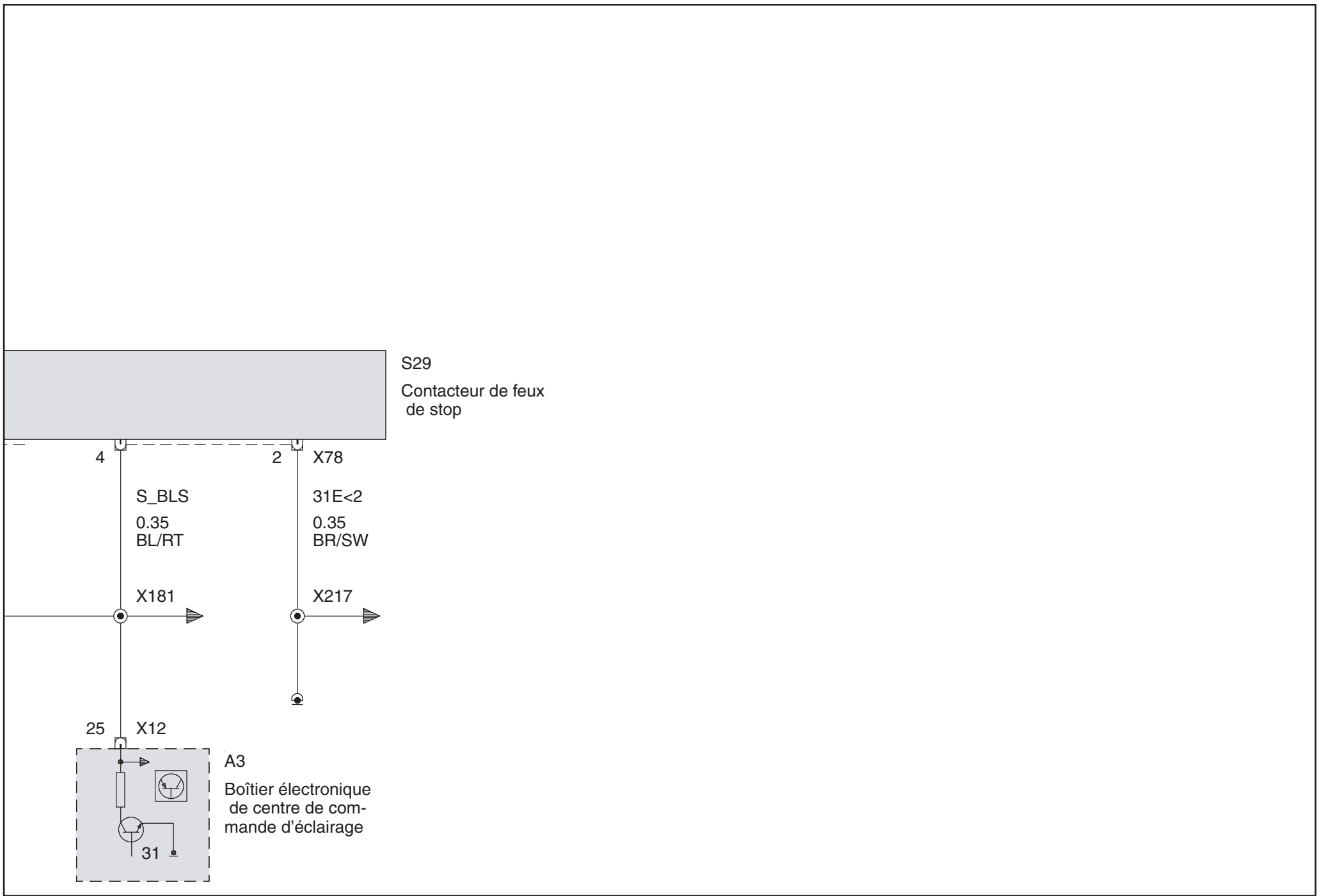

Contacteur de feux stop (DDE Electronique Diesel DDE50)

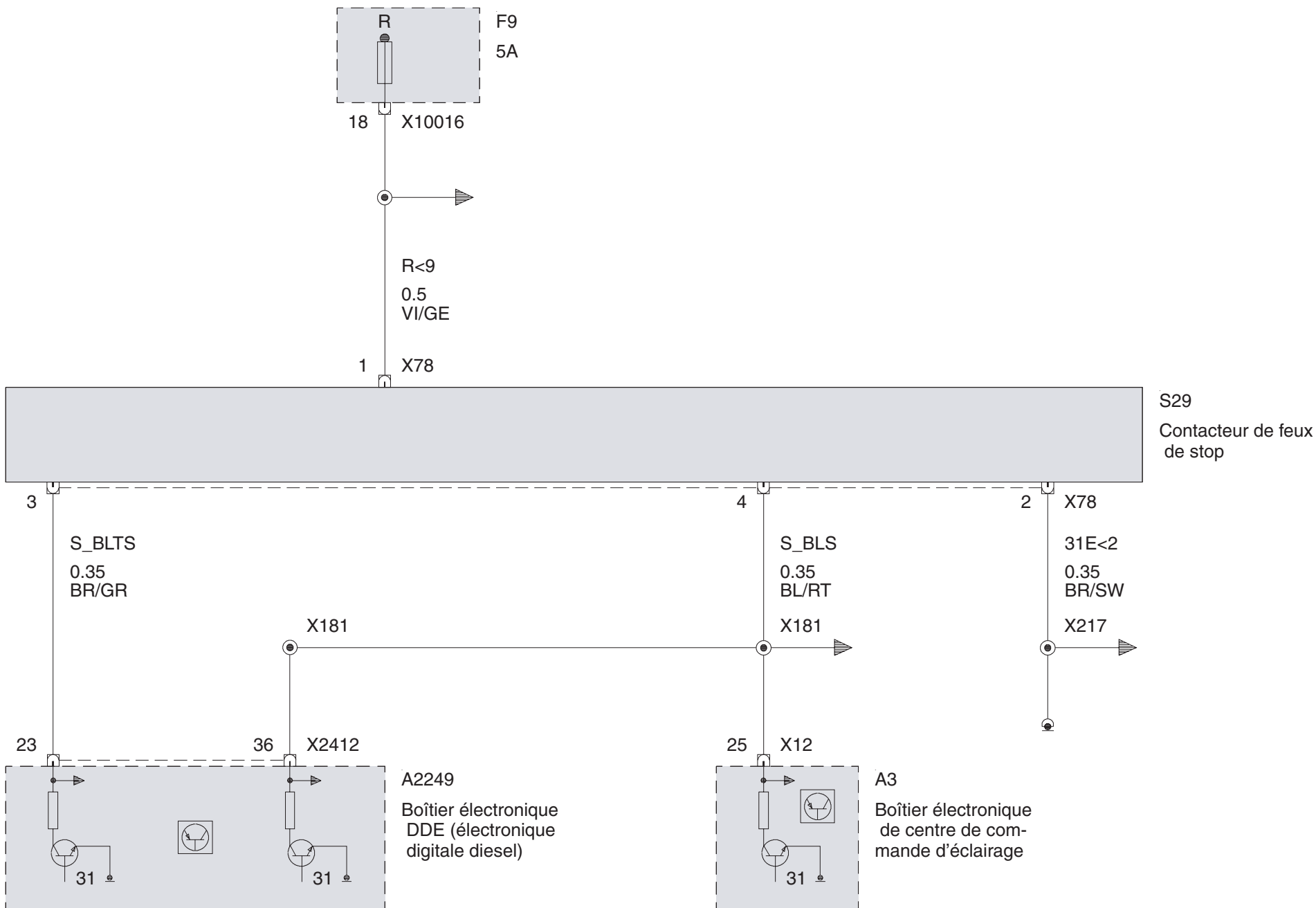



Contacteur de feux stop (Essence)

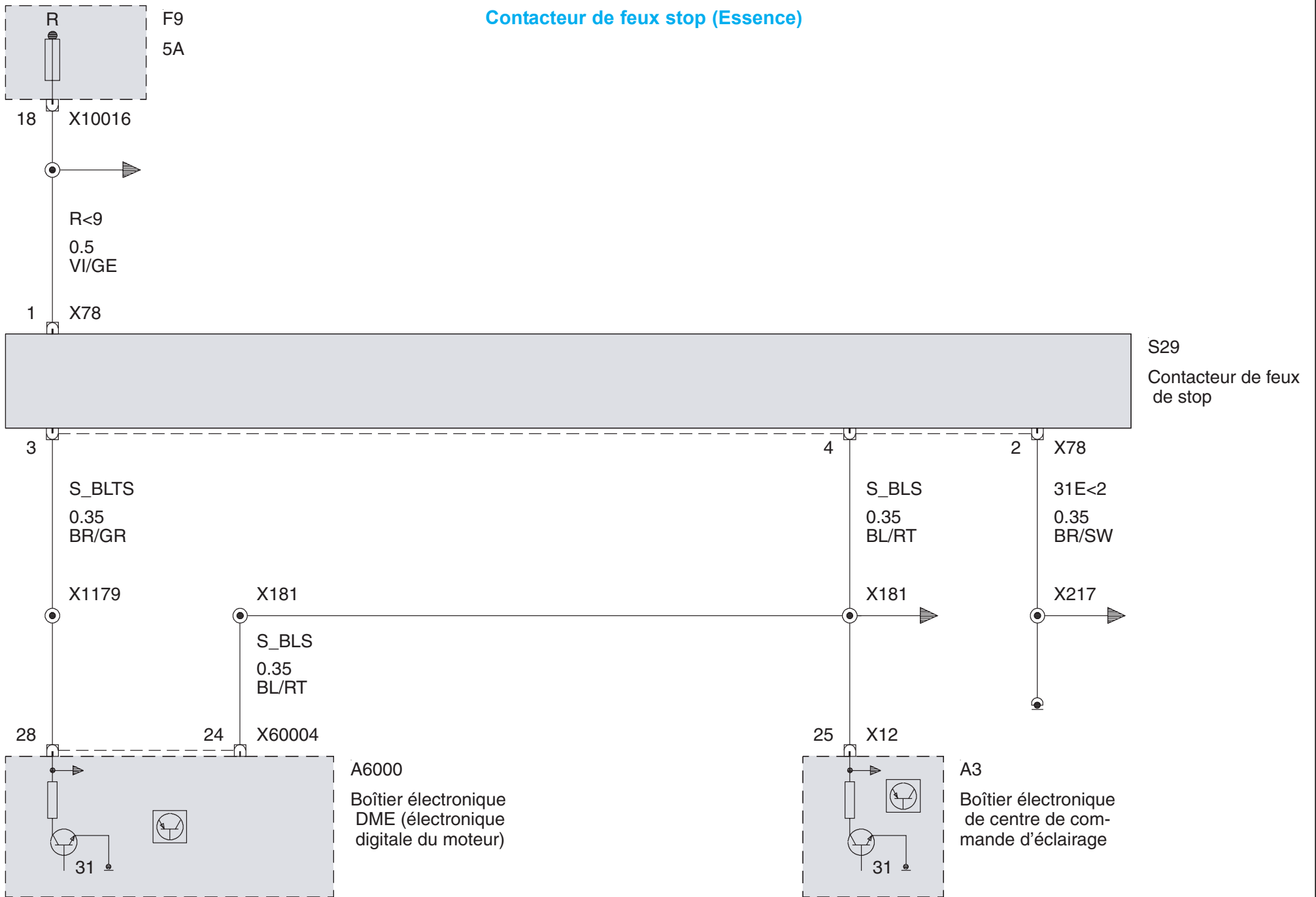

Contacteur de frein à main

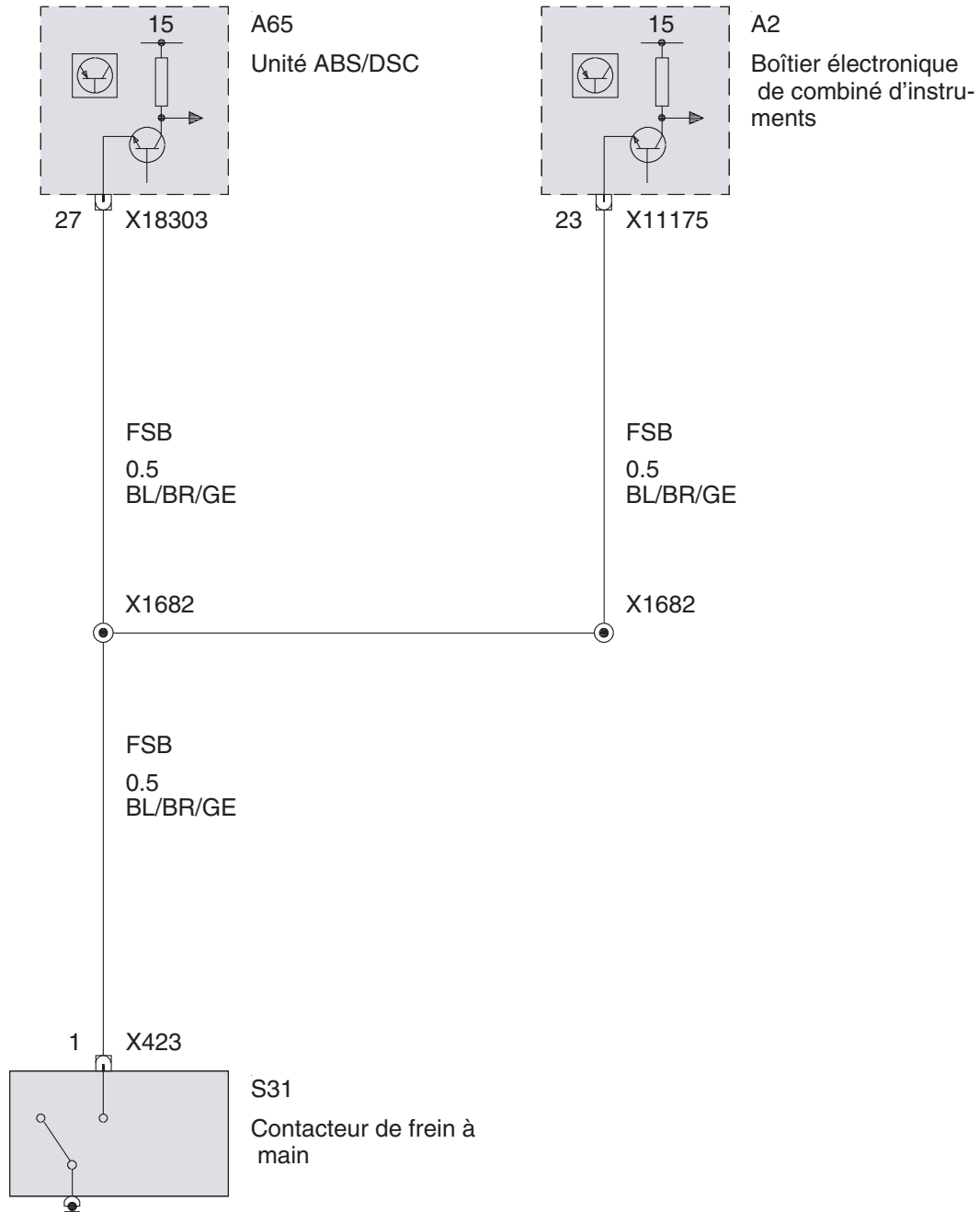

Capteur de taux de dérive

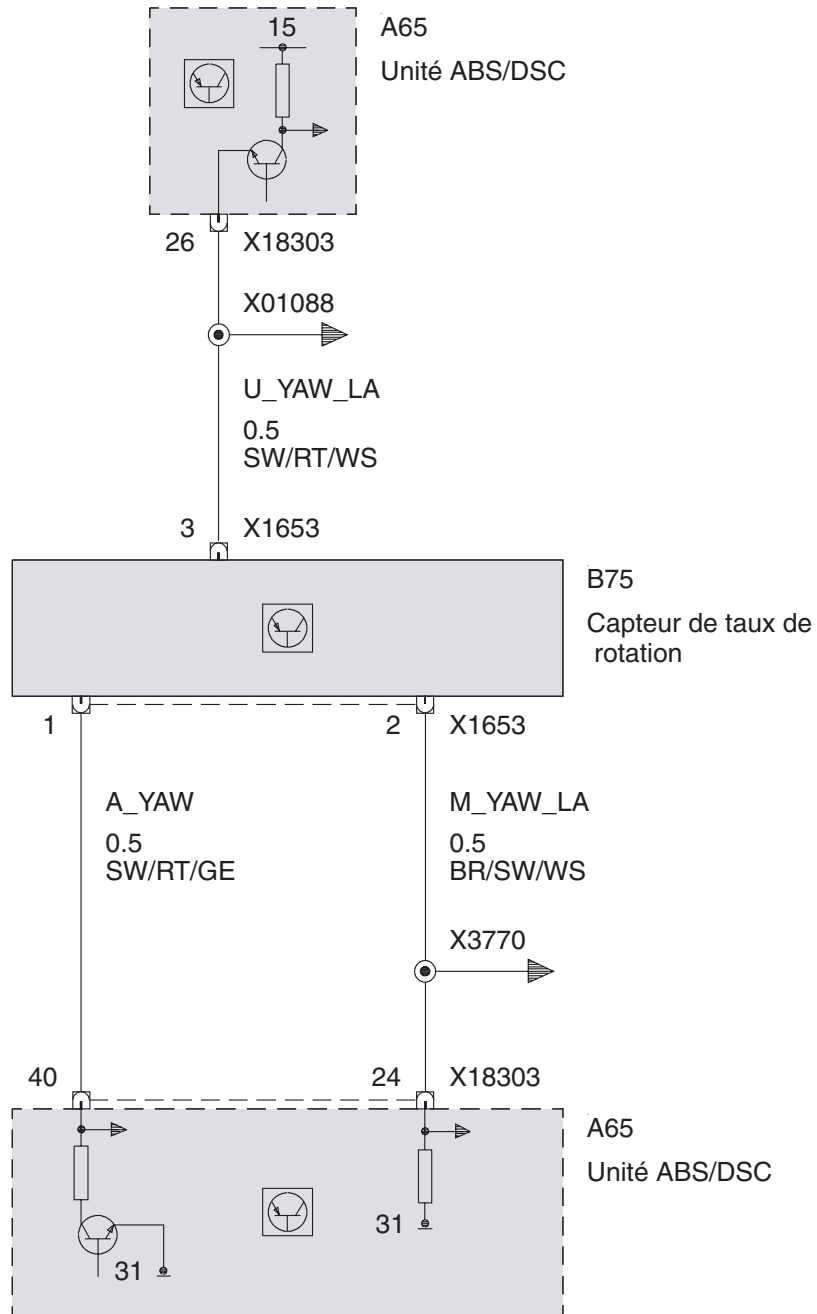

Capteur de vitesse de roue avant

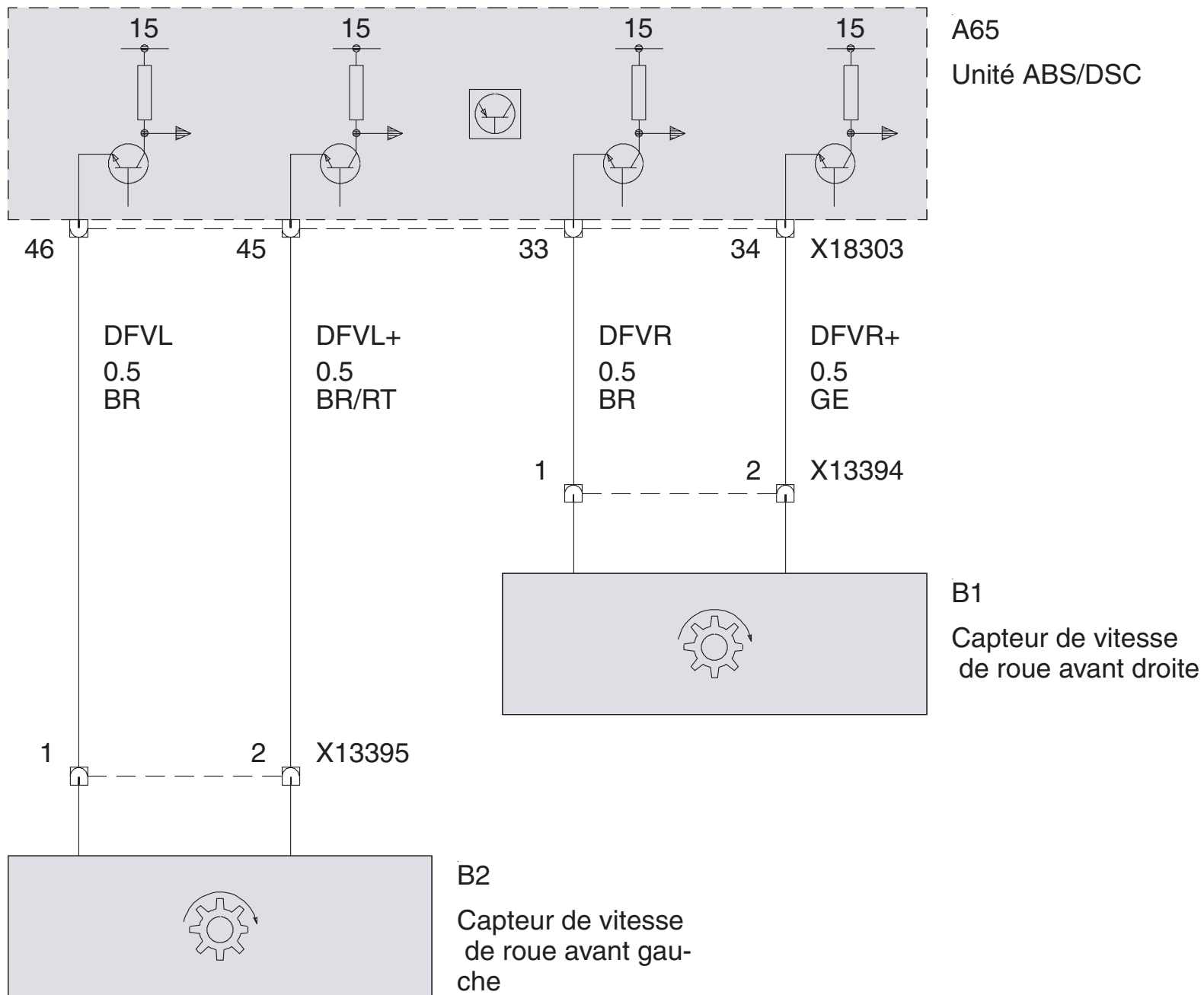

Capteur de vitesse de roue arrière

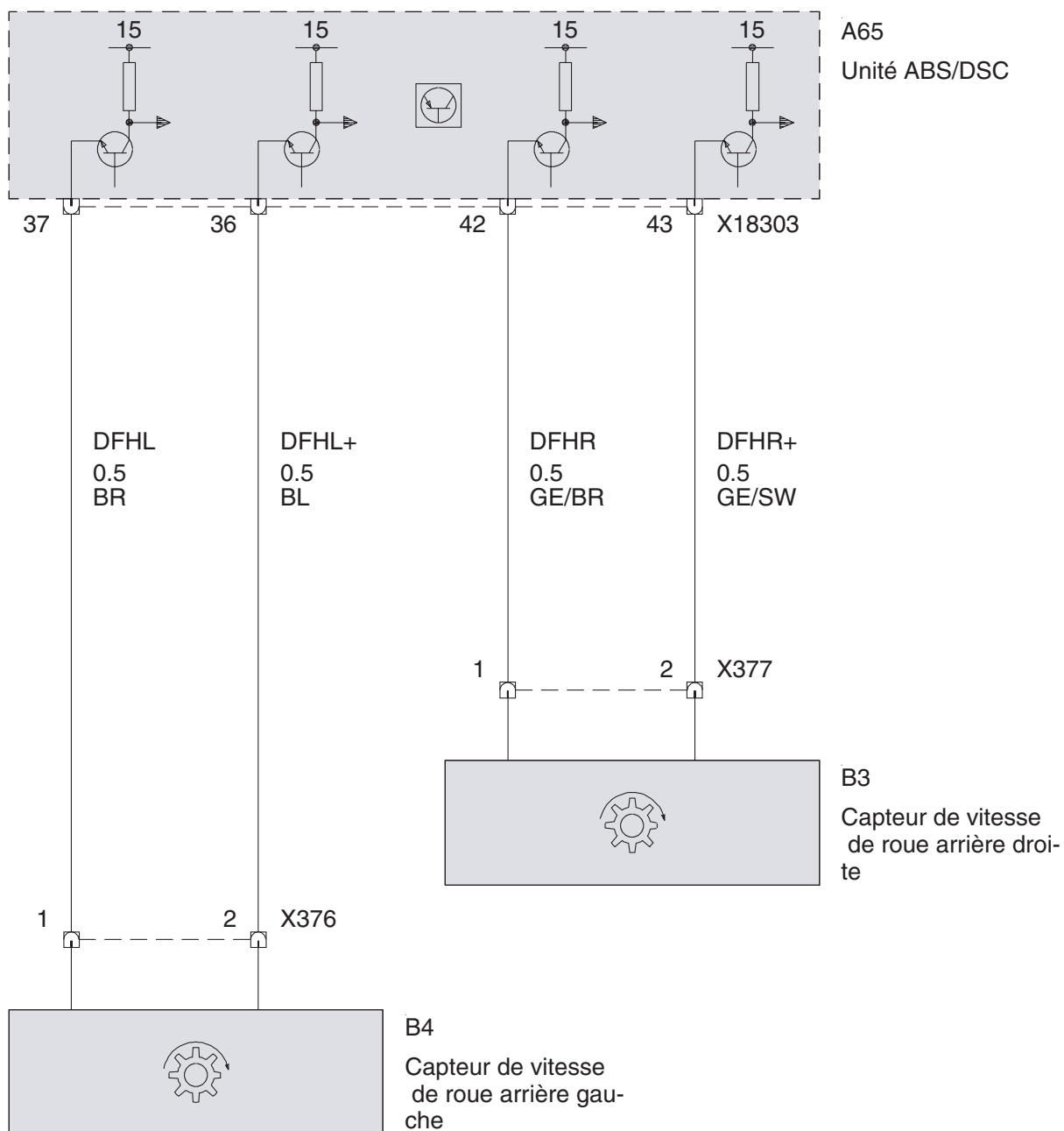

Capteur d'accélération transversale

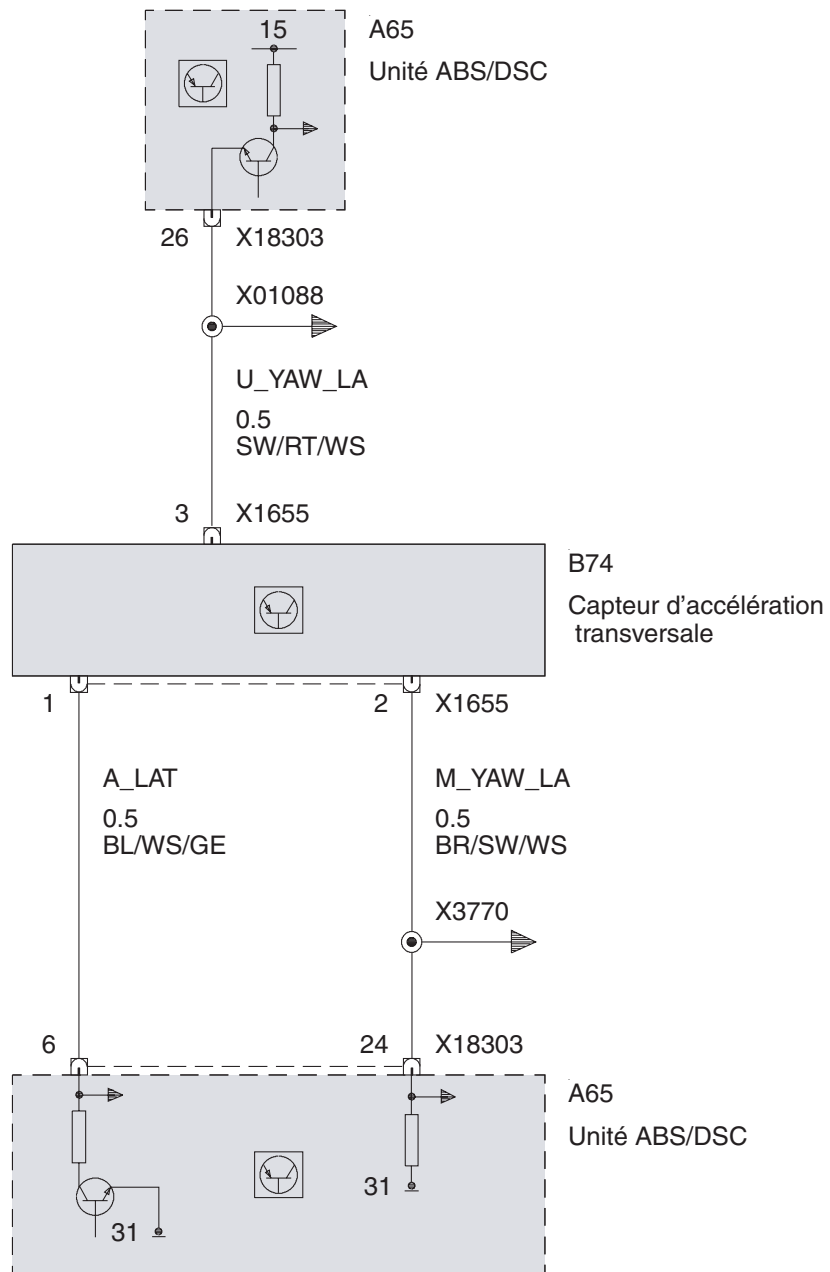

Capteur DSC

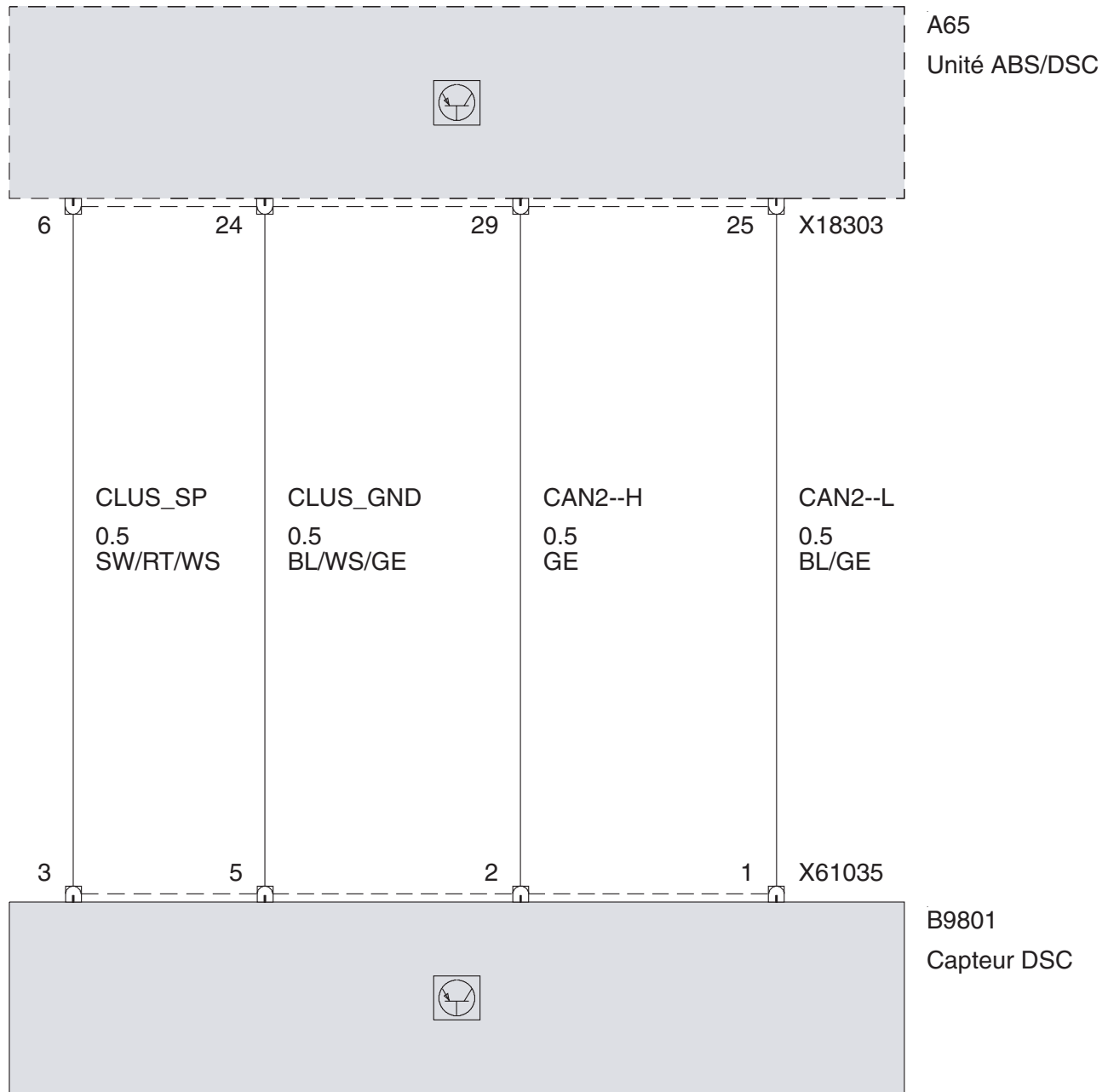

Capteur de pression 1

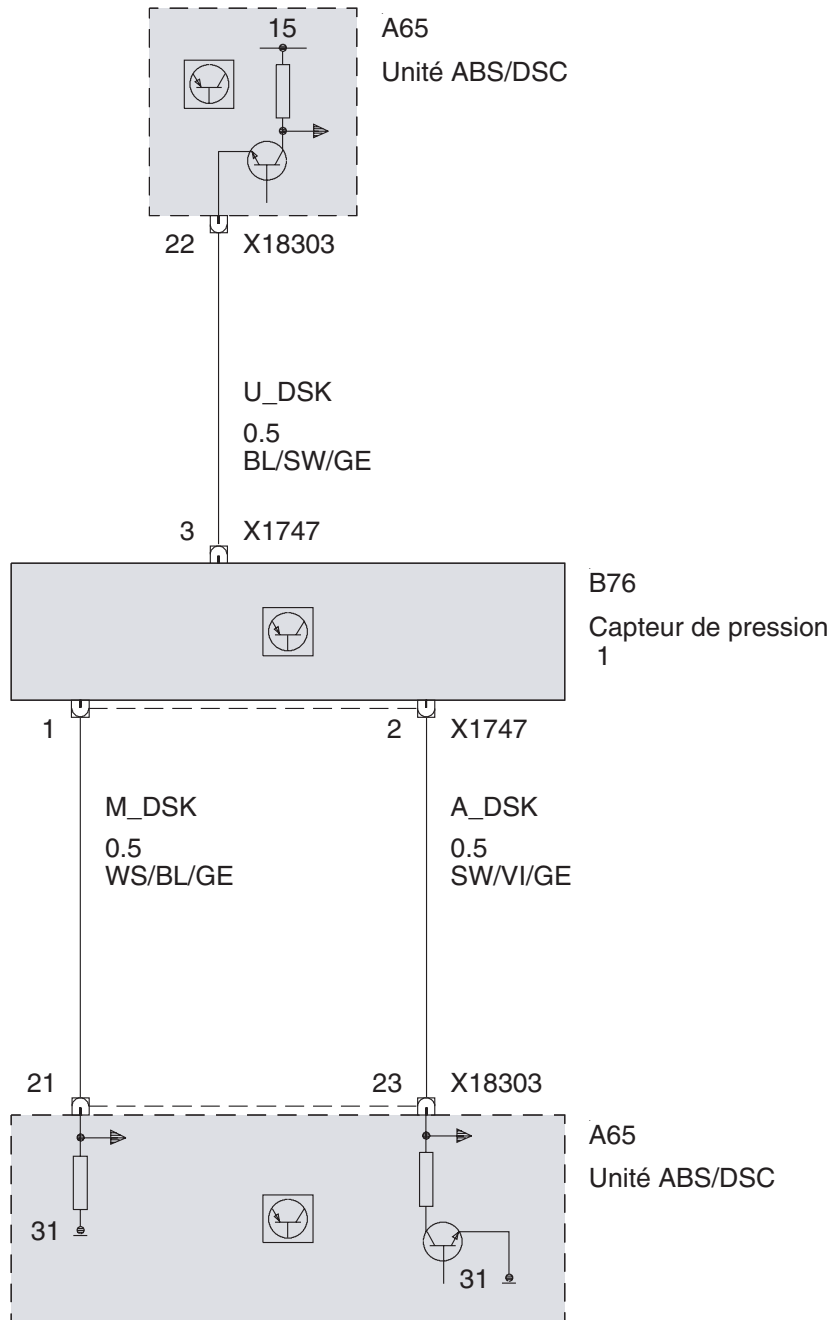



Capteur de pression 2

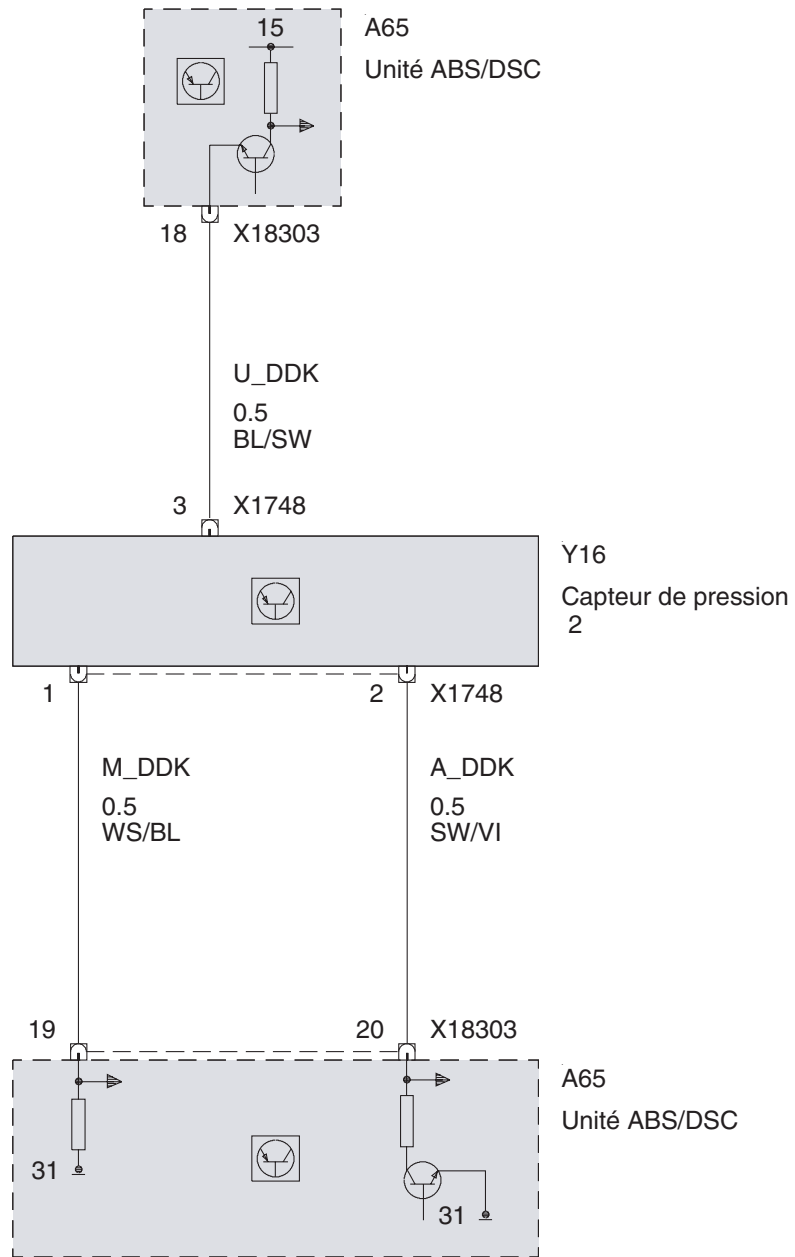

Capteur d'angle de braquage

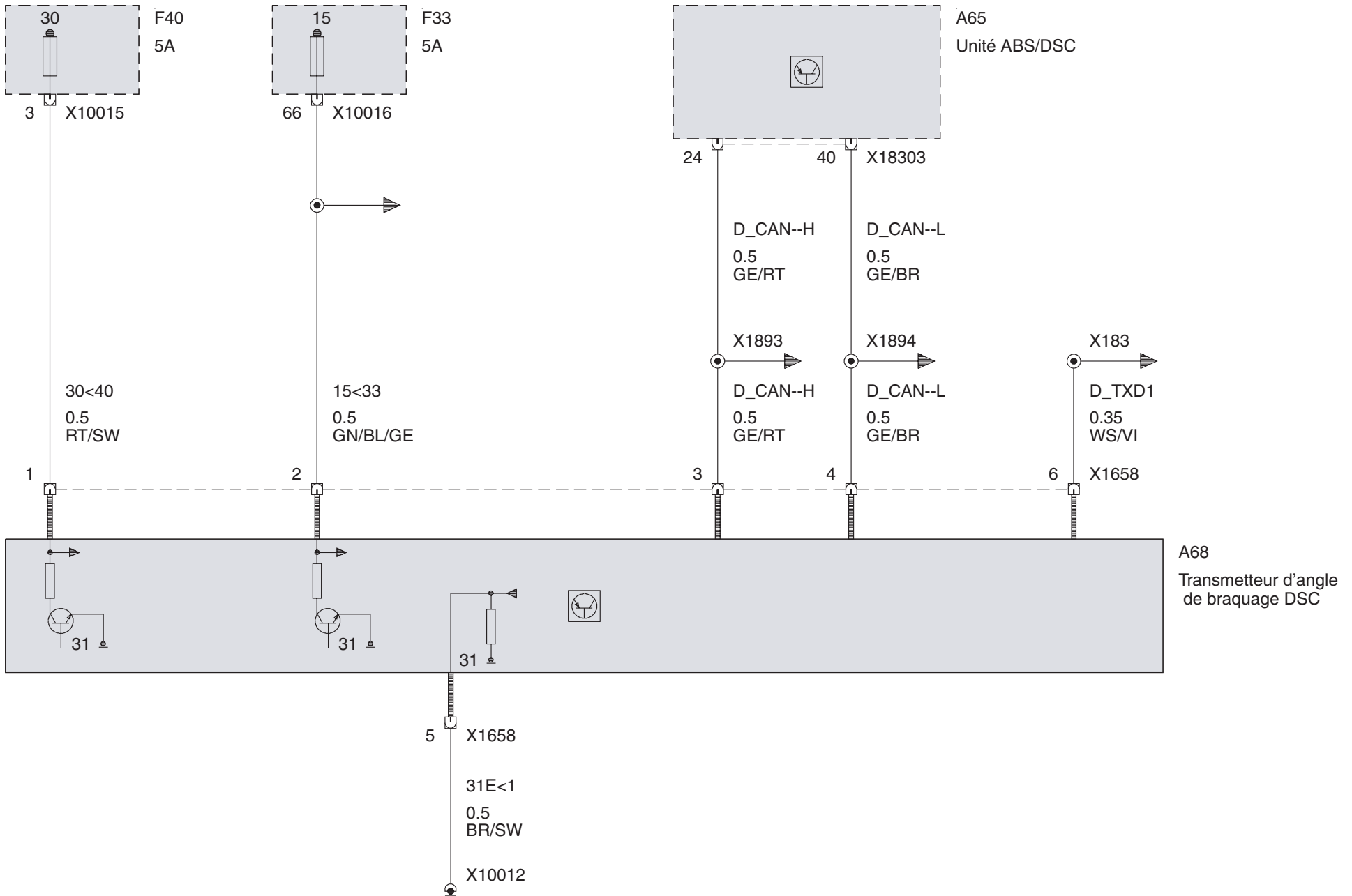

Capteur de niveau liquide de frein

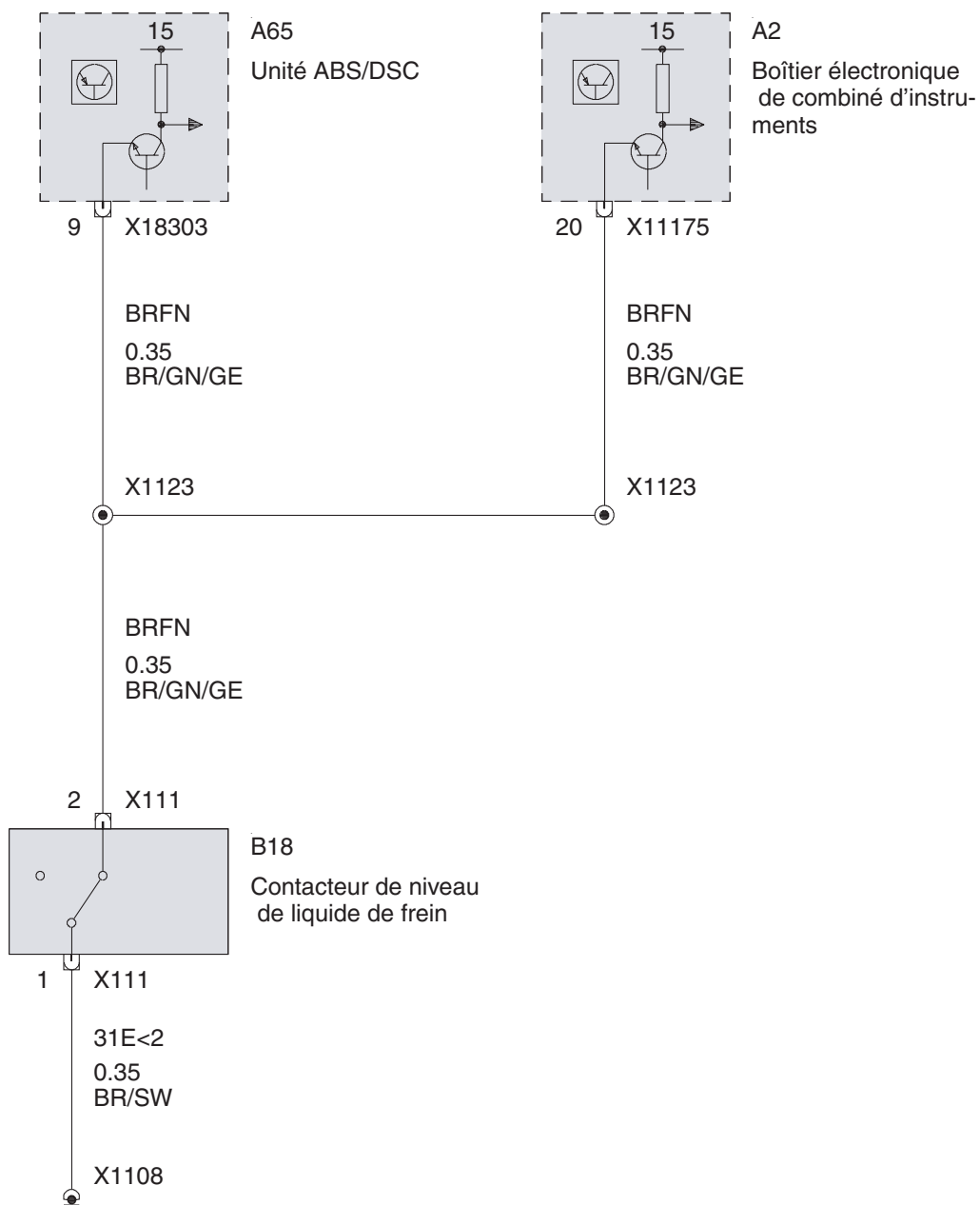

### Affichages et informations

Fonctions d'affichage et d'information (avec Essence et ASC MK20 contrôle automatique de stabilité)

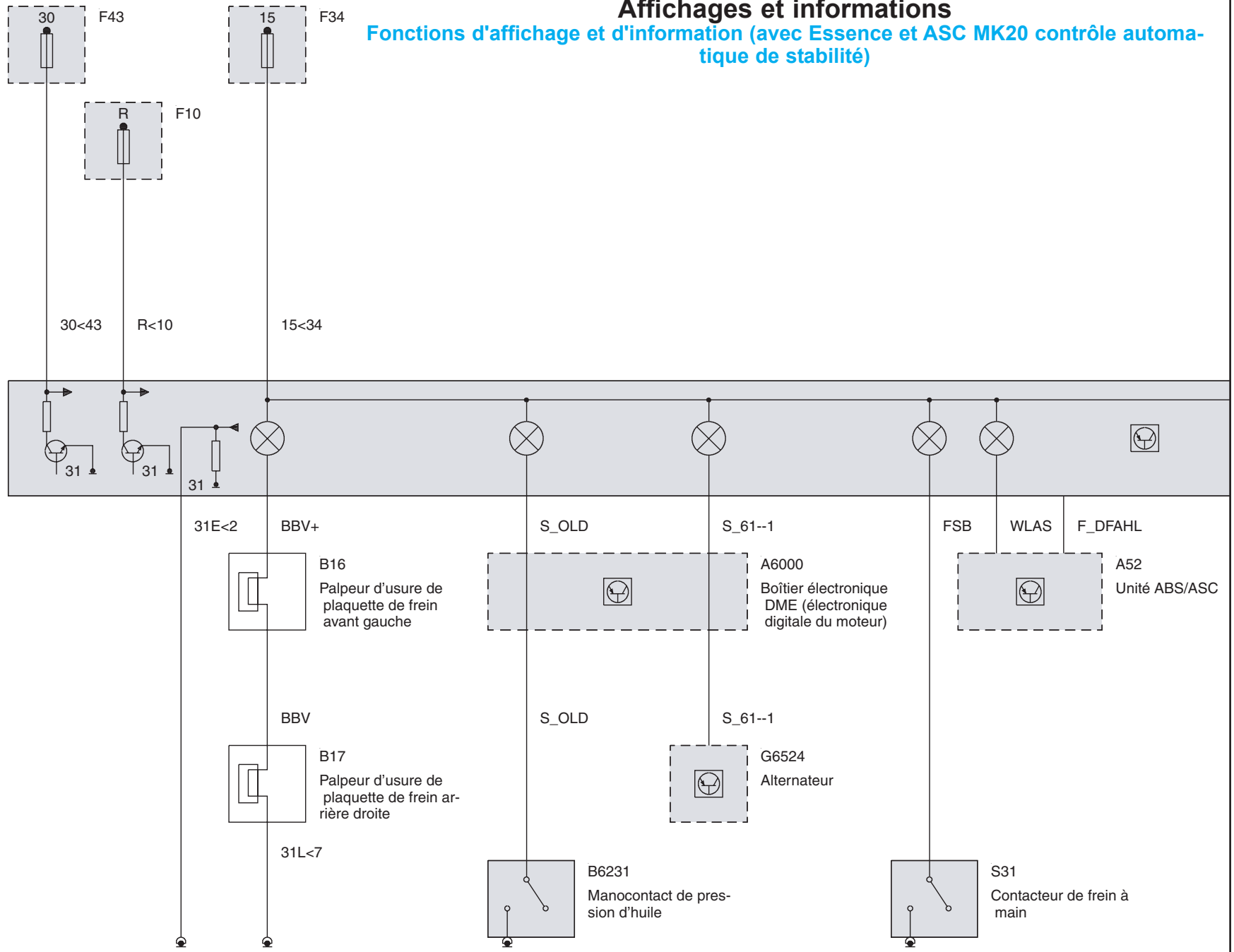

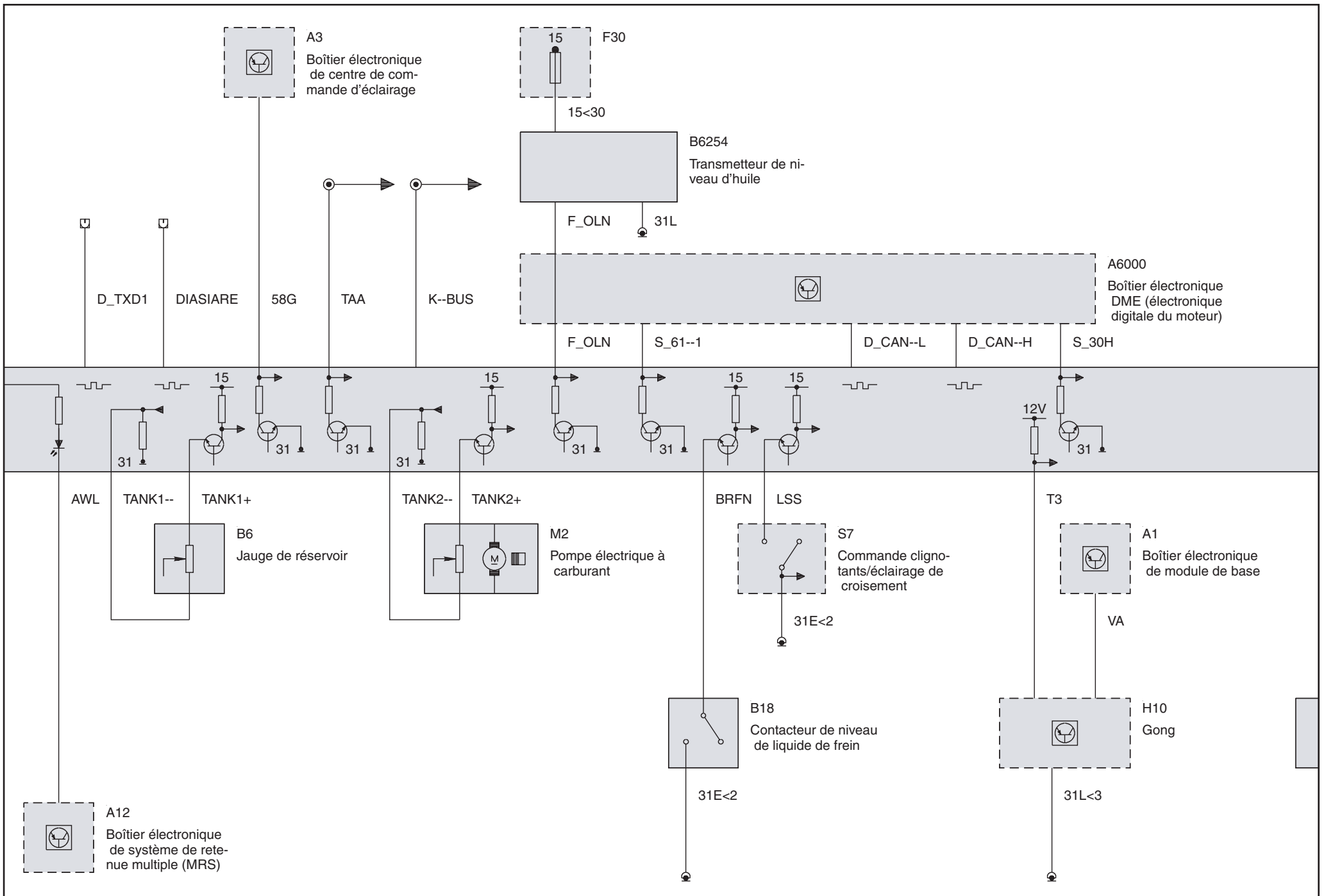

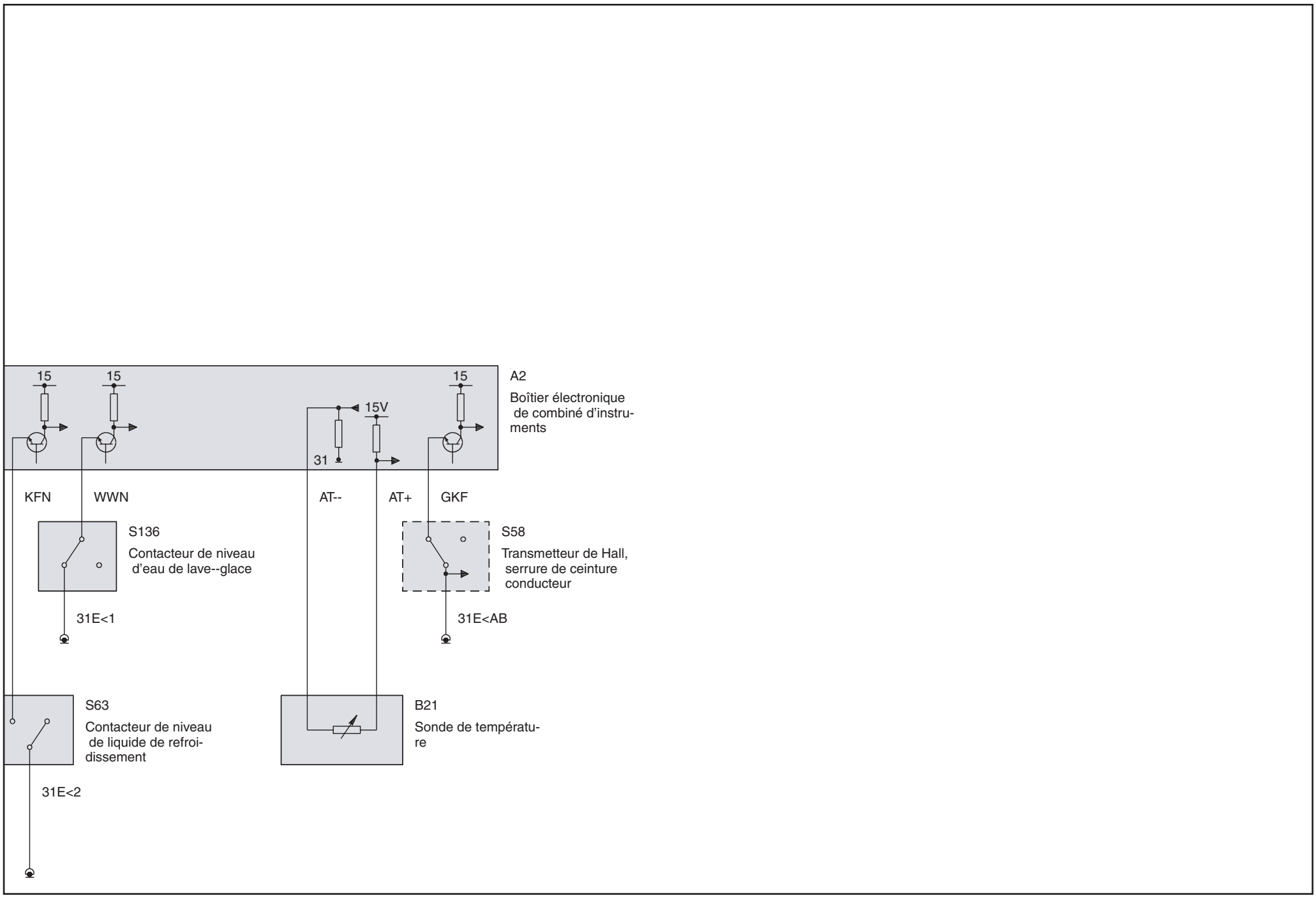

Fonctions d'affichage et d'information (avec Essence et DSC MK20 Contrôle dynamique de stabilité)

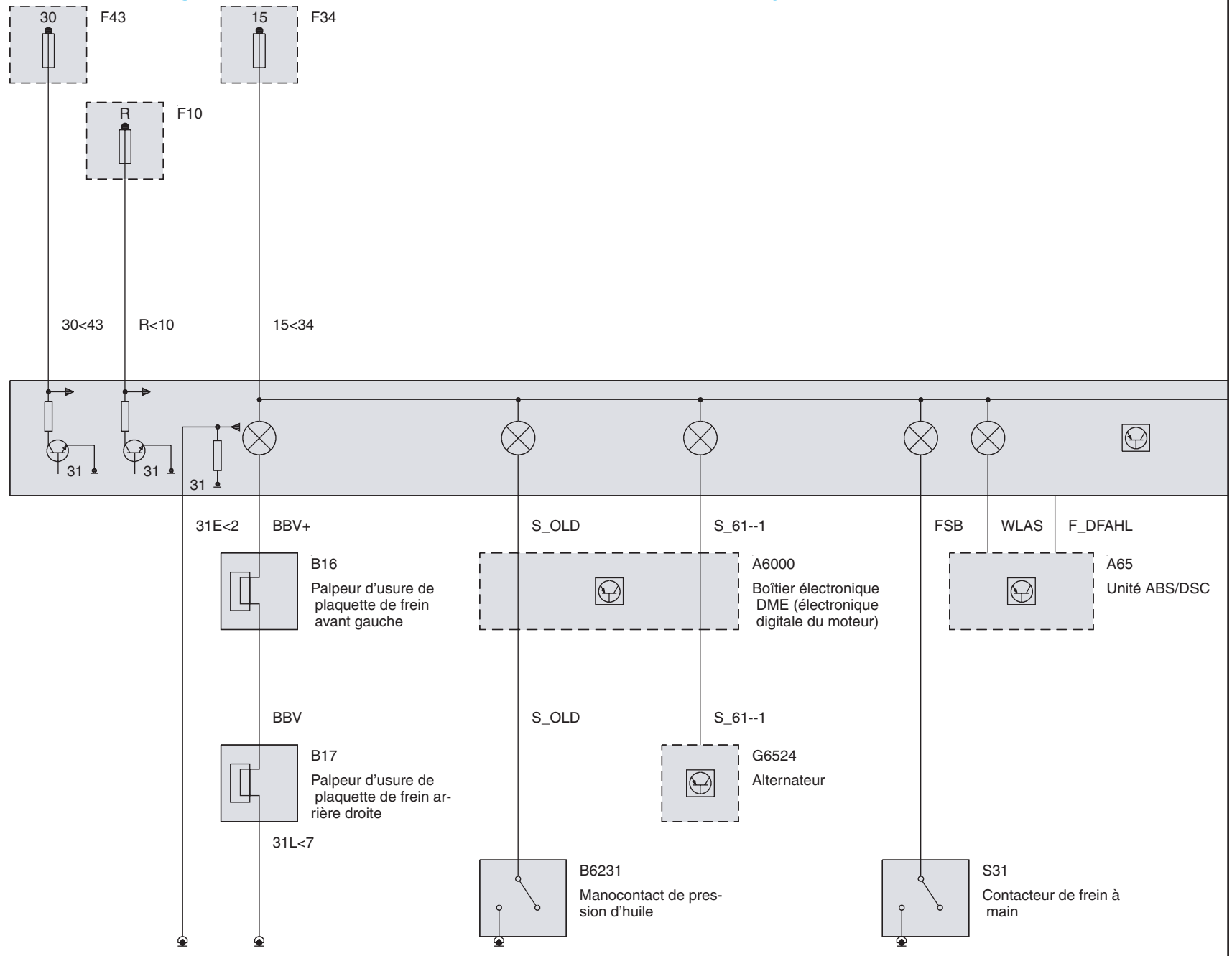

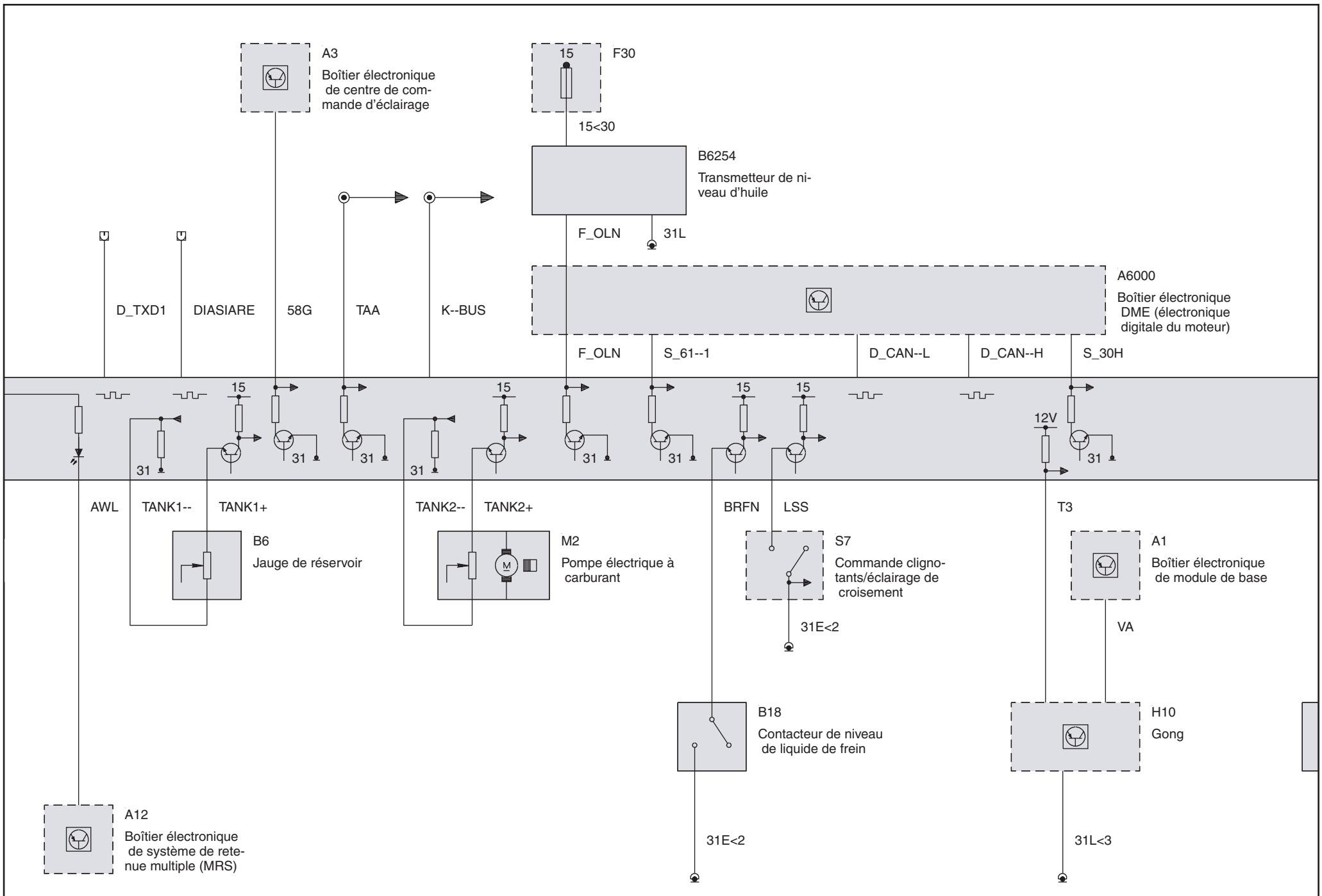



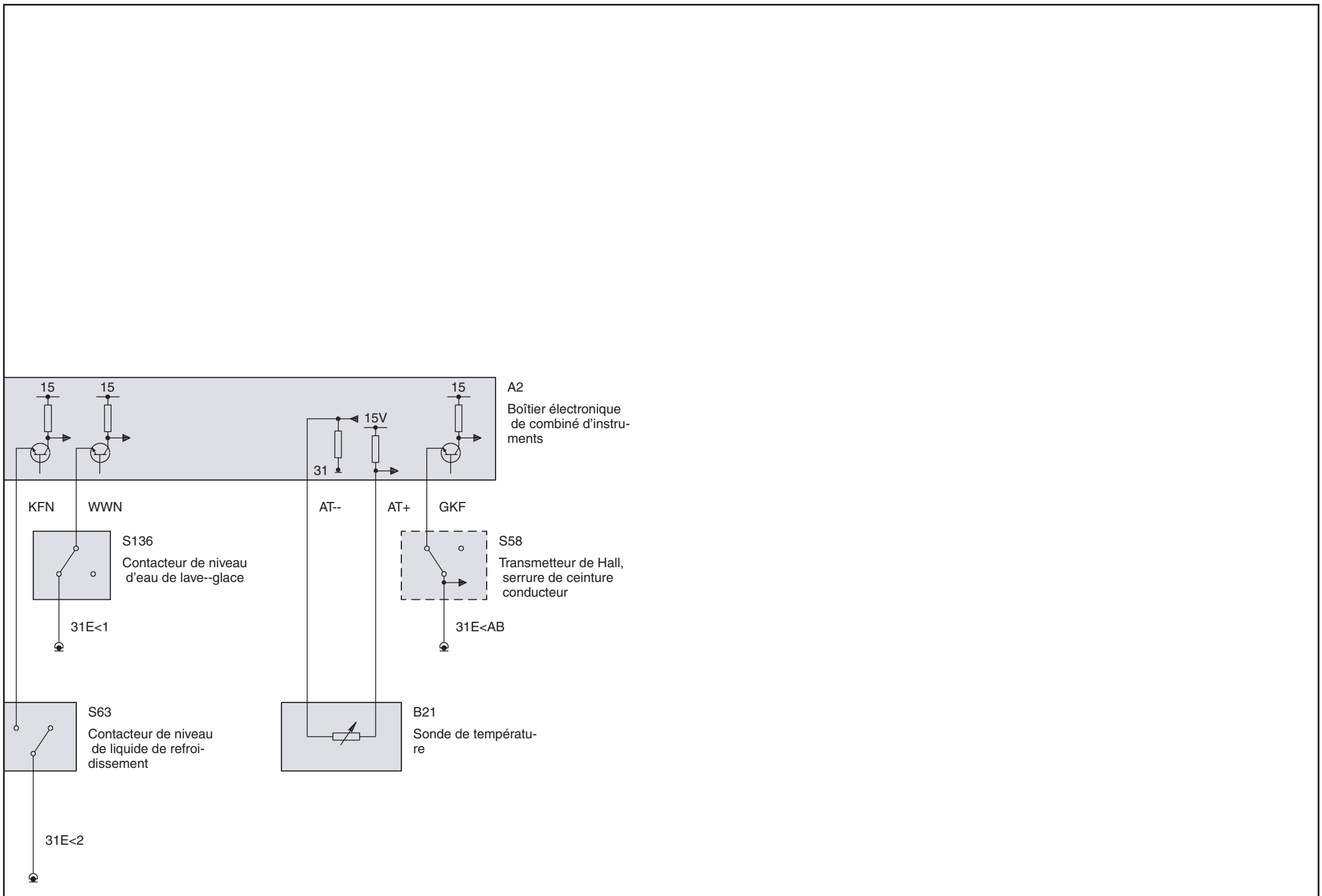

Fonctions d'affichage et d'information (avec Diesel et (ASC MK20 ou DSC MK20))

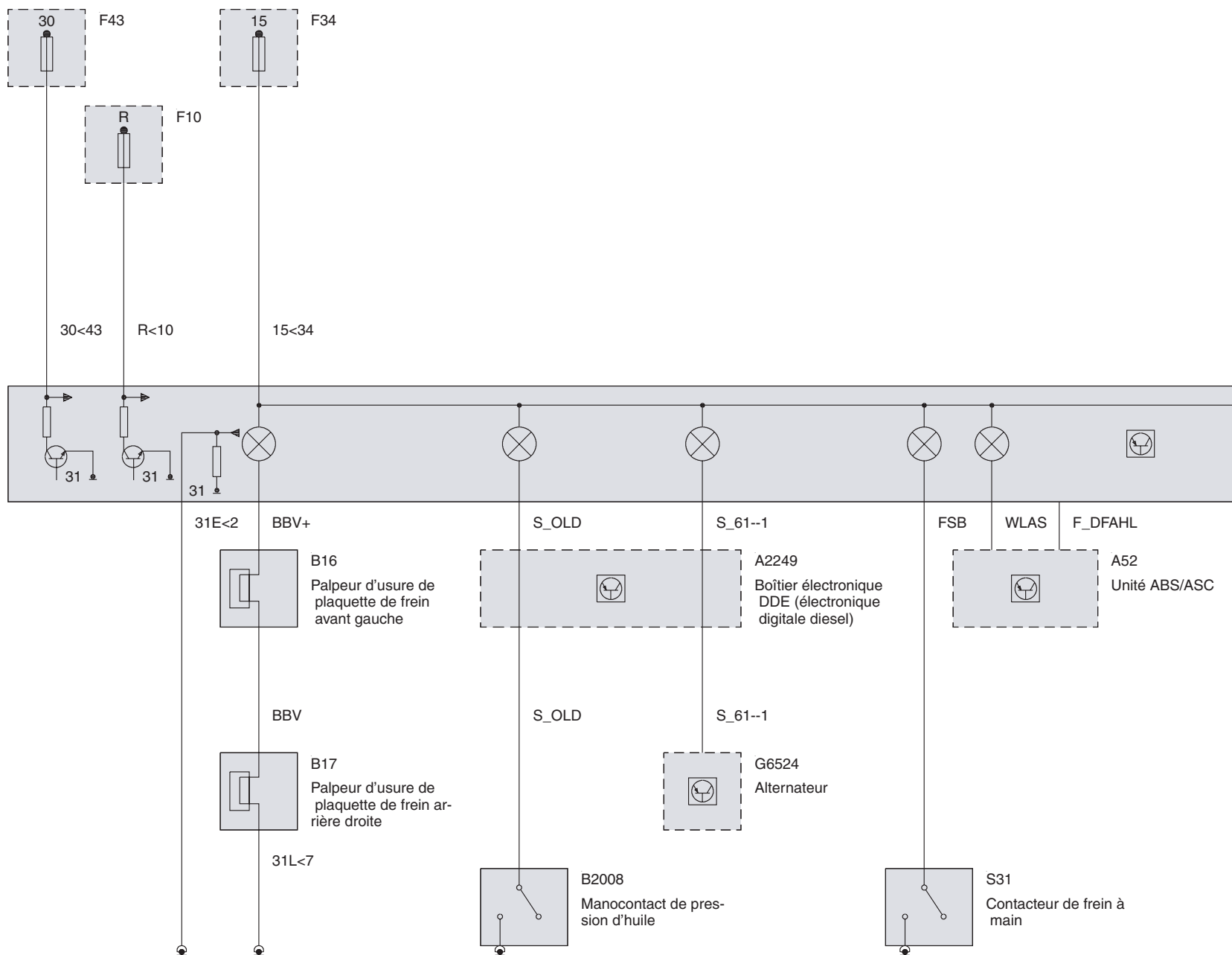

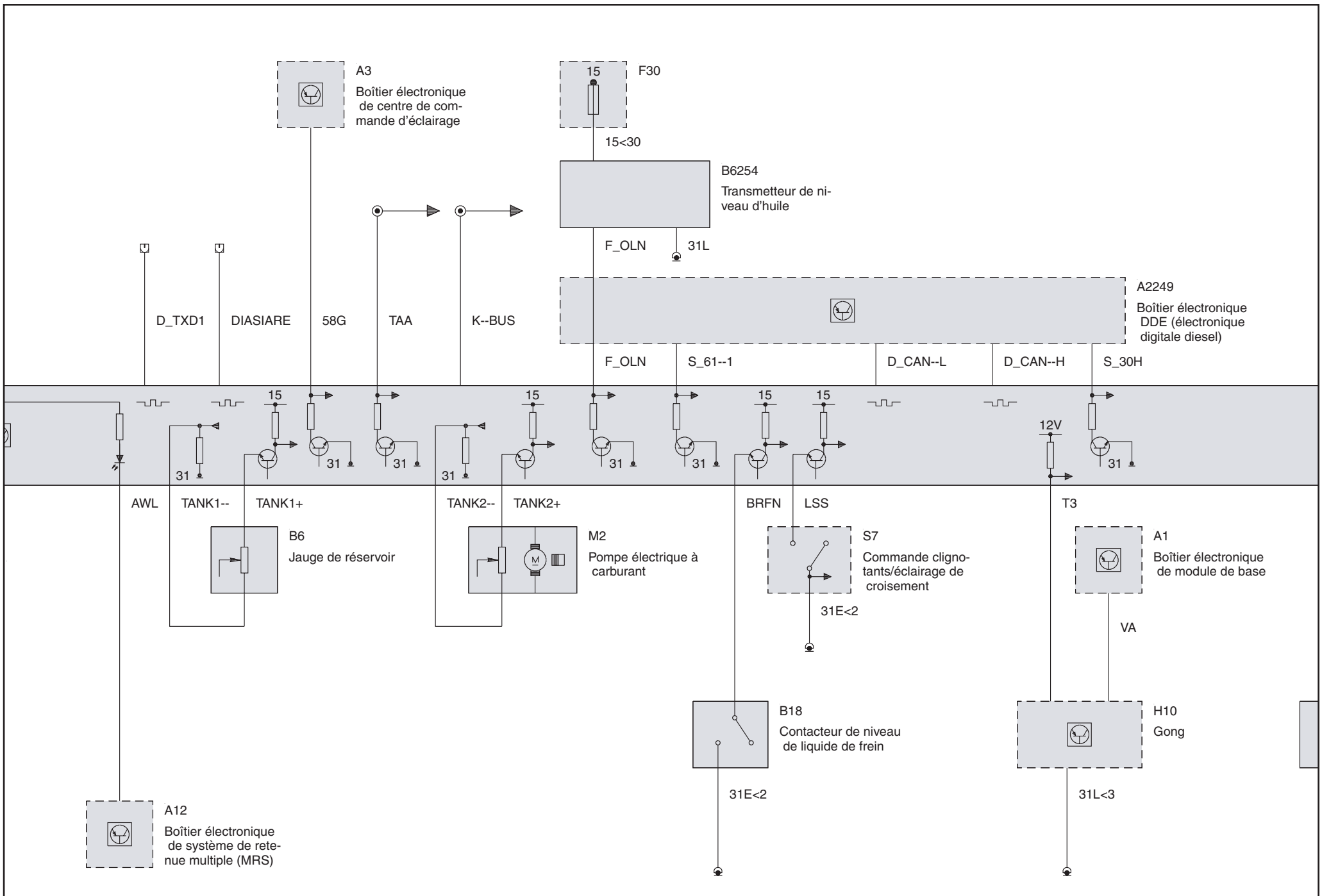

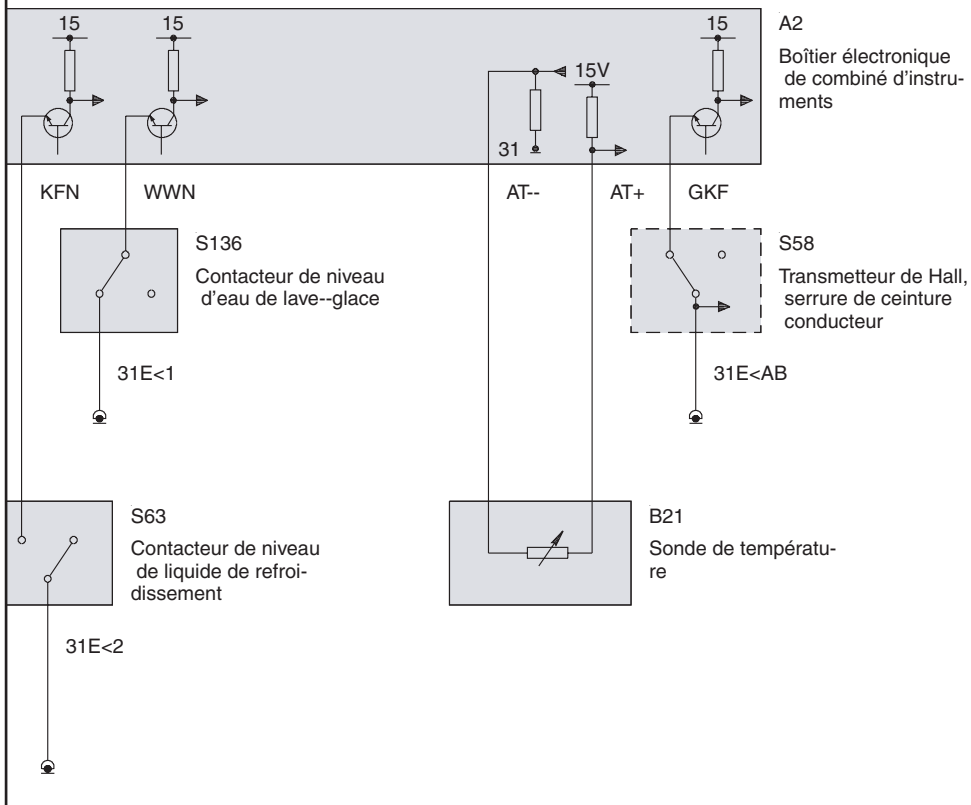

Fonctions d'affichage et d'information (DDE Electronique Diesel DDE50 avec ( ASC MK60 ou DSC MK60 ) jusque 2002\_09)

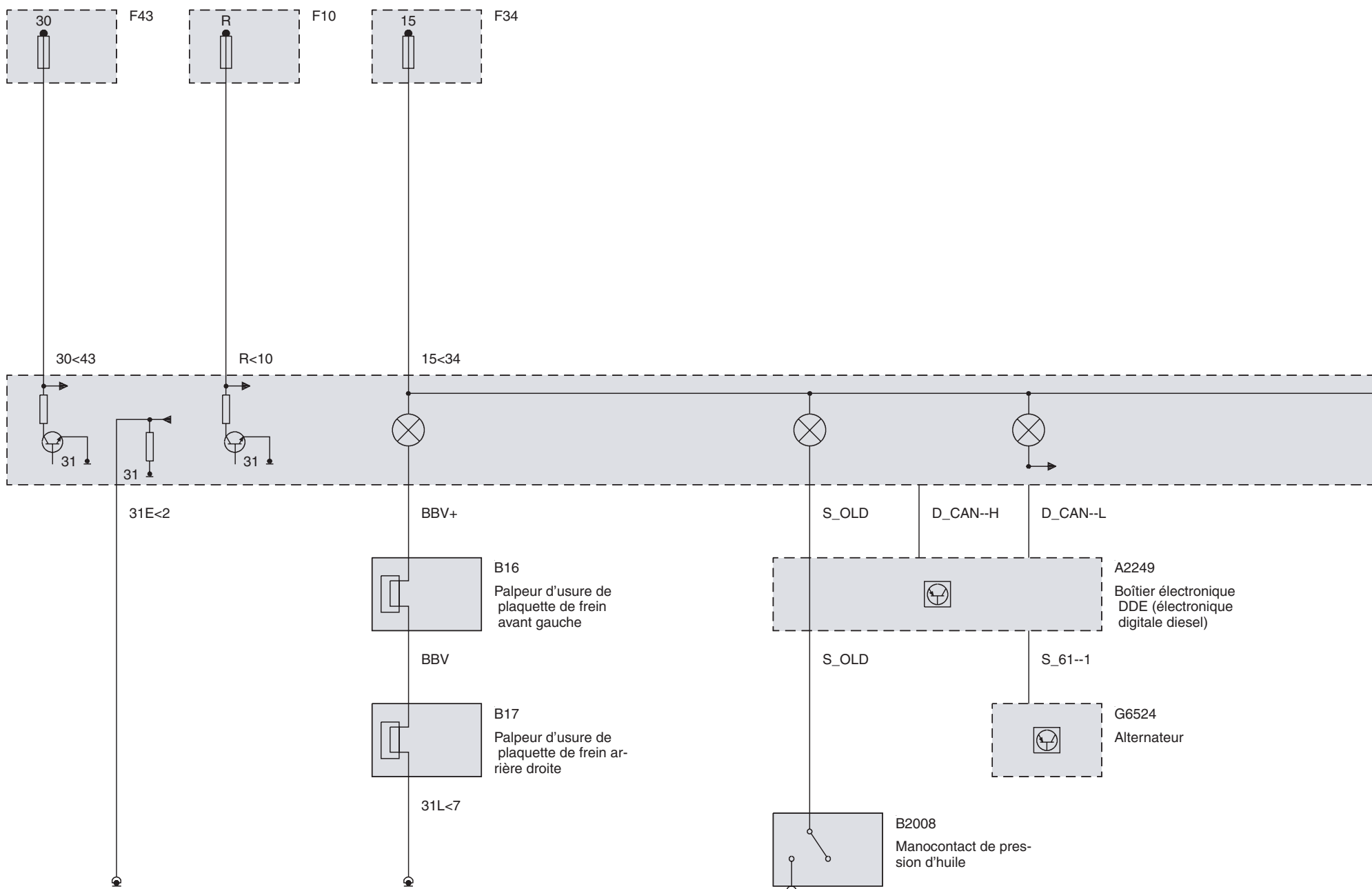

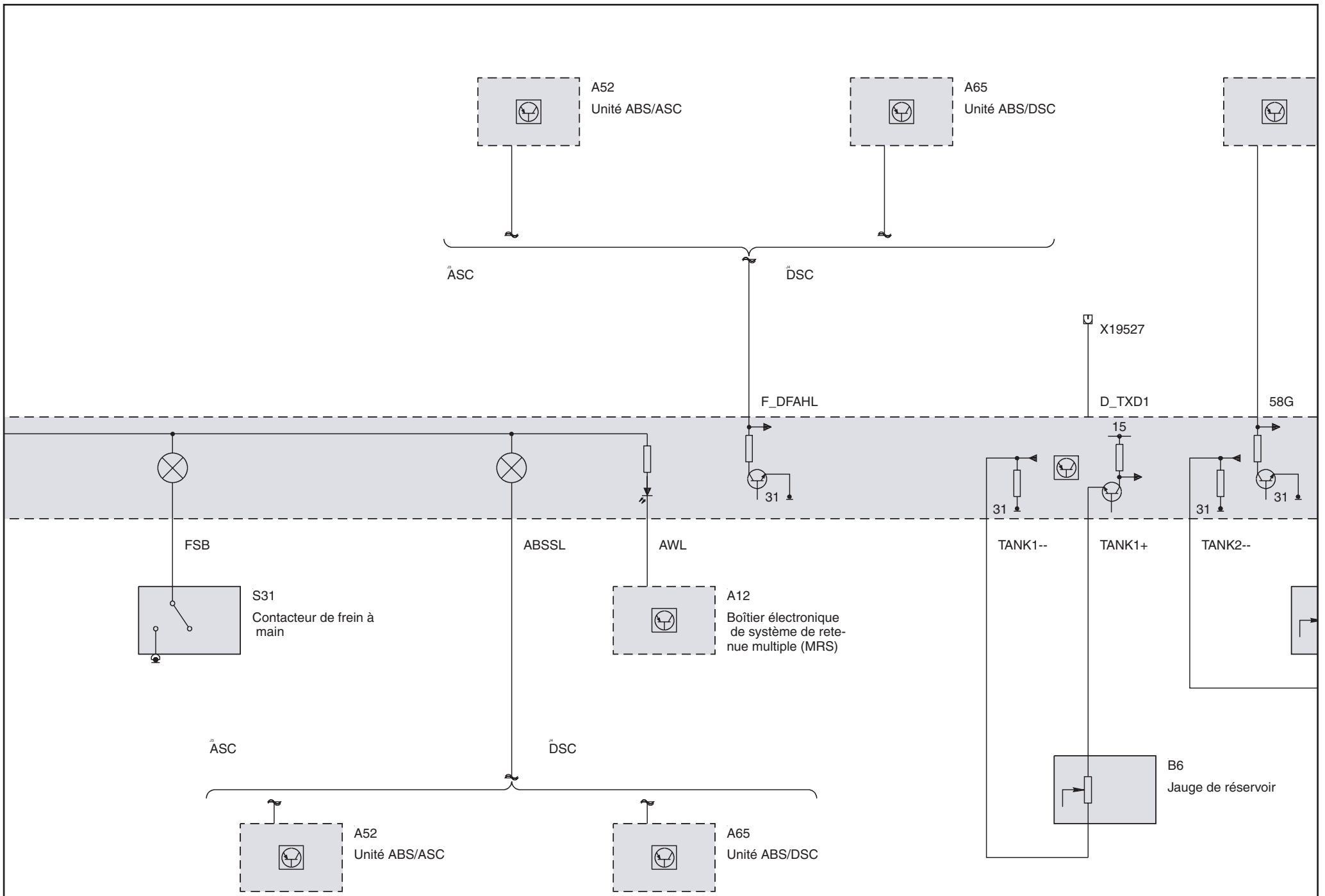

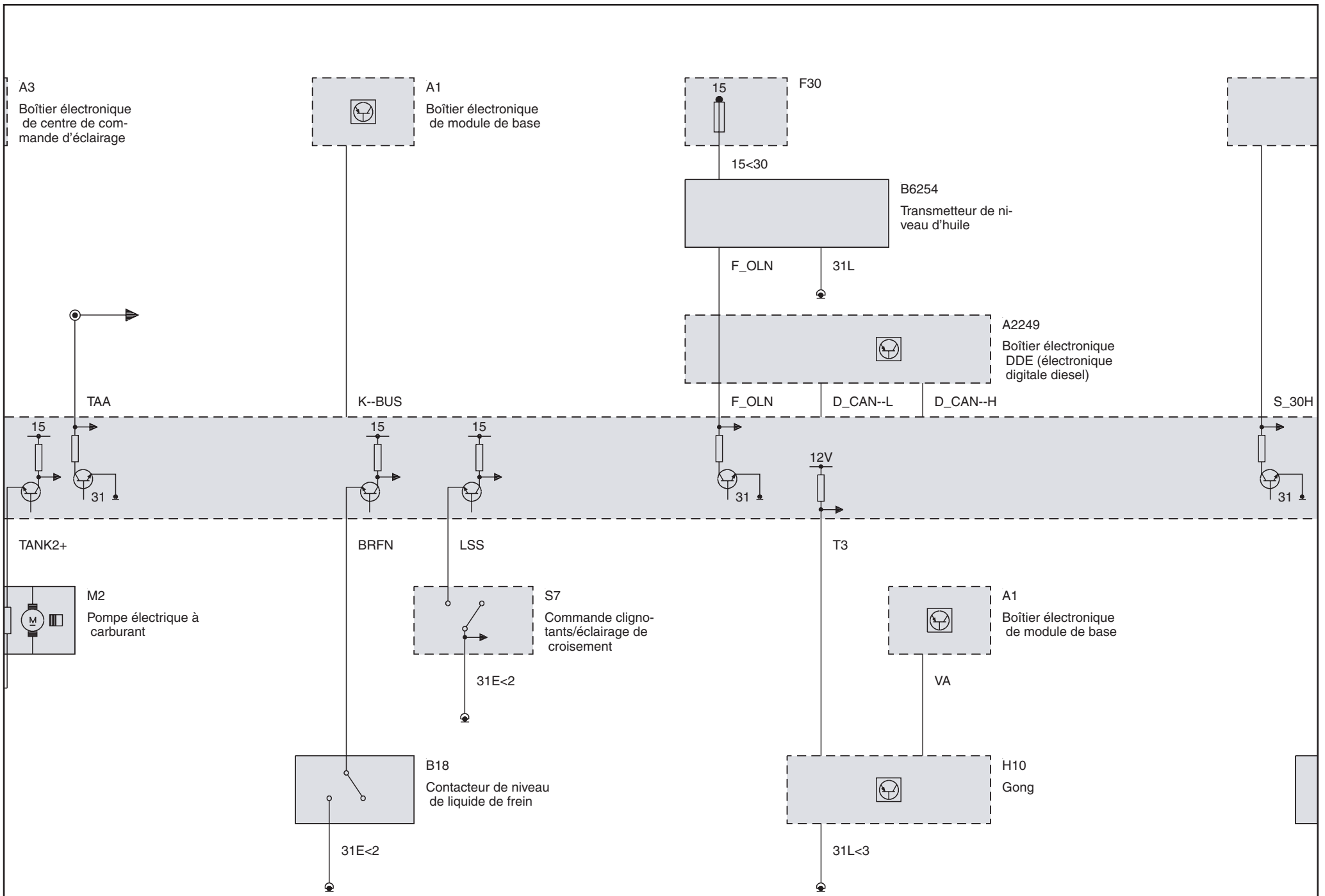

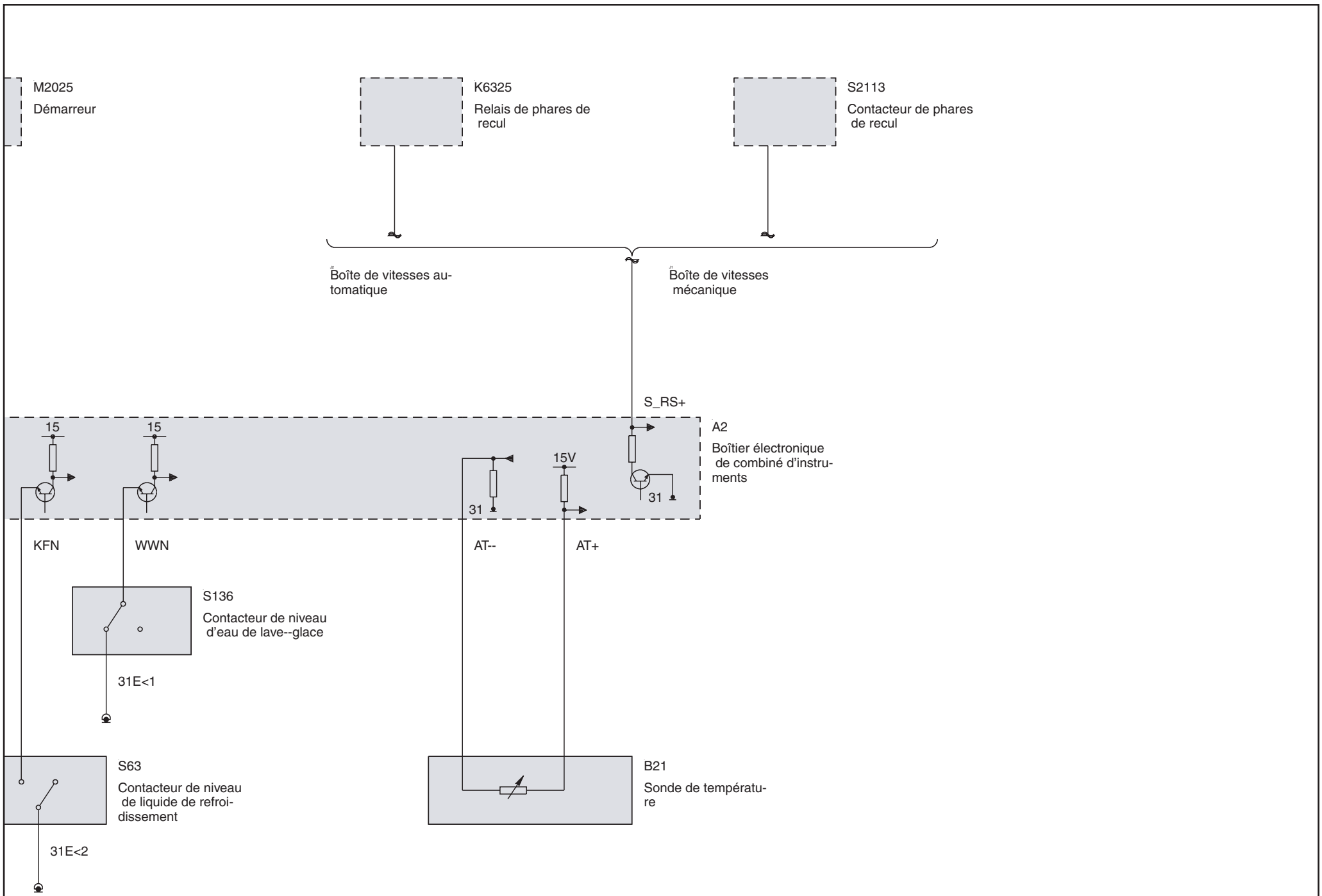



Fonctions d'affichage et d'information (DDE Electronique Diesel DDE50 avec ( ASC MK60 ou DSC MK60 ) à partir de 2002\_09)

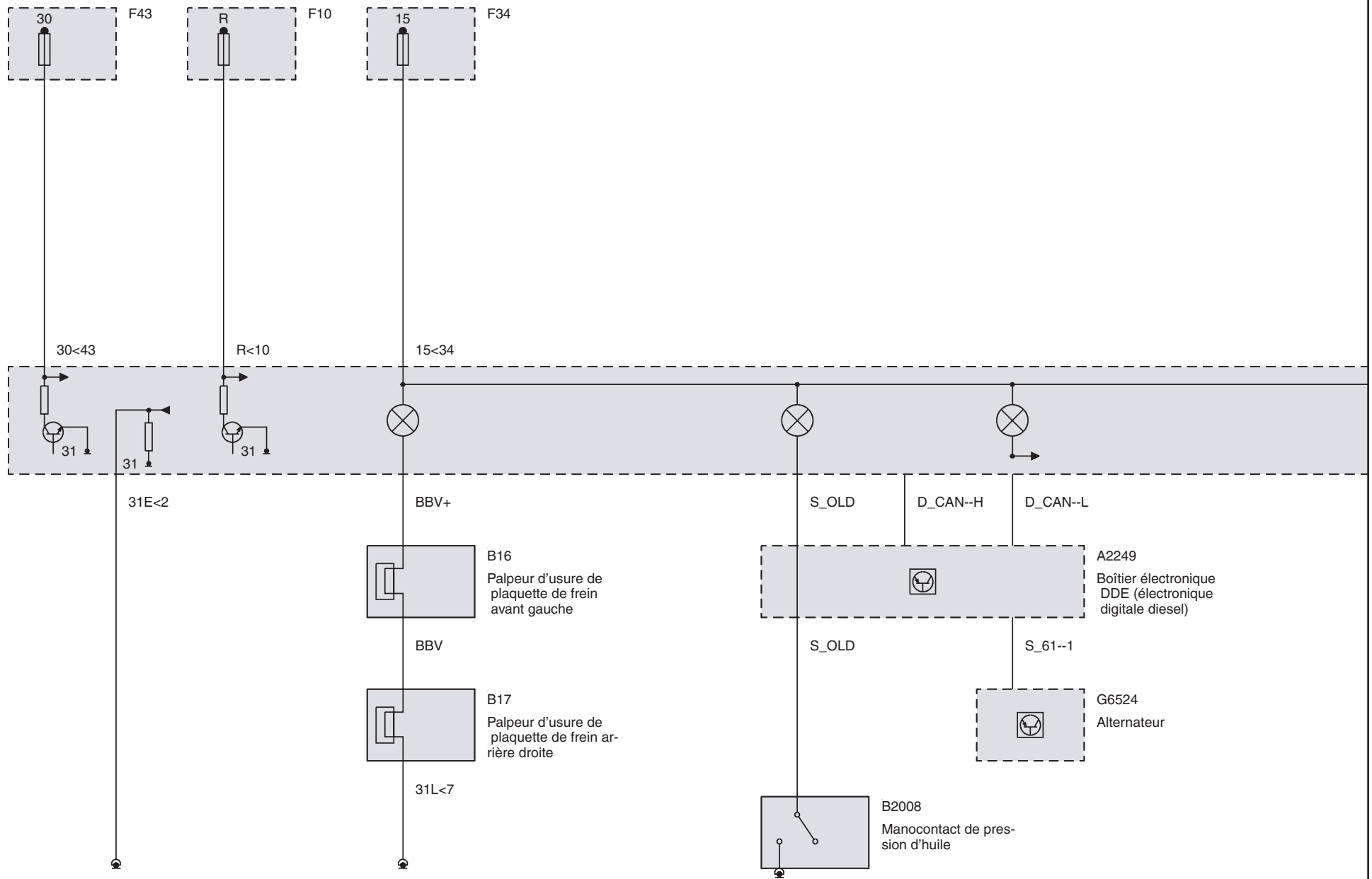

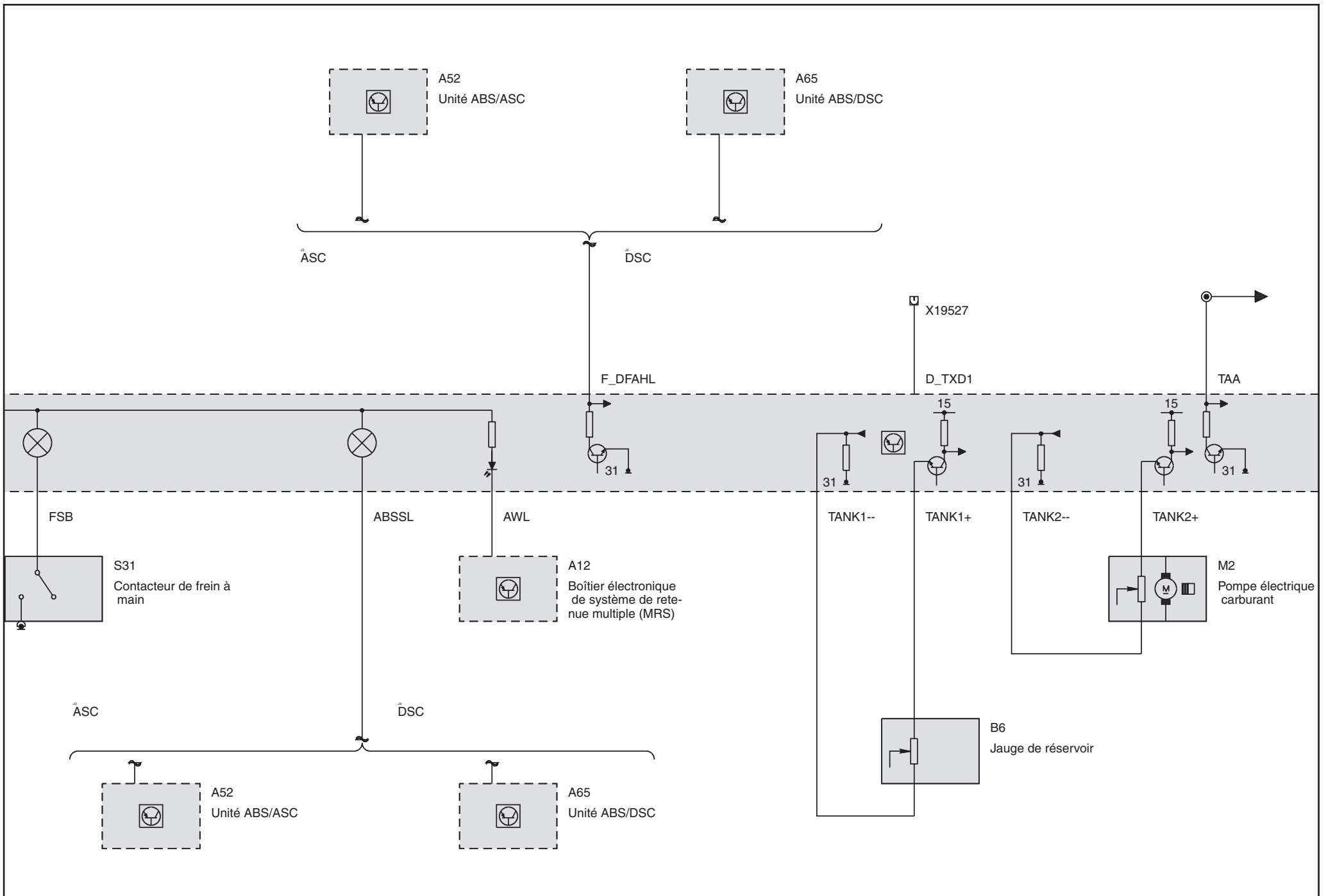

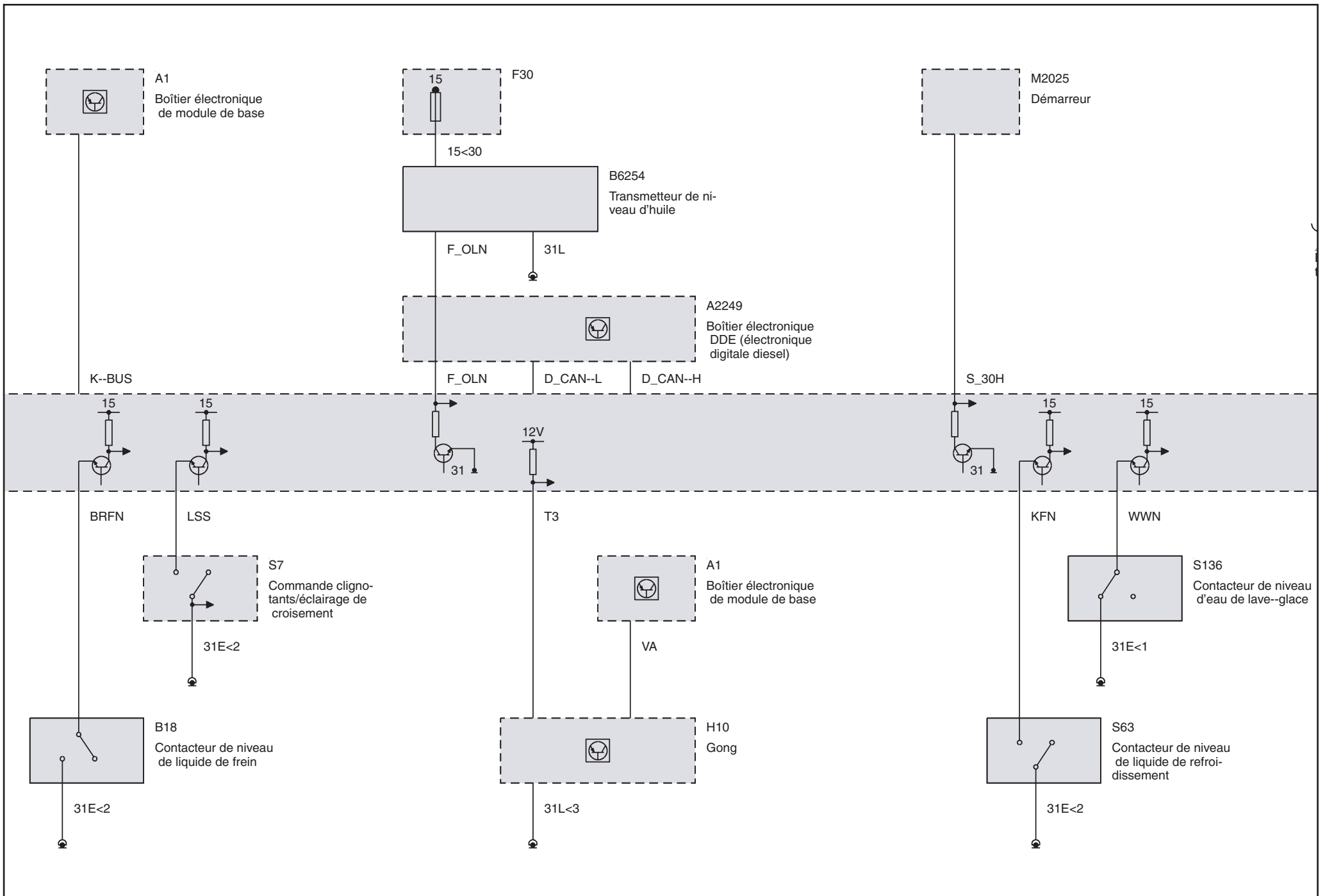

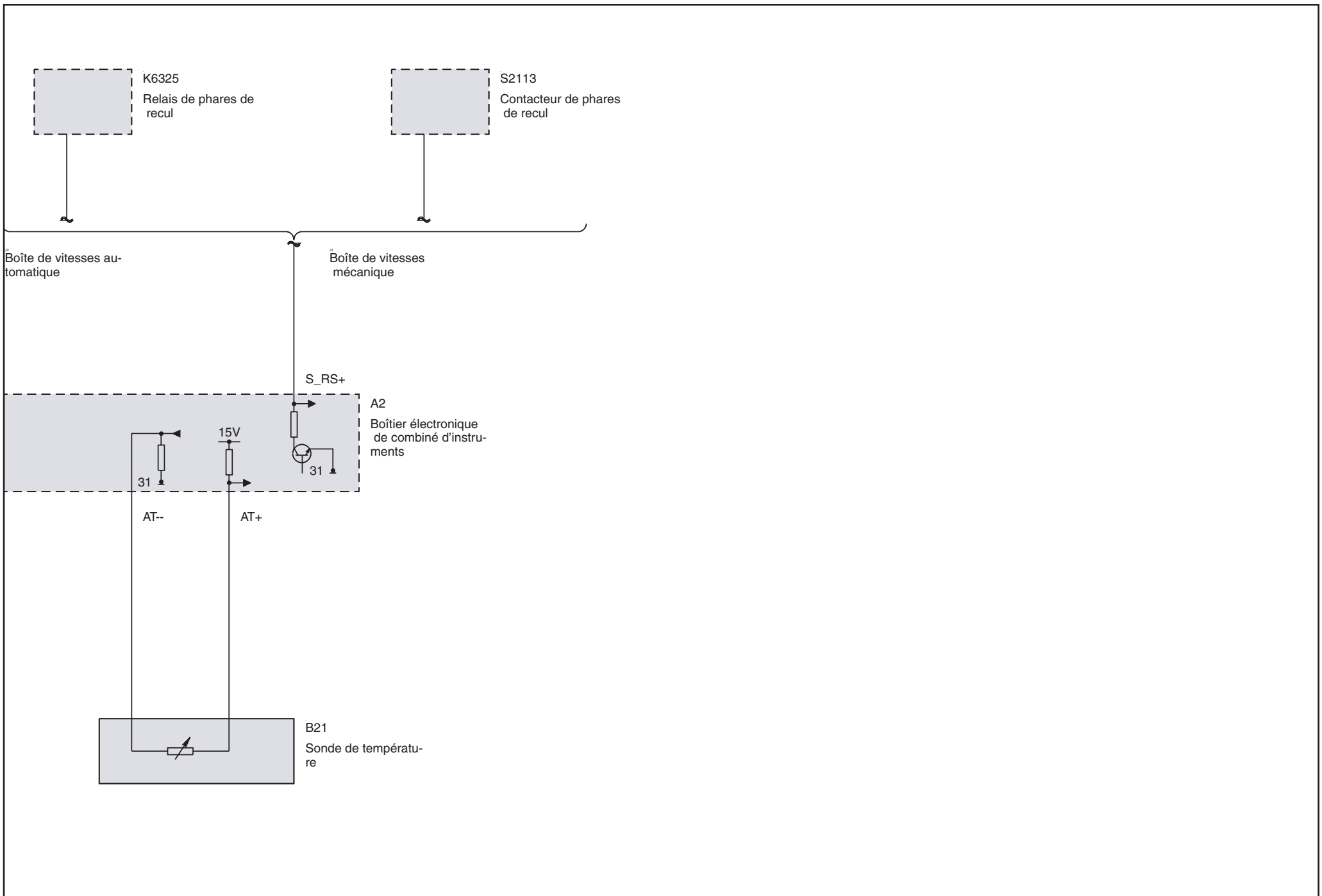

Fonctions d'affichage et d'information (DME Electronique moteur MS43 avec ( ASC MK60 ou DSC MK60 ou Transmission intégrale ) jusque 2002\_09)

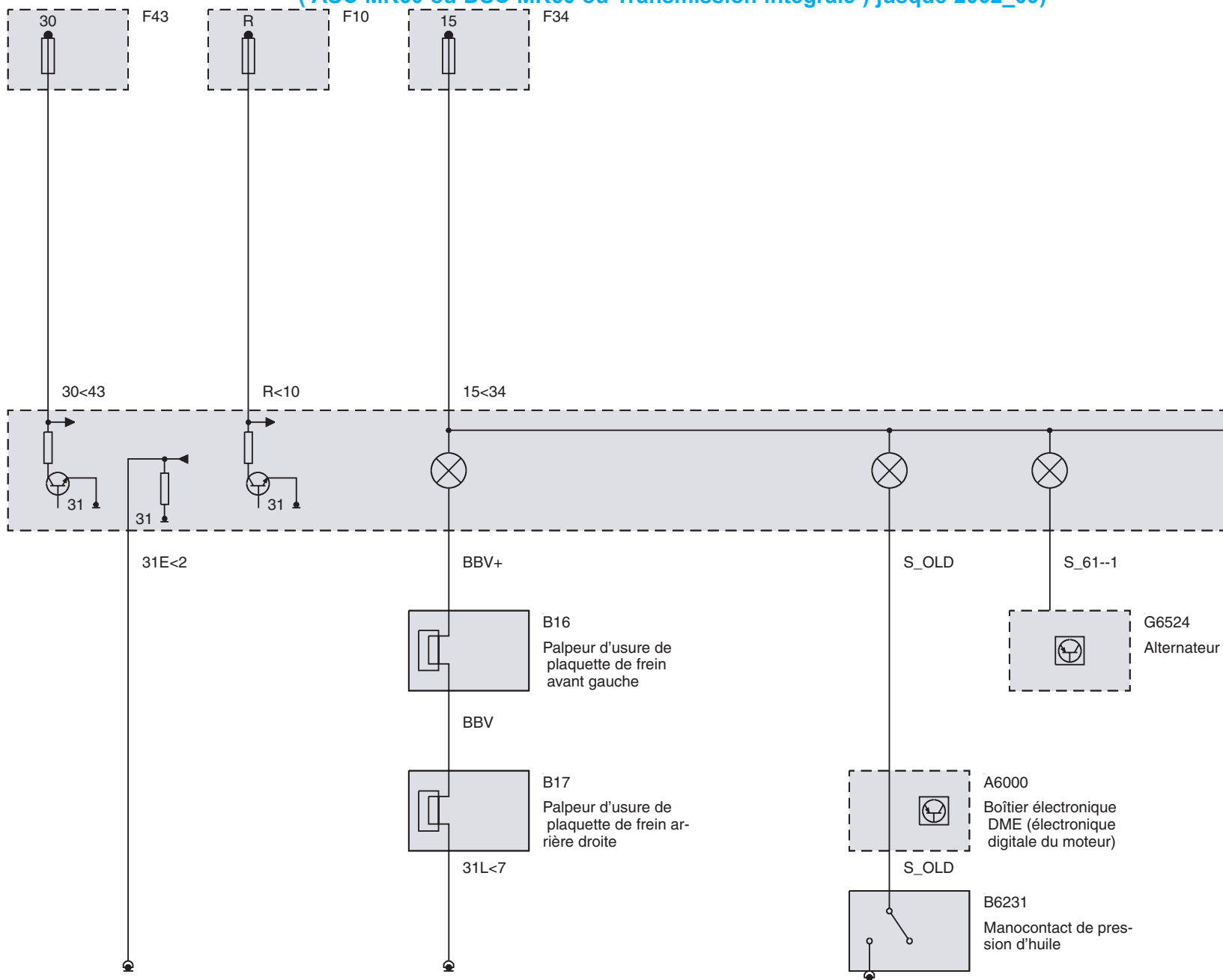

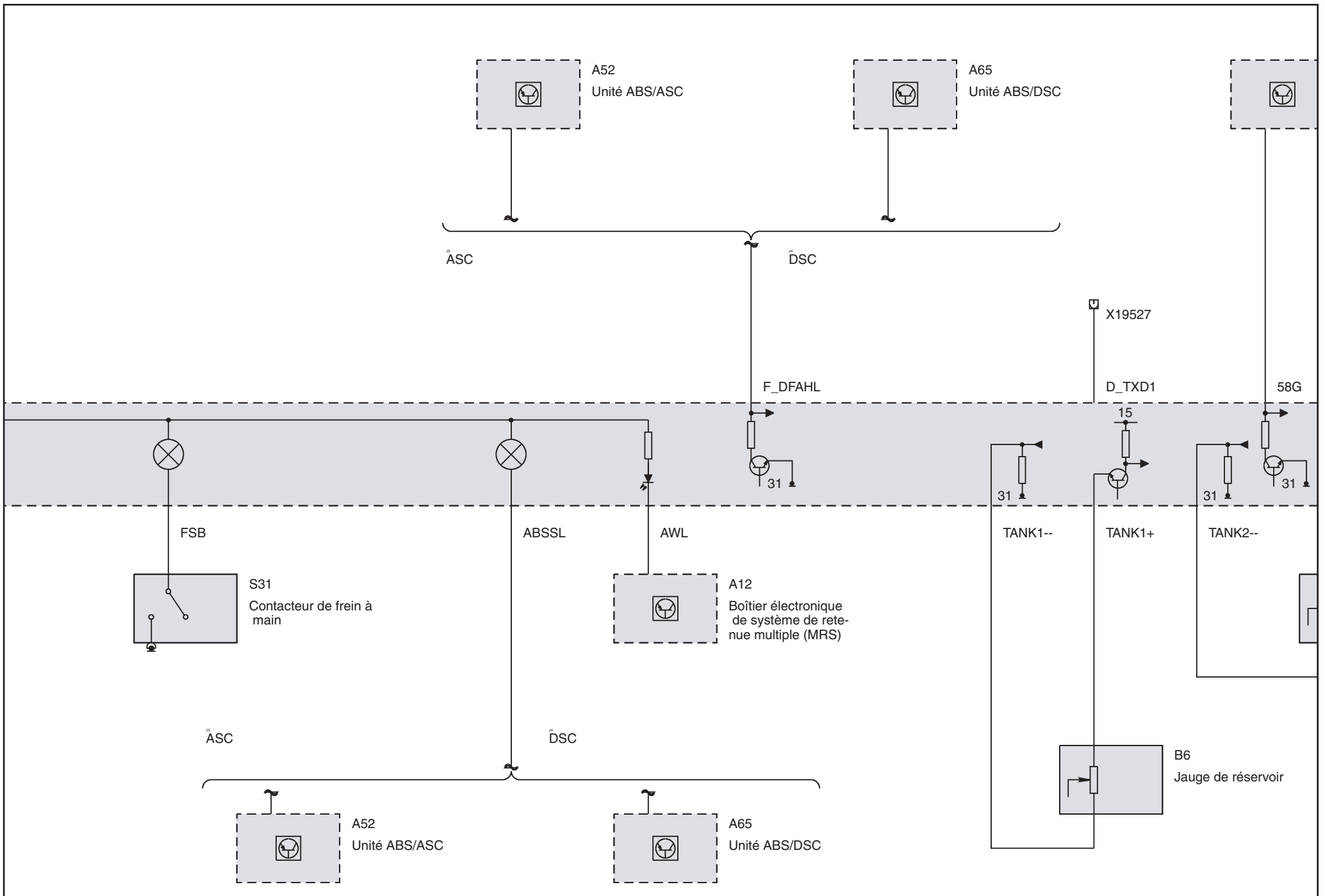

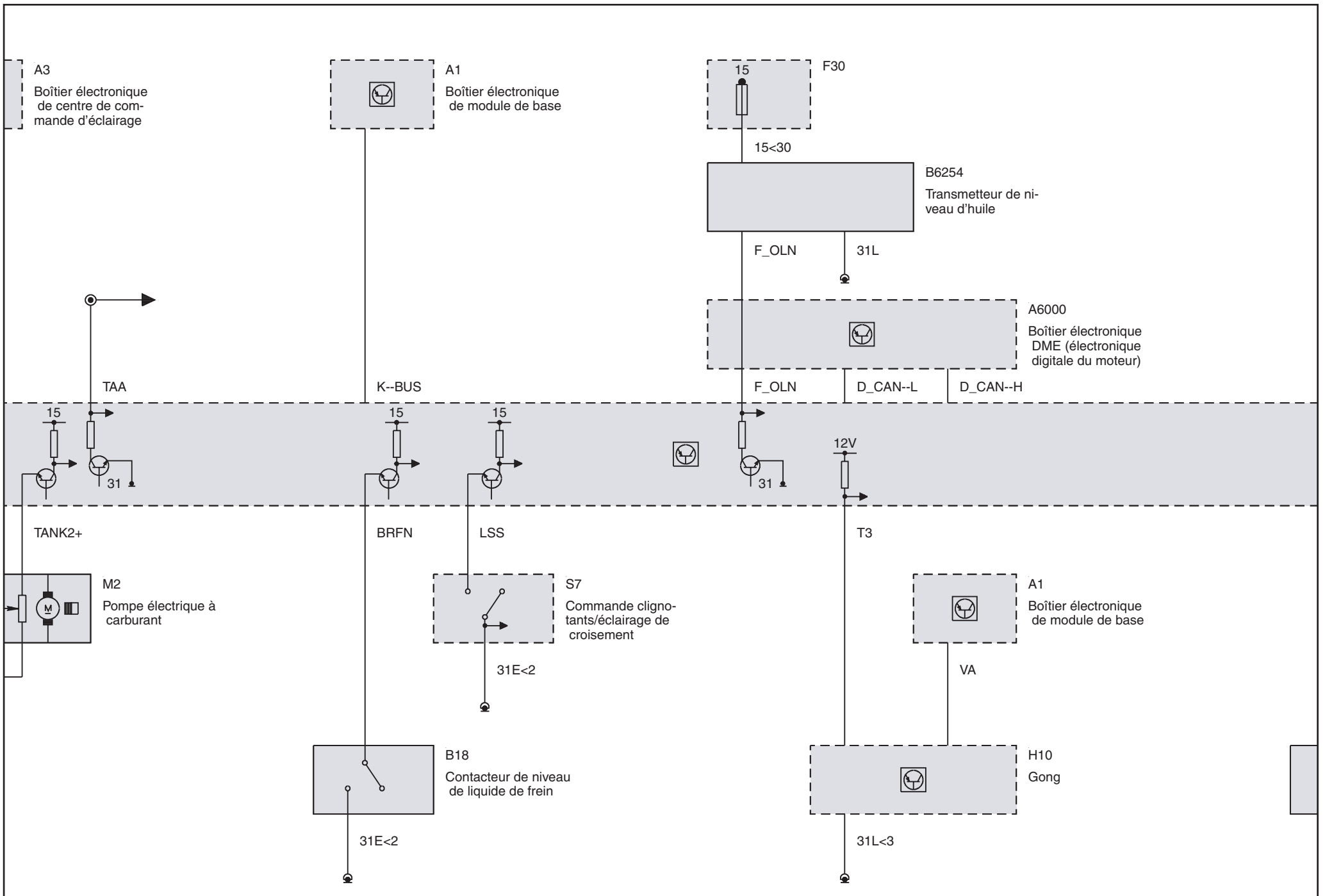

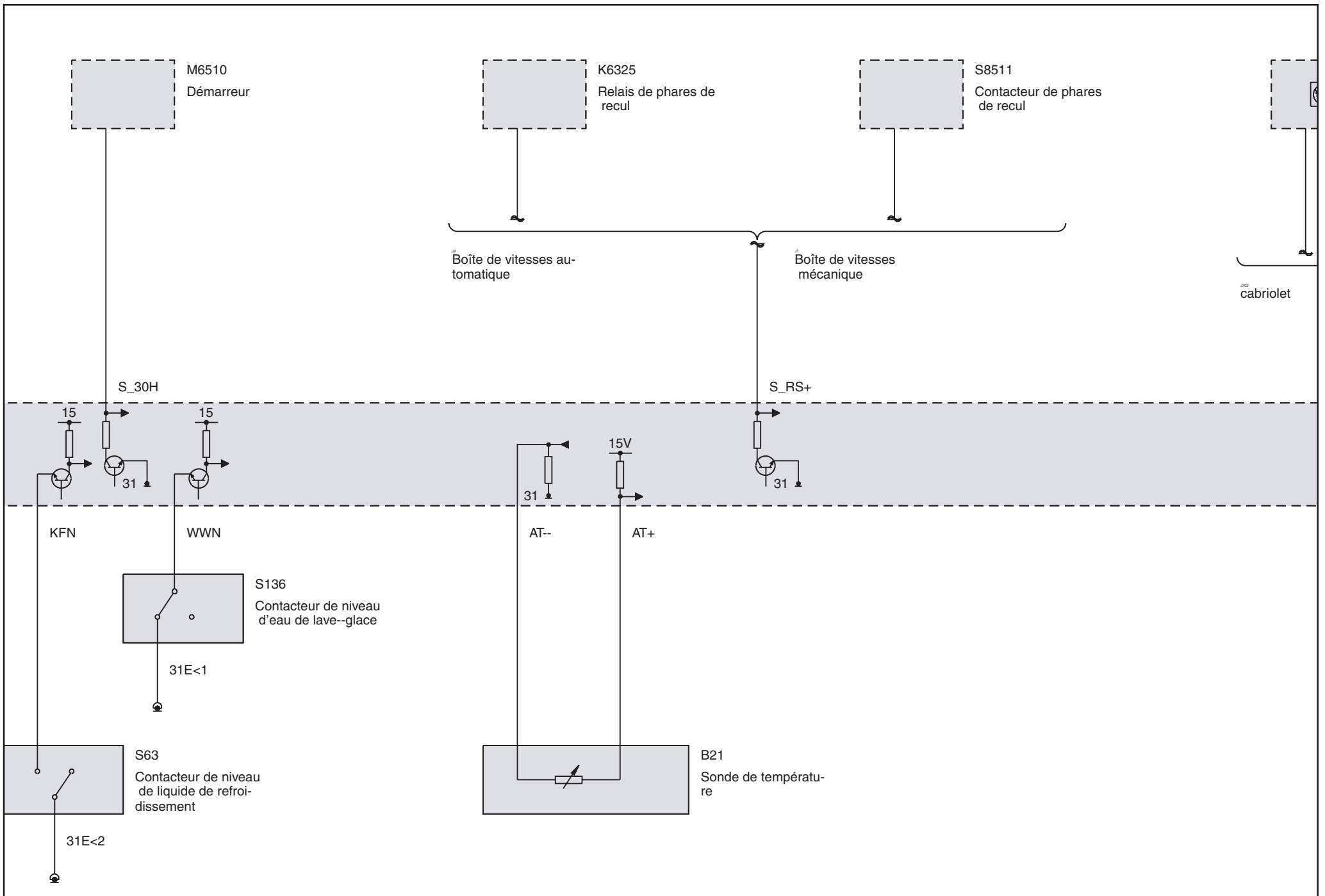



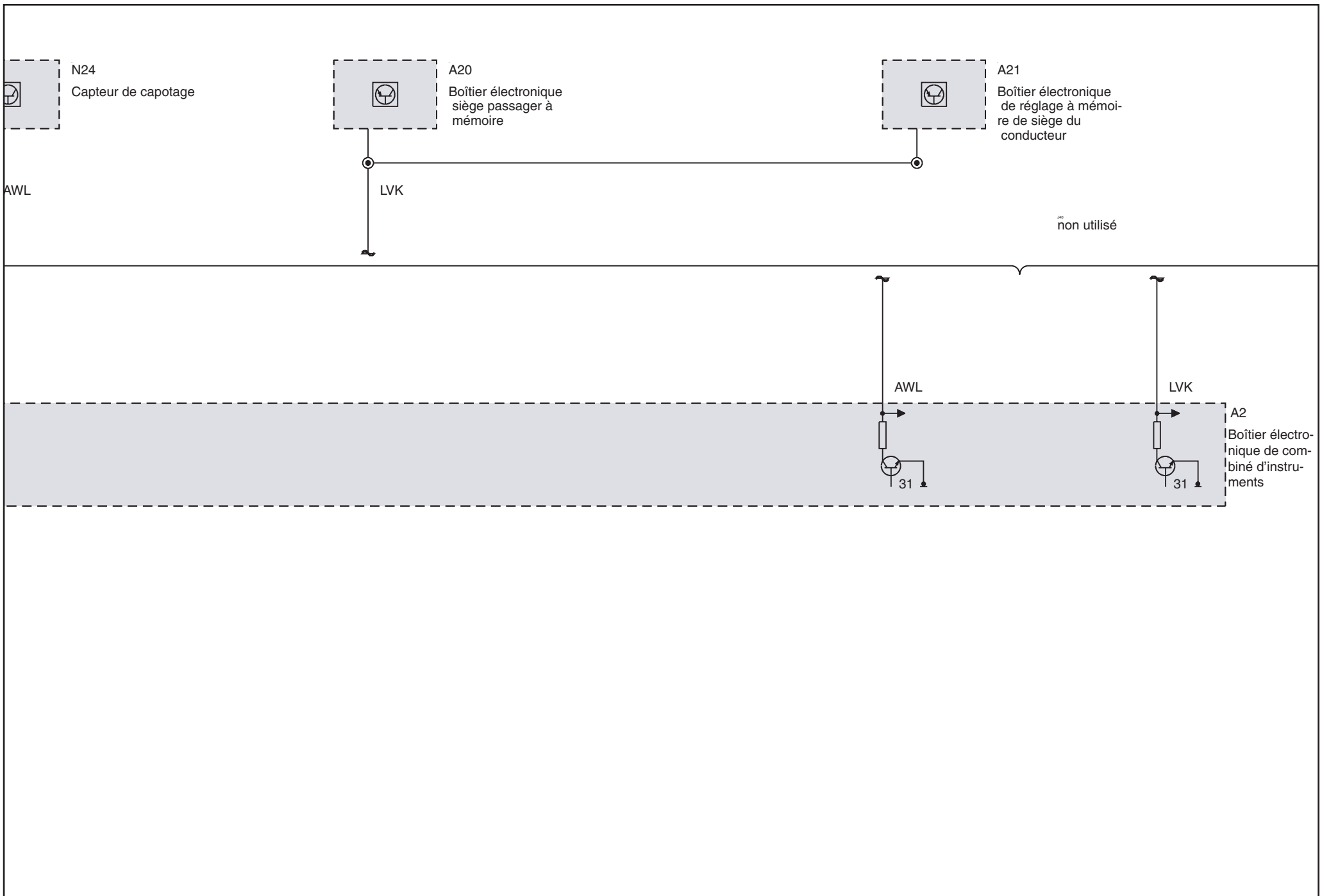

Fonctions d'affichage et d'information (DME Electronique moteur MS43 avec ( ASC MK60 ou DSC MK60 ou Transmission intégrale ) à partir de 2002\_09)

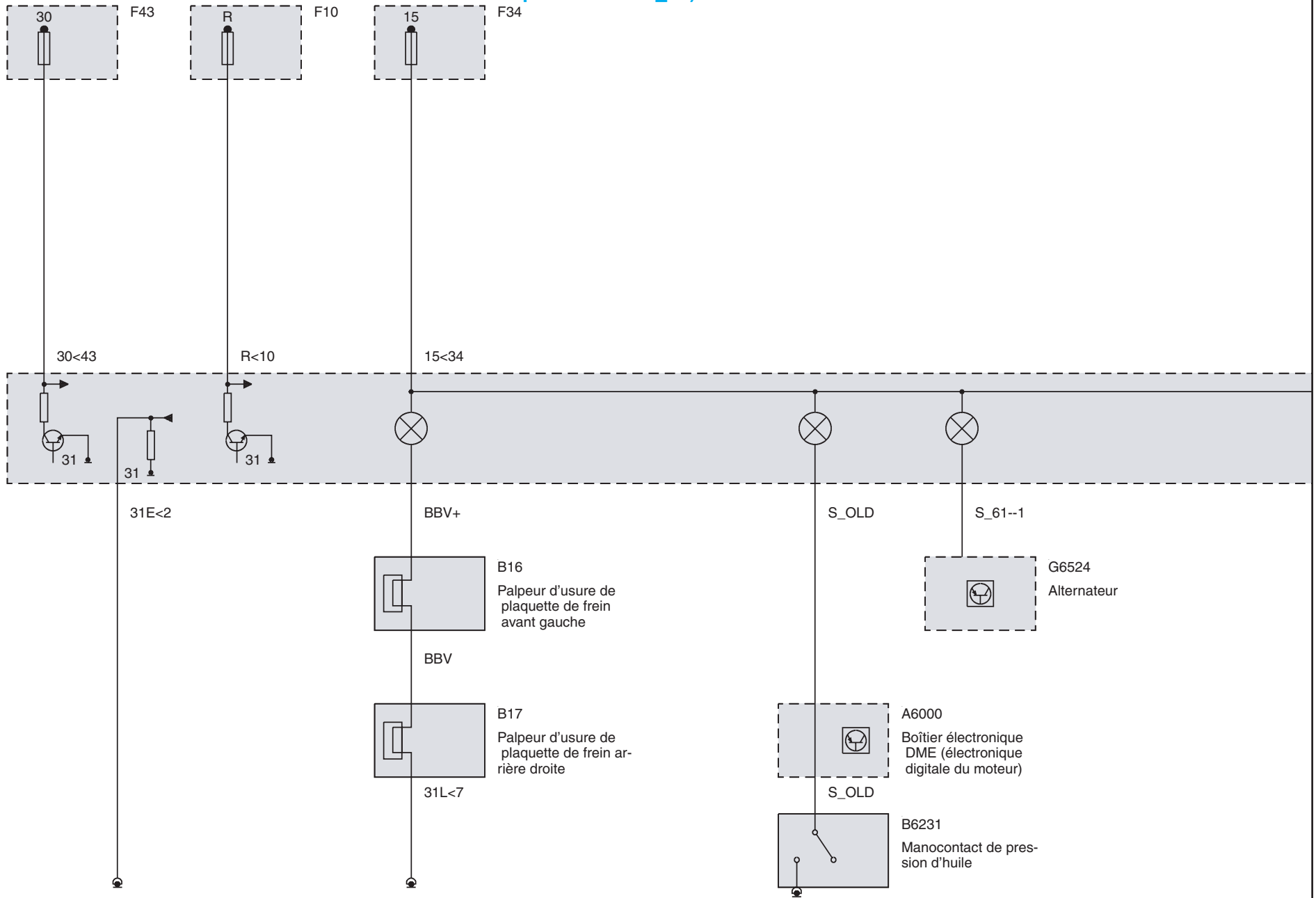

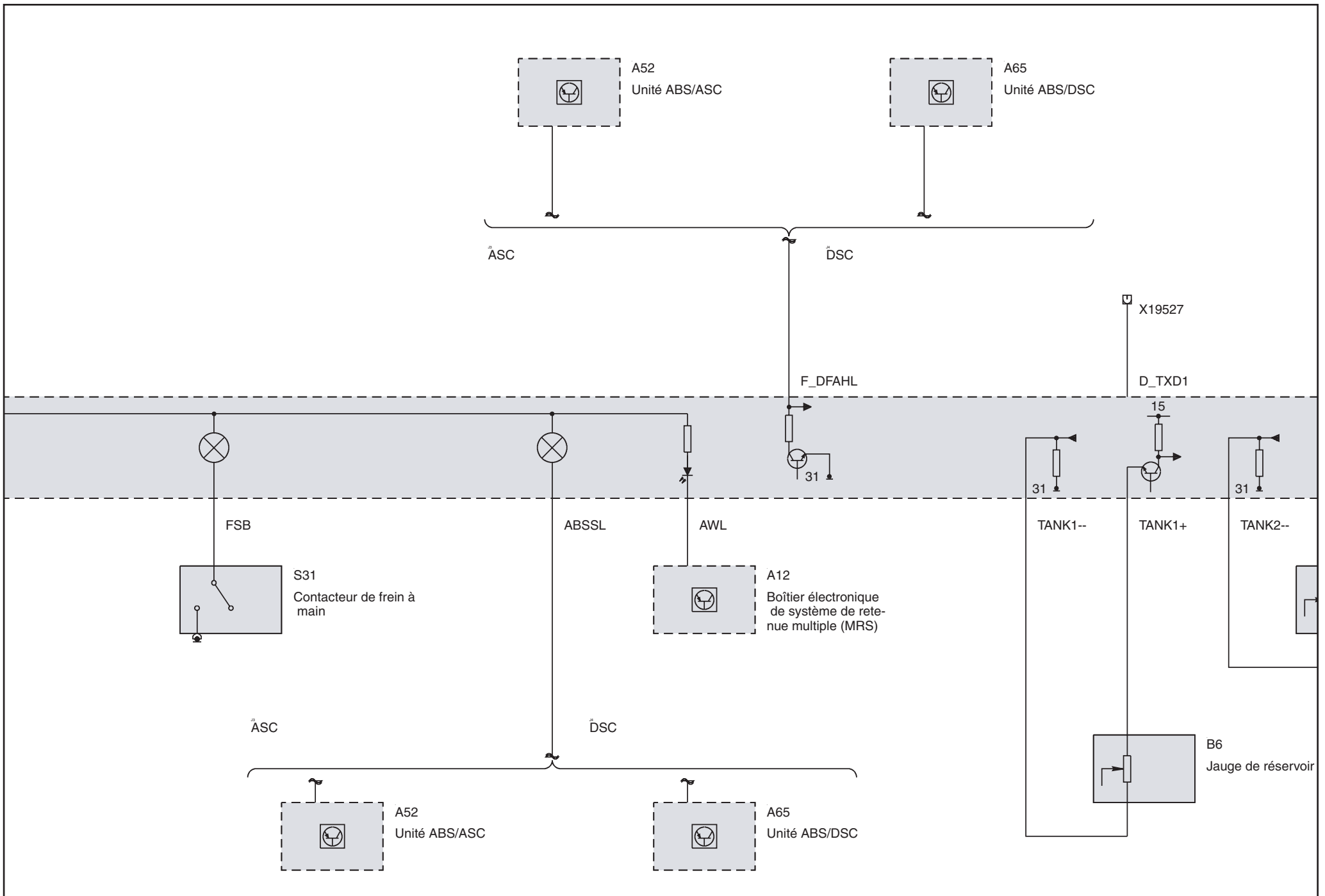

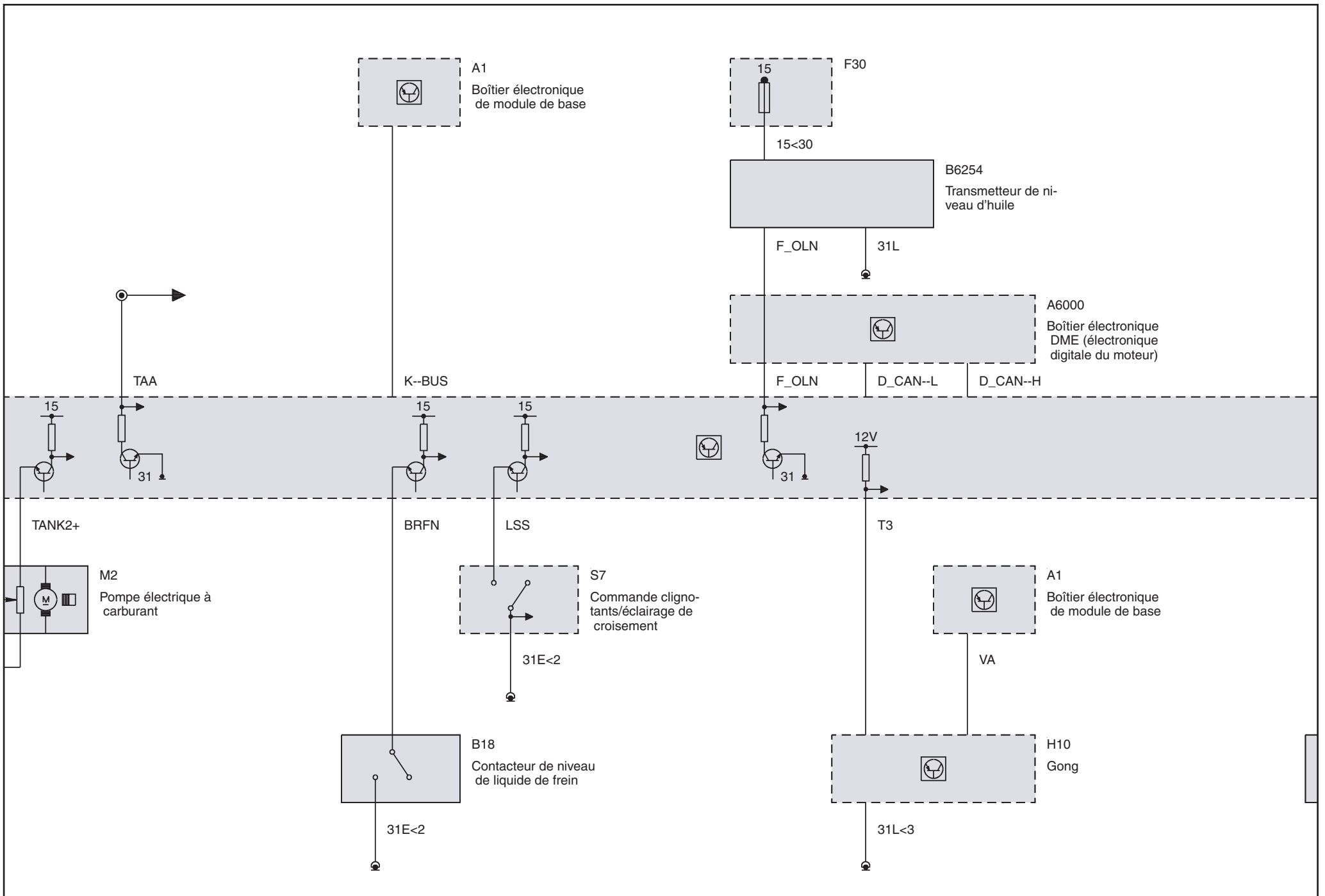

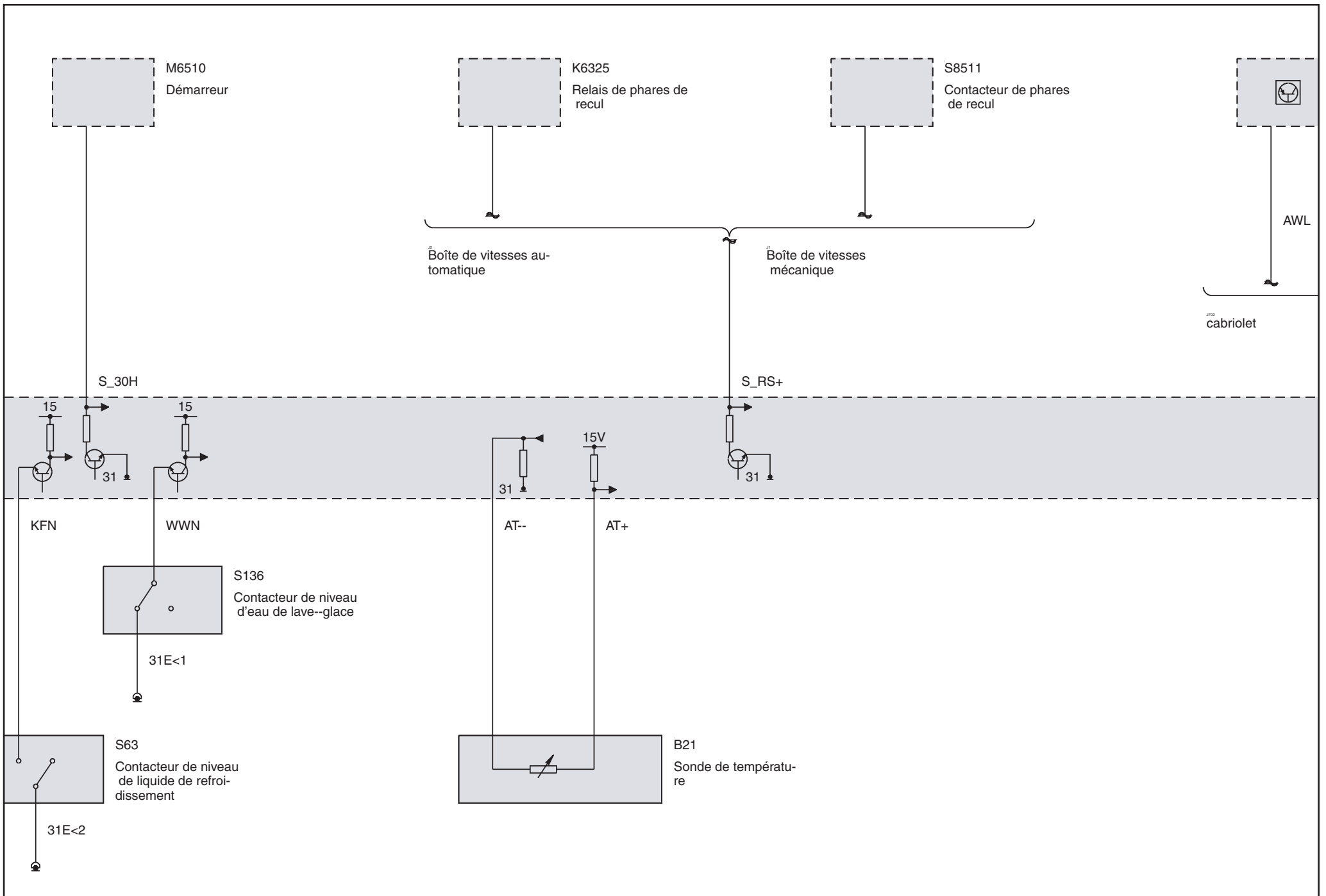

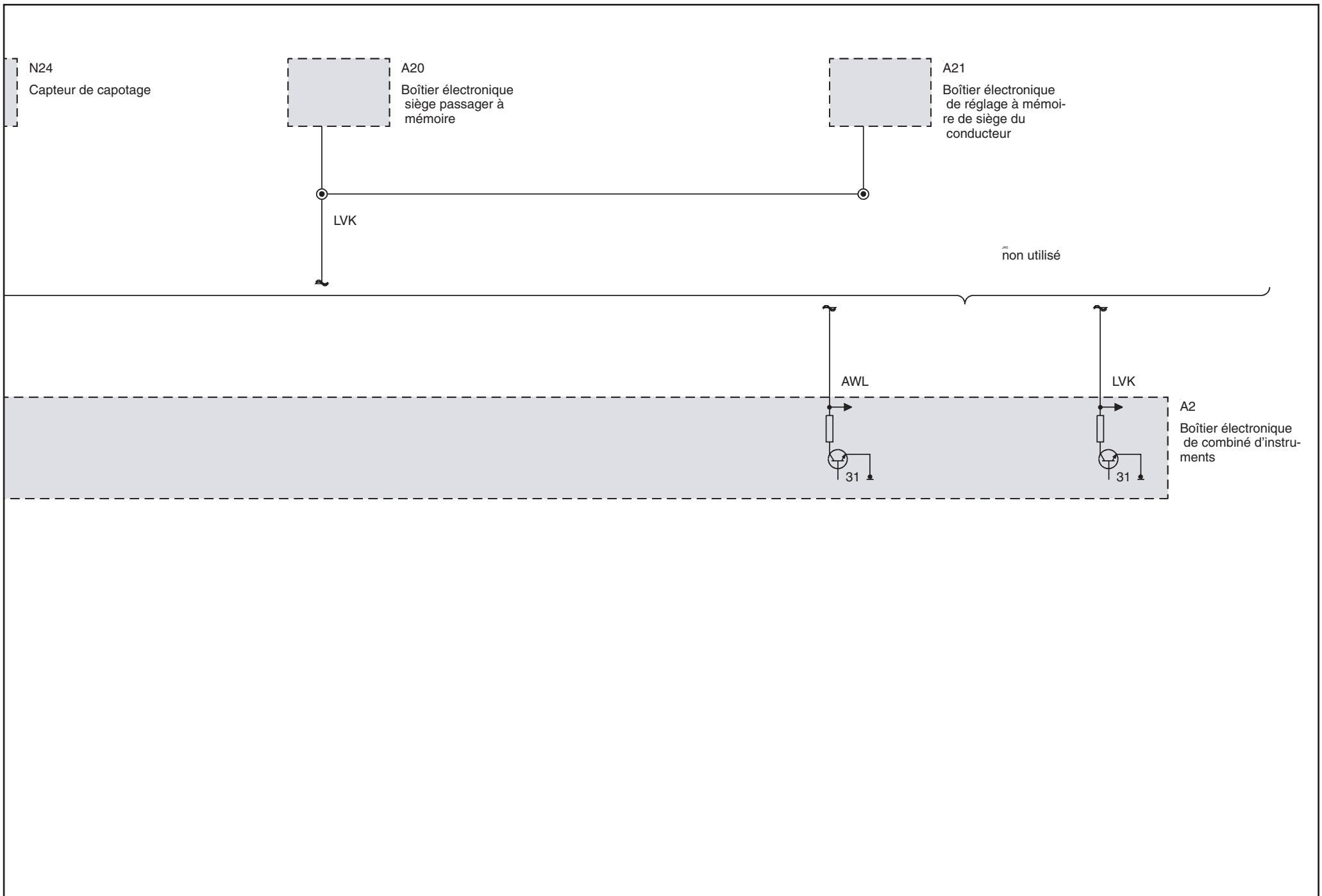

Fonctions d'affichage et d'information (DME Electronique moteur ME9 avec ( ASC MK60 ou DSC MK60 ) jusque 2002\_09)

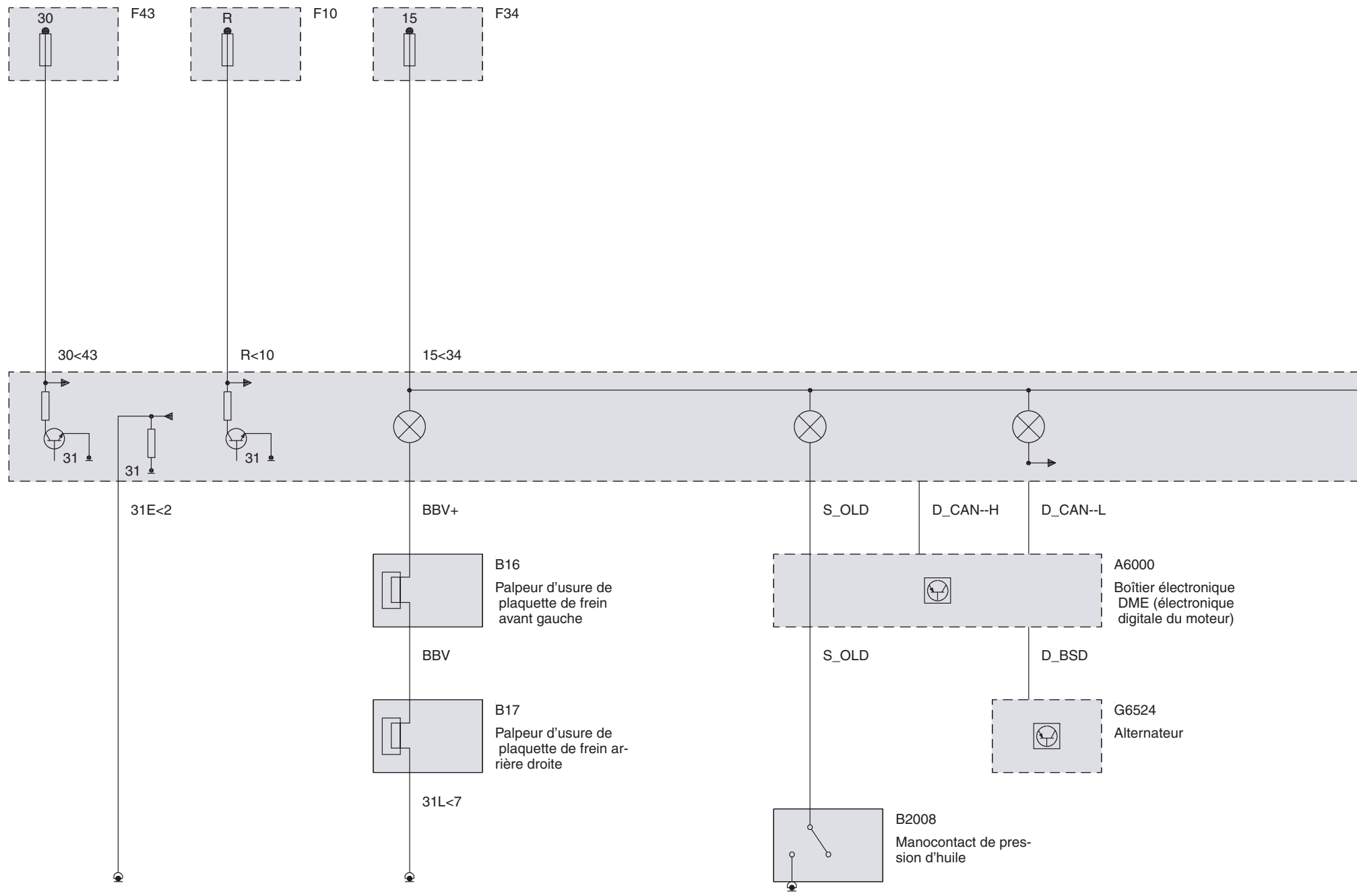

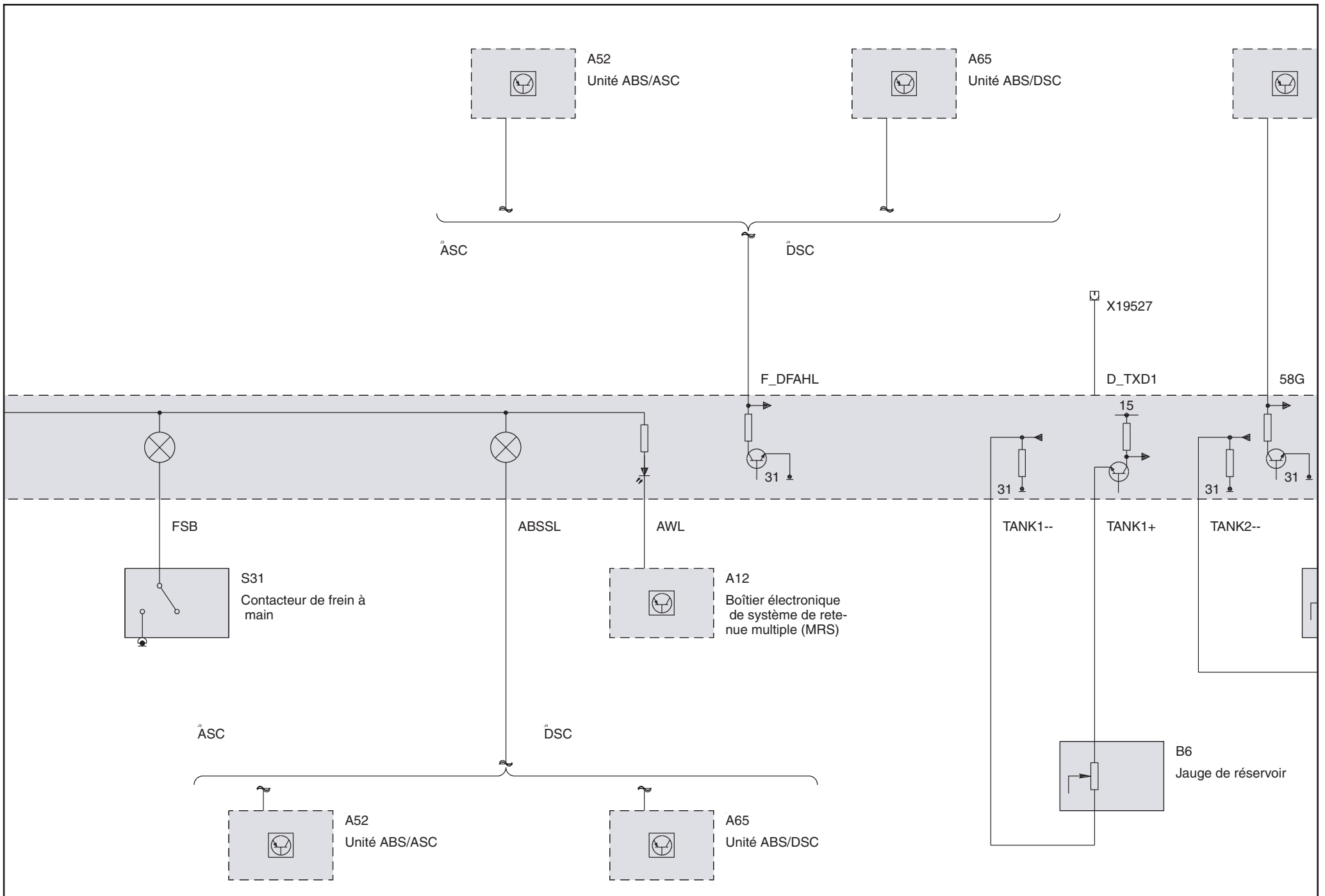



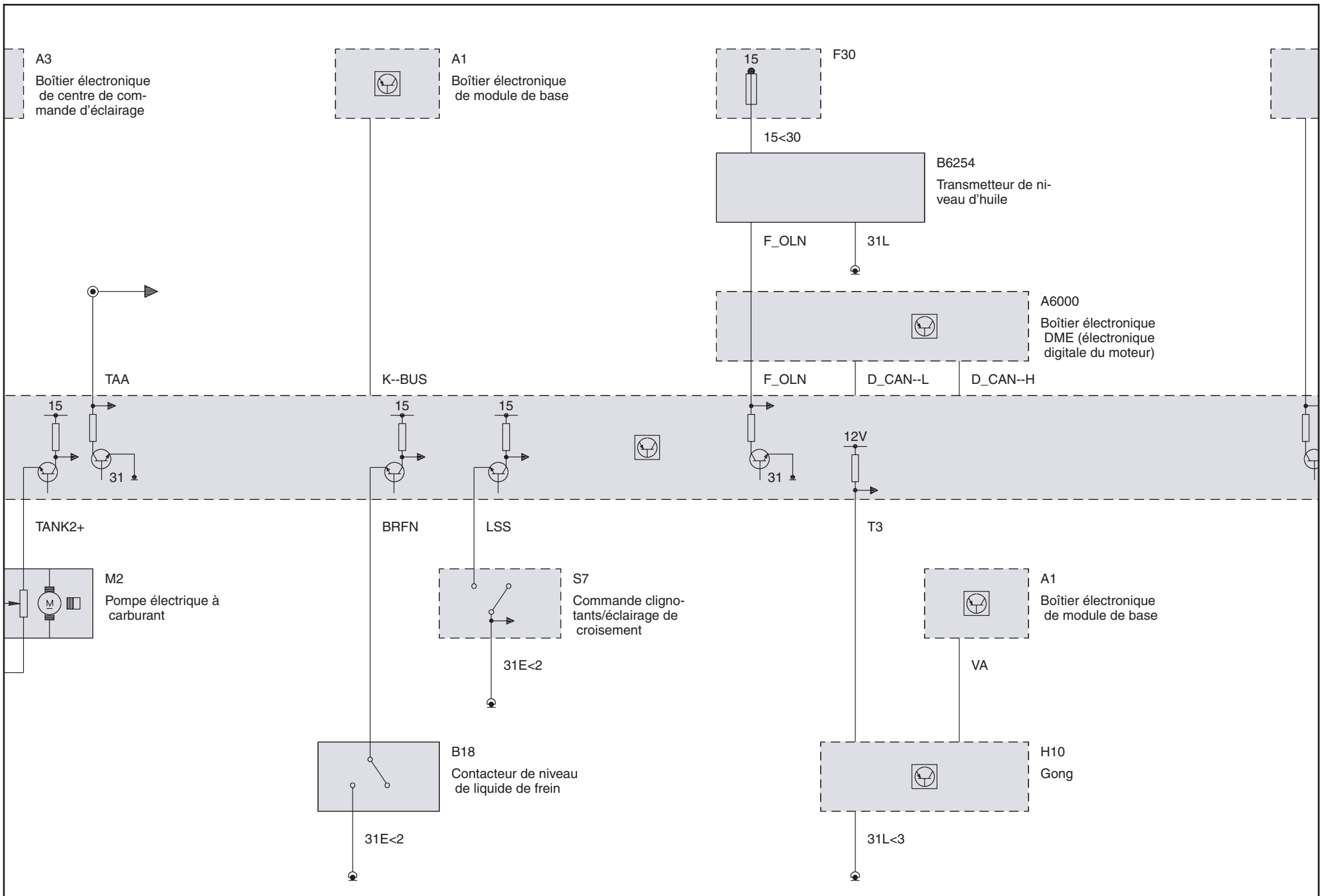

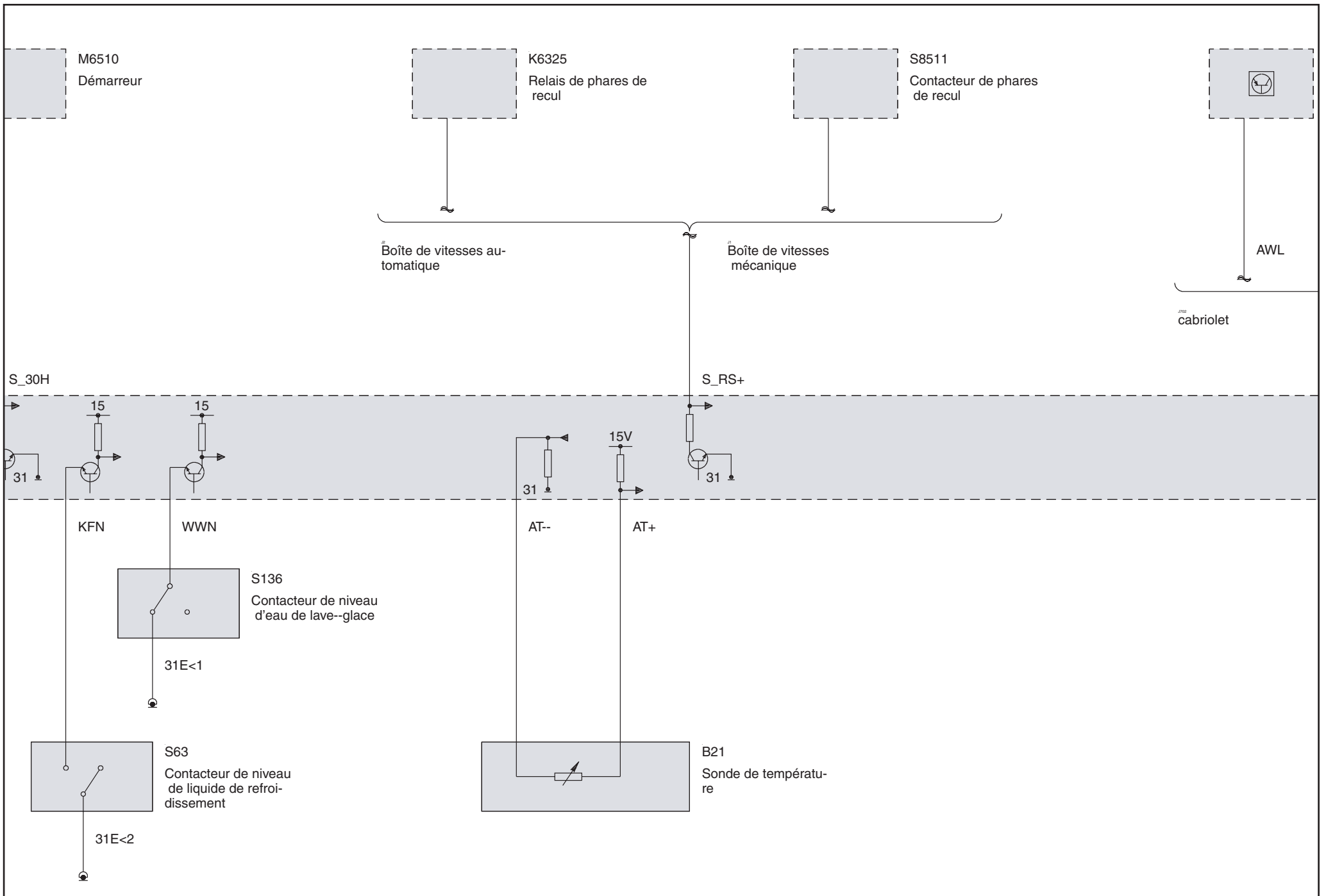

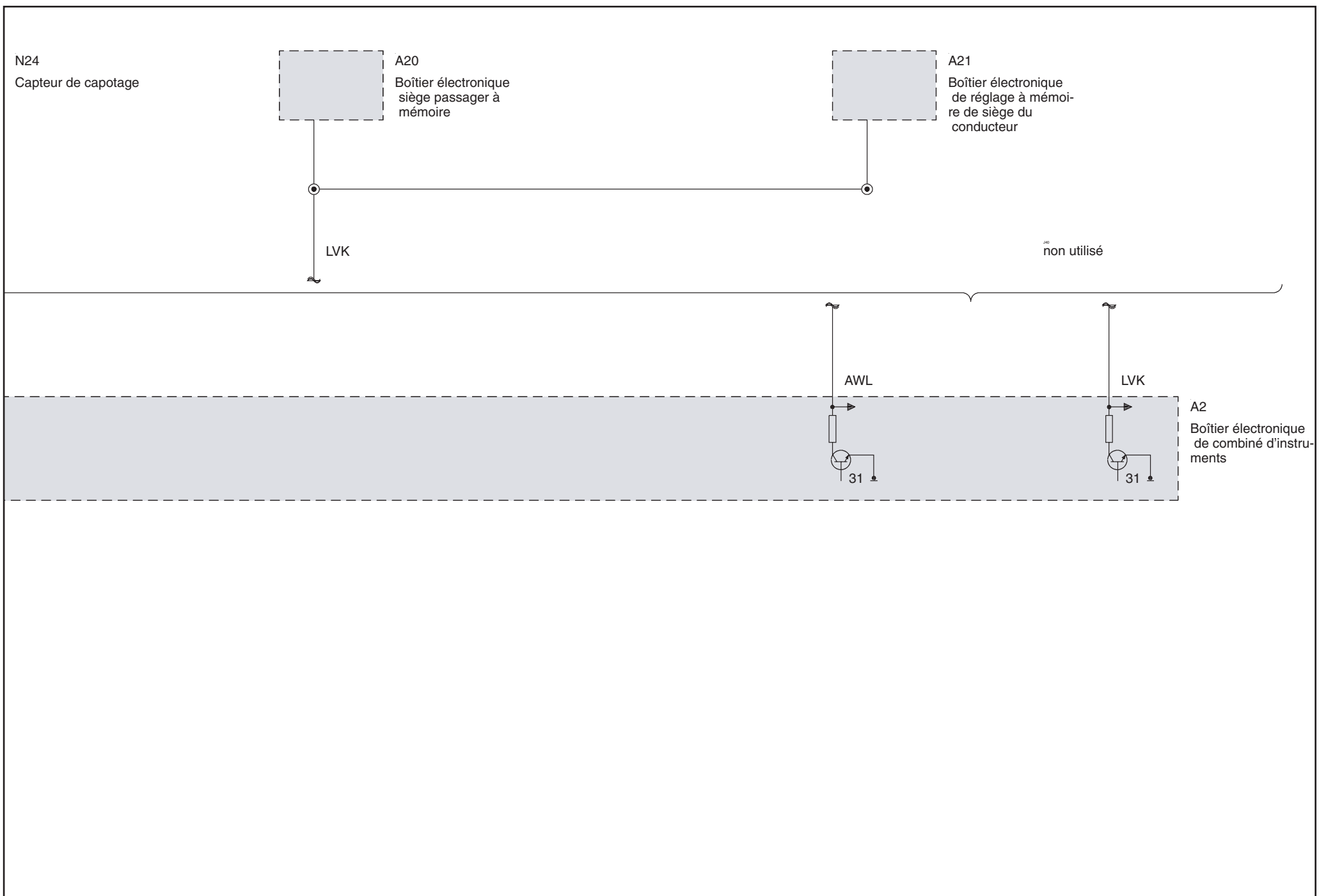

Fonctions d'affichage et d'information (DME Electronique moteur ME9 avec ( ASC MK60 ou DSC MK60 ) à partir de 2002\_09)

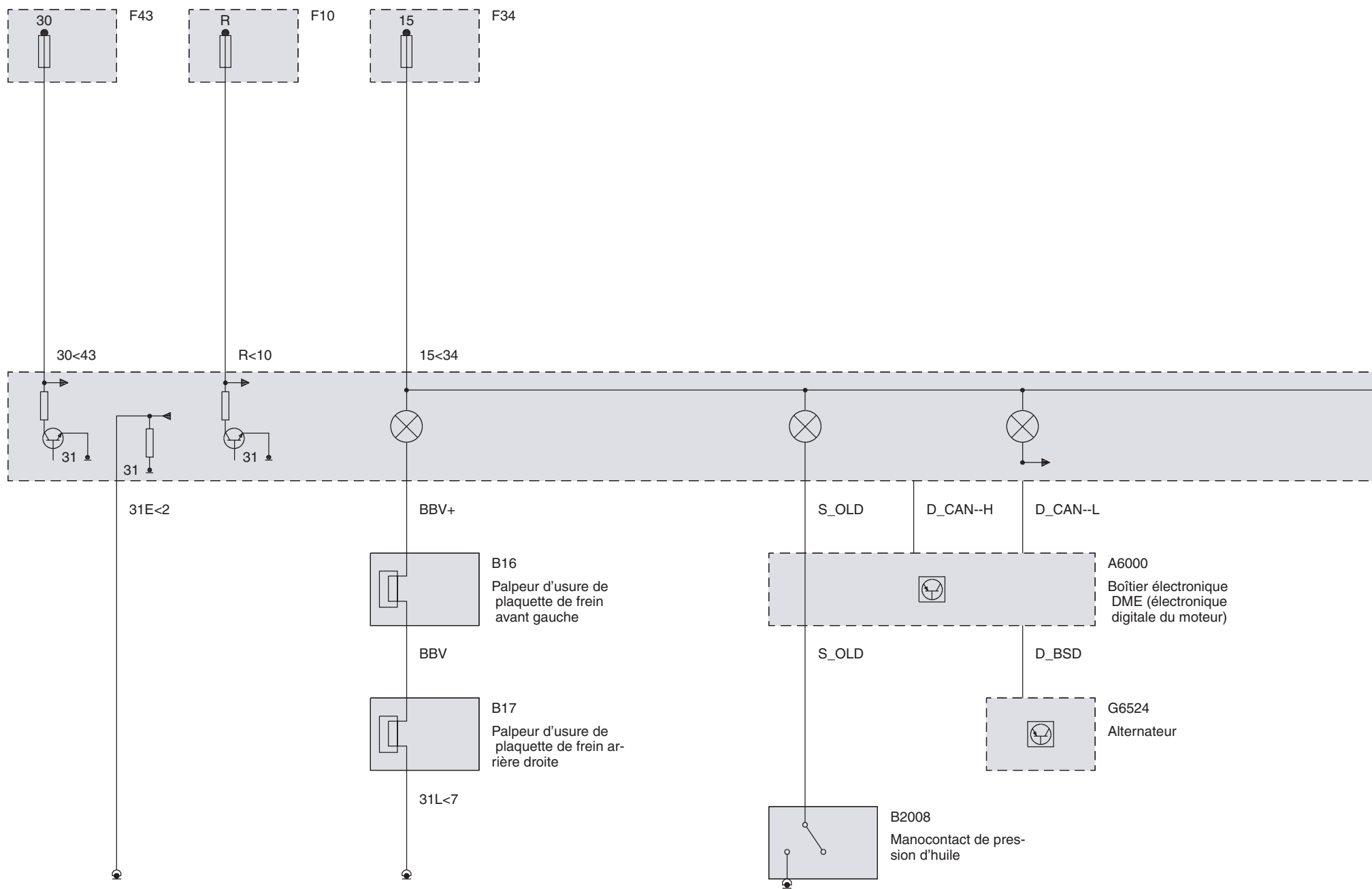

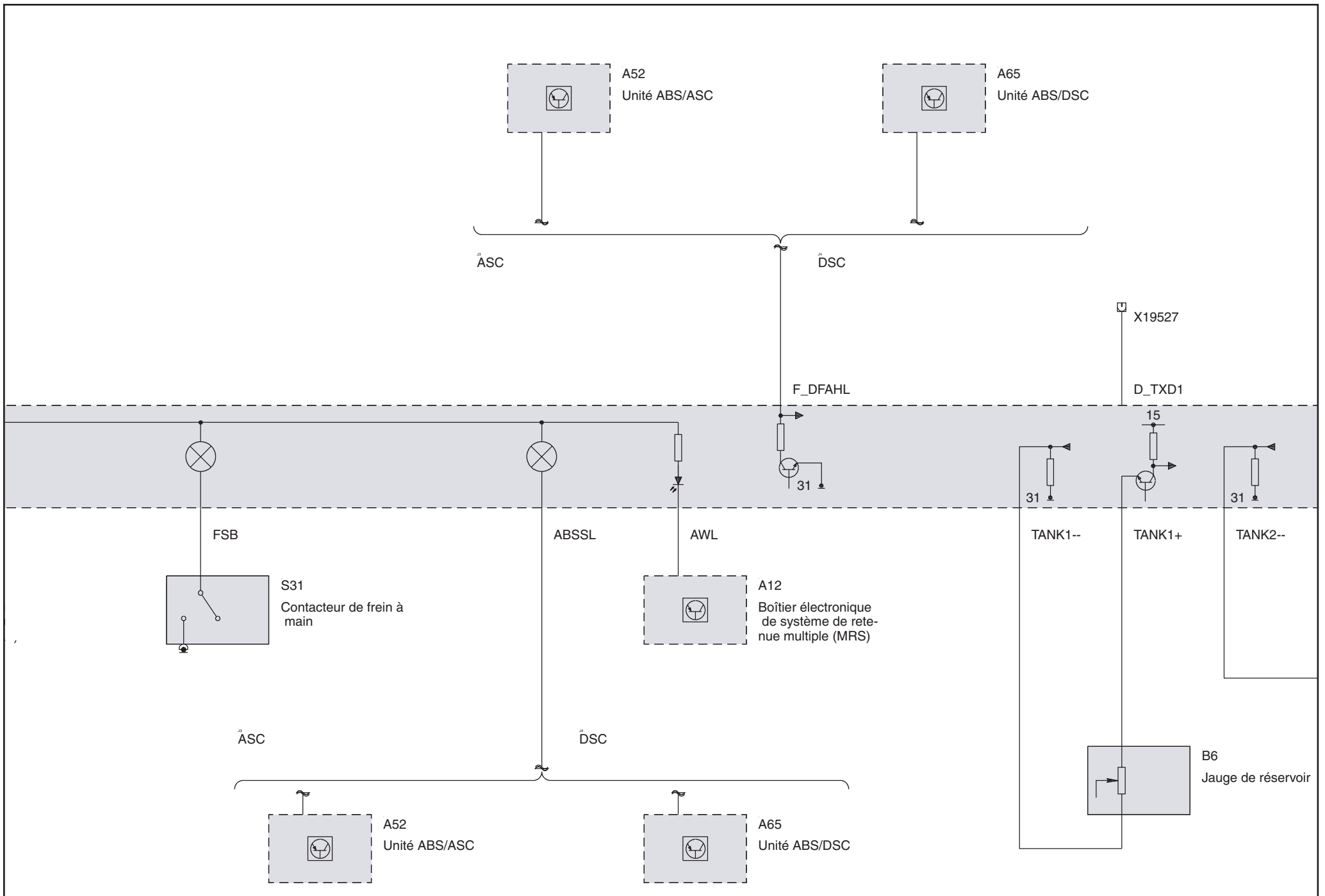

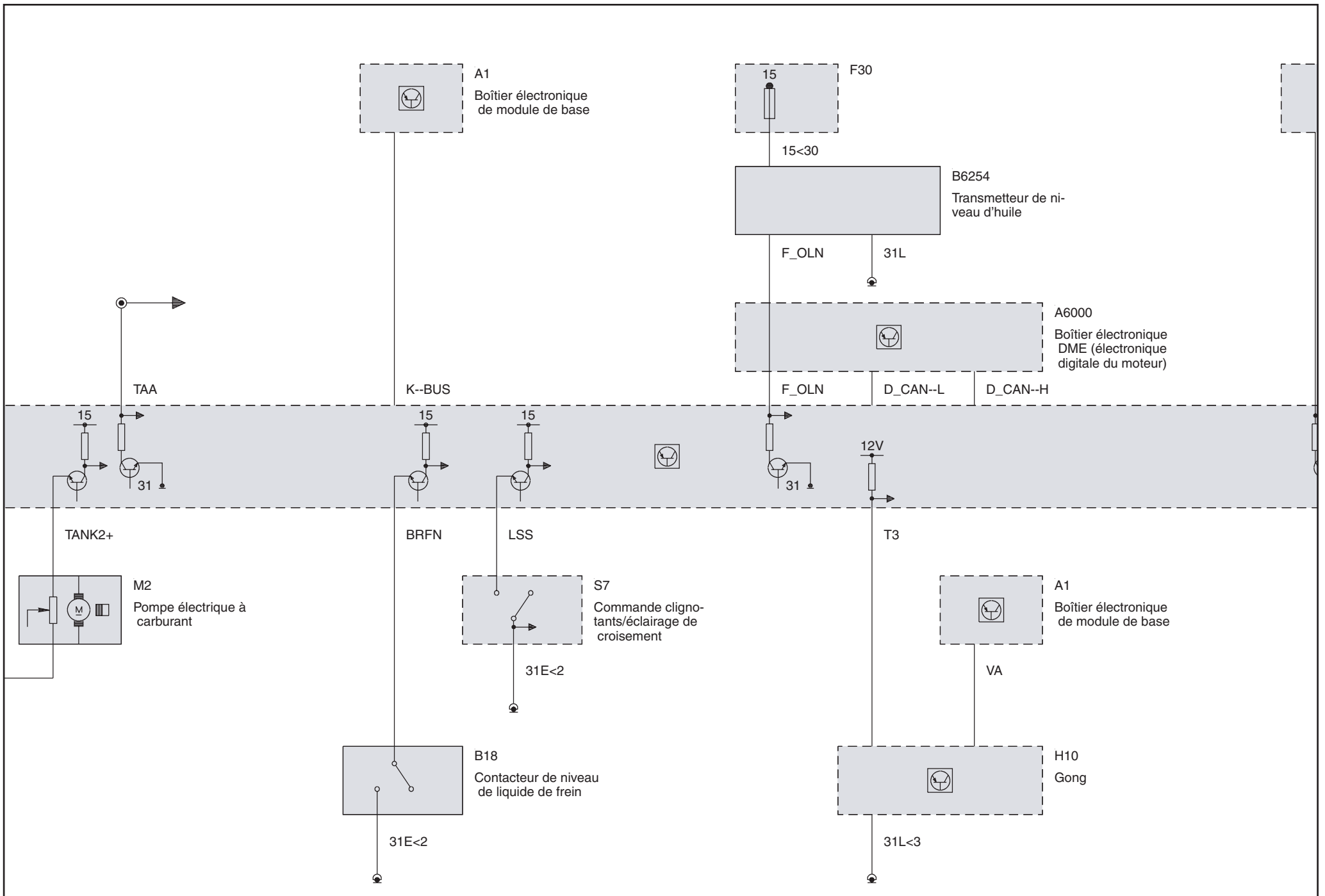

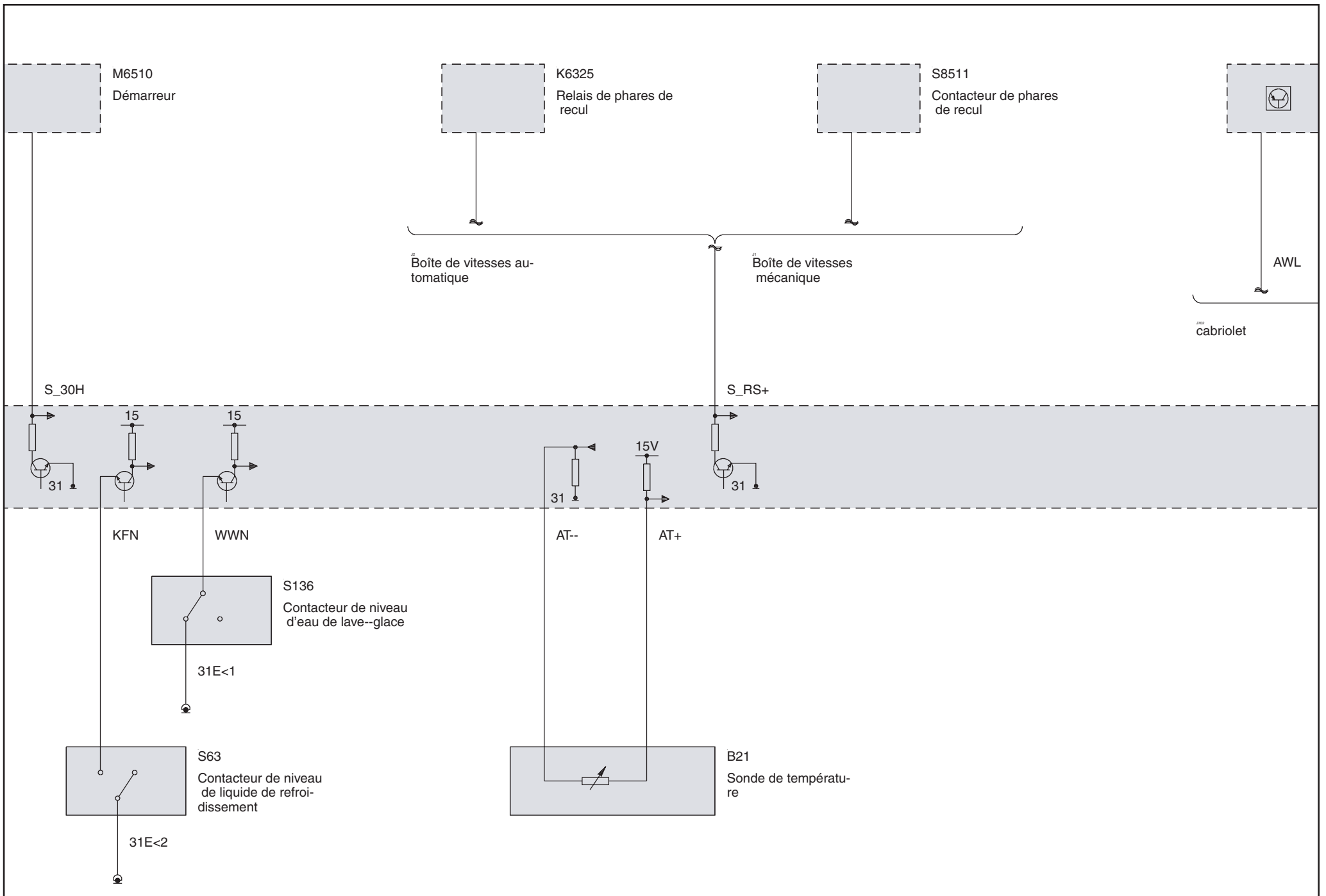

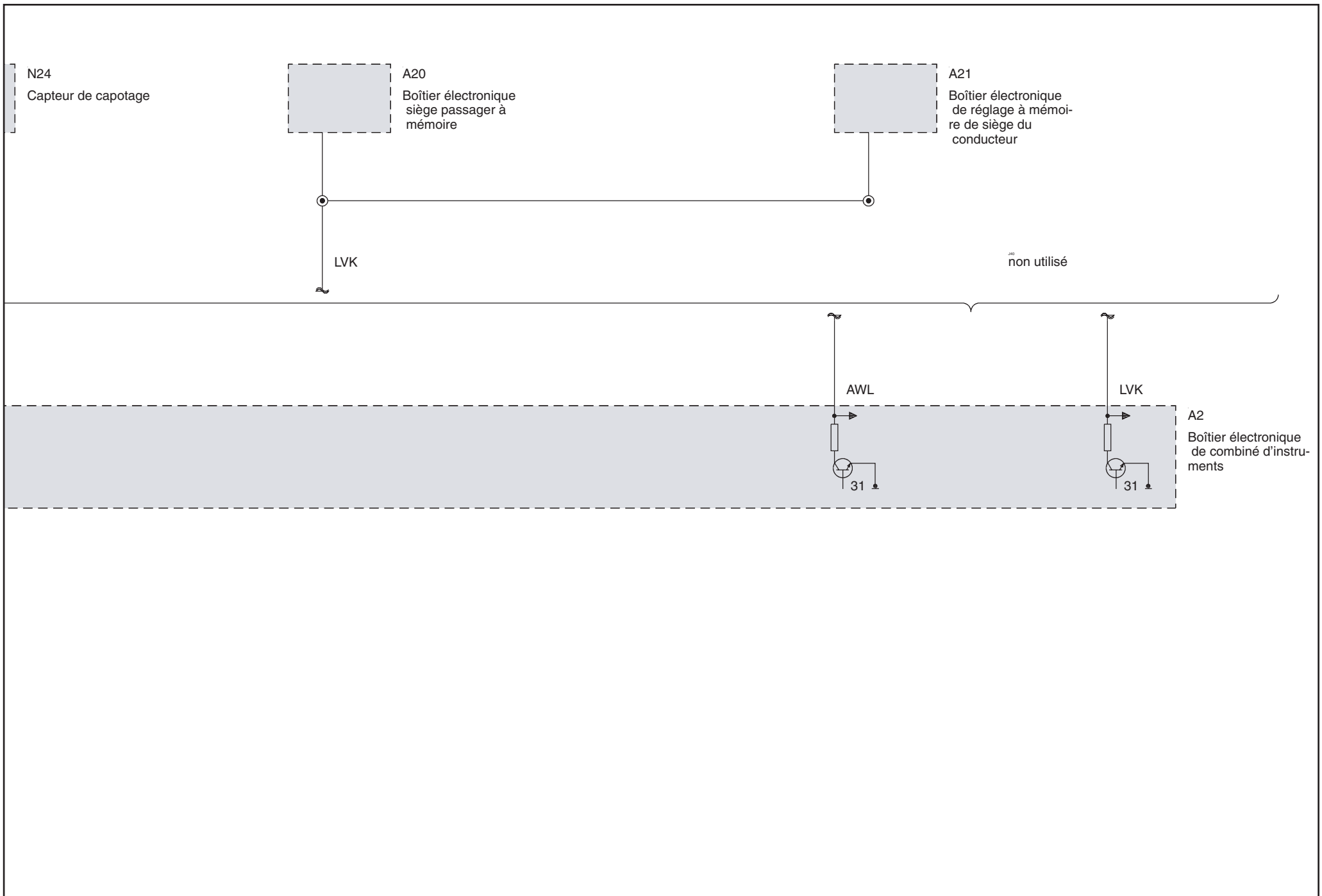



Capteur de niveau d'huile

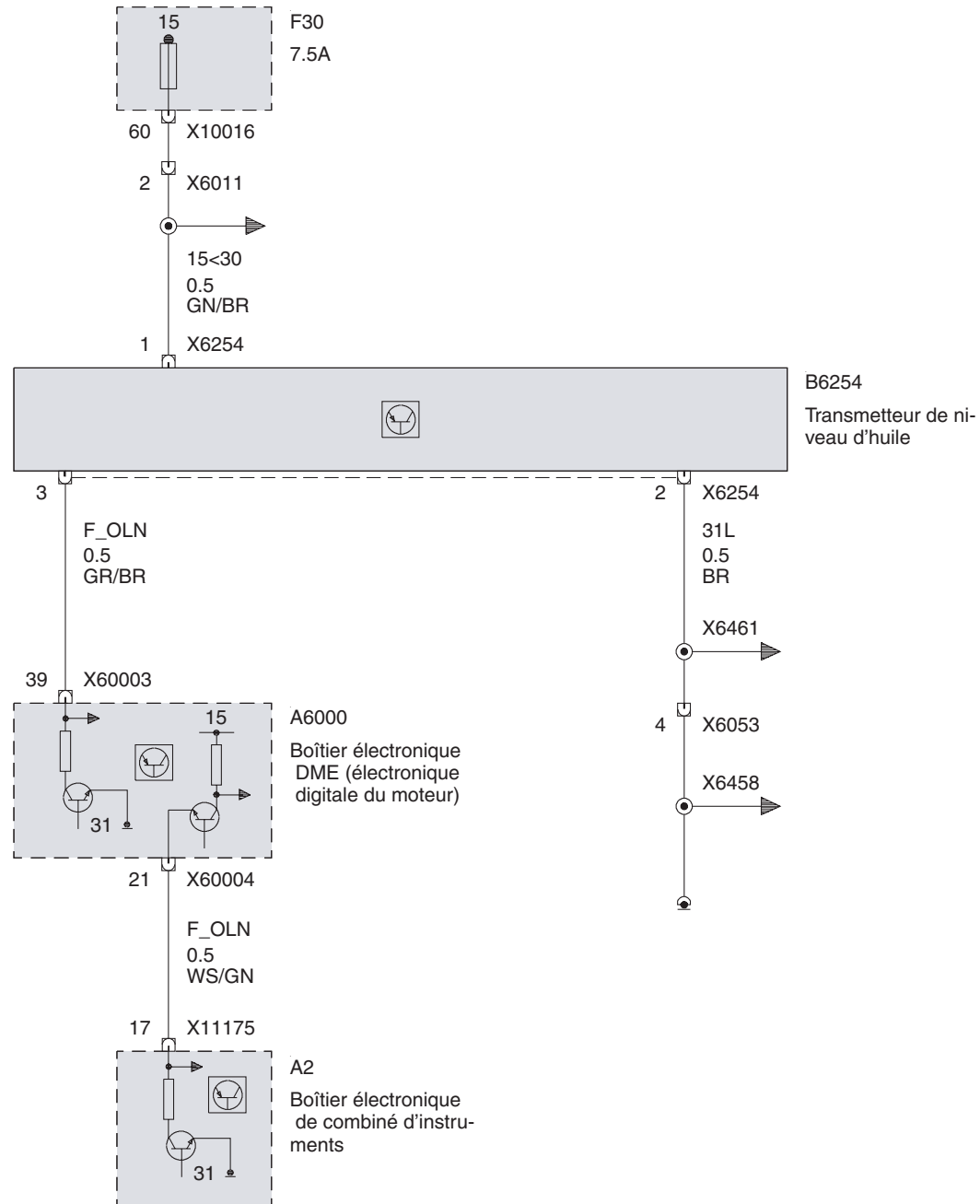

## Température de liquide de refroidissement du moteur

Sonde de température de liquide de refroidissement du moteur

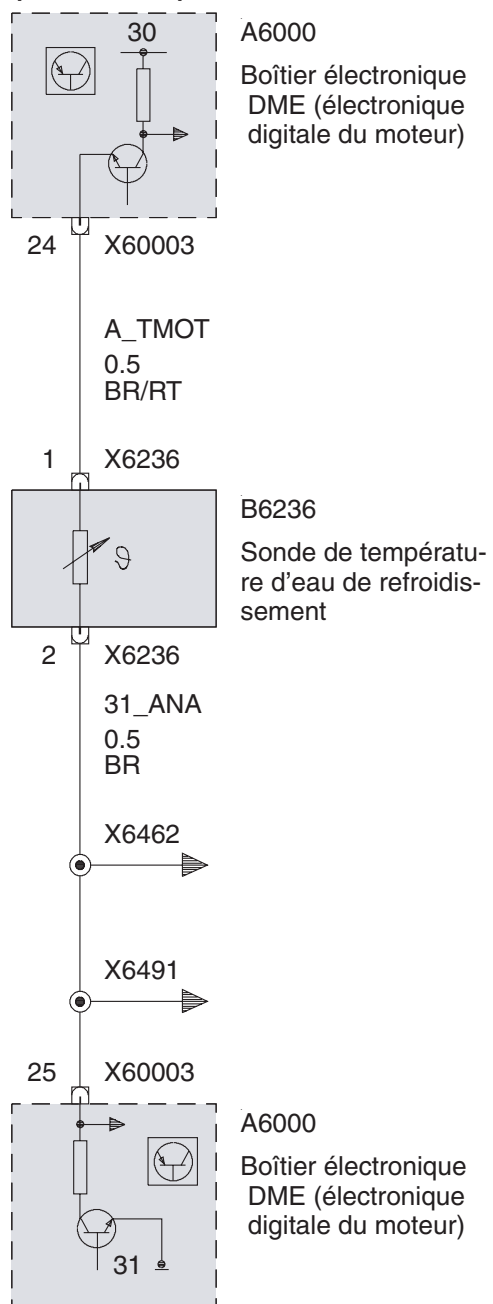

## Température de liquide de refroidissement/ventilateur électrique (jusque 2003\_03)

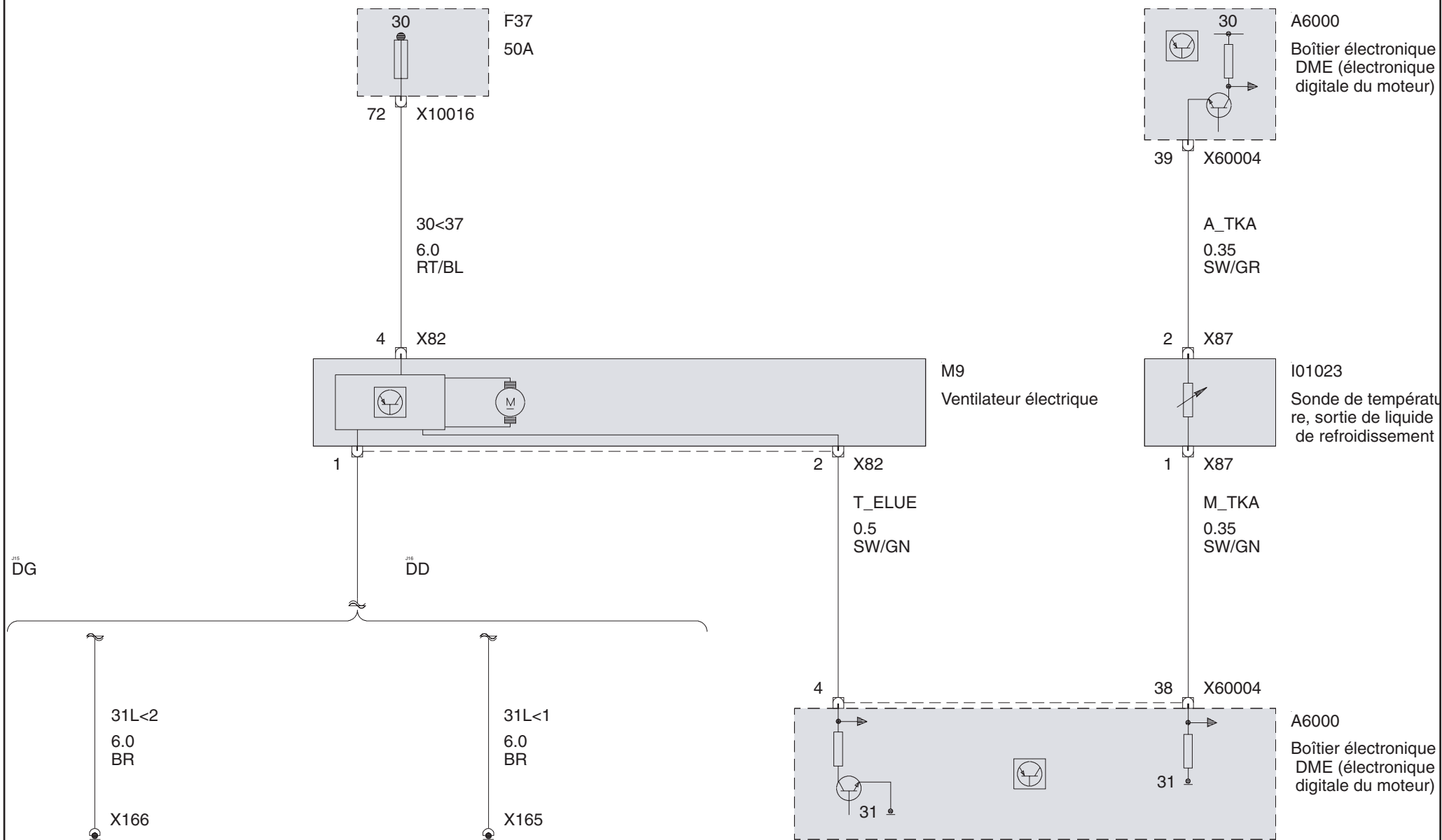

Température de liquide de refroidissement/ventilateur électrique (à partir de 2003\_03)

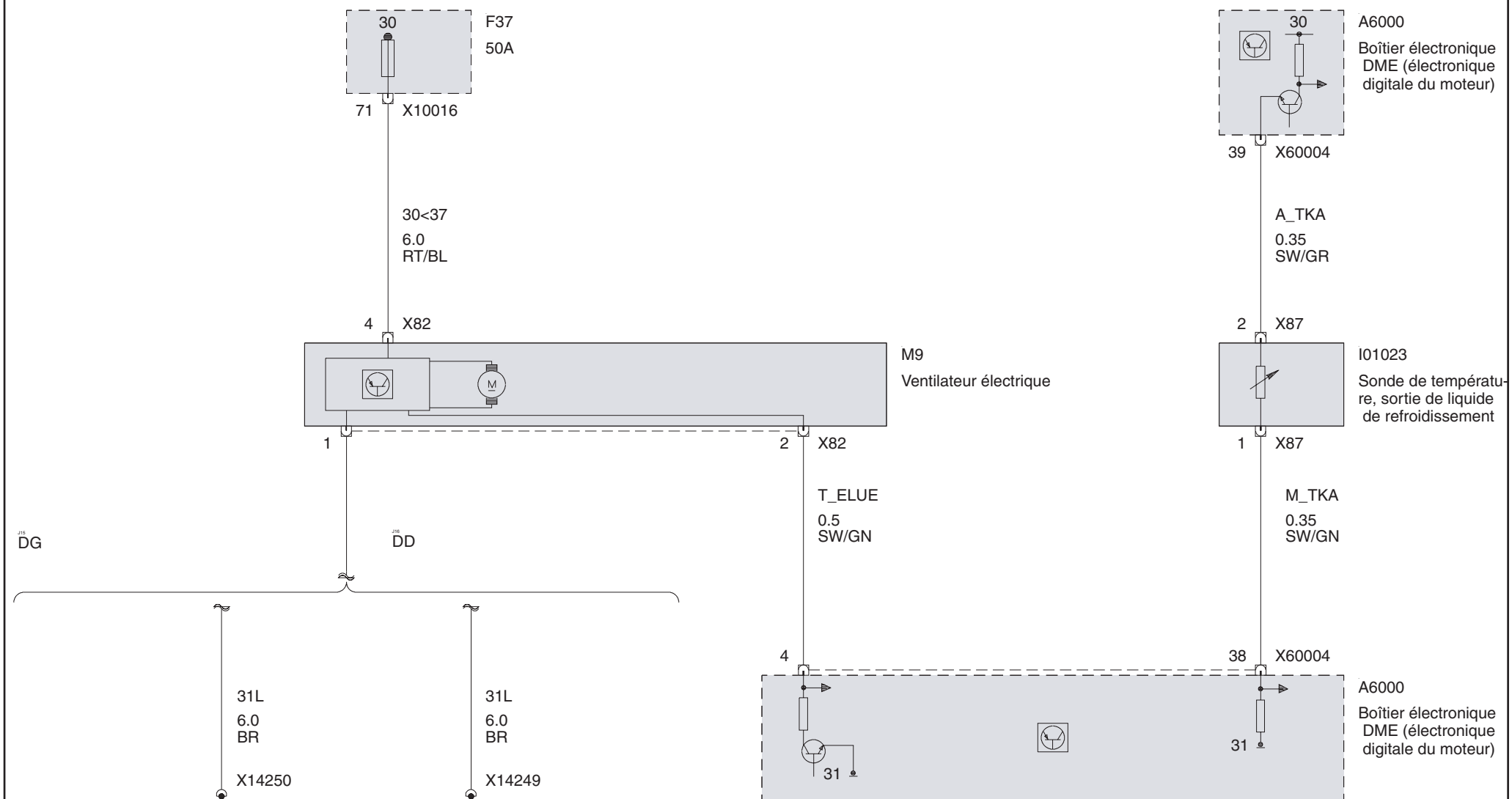

Affichage température extérieure et avertissement de verglas

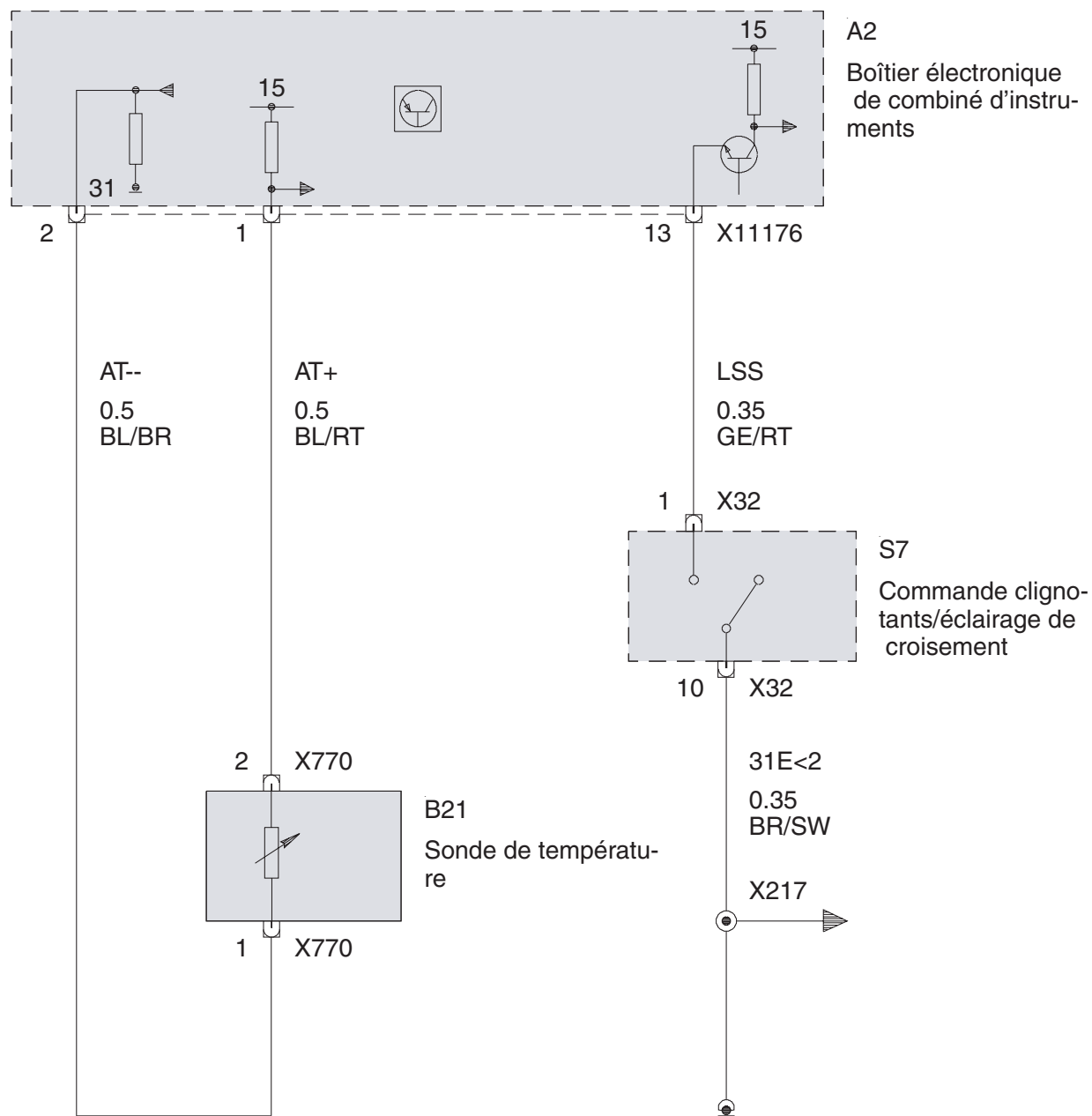

## Affichage vitesse et kilométrage

Signal traité de vitesse de roue arrière gauche (ASC MK20 contrôle automatique de stabilité)

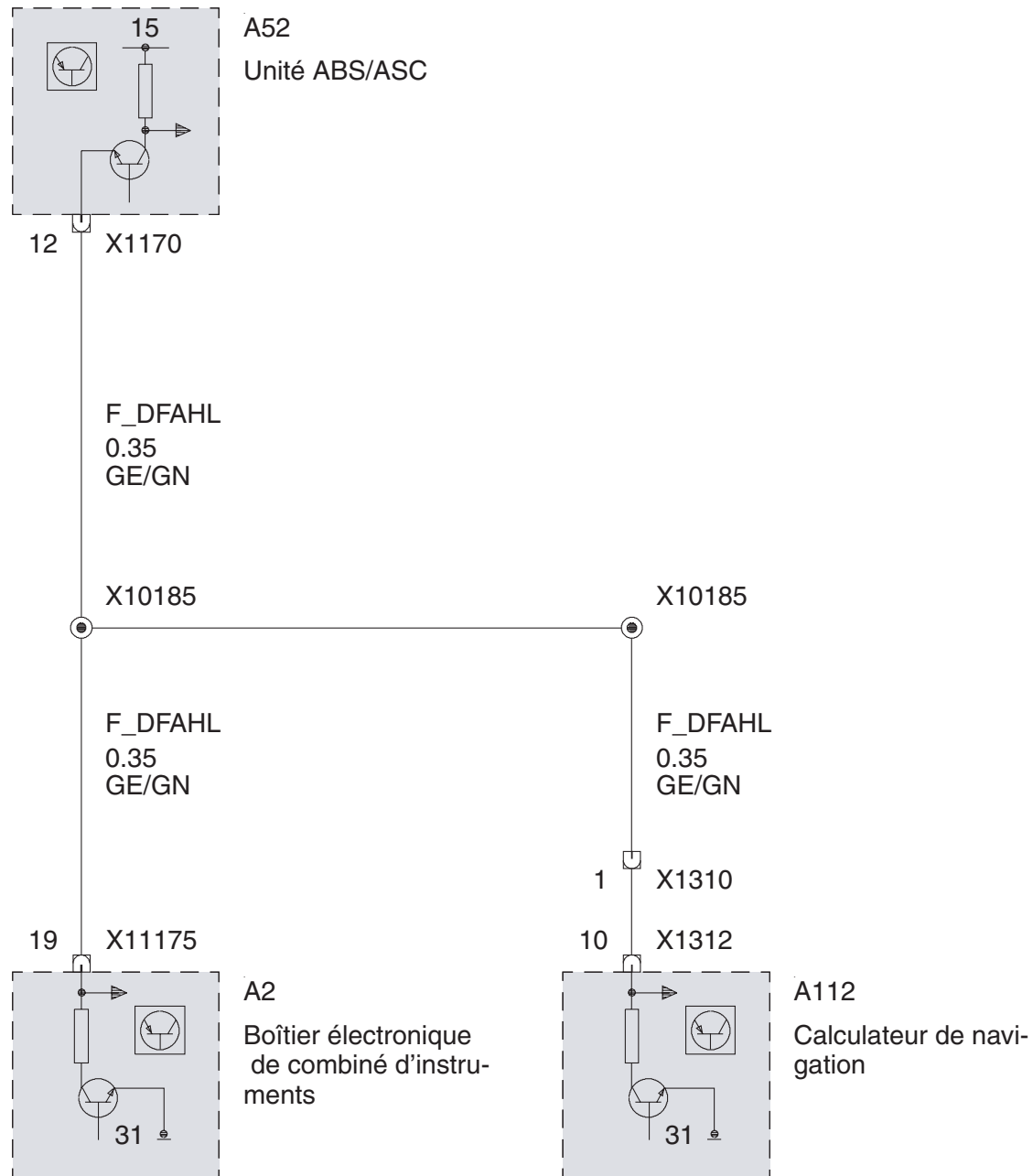

## Signal traité de vitesse de roue arrière gauche (DSC MK20 Contrôle dynamique de stabilité)

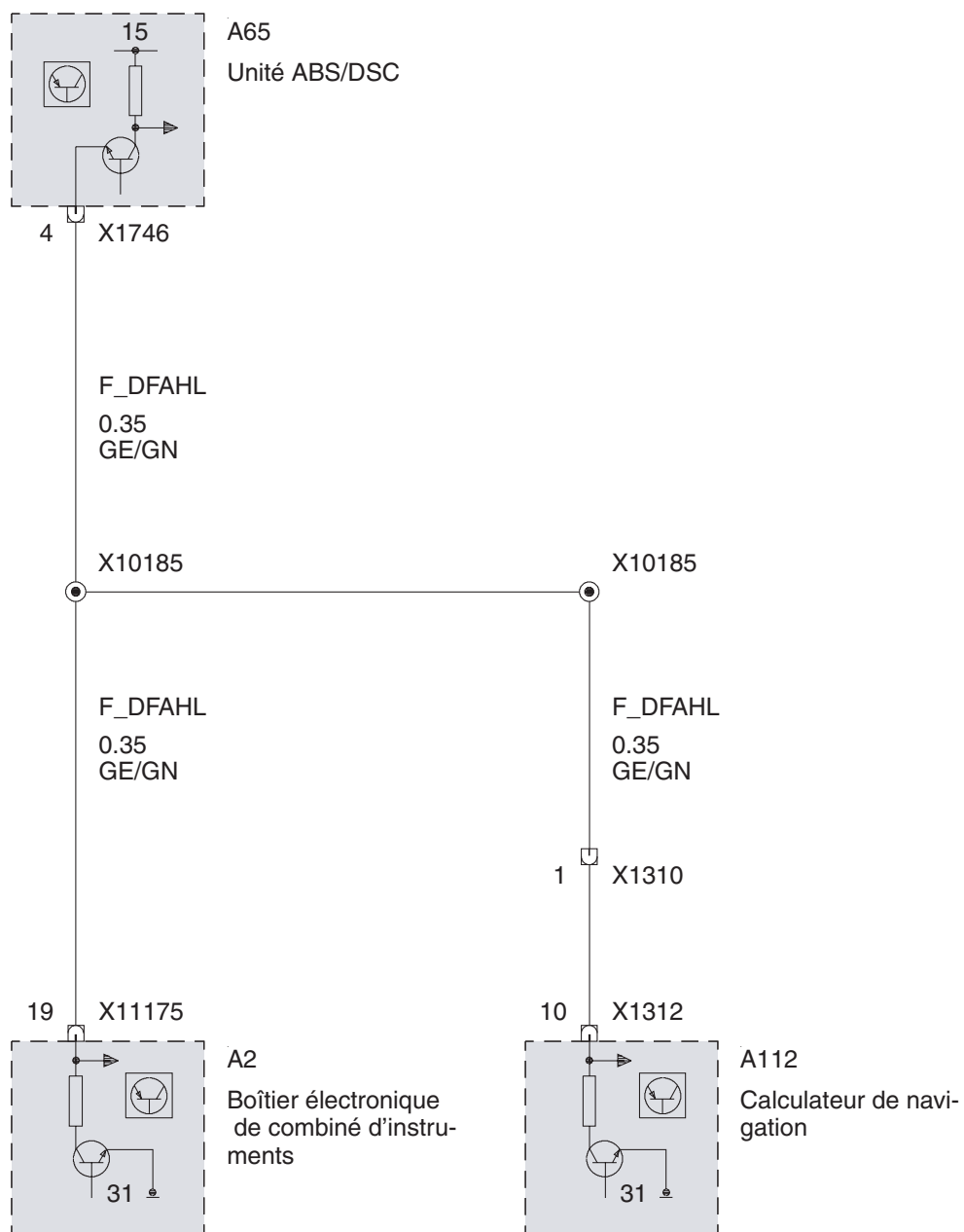

## Signal traité de vitesse de roue arrière gauche (ASC MK60)

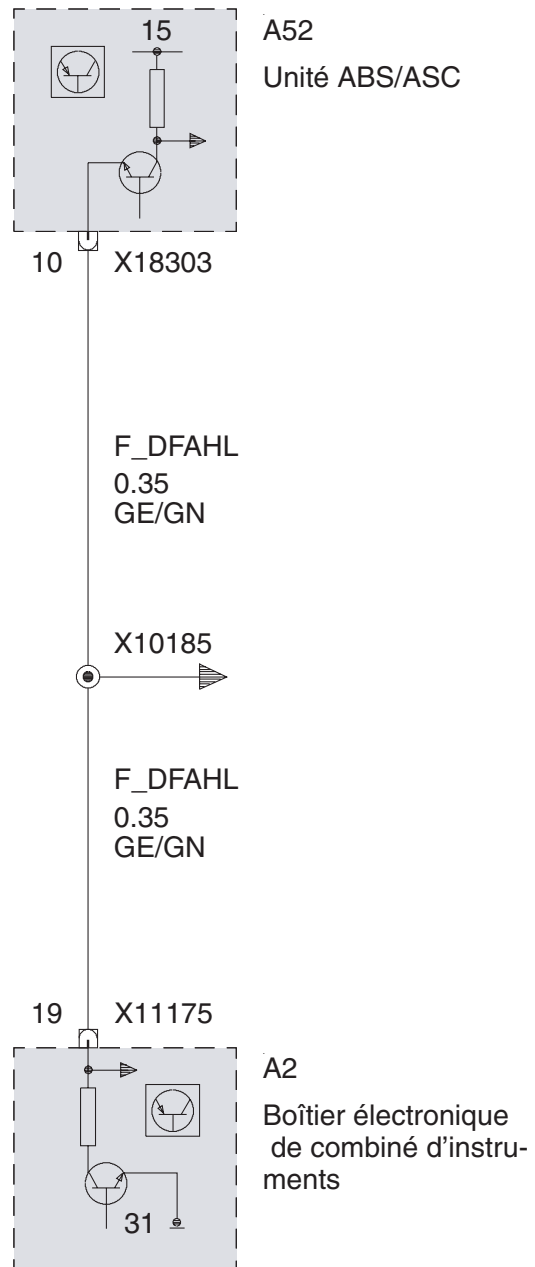



Signal traité de vitesse de roue arrière gauche (DSC MK60)

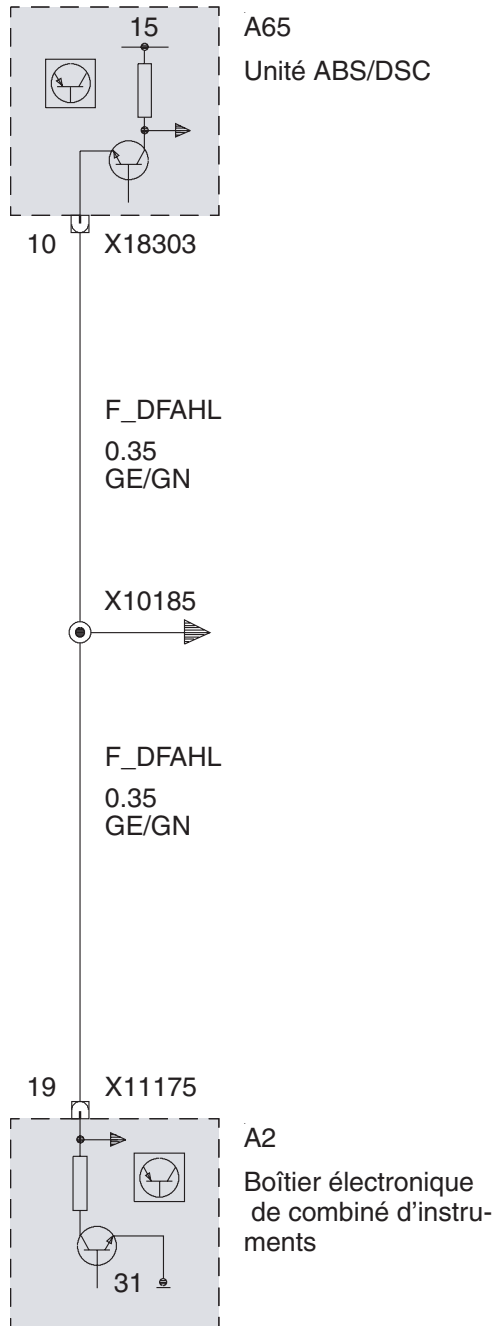

Jauges I et II de réservoir de carburant

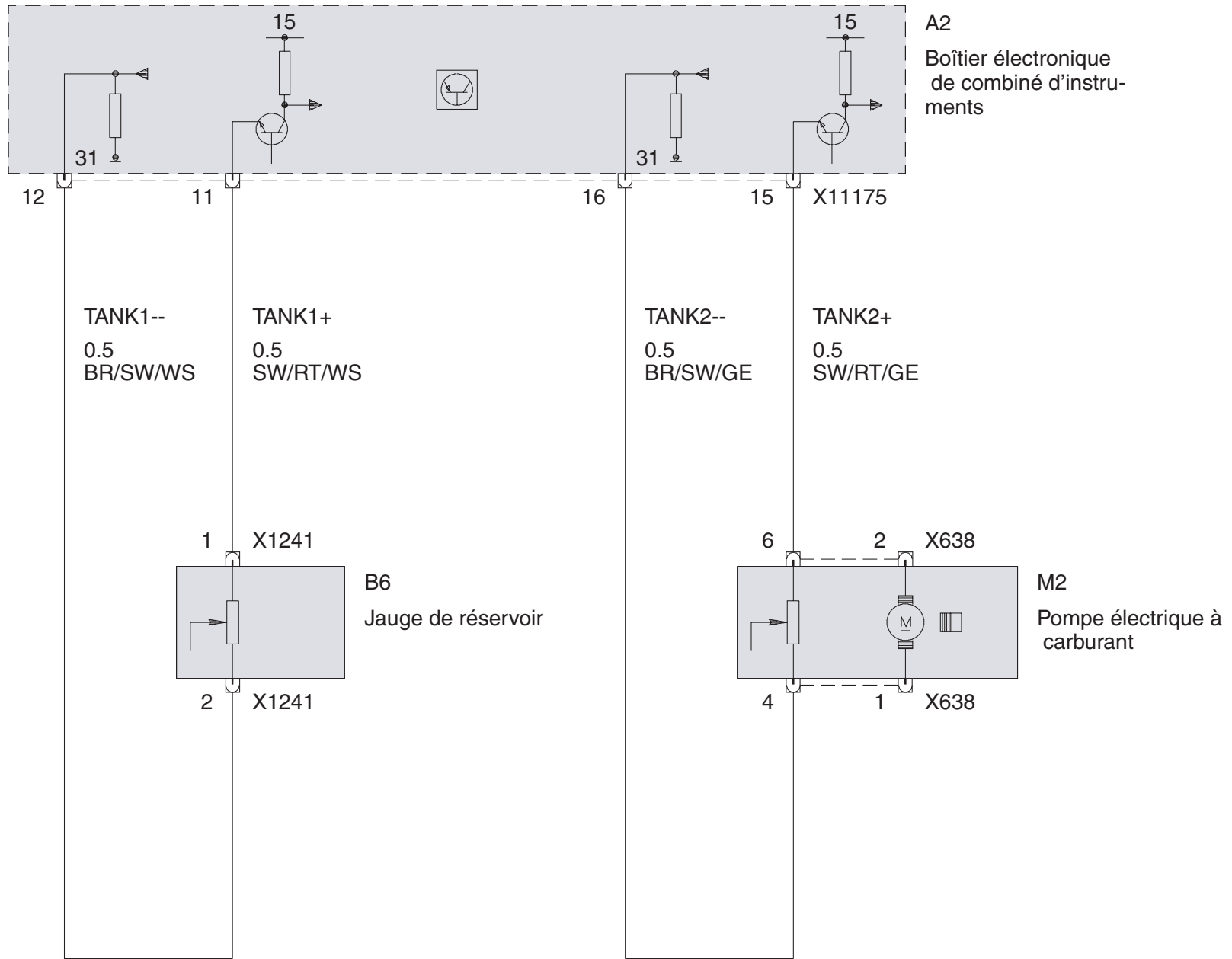

## Réglage luminosité instrumentation

Connecteur d'éclairage des instruments et de repérage des commandes X1019 (à partir de 1999\_09 jusque 2003\_03)

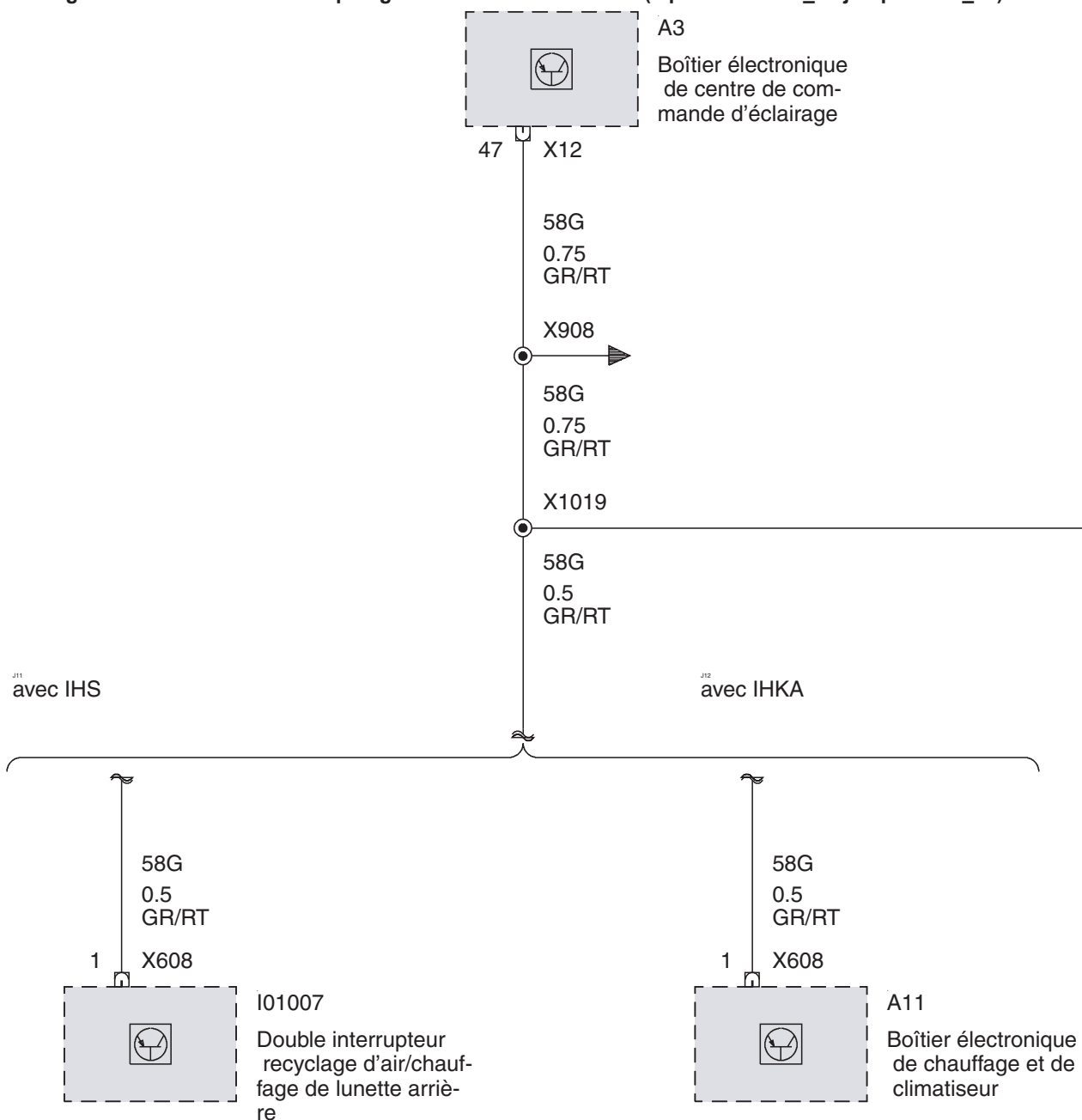

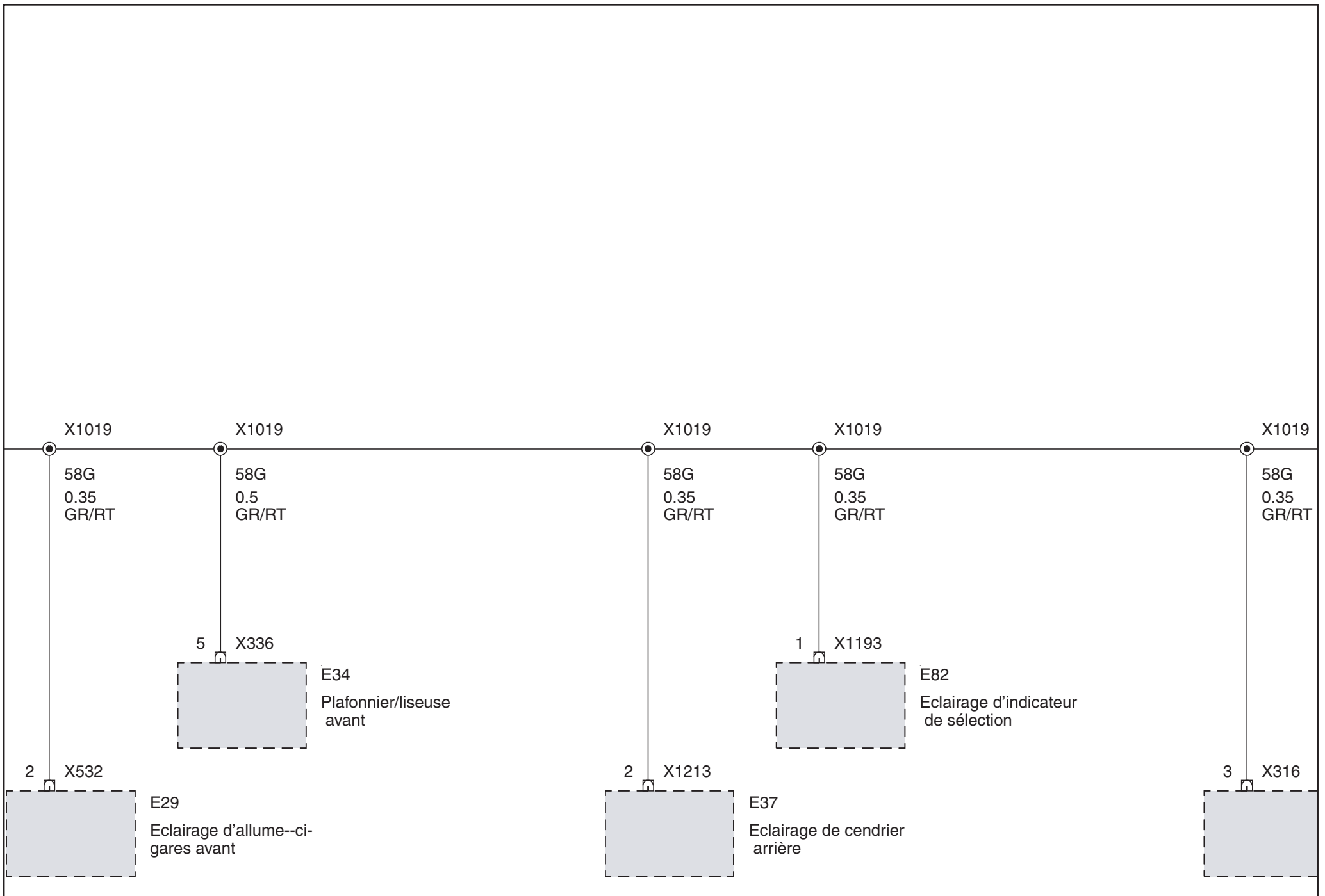

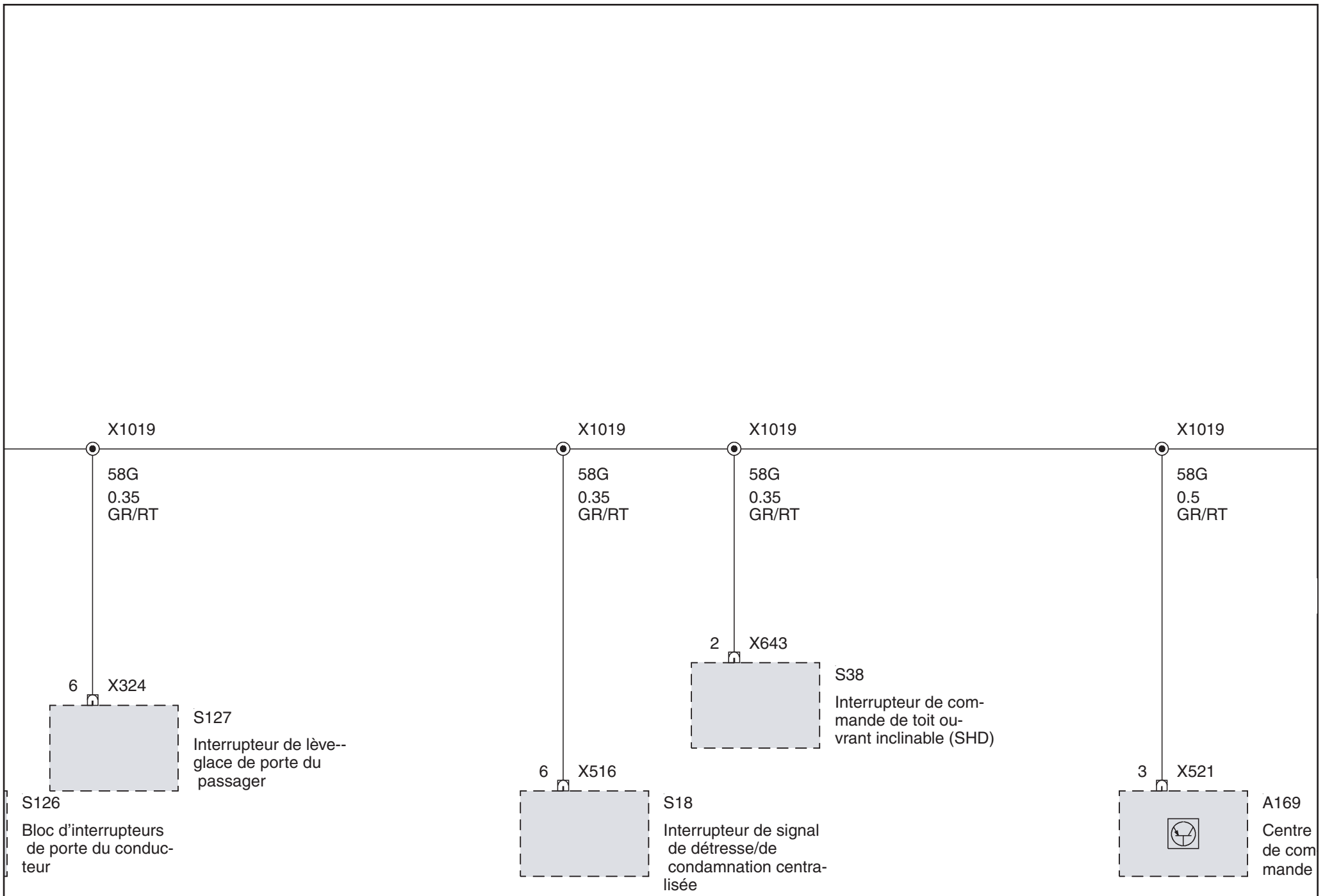

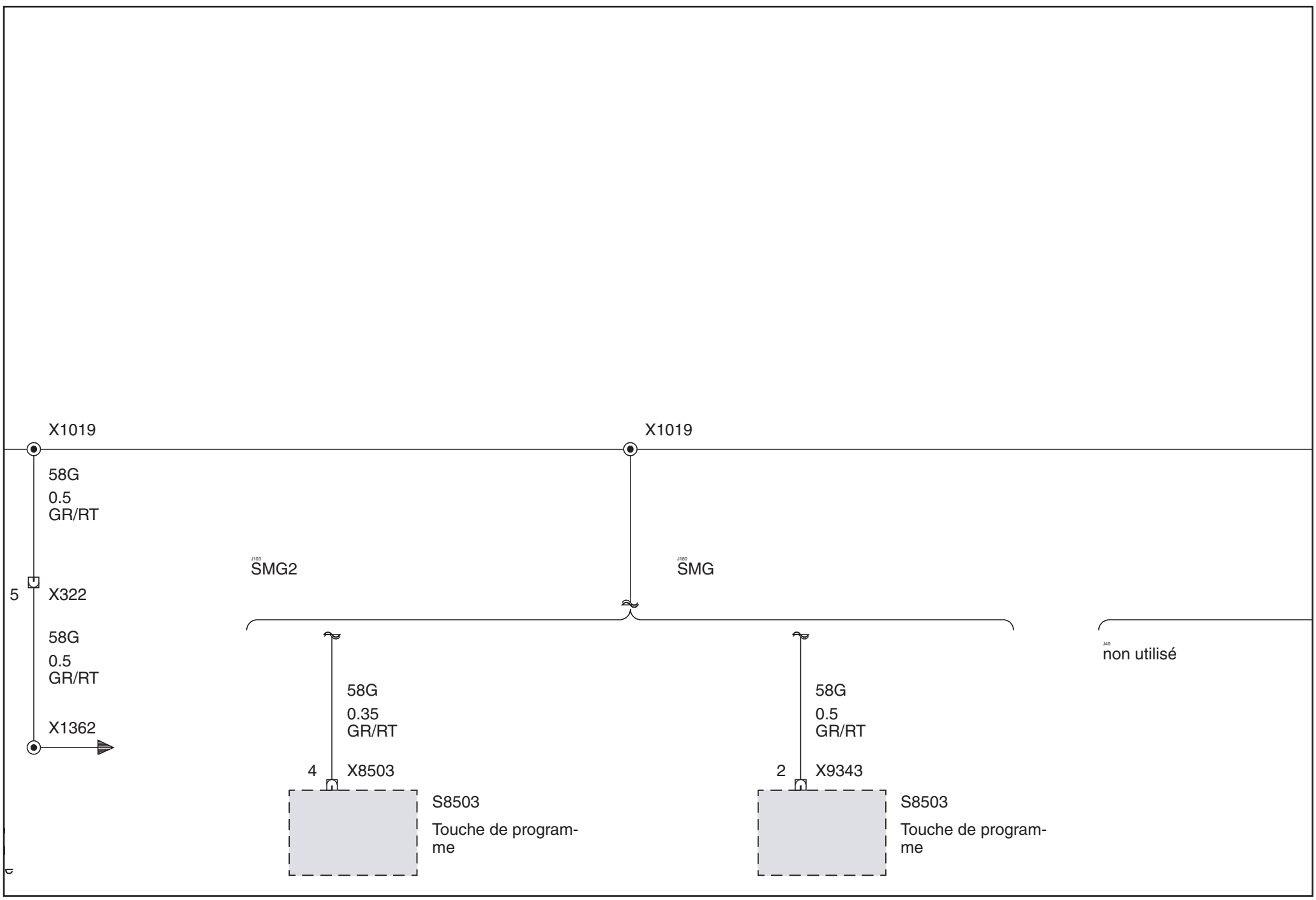

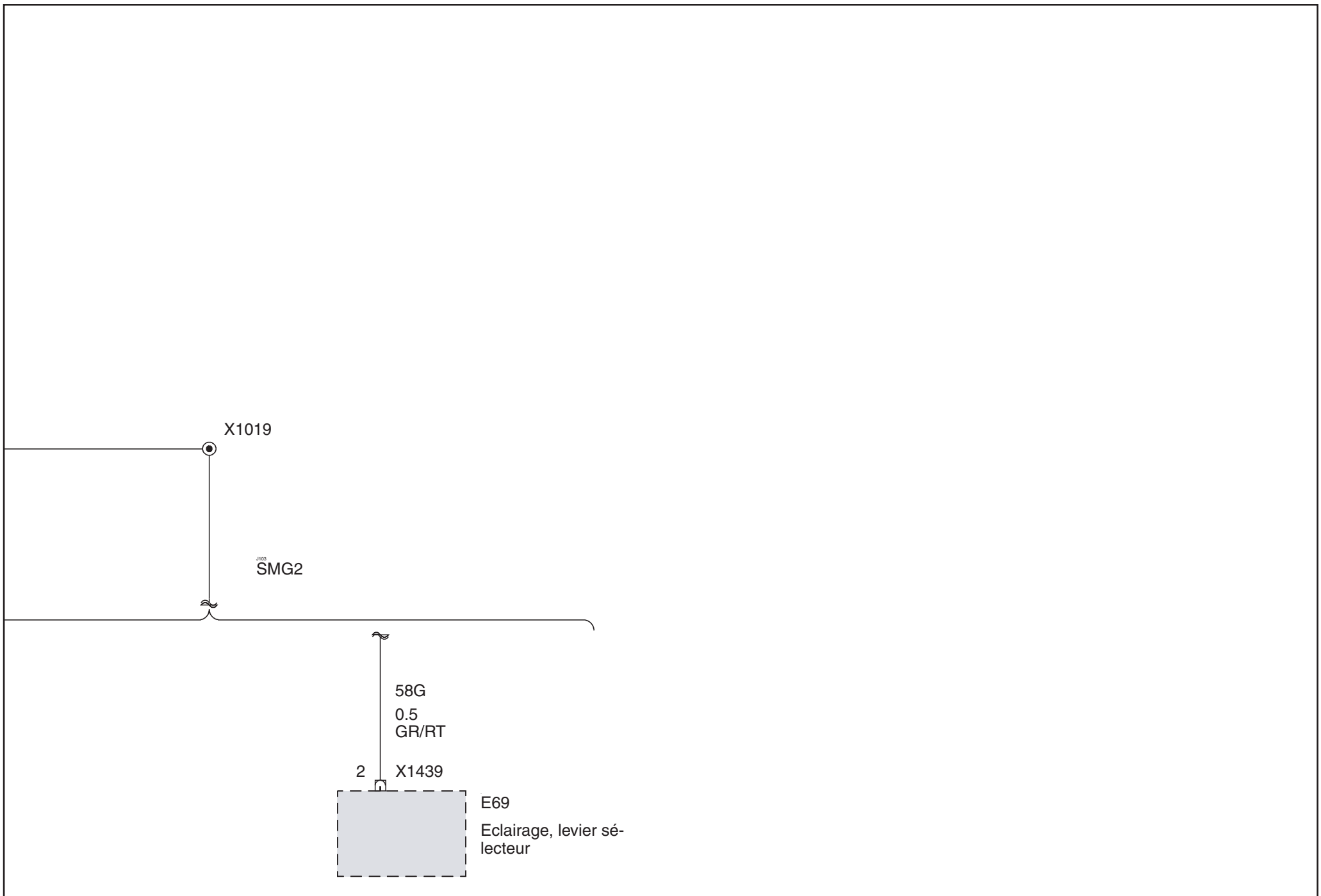

Connecteur d'éclairage des instruments et de repérage des commandes X1019 (à partir de 2003\_03)

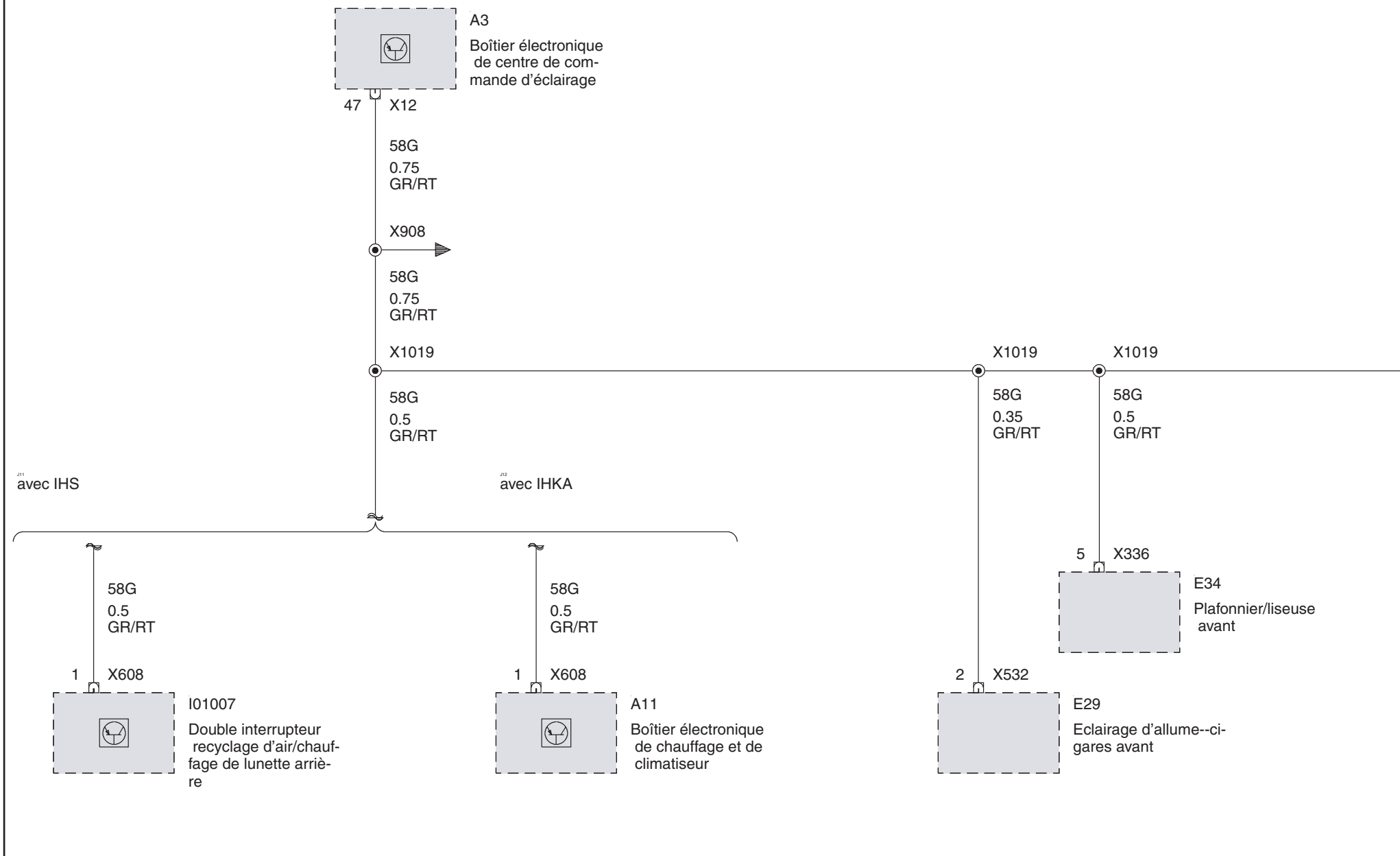



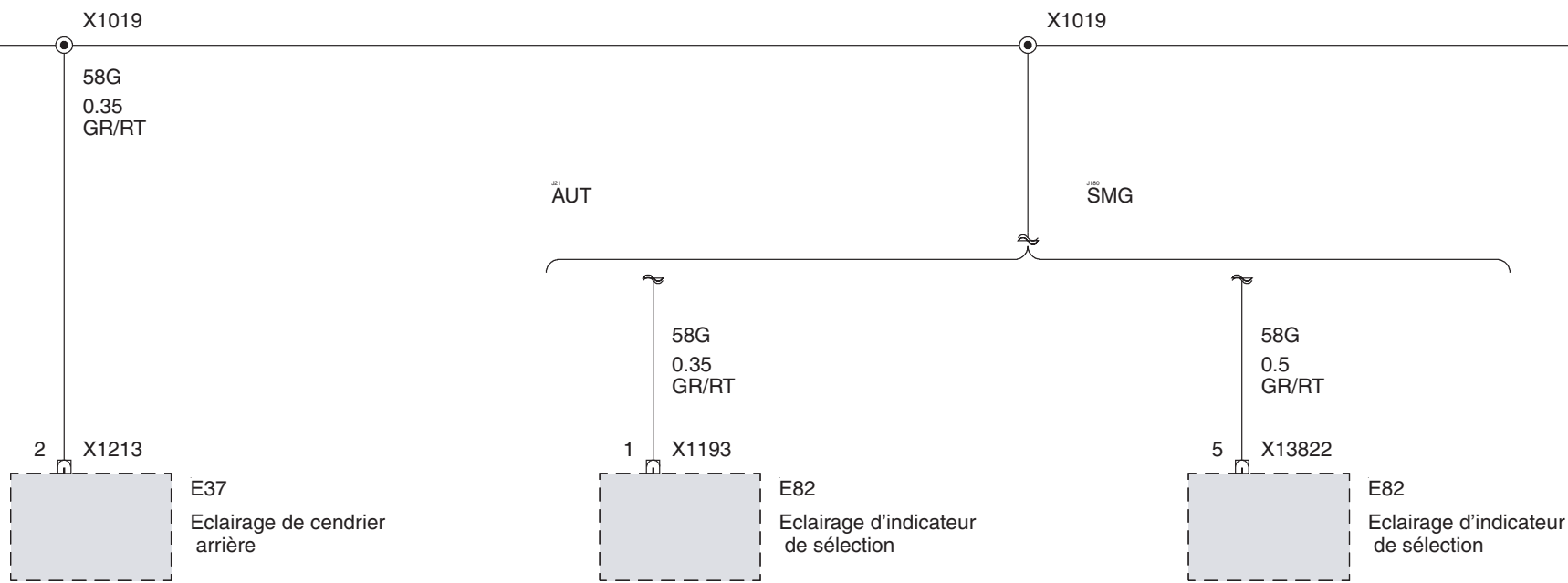

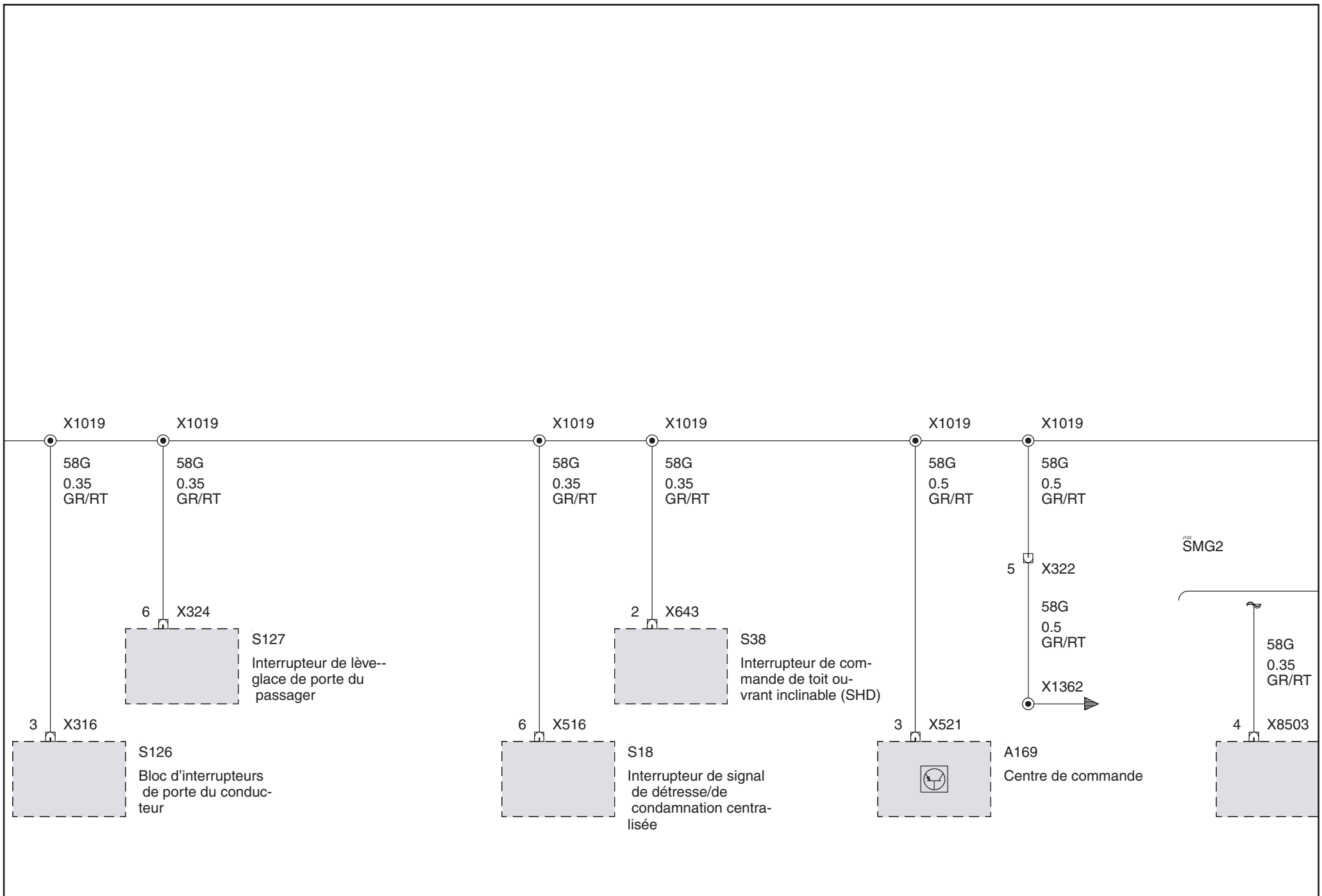

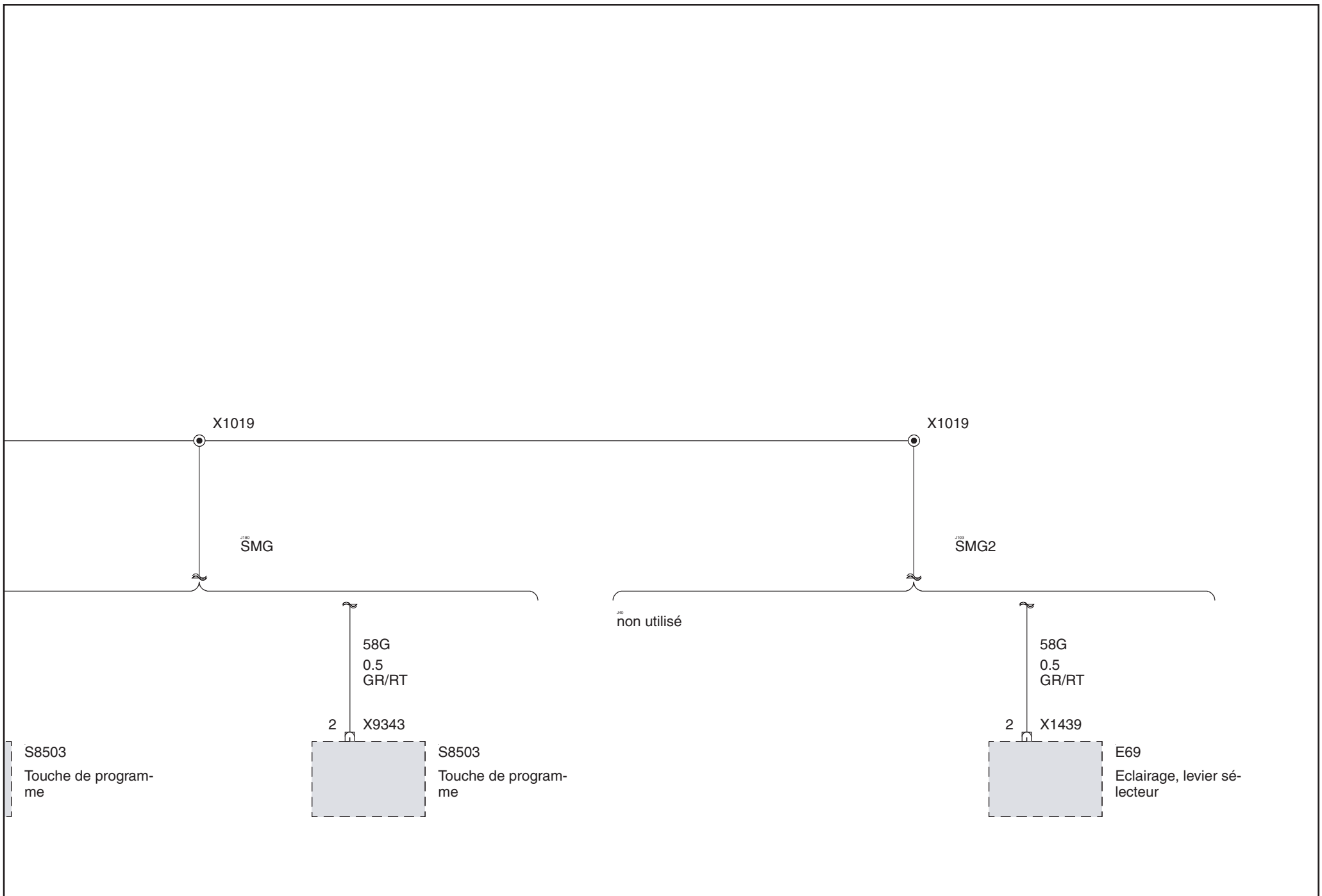

Pictogramme Check Control, montre, kilométrage journalier ; Contrôle clignotants, feux de route, projecteurs et feux arrière antibrouillard ; Signalisation acoustique

Connecteur X10116 (Coupé ou Cabriolet)

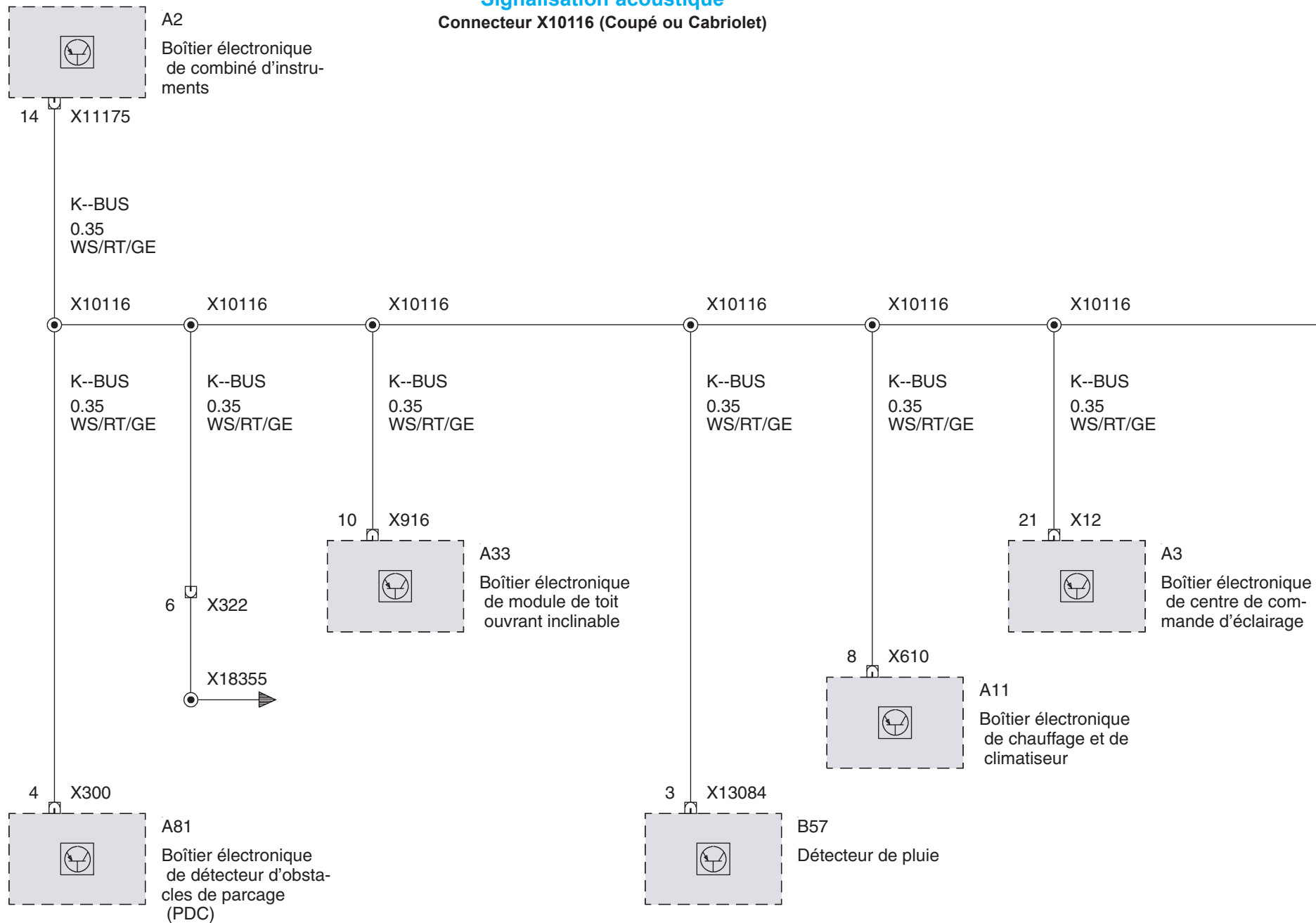

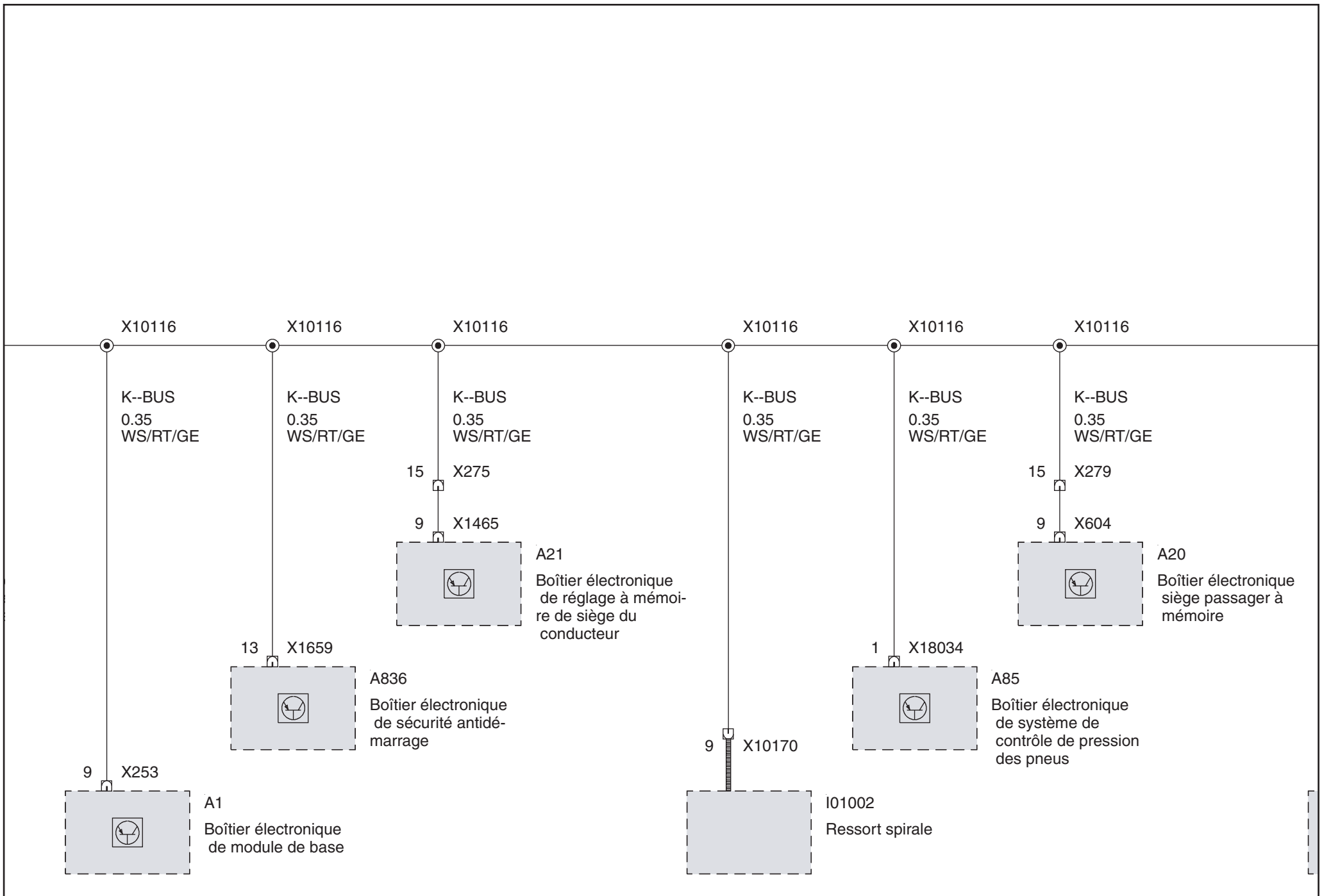

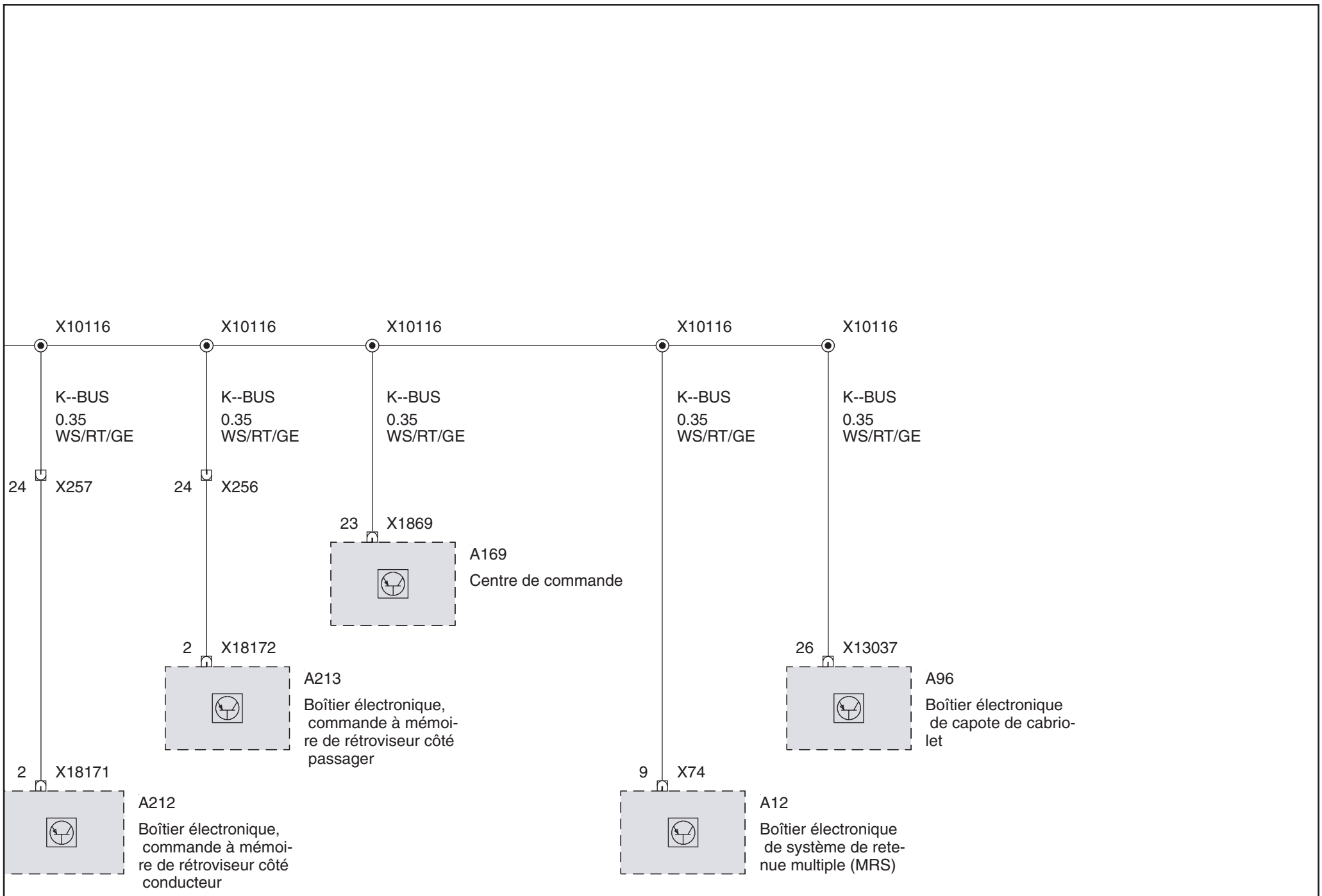

Connecteur X10116 (Berline ou Touring ou Compact)

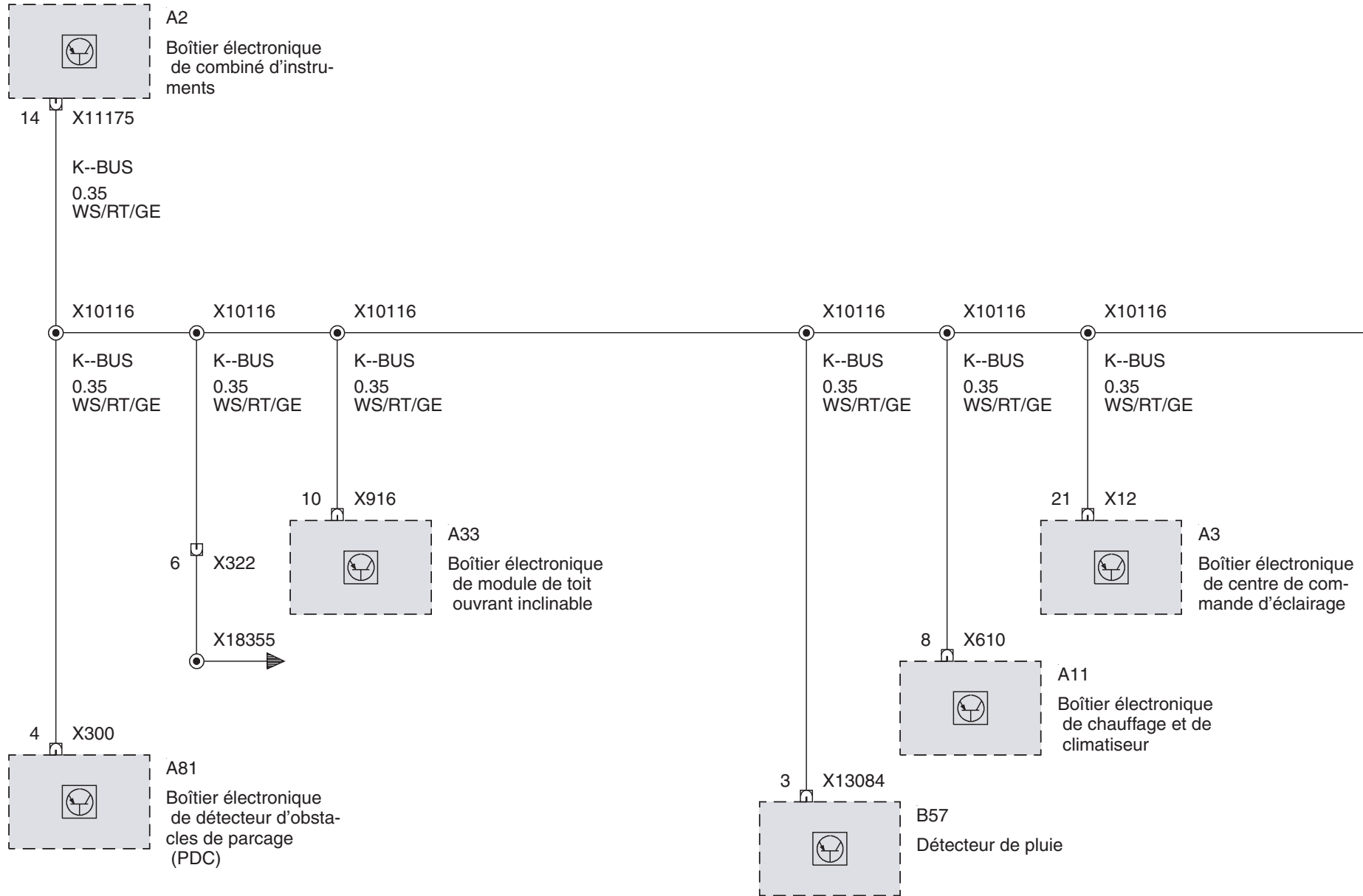

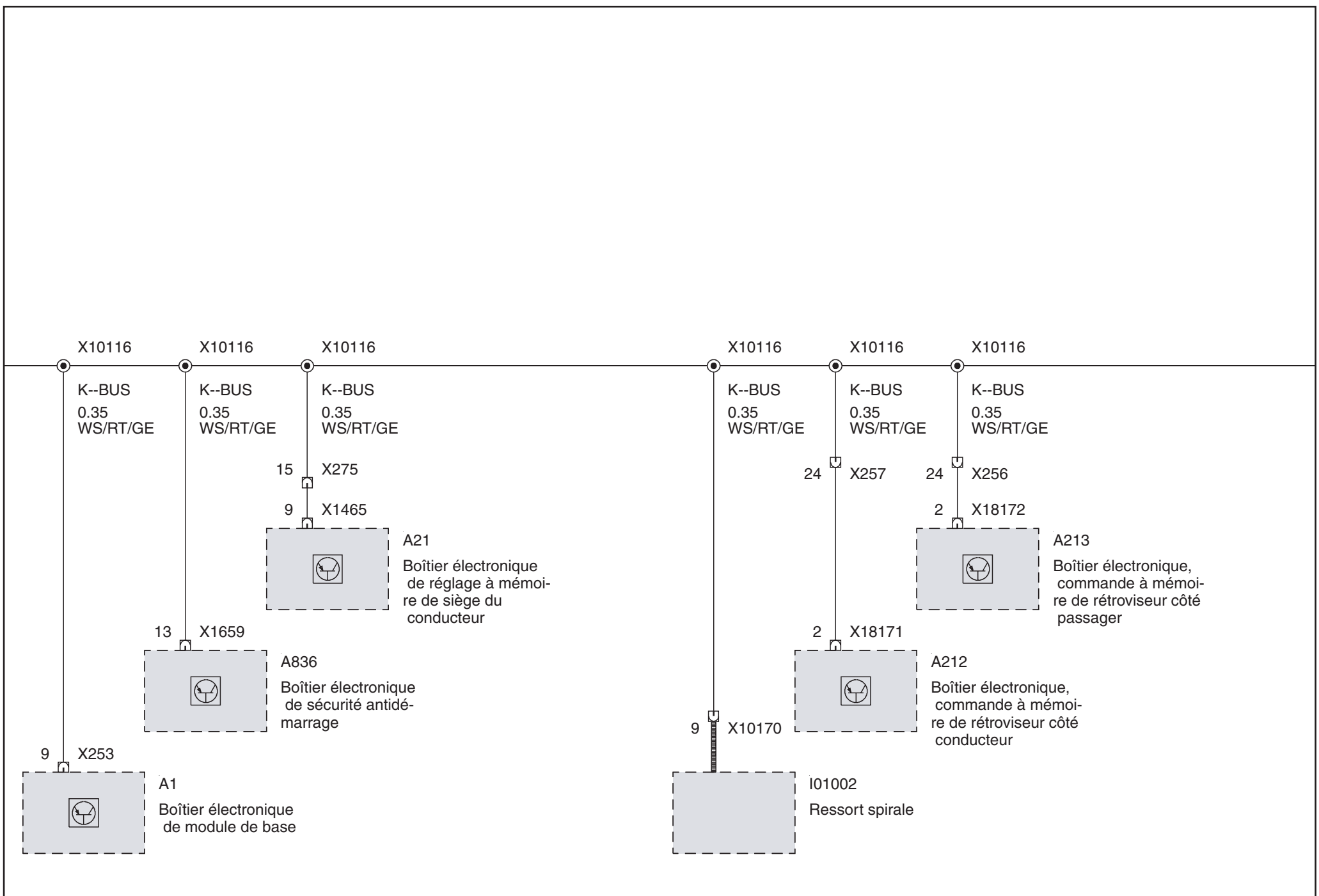



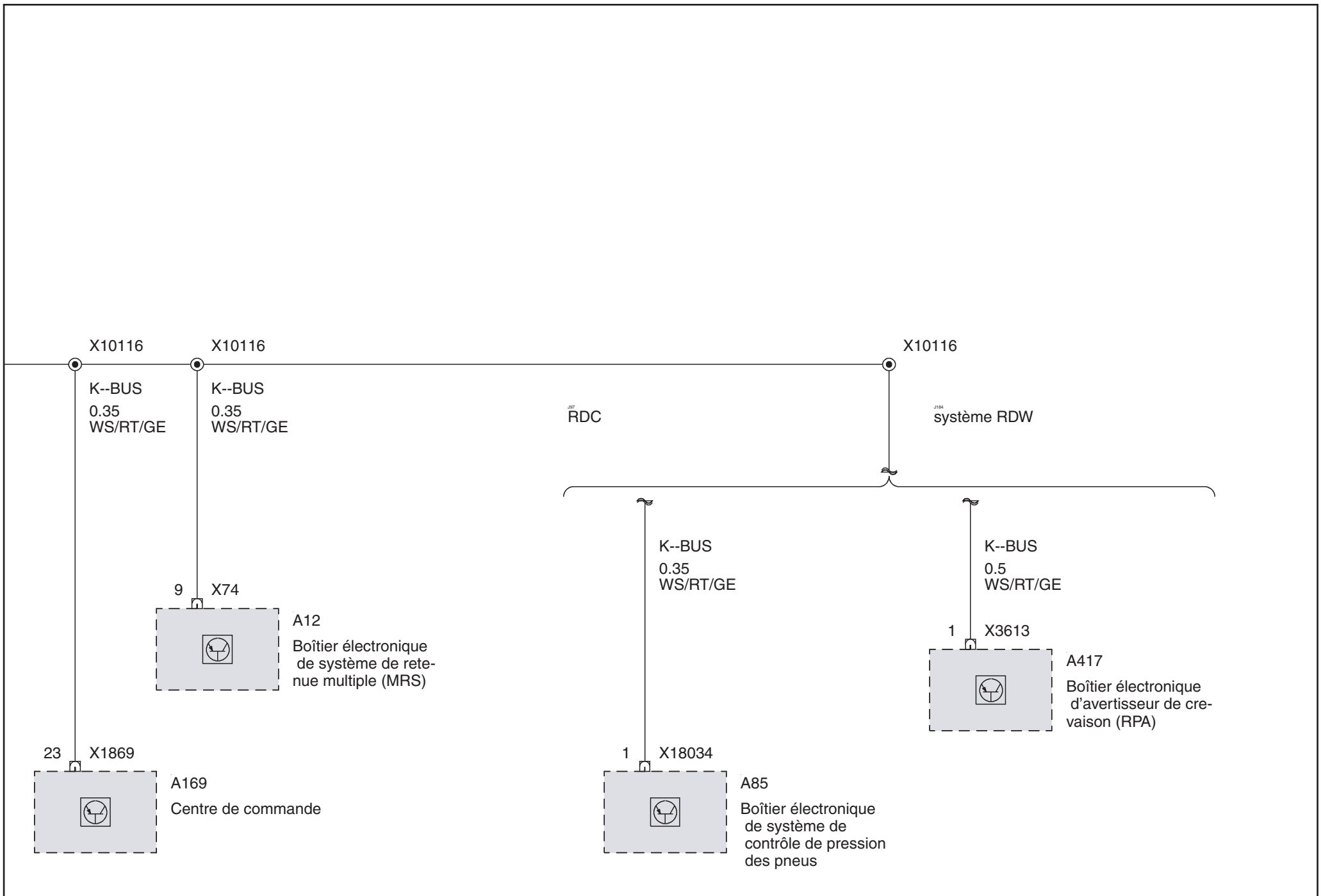

### Indicateur de maintenance OBDII prise de courant (DDE Electronique Diesel DDE50)

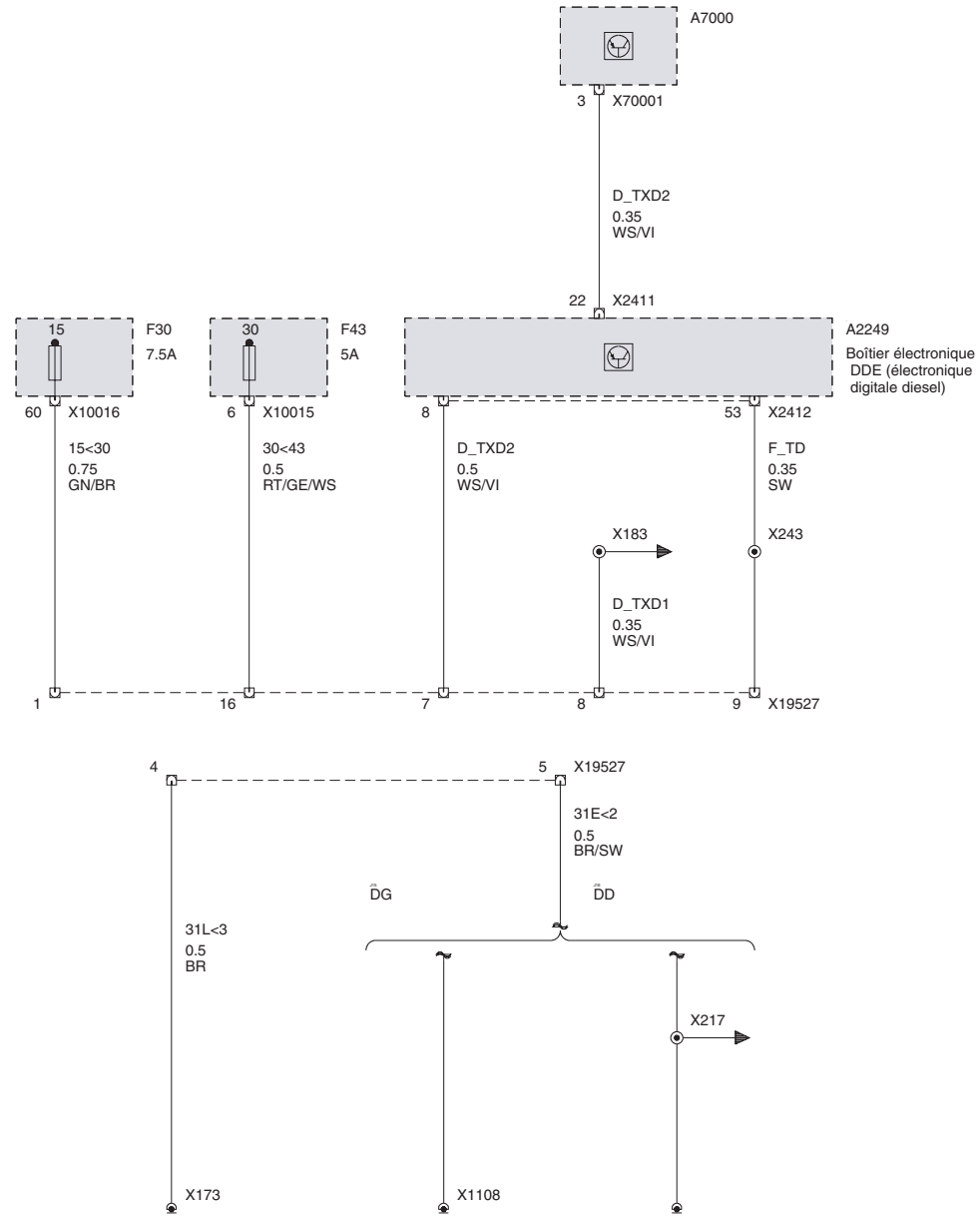

OBDII prise de courant (Essence)

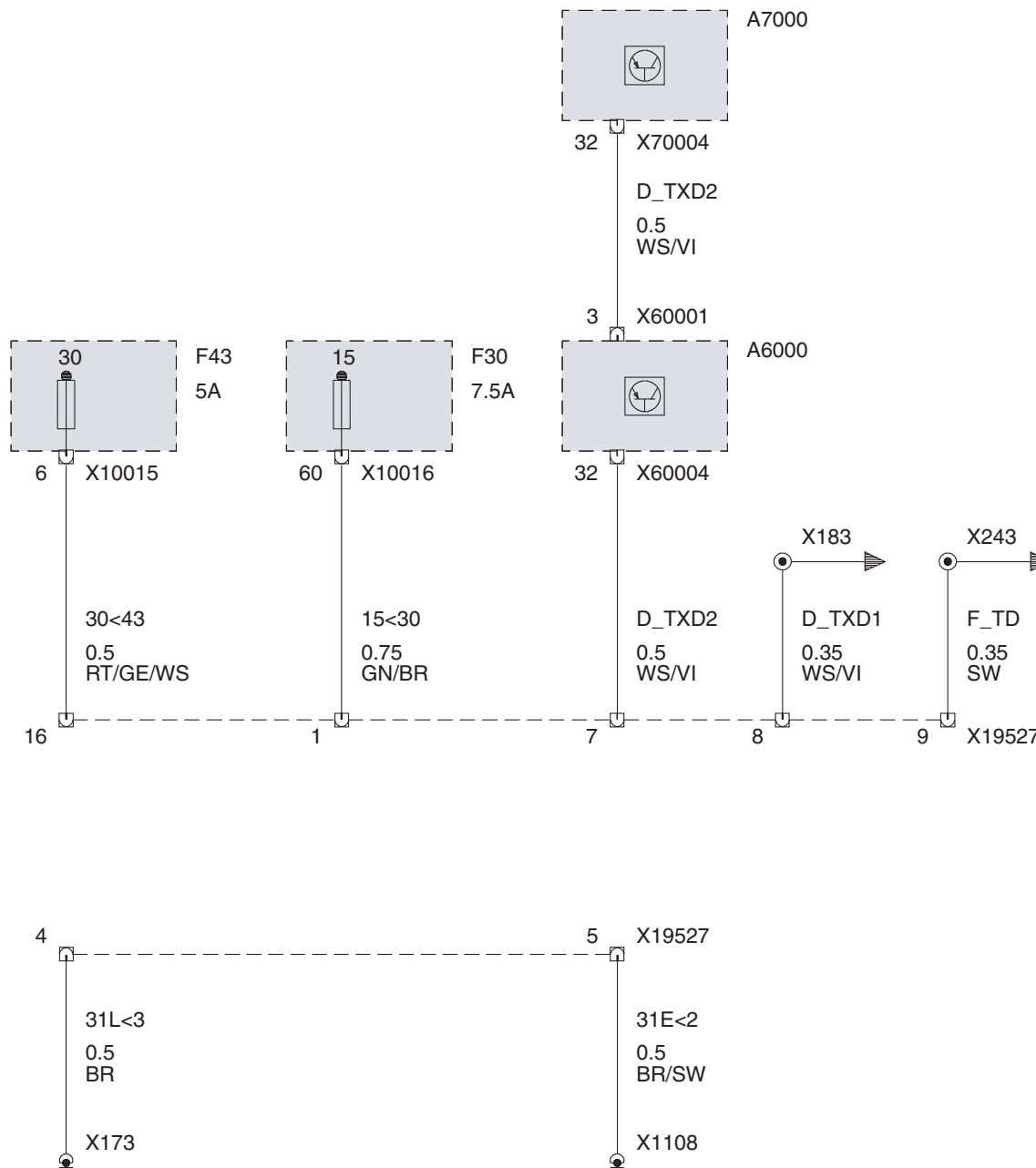

Niveau liquide de refroidissement

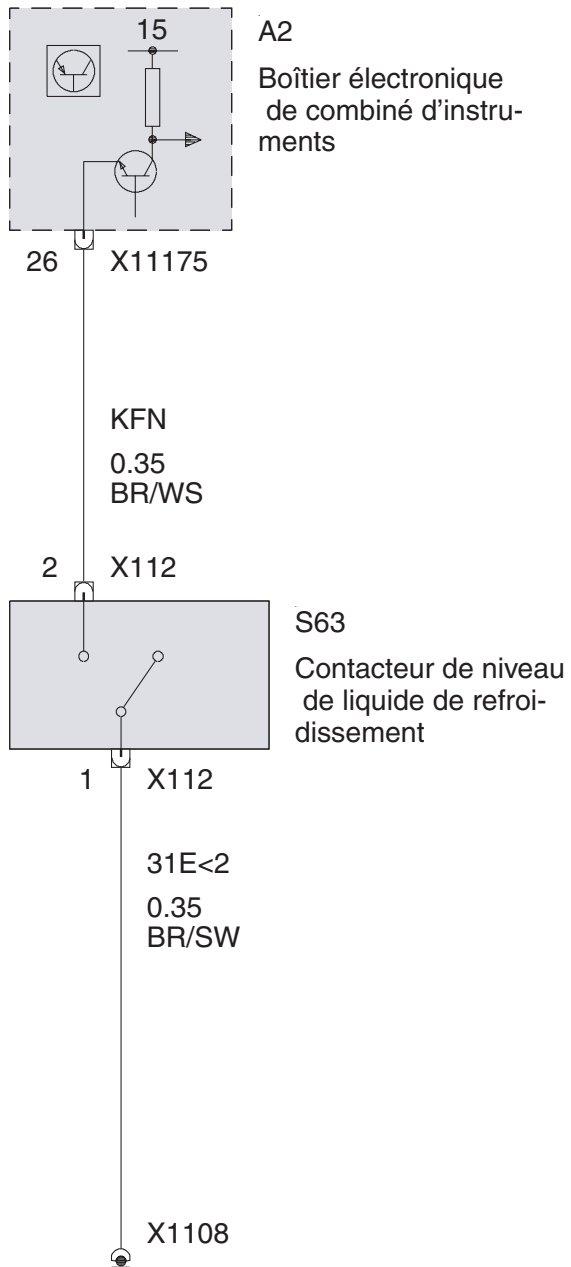

## Alerte pression et niveau d'huile

Témoin de pression d'huile ( DME Electronique moteur MS43 ou DME Electronique moteur ME9 )

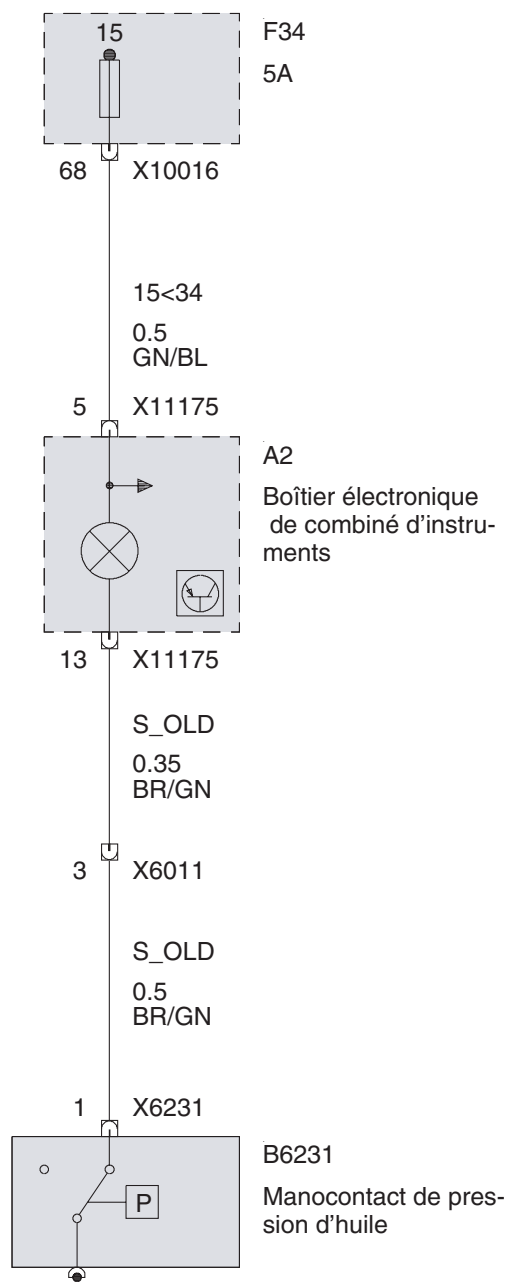

Alimentation en huile moteur (DDE Electronique Diesel DDE50 jusque 2003\_03)

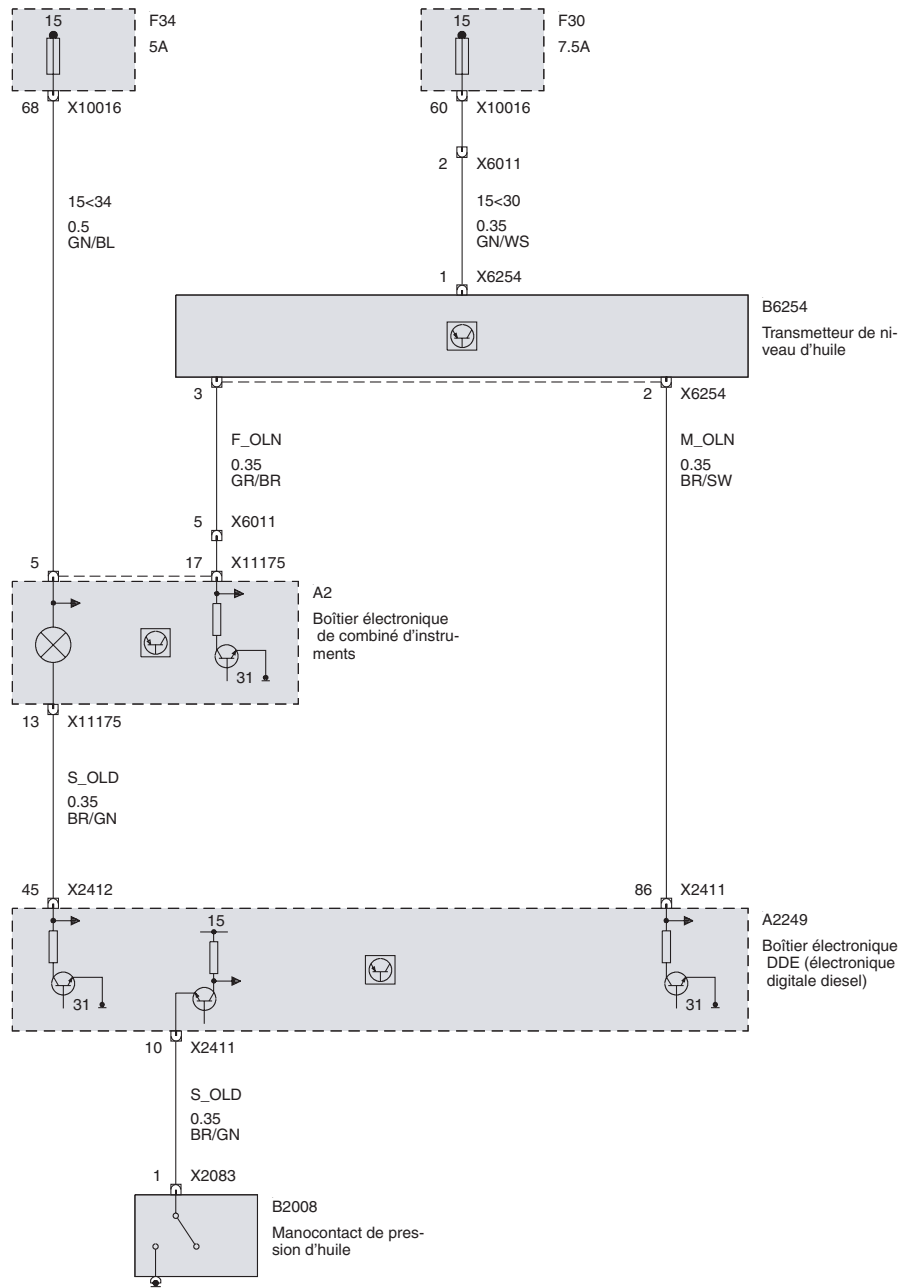

Alimentation en huile moteur (DDE Electronique Diesel DDE50 à partir de 2003\_03)

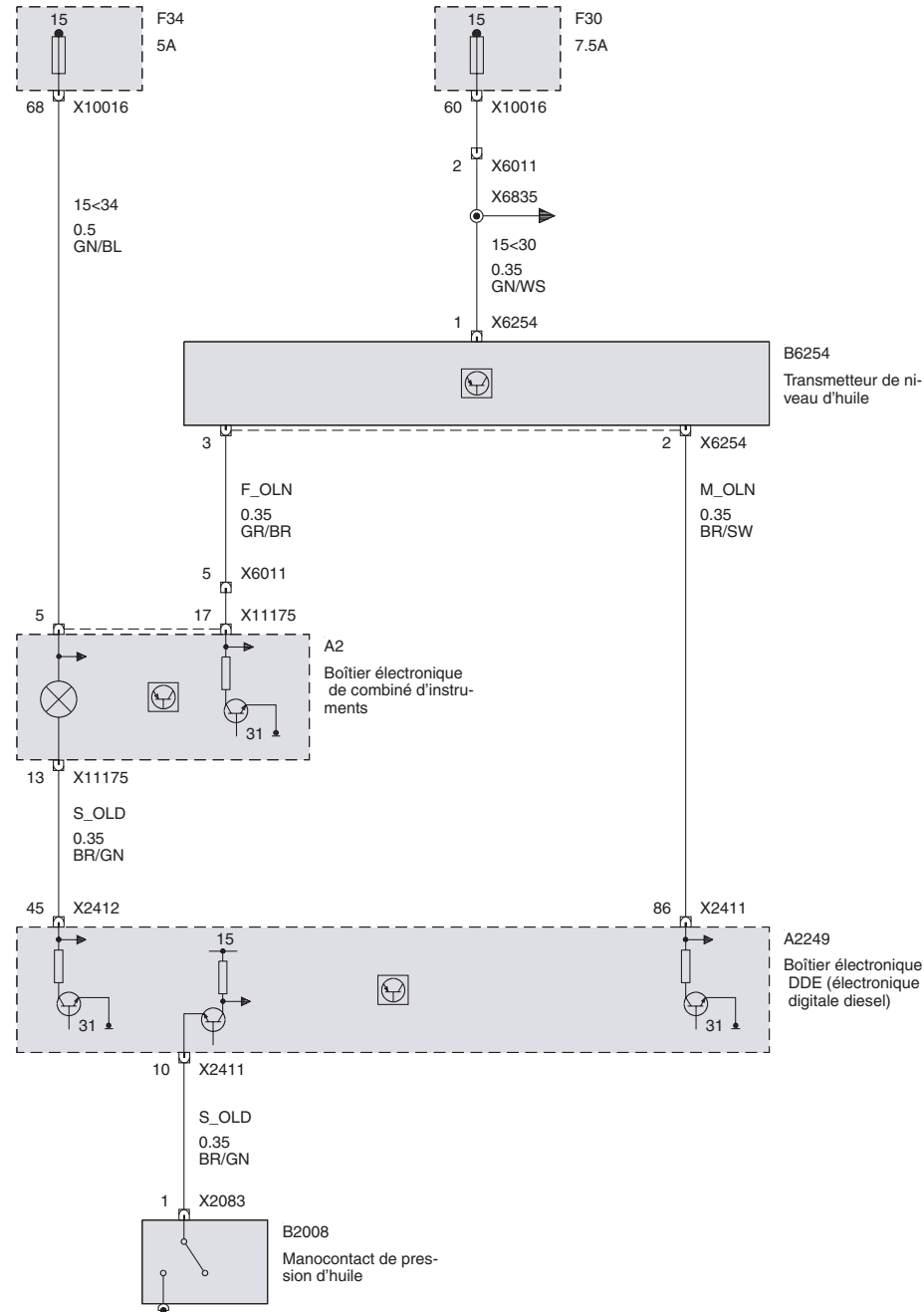

Niveau d'huile (DME Electronique moteur MS43)

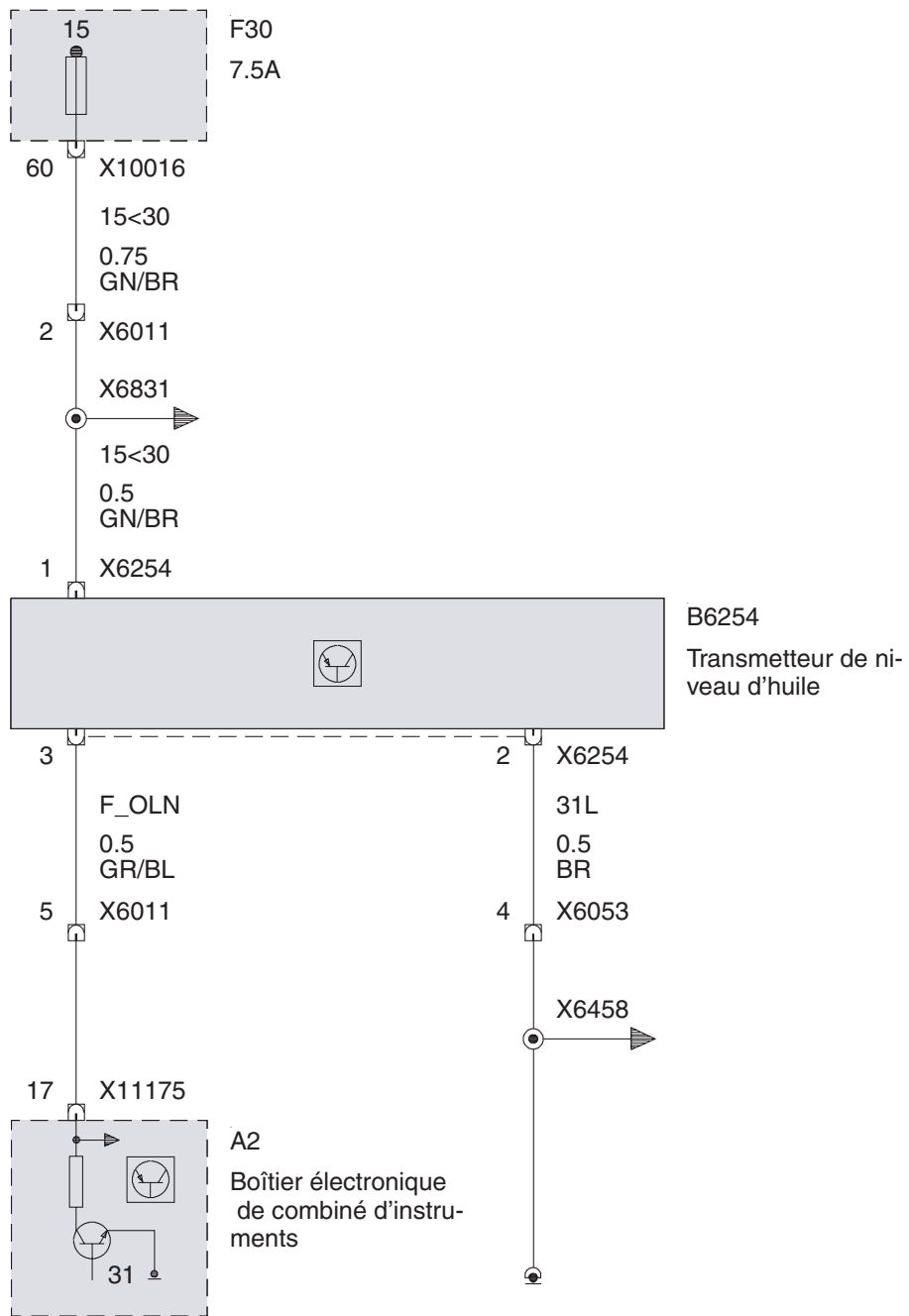



Niveau d'huile (DME Electronique moteur ME9)

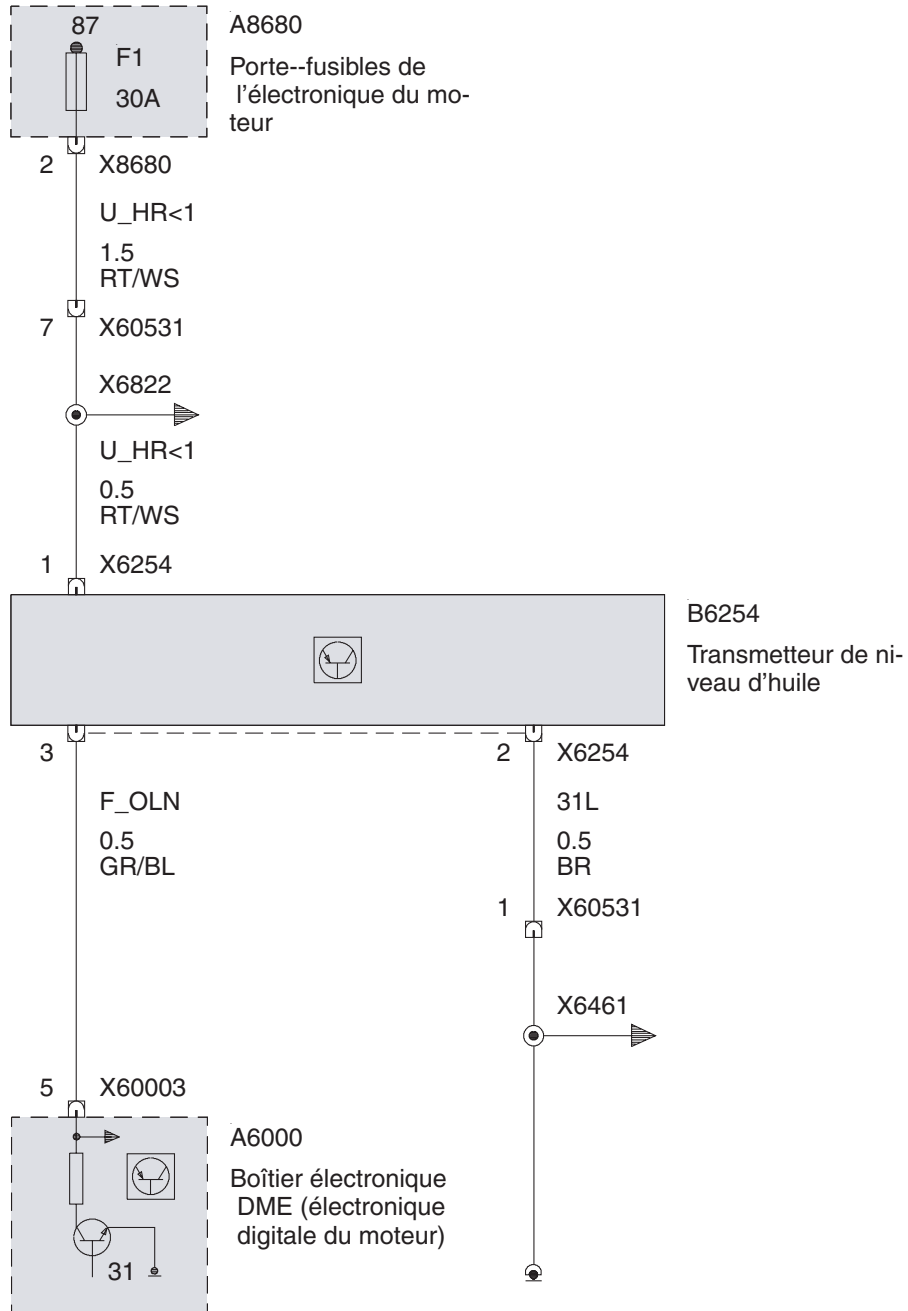

Alerte d'oubli de bouclage de ceinture, Contacteur de ceinture de sécurité côté conducteur

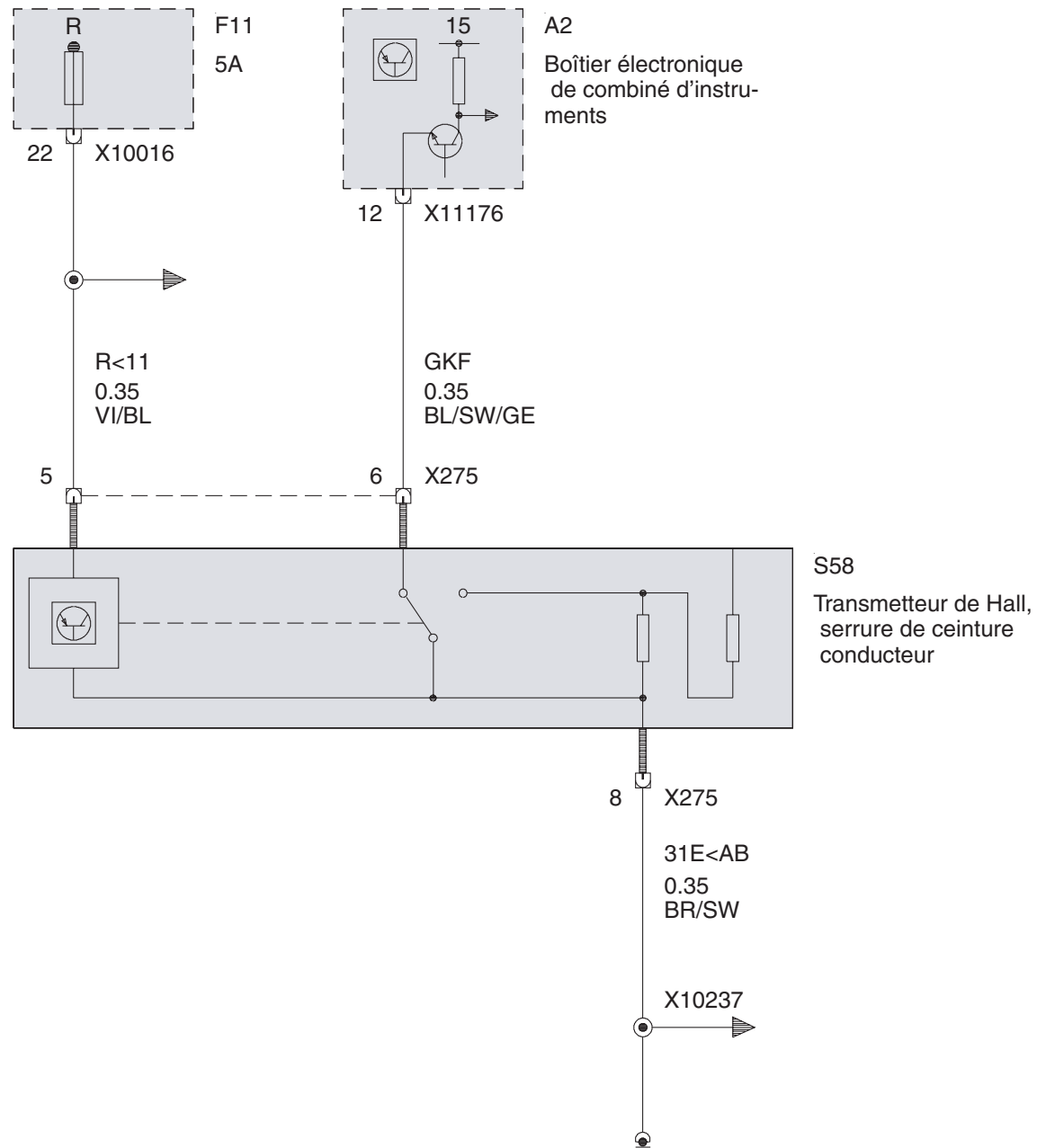

Témoin de frein de stationnement, niveau de liquide de frein

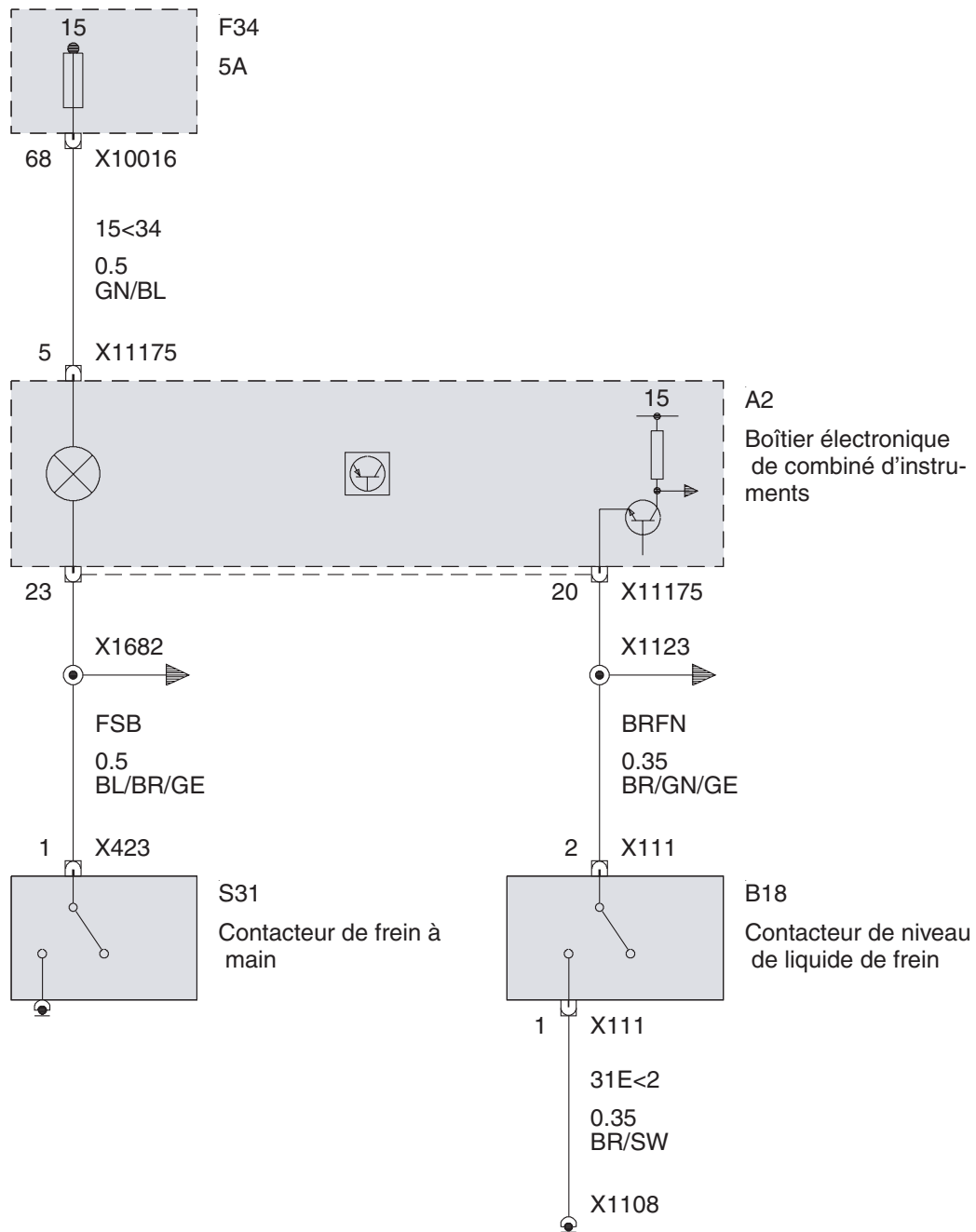

## Témoin d'usure de plaquettes de frein

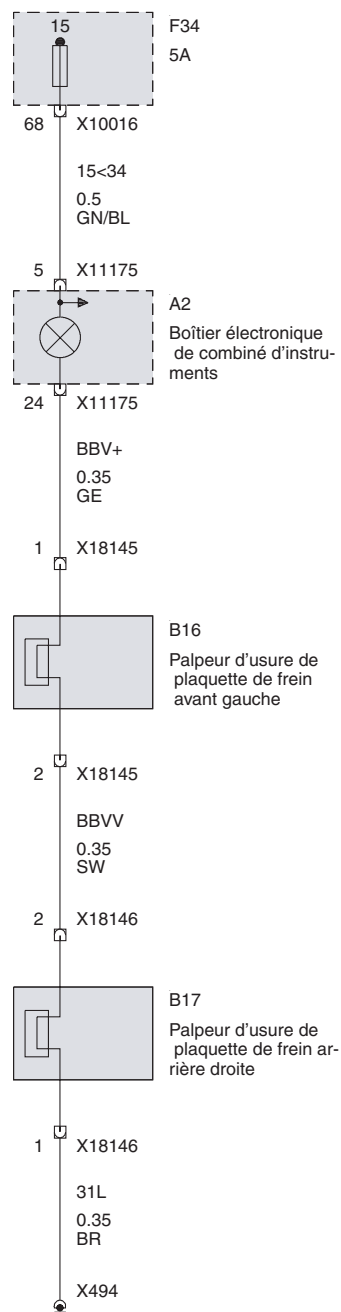

Niveau d'eau de lavage

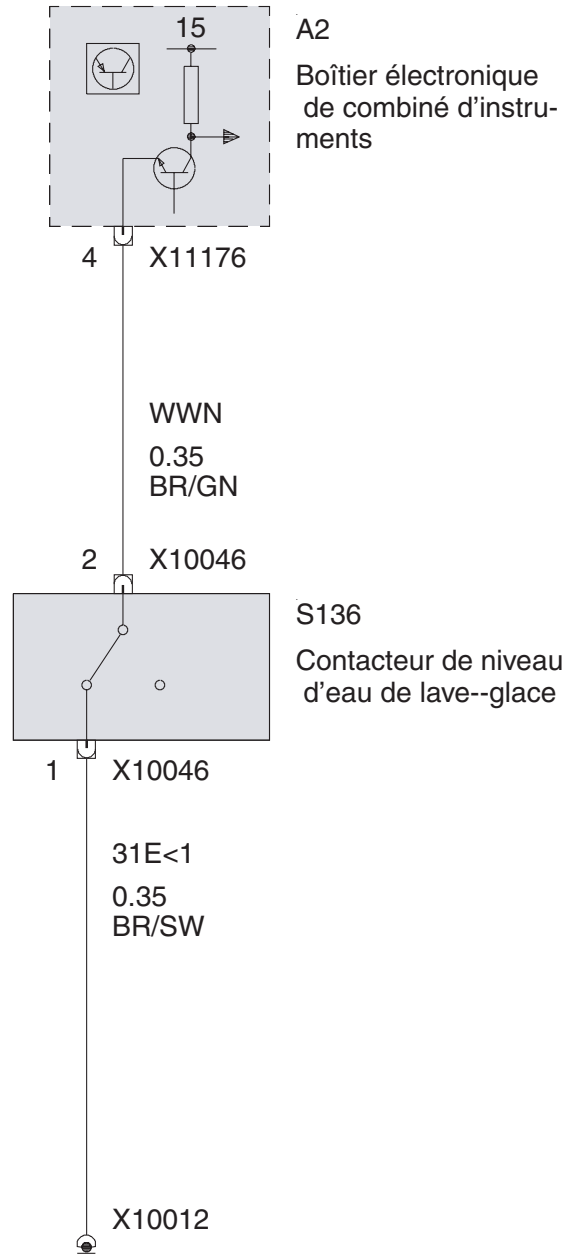

Gong

Gong (sans SMG Boîte "M" séquentielle)

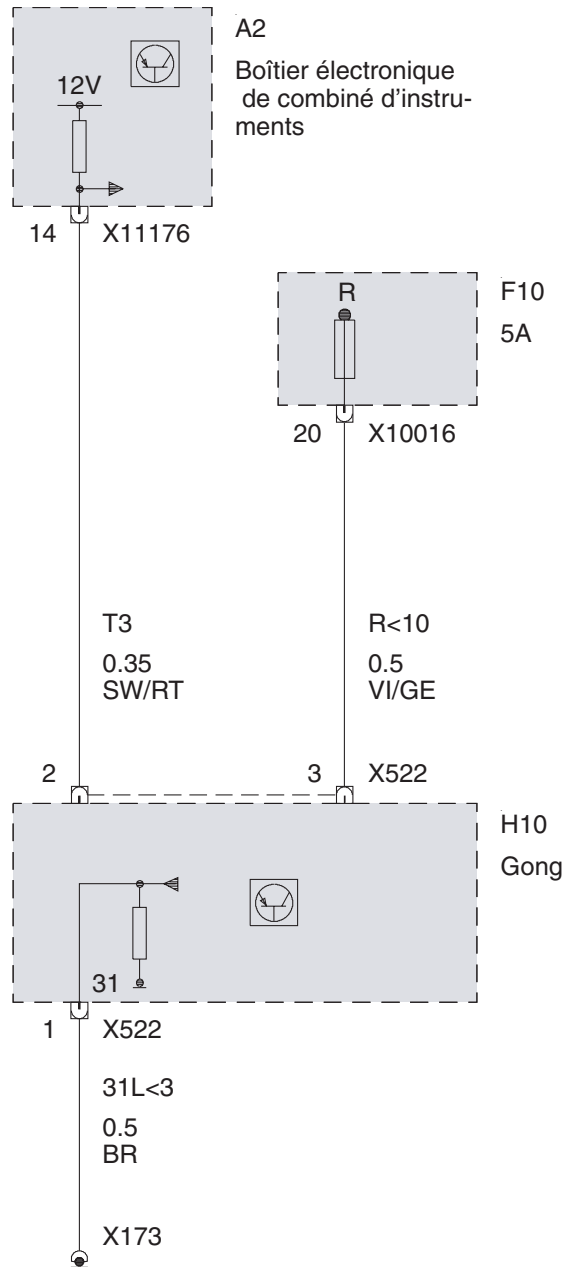

Gong (SMG Boîte "M" séquentielle à partir de 2001\_09 jusque 2002\_09)

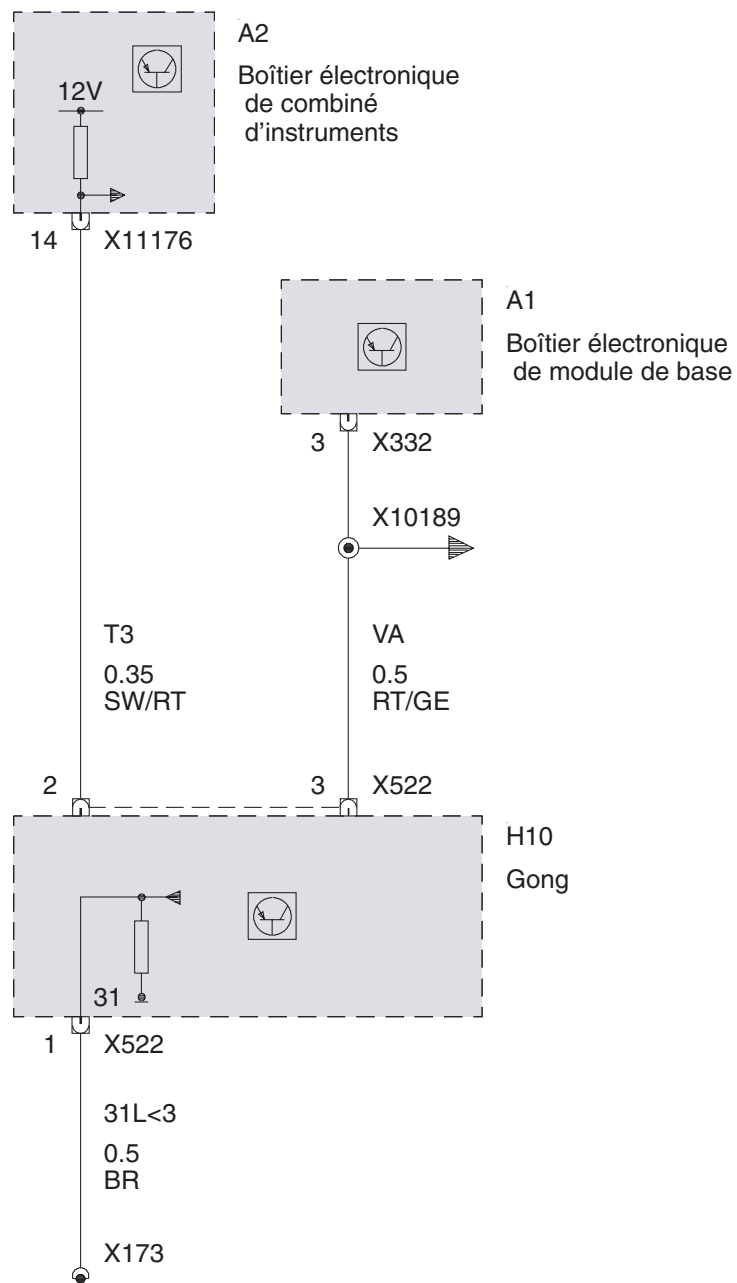

Gong (SMG Boîte "M" séquentielle à partir de 2002\_09)

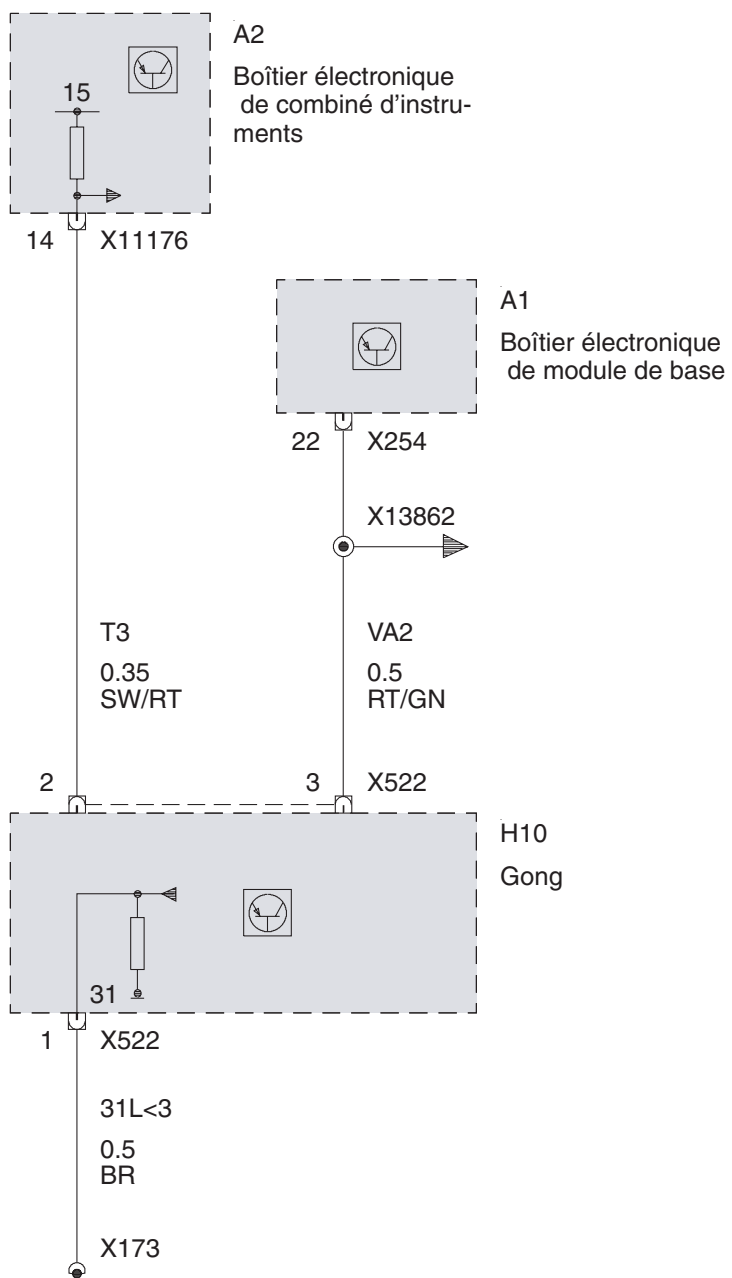



Ordinateur de bord (Vitesse et consommation moyenne, portée)

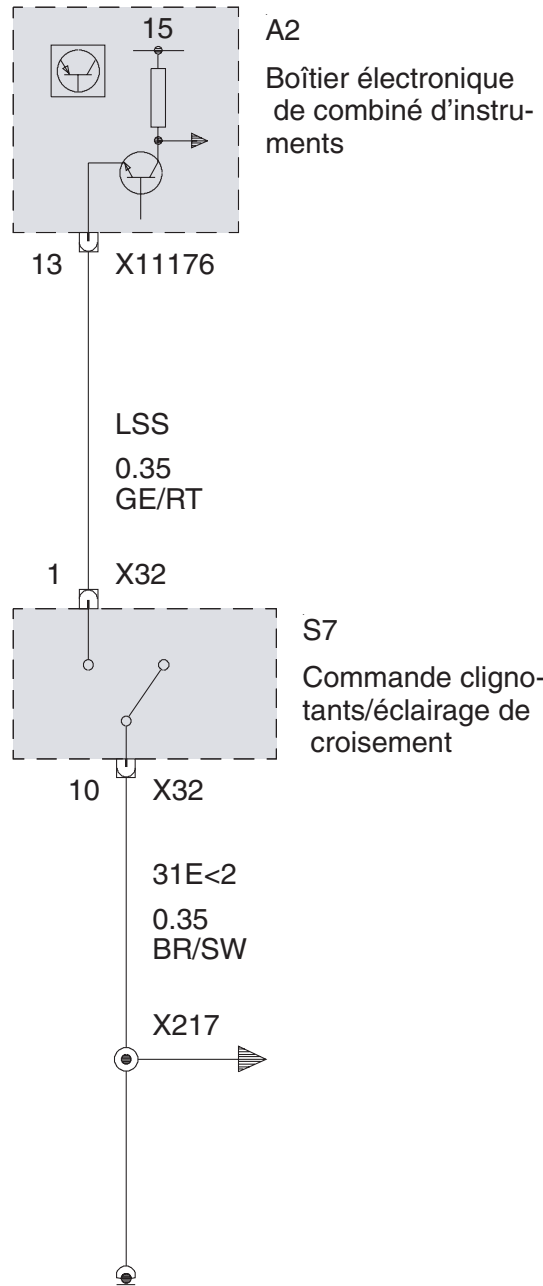

Signal de sortie A de tachymètre

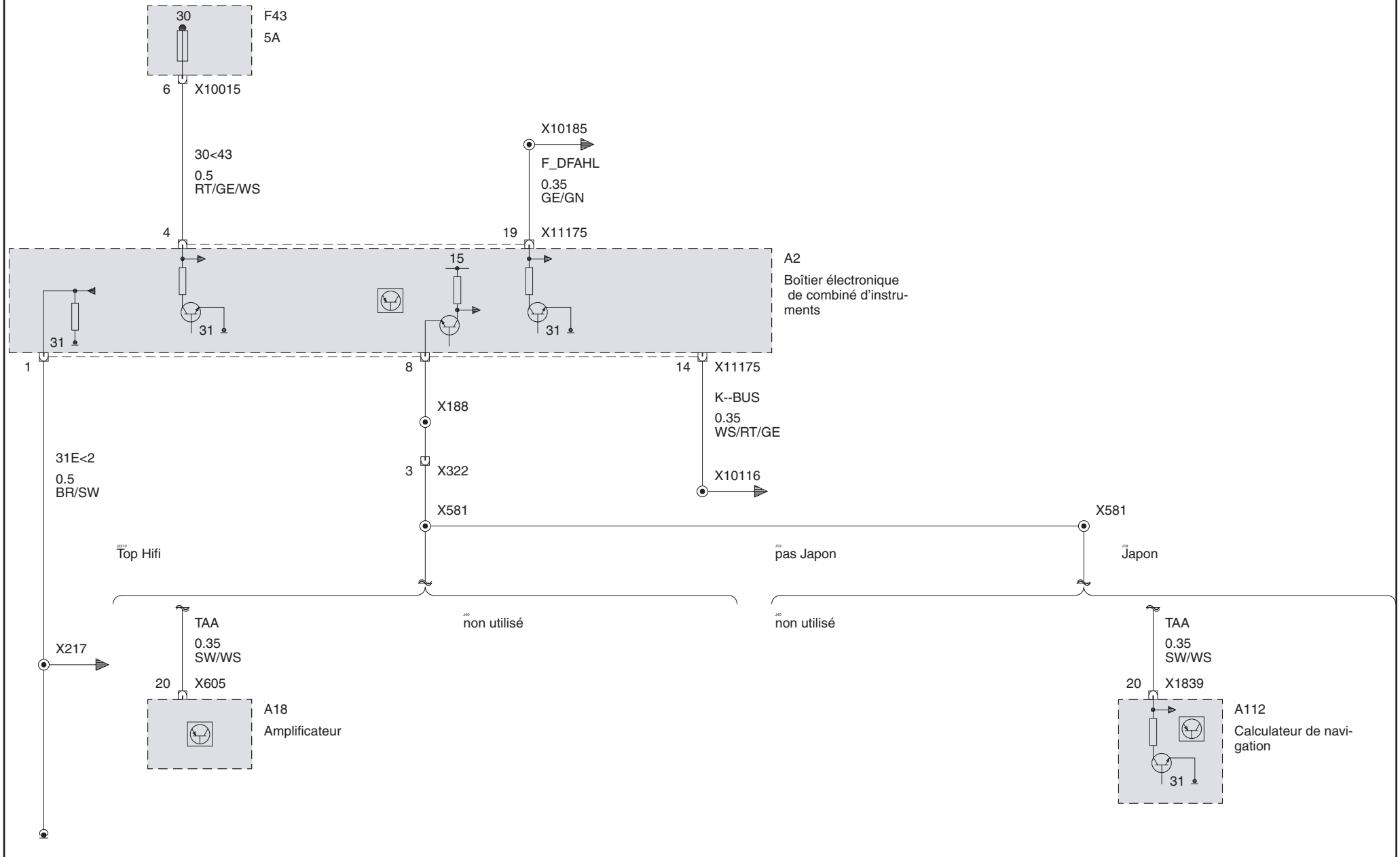

**Alimentation combiné d'instruments**  
Alimentation/interface (à partir de 2000\_06 jusque 2002\_09)

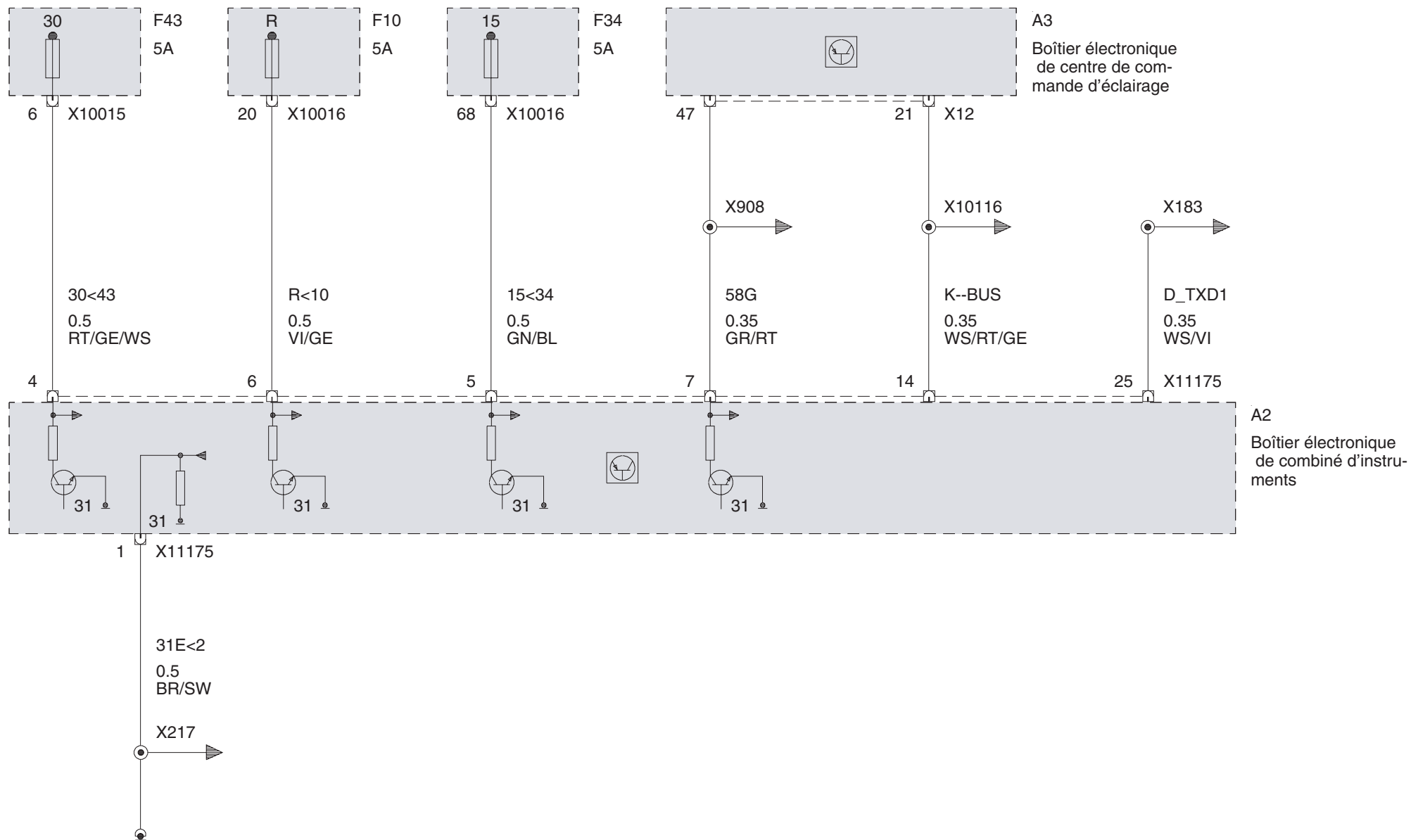

Alimentation/interface (à partir de 2002\_09)

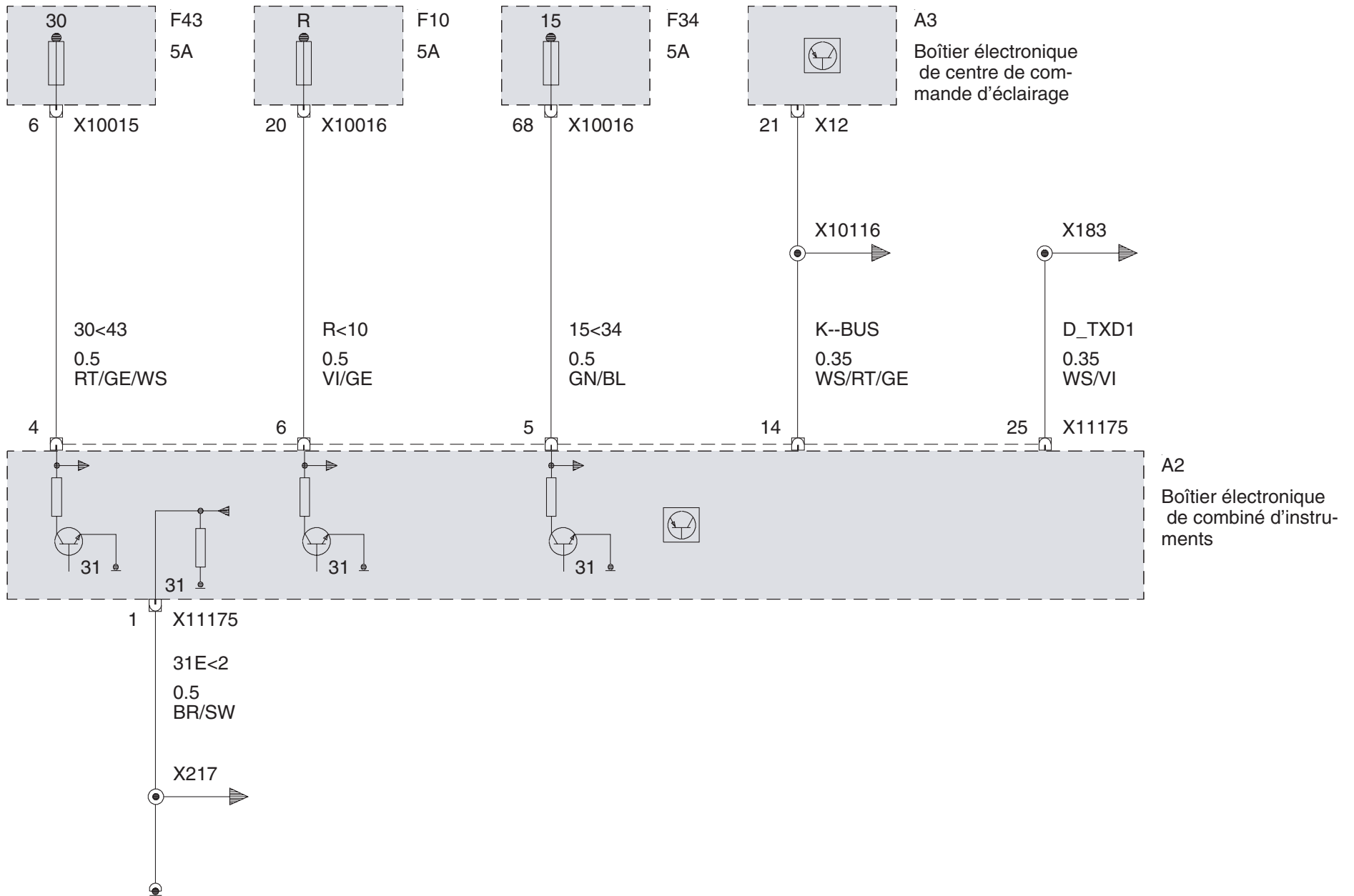

## Eclairage Eclairage (Berline sans Phare au xénon)

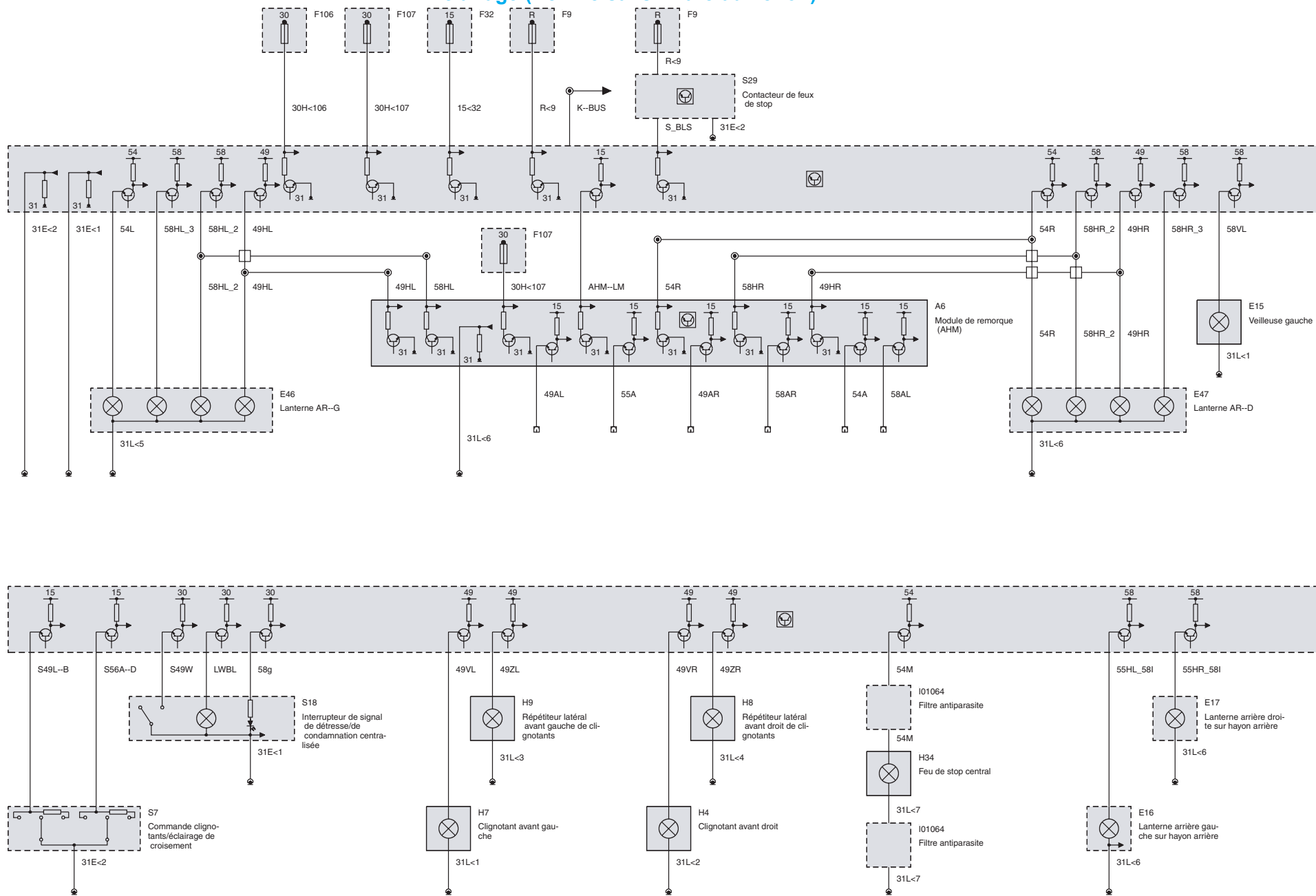

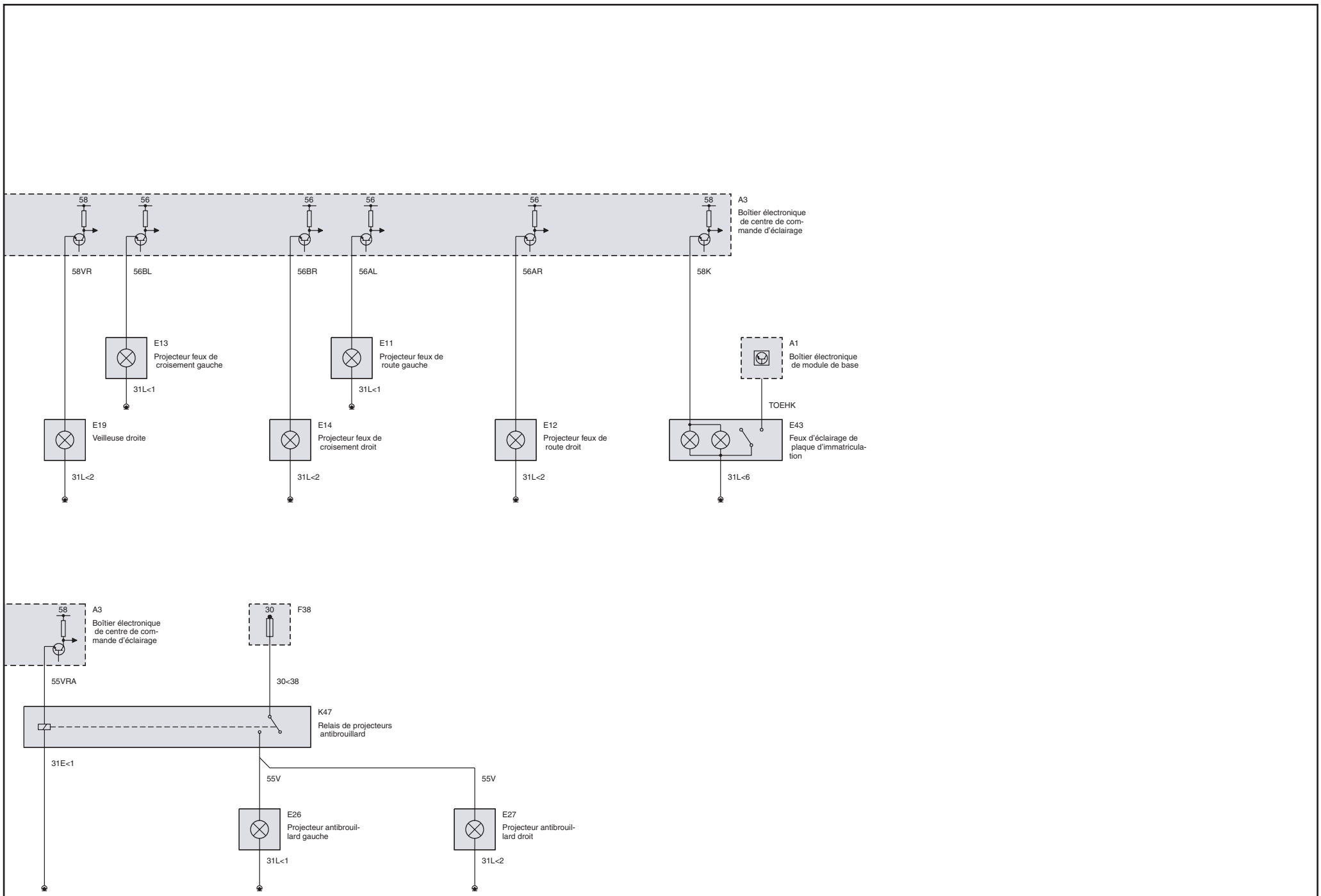

Eclairage (Berline avec Phare au xénon à partir de 2001\_09 jusqu'à 2003\_03)

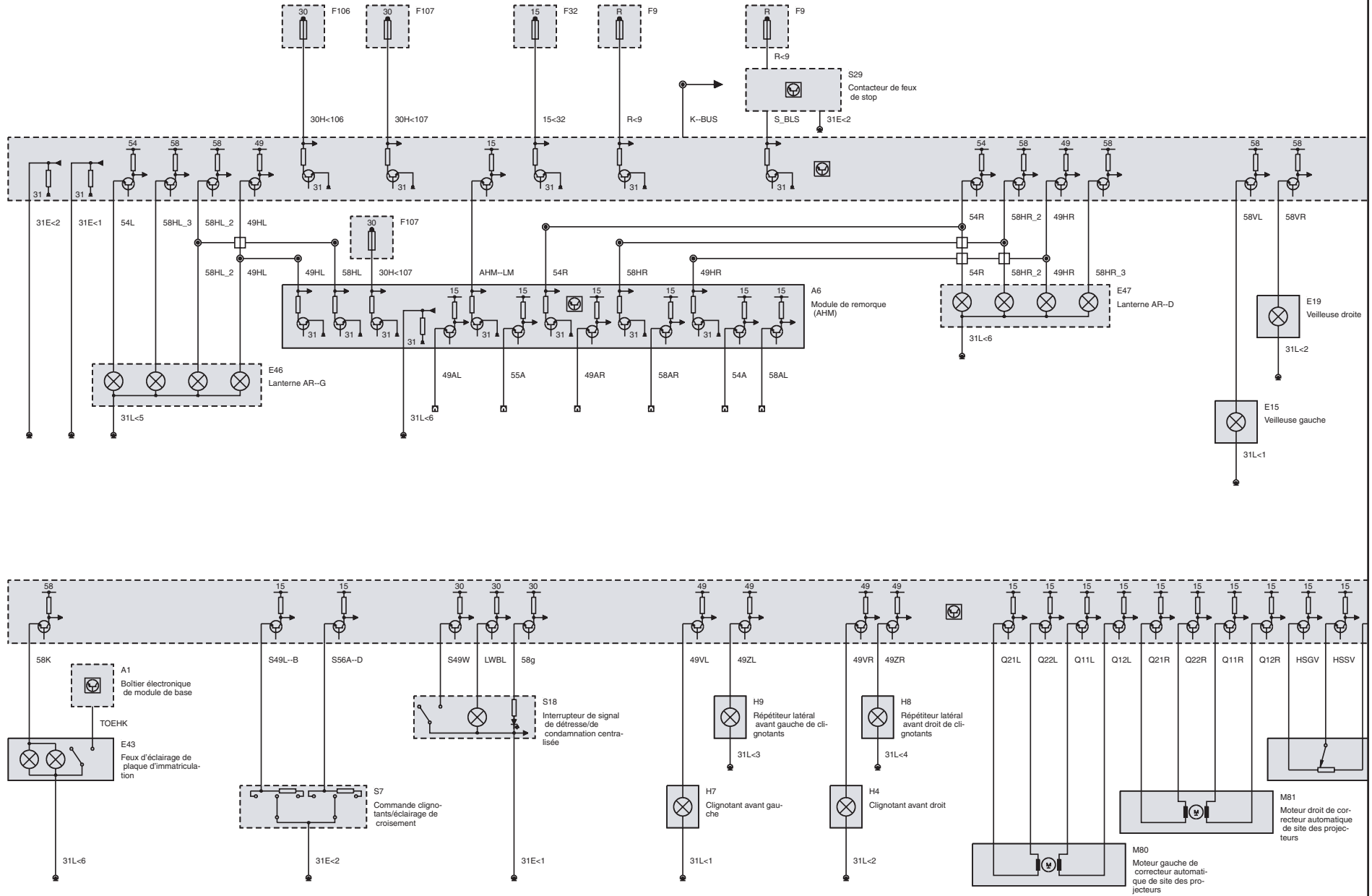

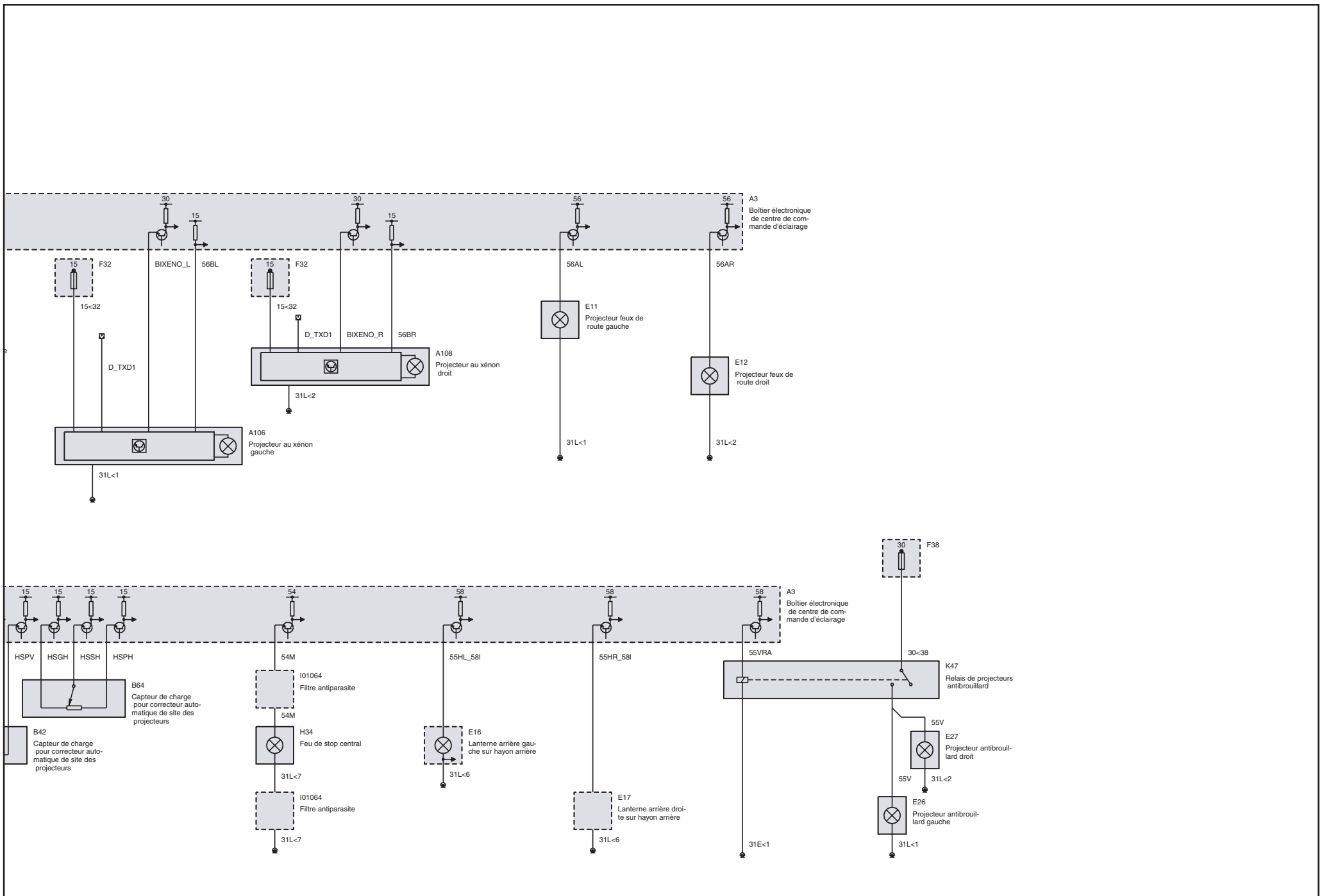



Eclairage (Berline avec Eclairage au xénon à partir de 2003\_03)

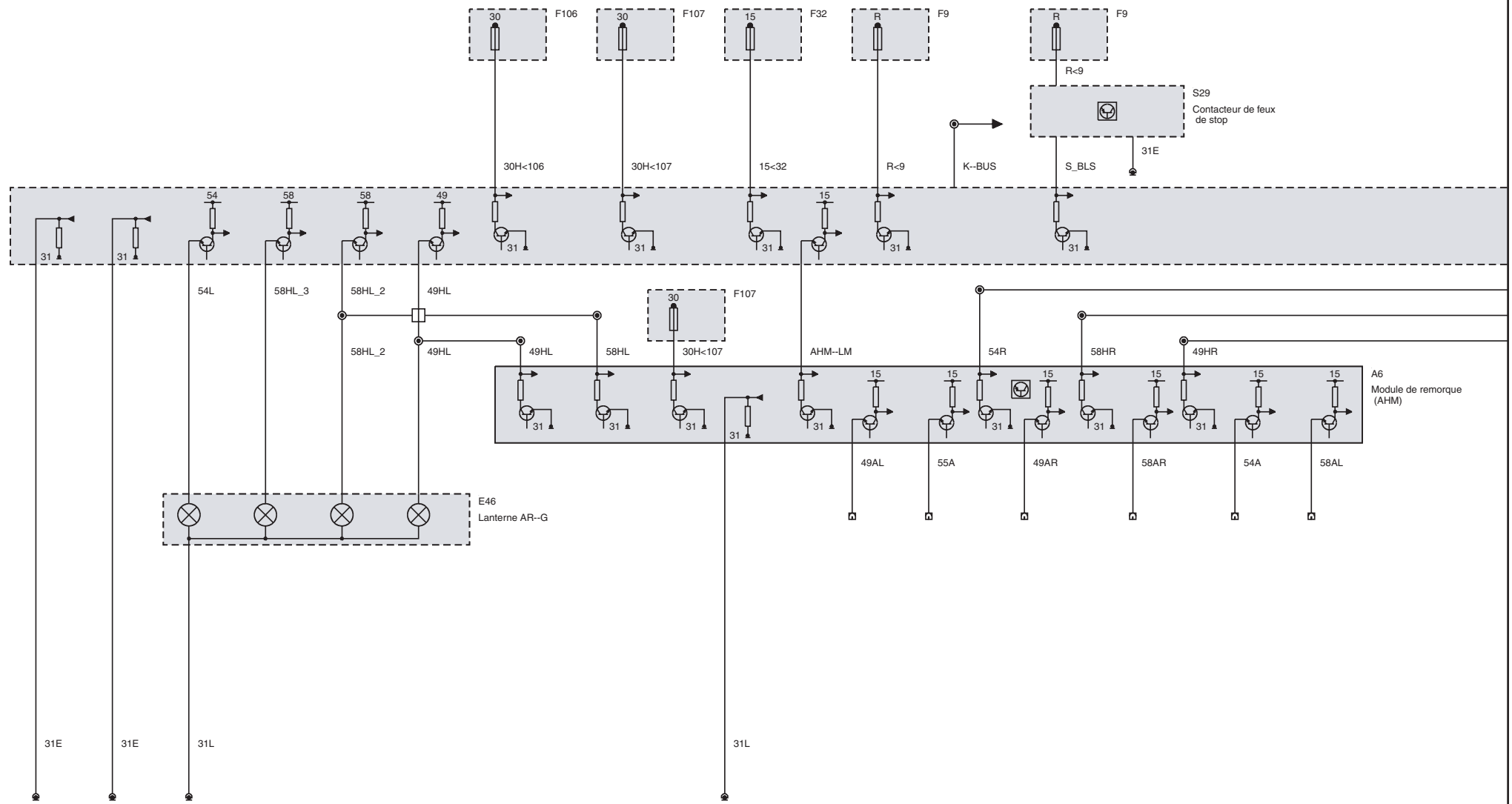

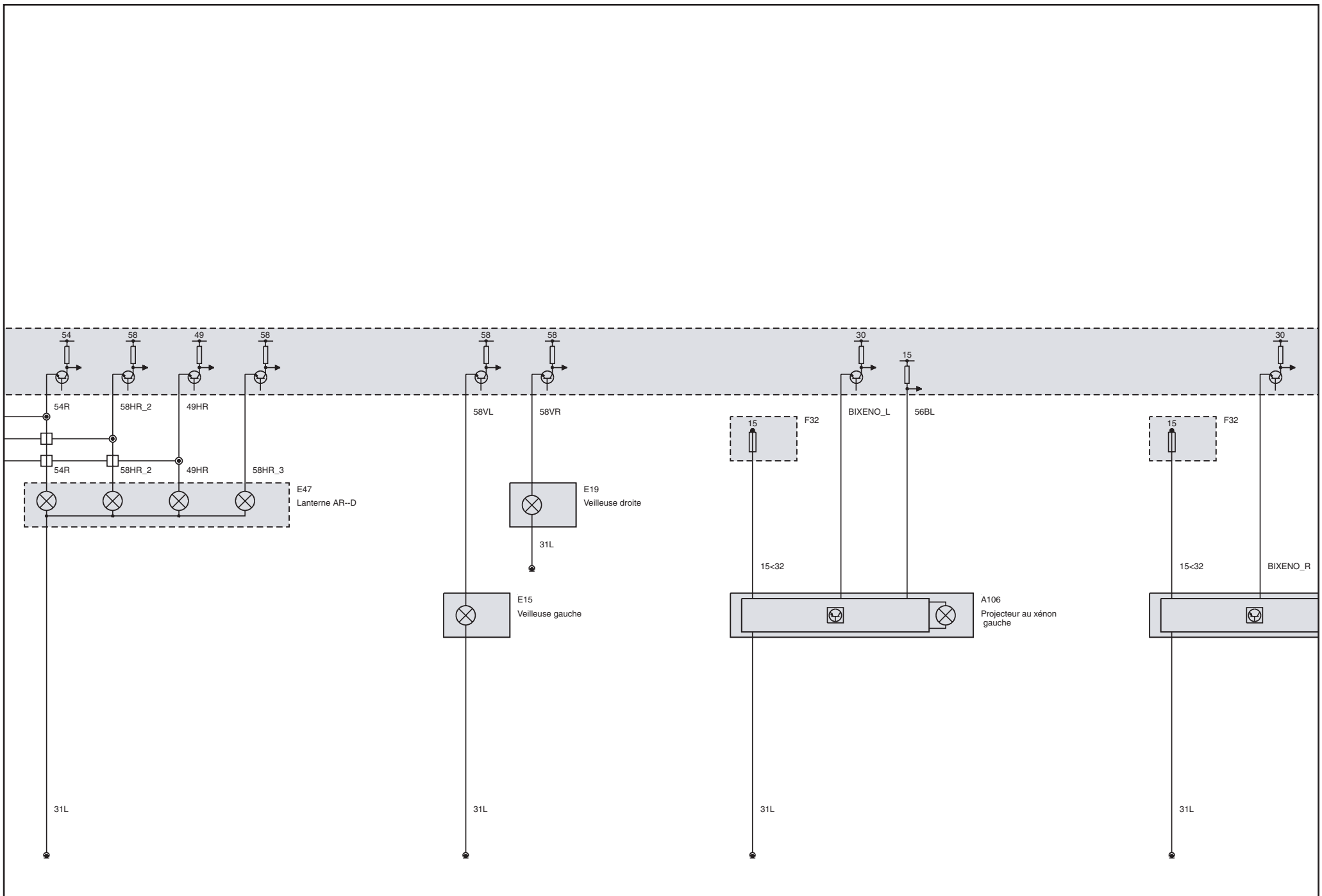

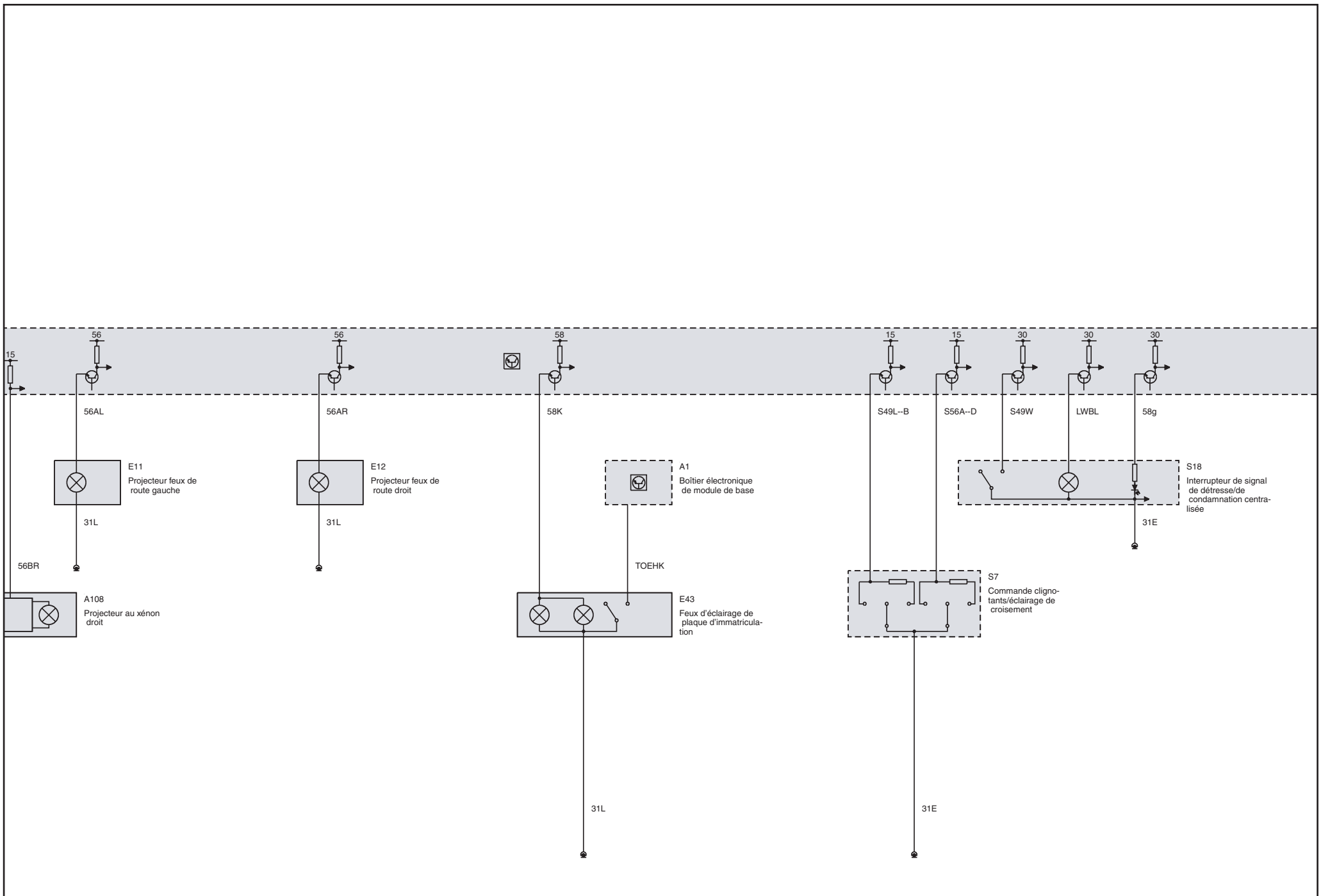

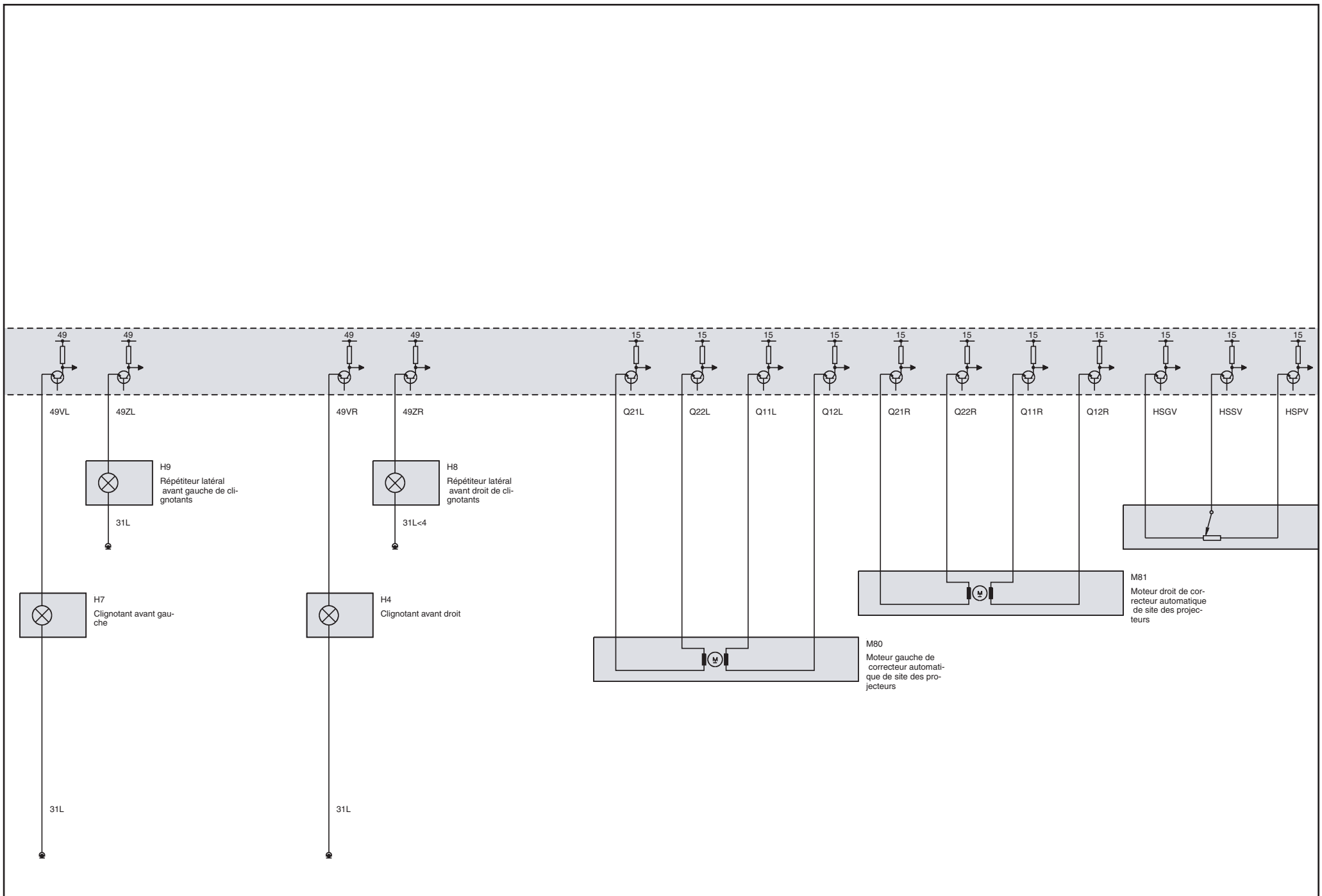

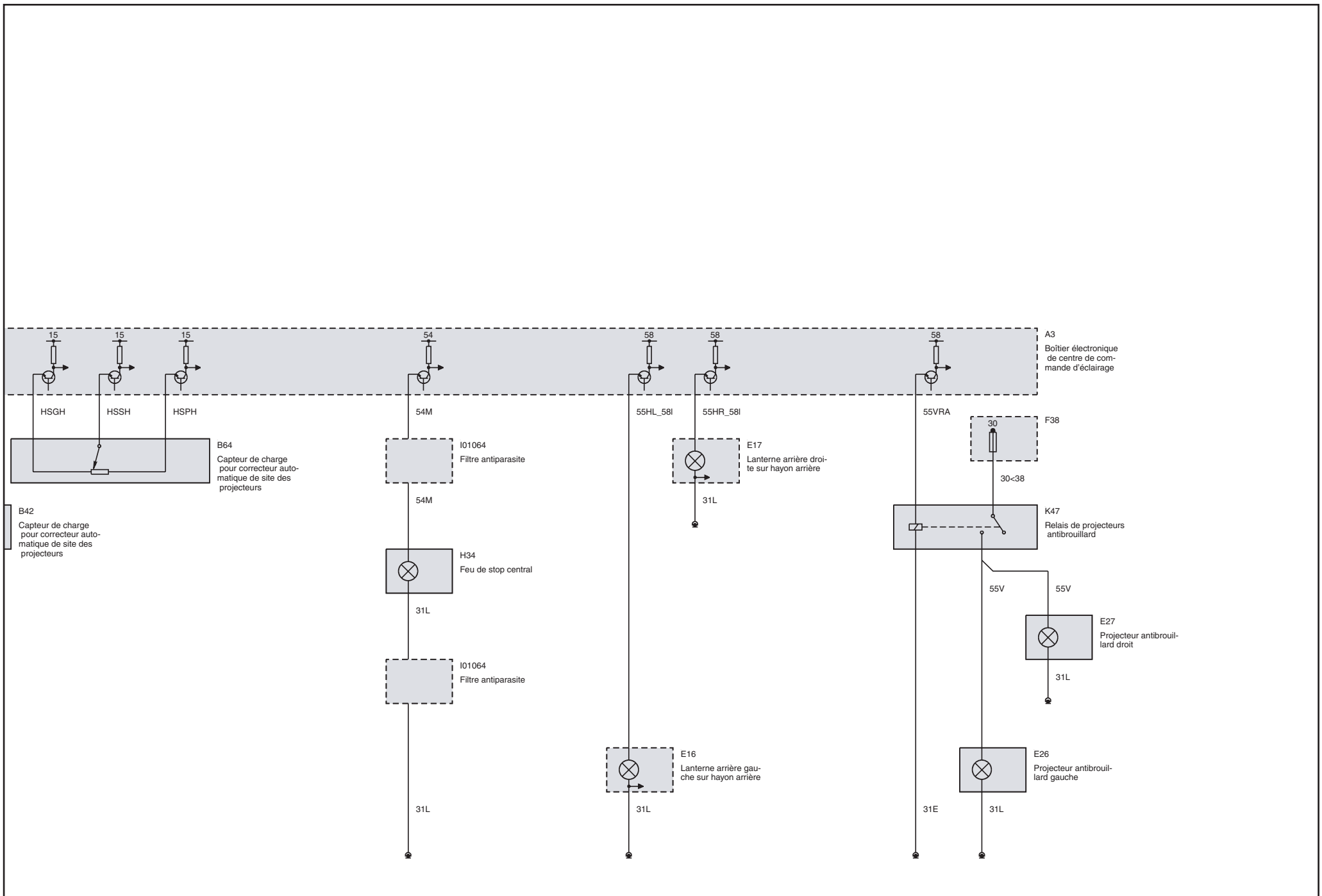

Eclairage (Touring ou Coupé ou Cabriolet sans Phare au xénon à partir de 2001\_09 jusque 2003\_03)

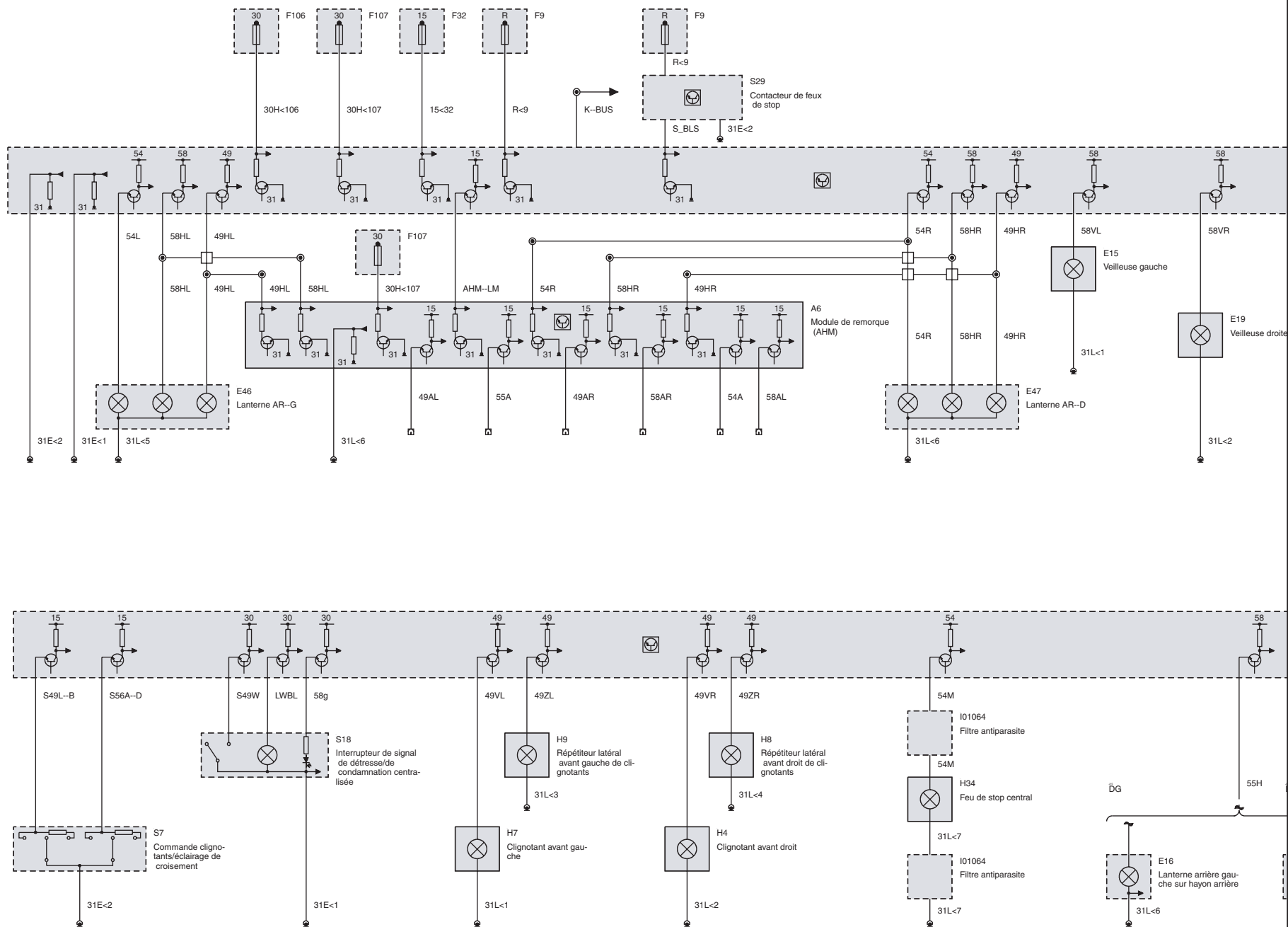

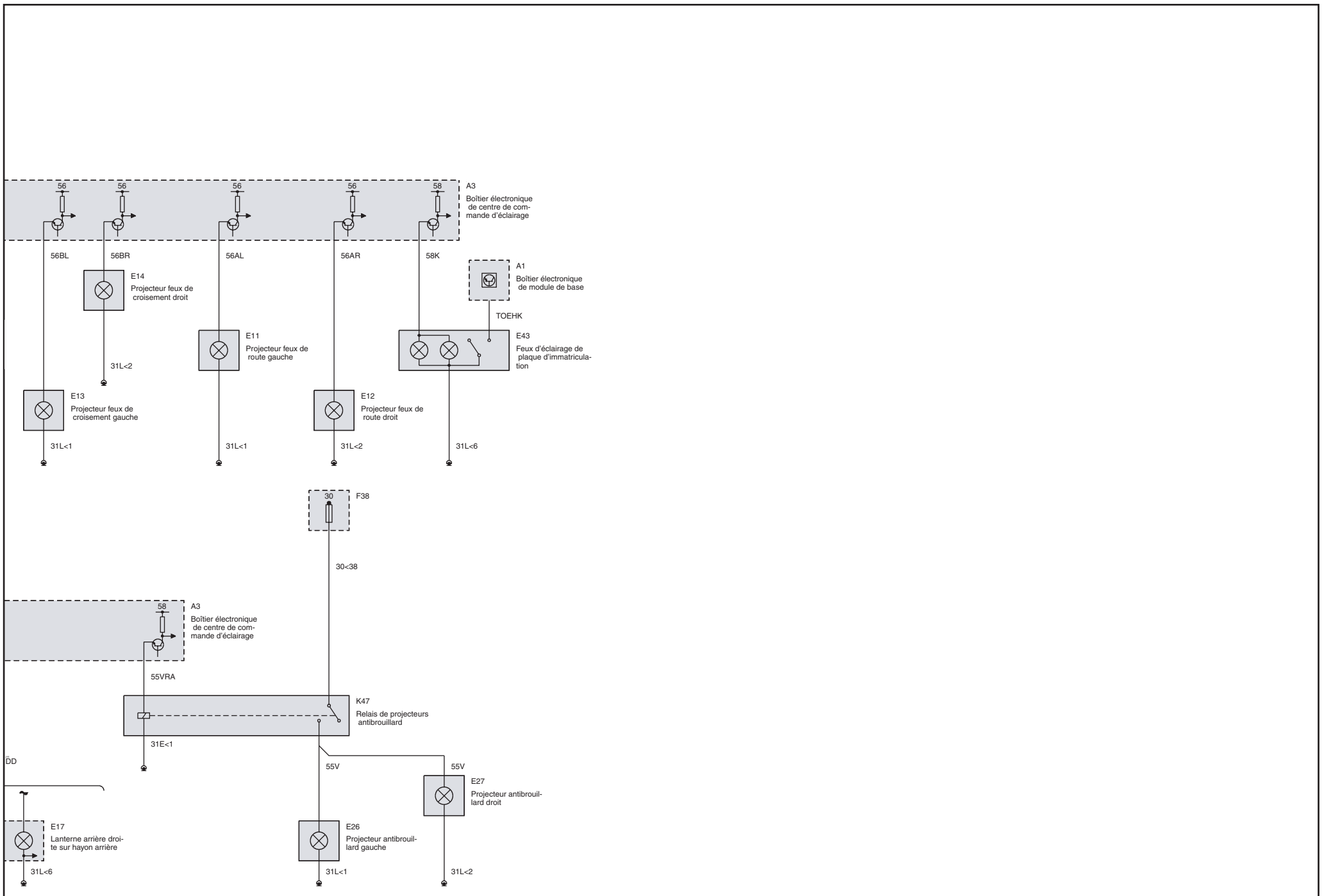

Eclairage (Touring ou Coupé ou Cabriolet avec Phare au xénon à partir de 2001\_09 jusque 2003\_03)

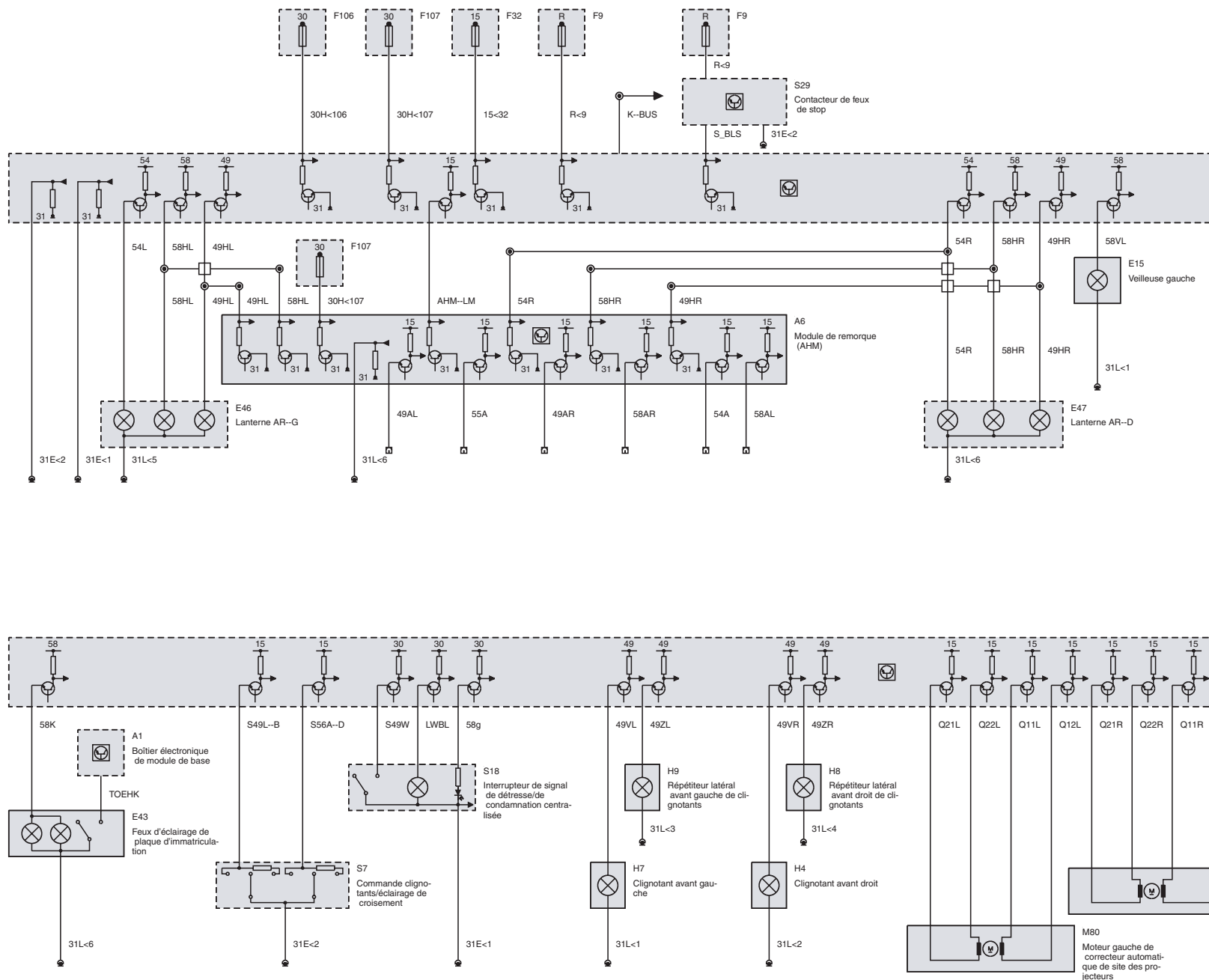



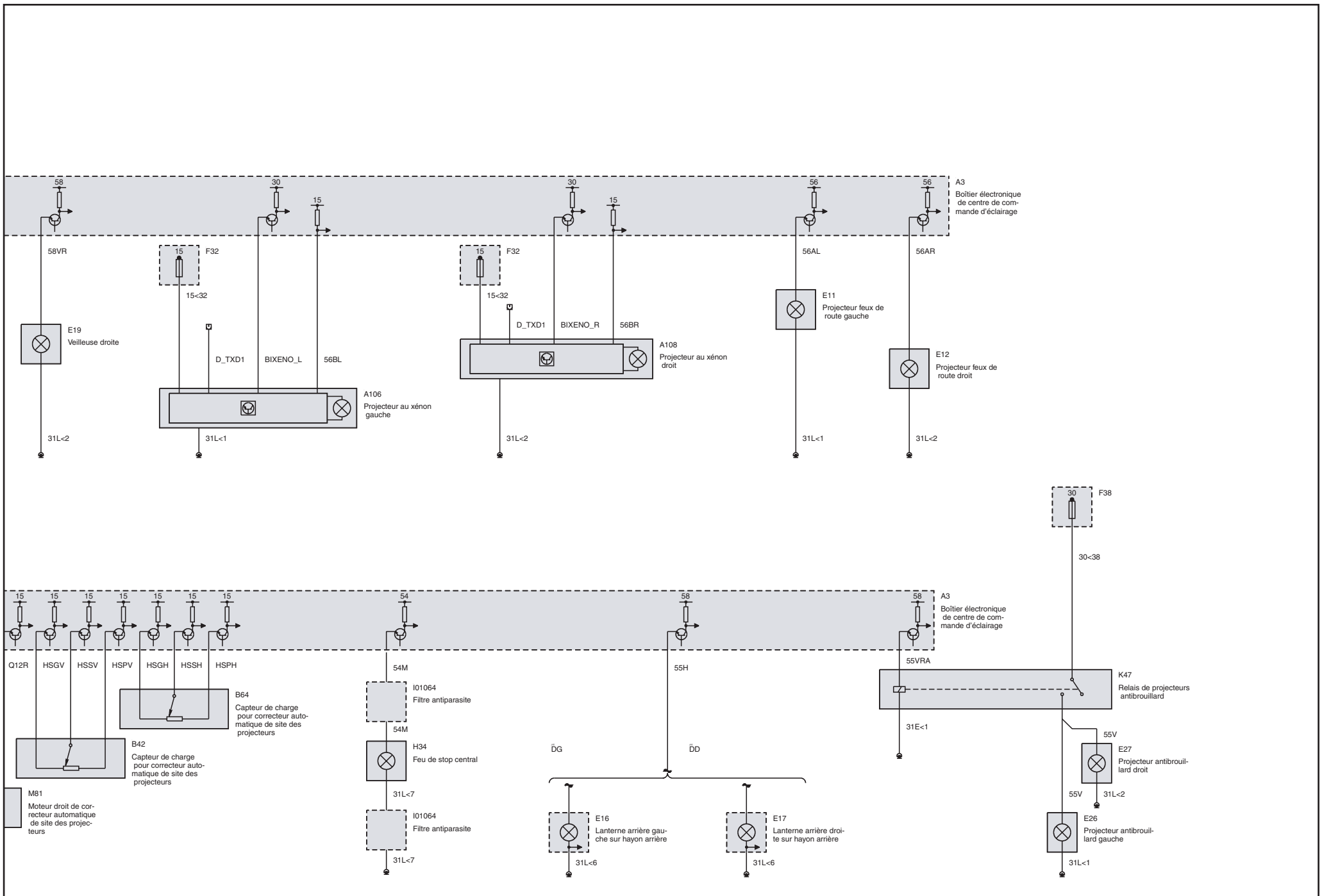

Eclairage (Touring sans Eclairage au xénon à partir de 2003\_03)

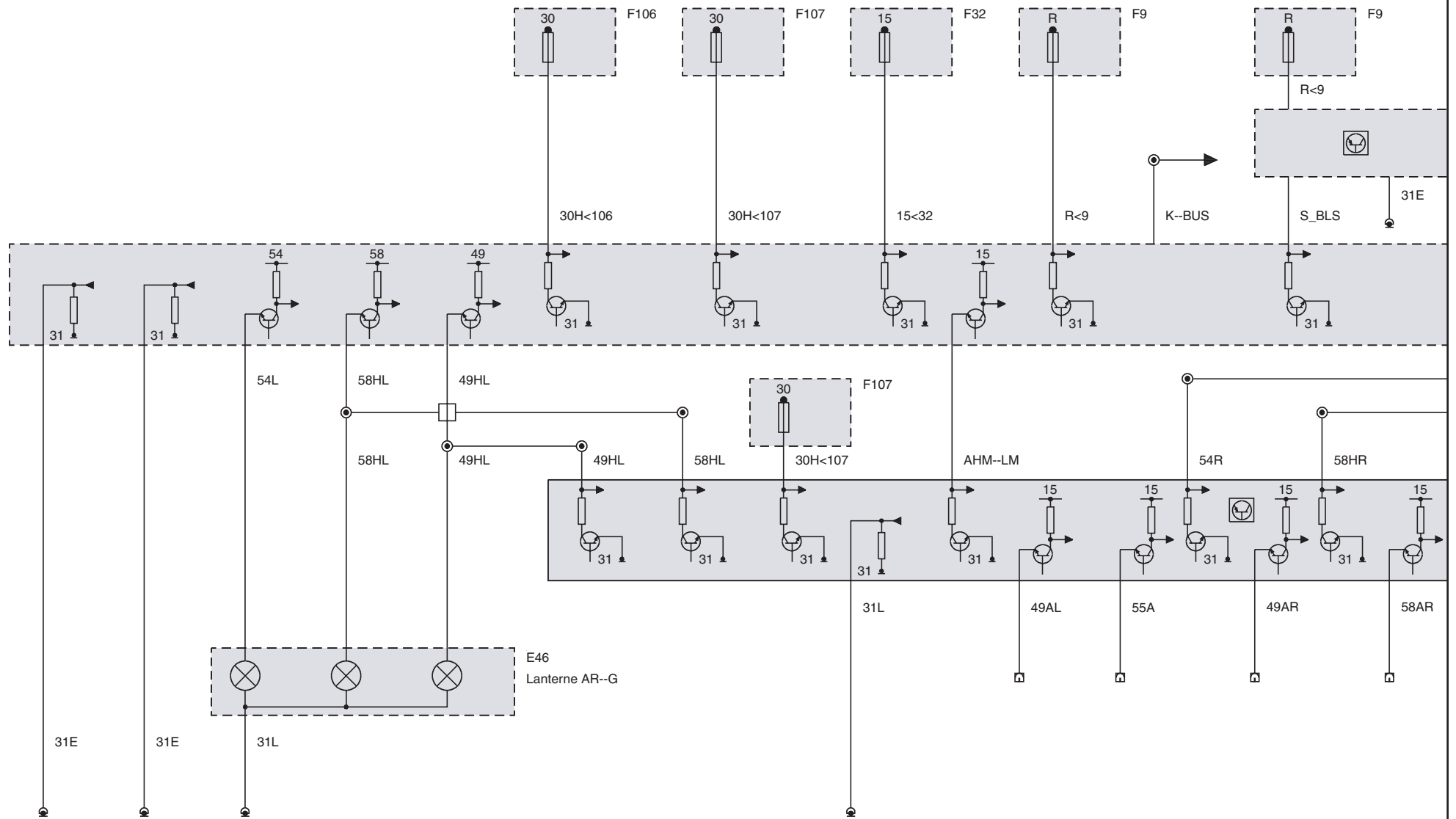

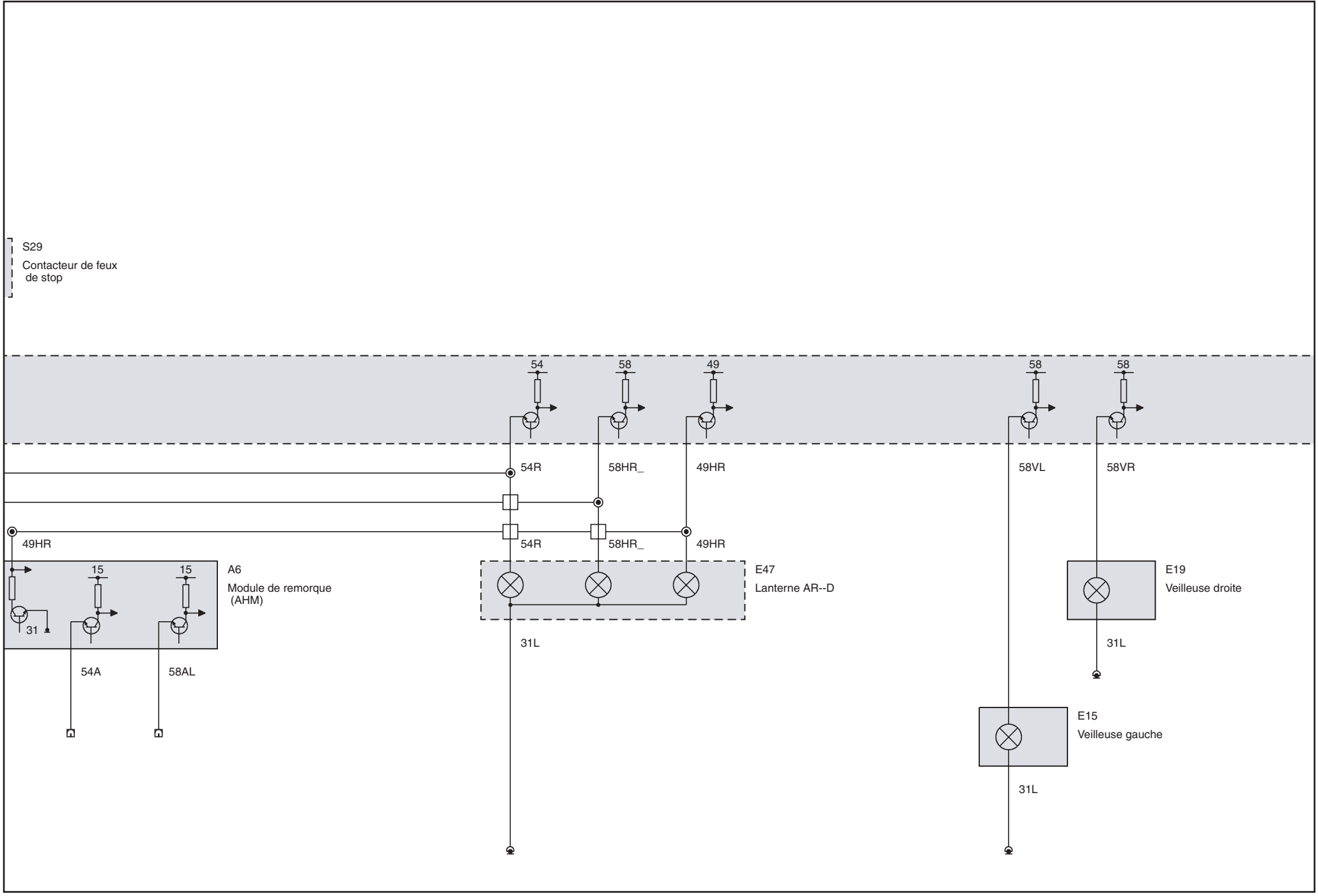

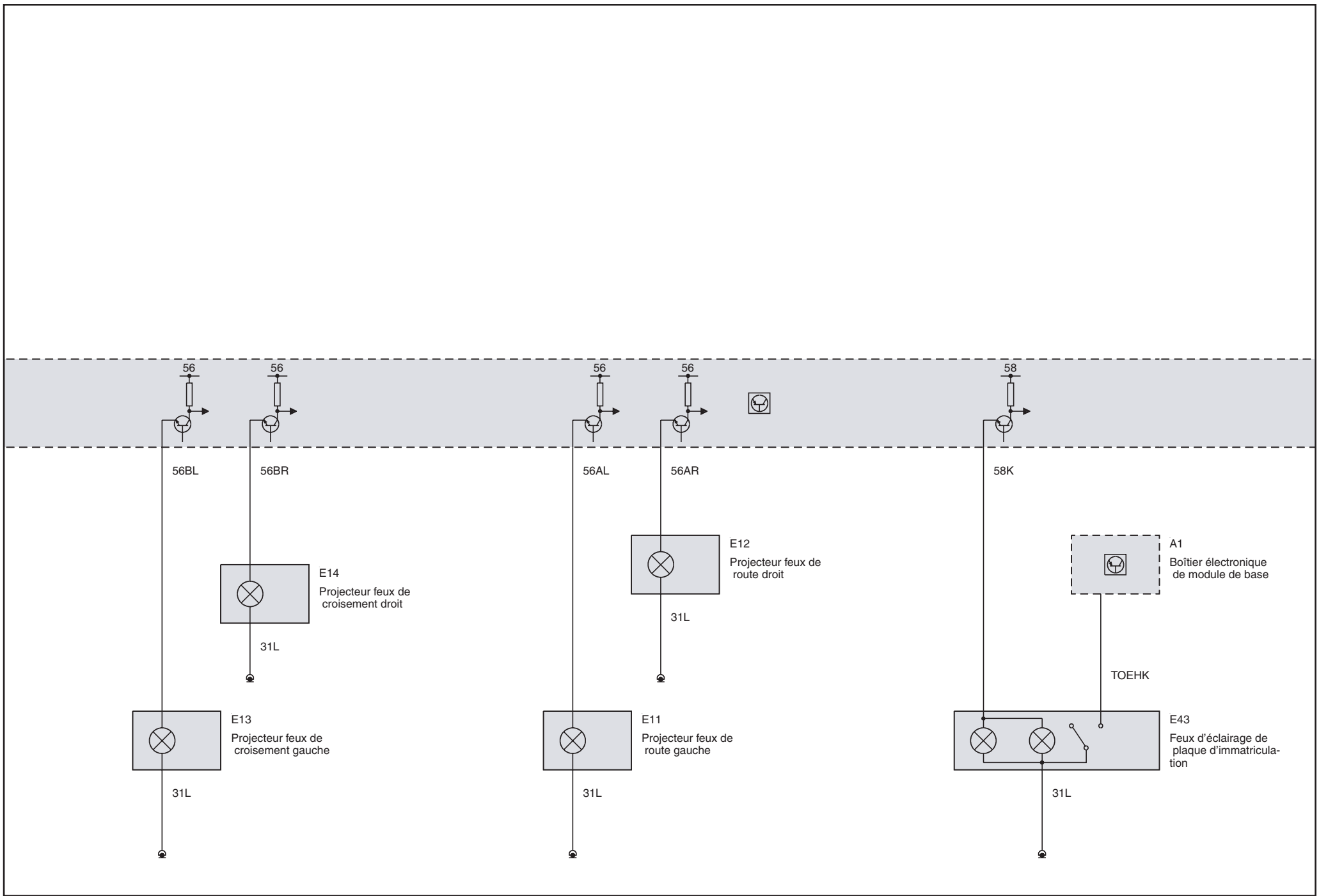

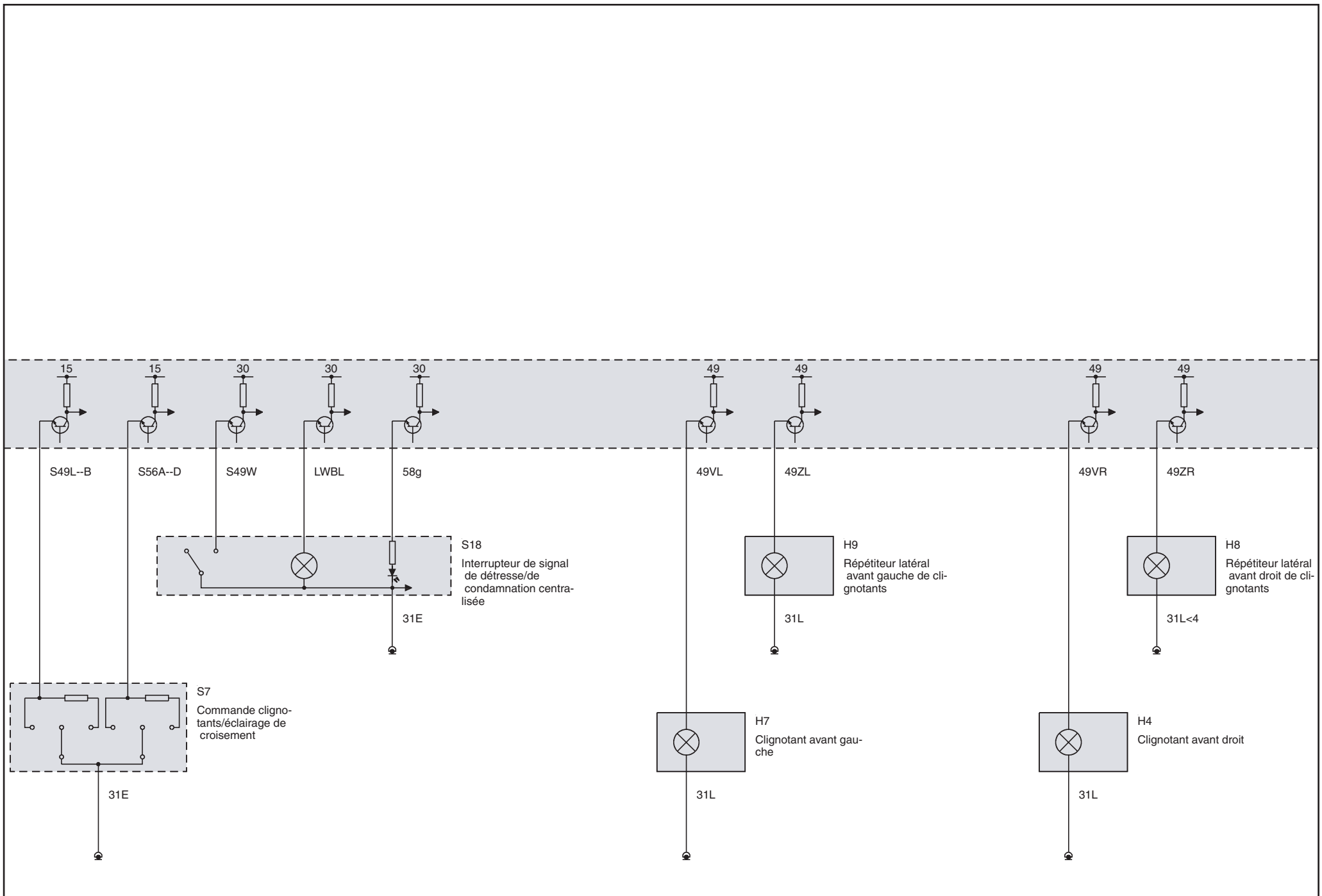

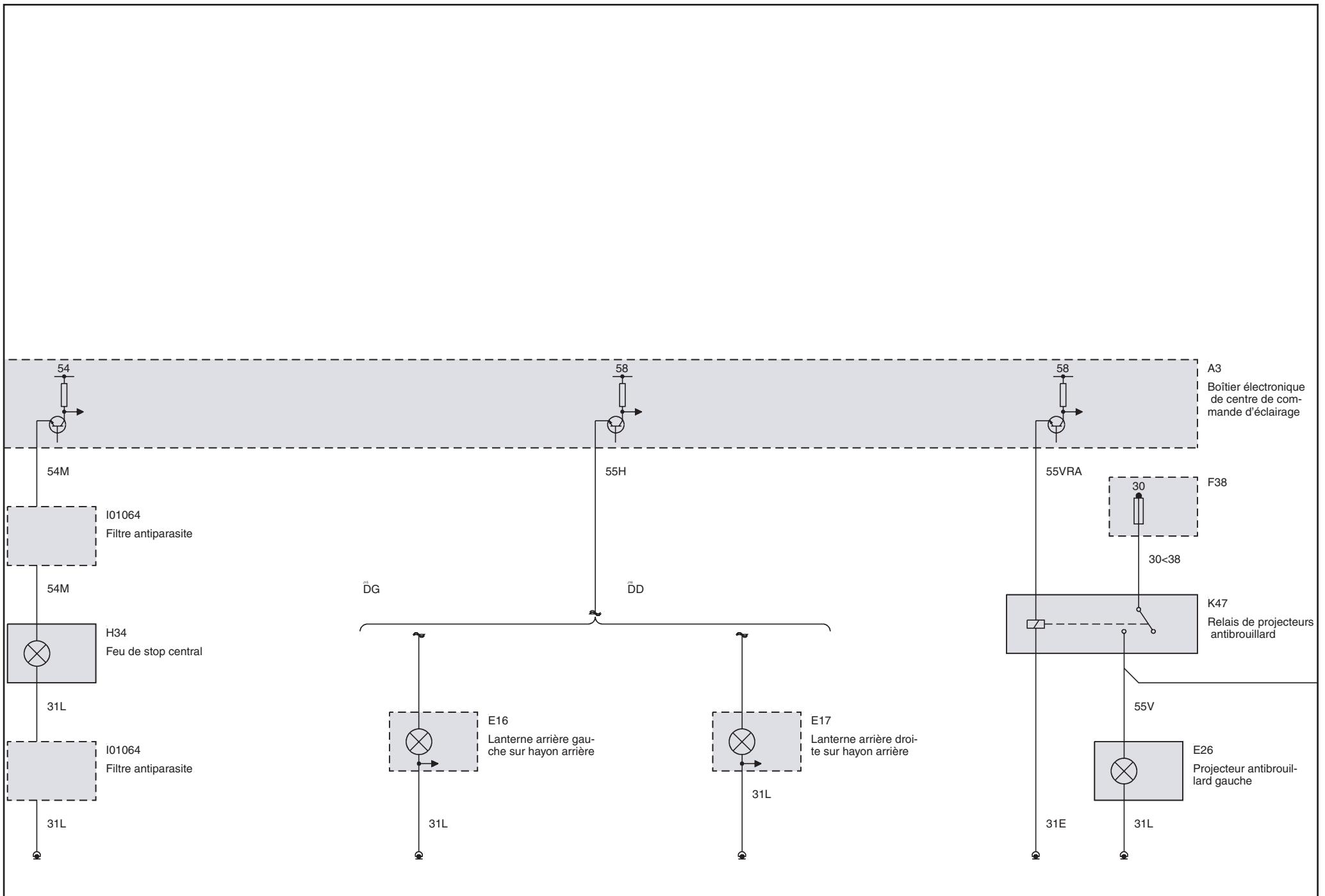

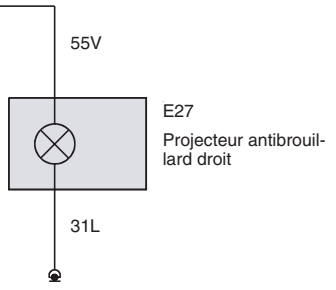
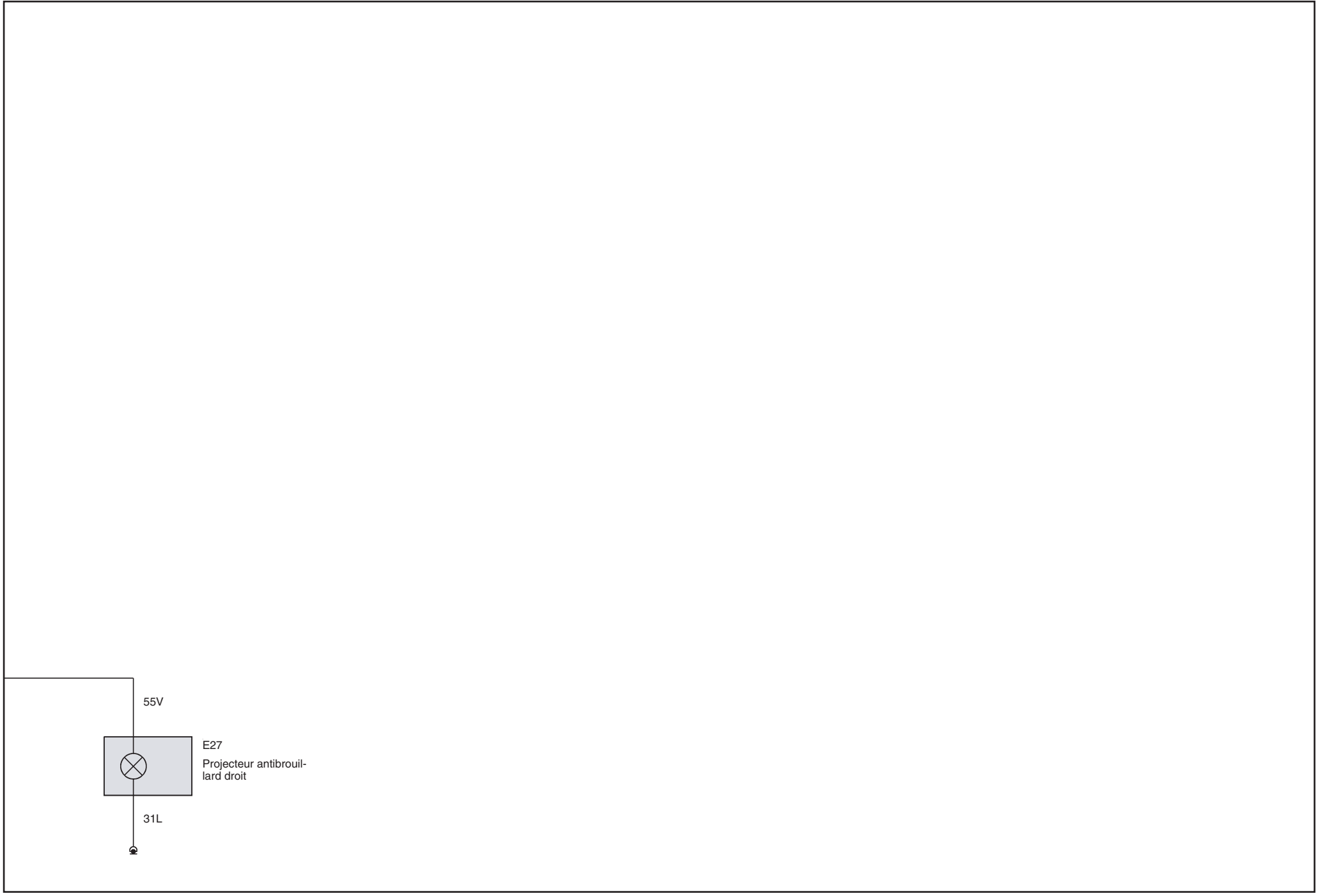

Eclairage (Touring avec Eclairage au xénon à partir de 2003\_03)

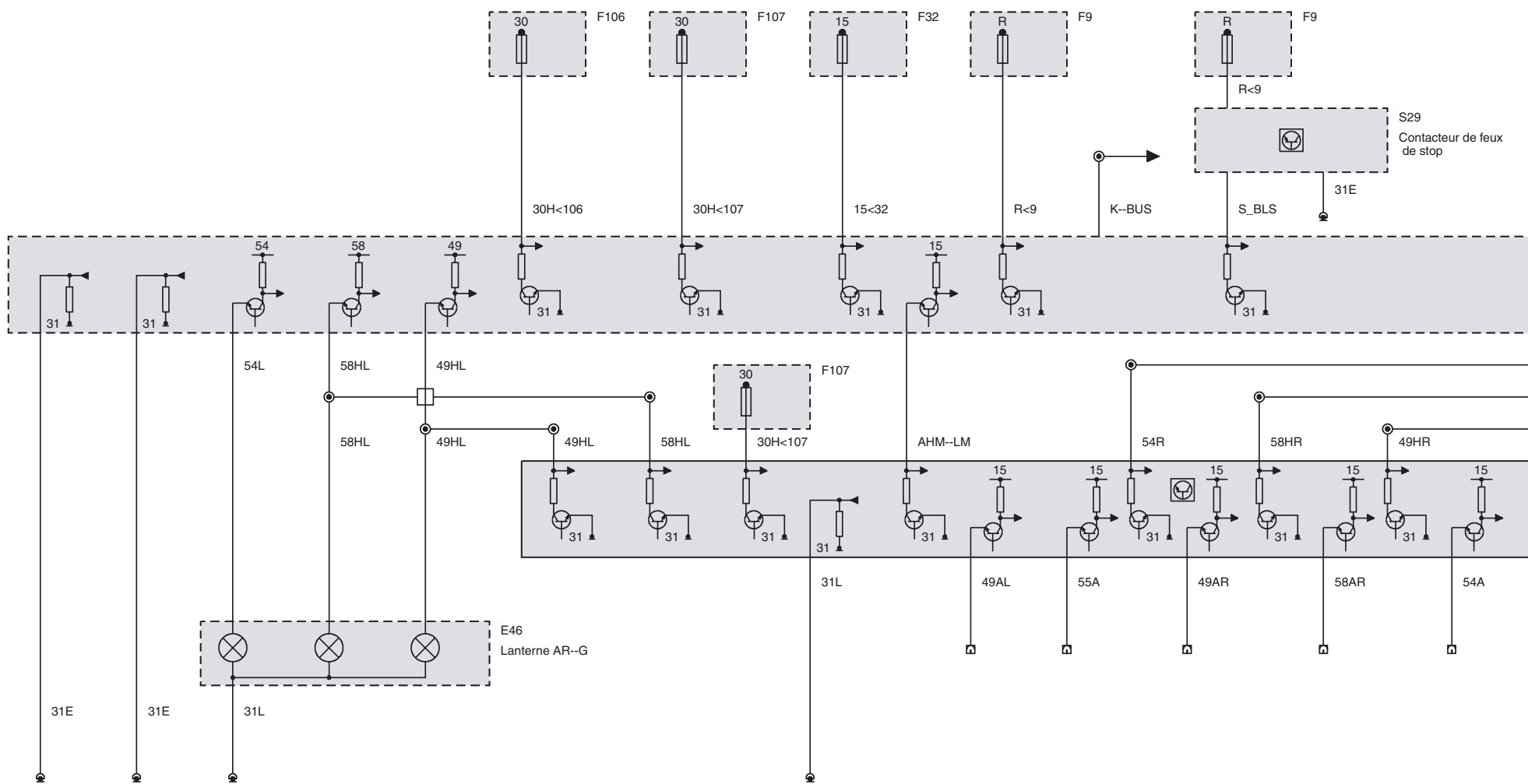



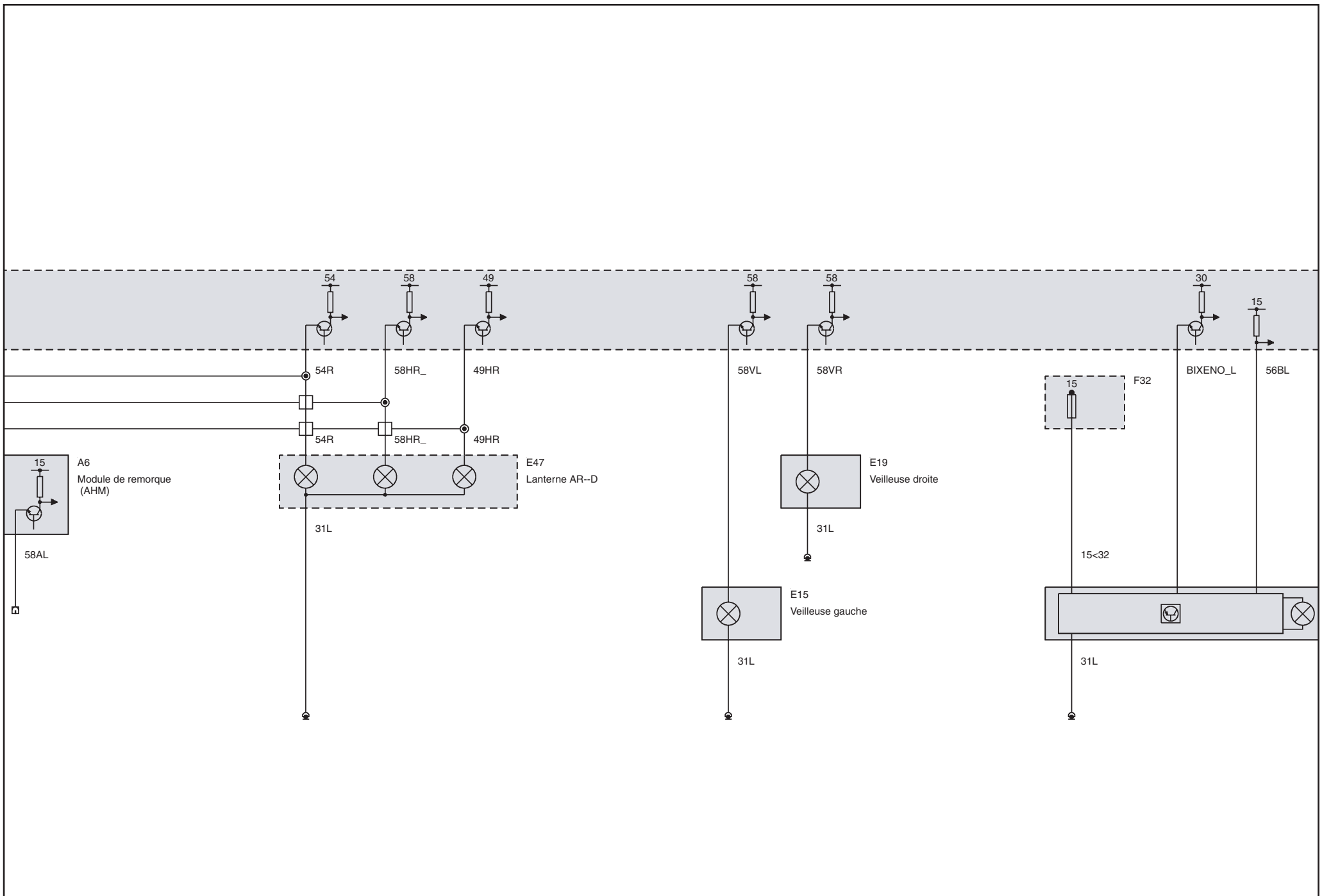

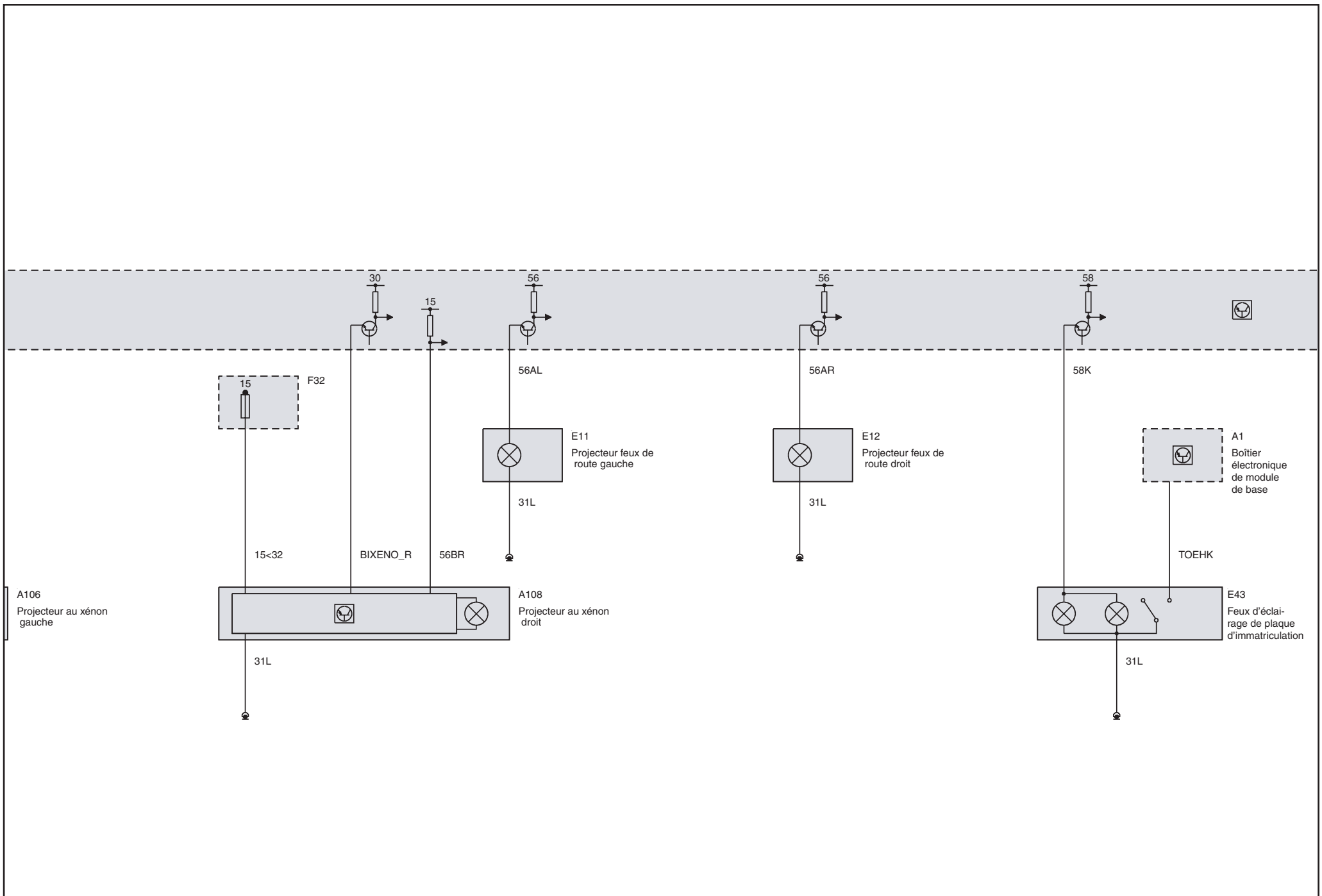

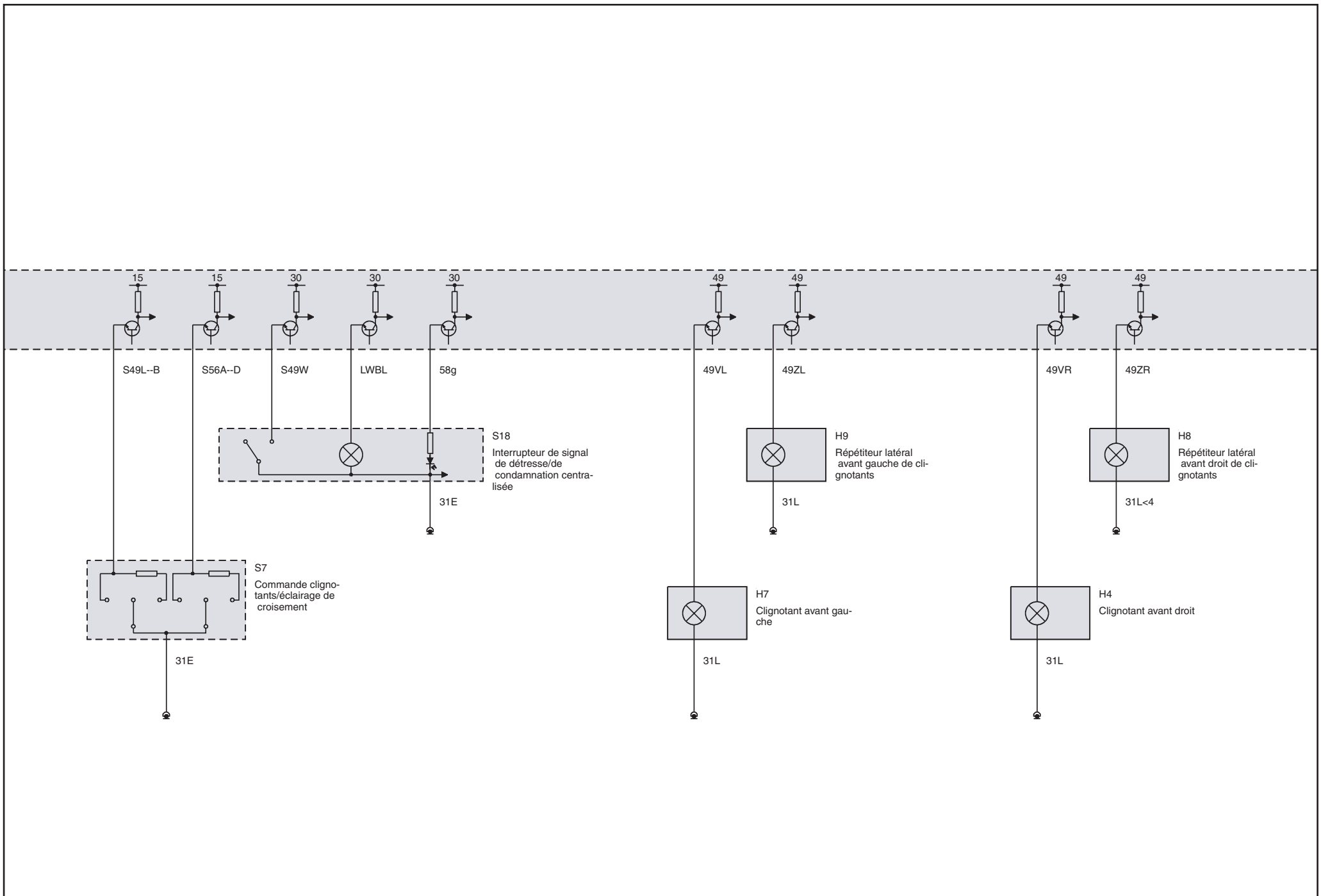

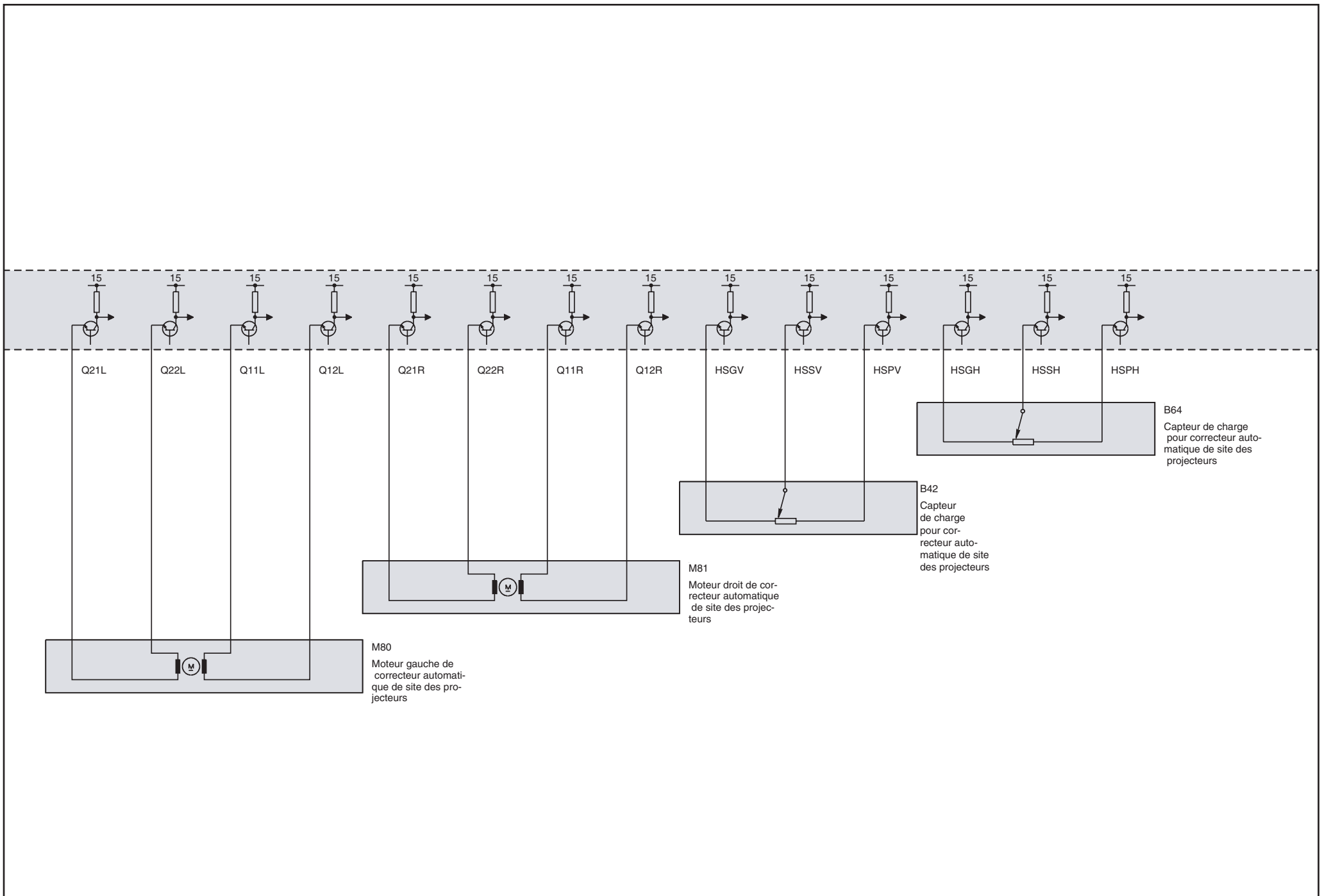

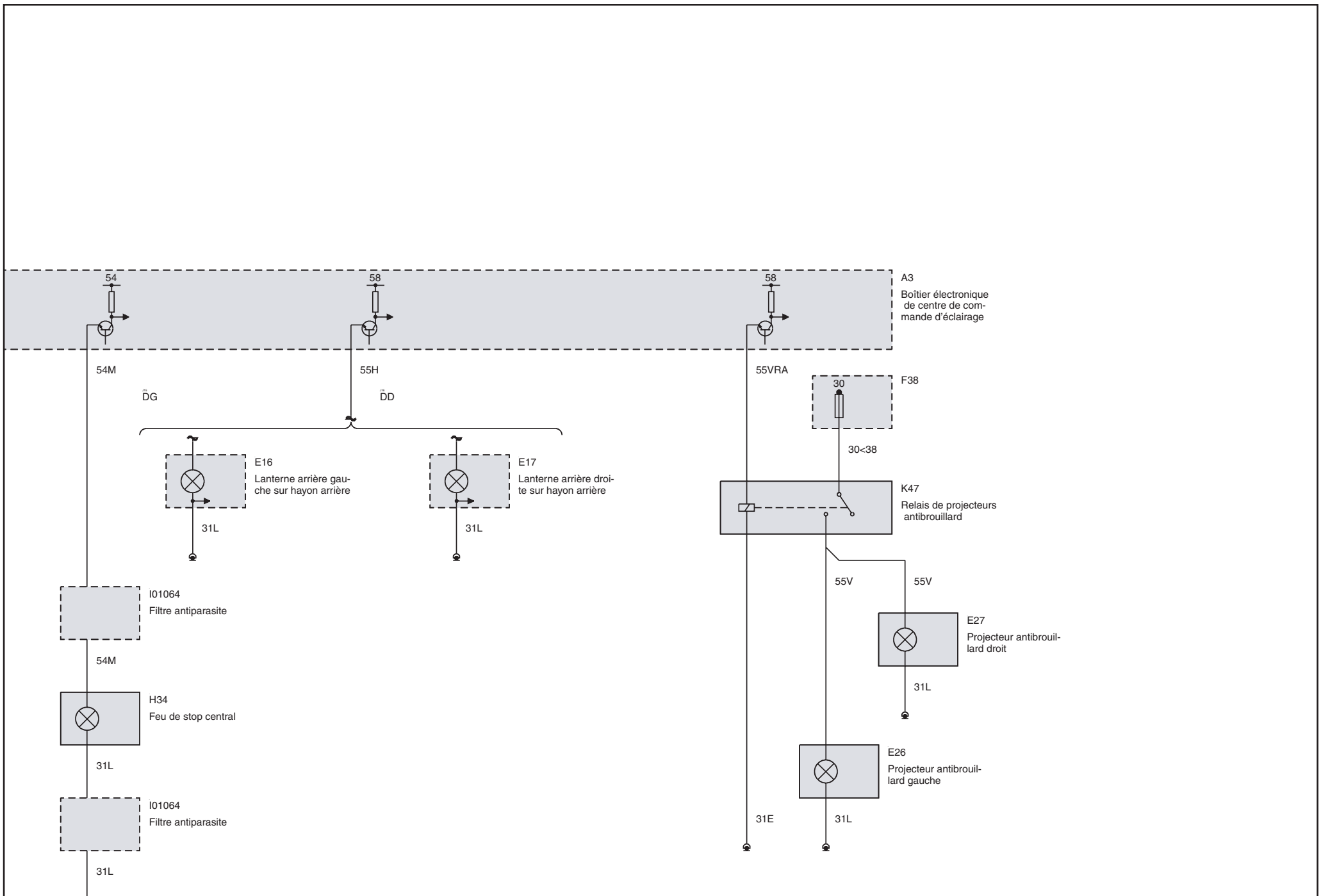

Eclairage (Compact sans Phare au xénon)

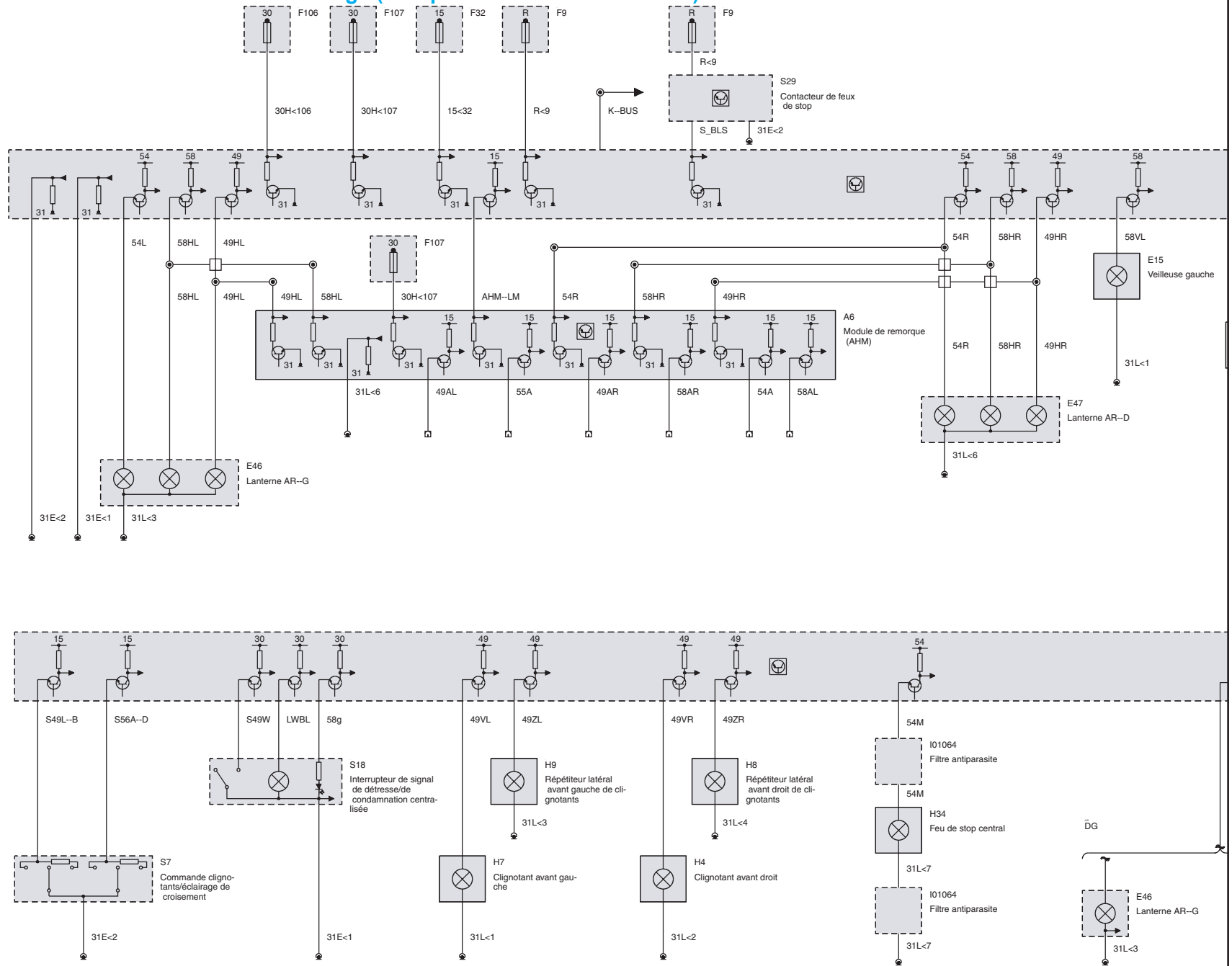

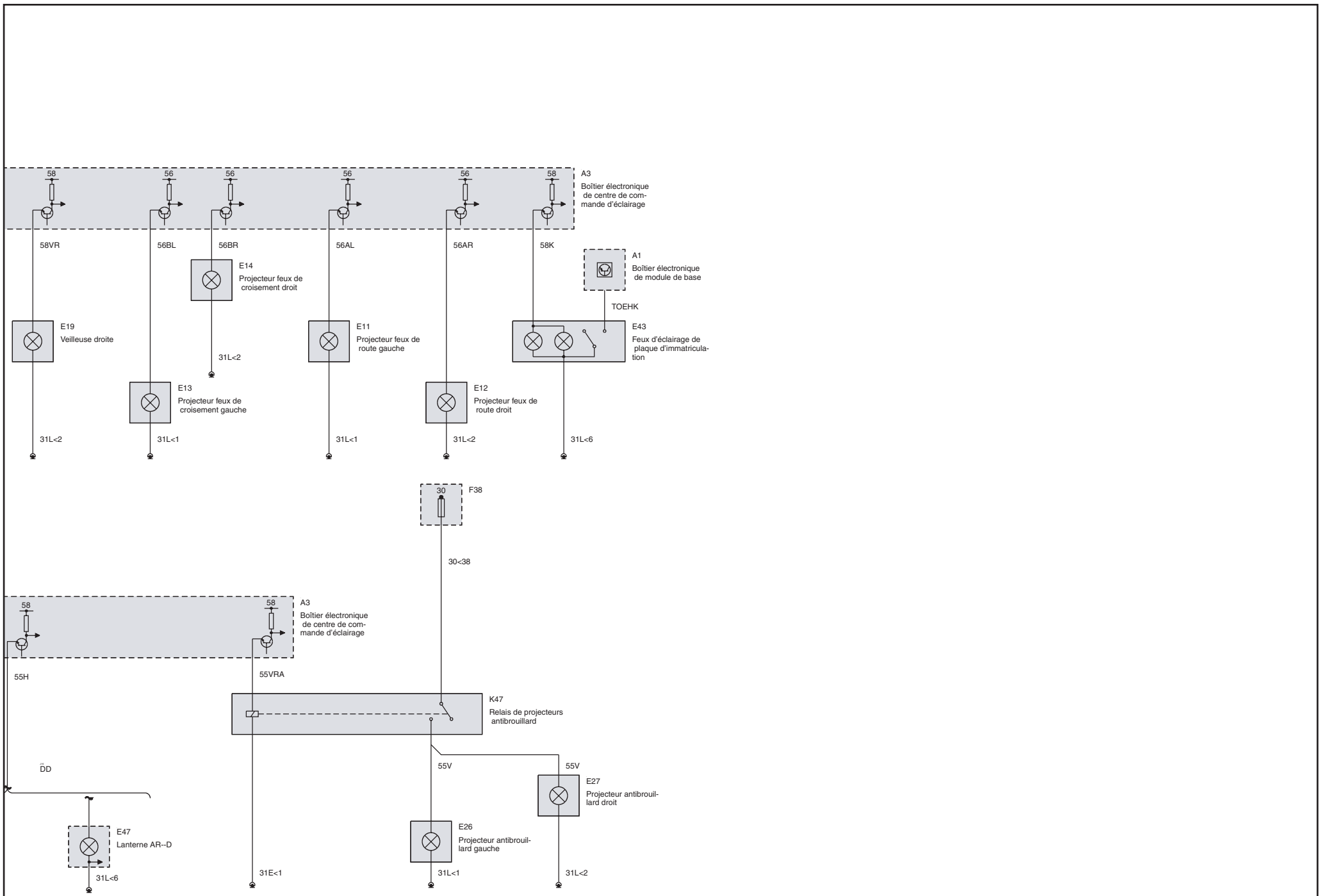

Eclairage (Compact avec Phare au xénon à partir de 2001\_09 jusque 2003\_03)

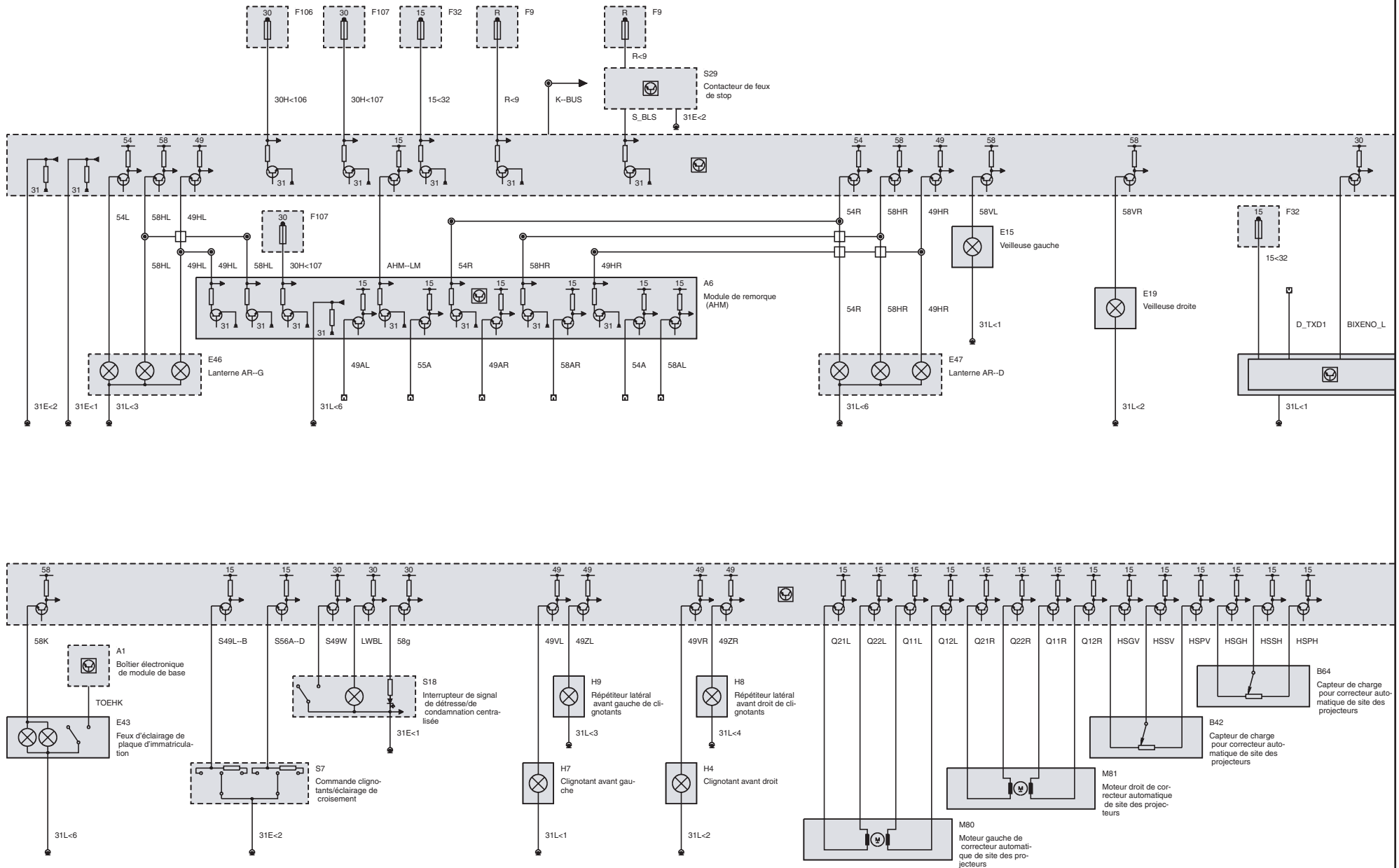



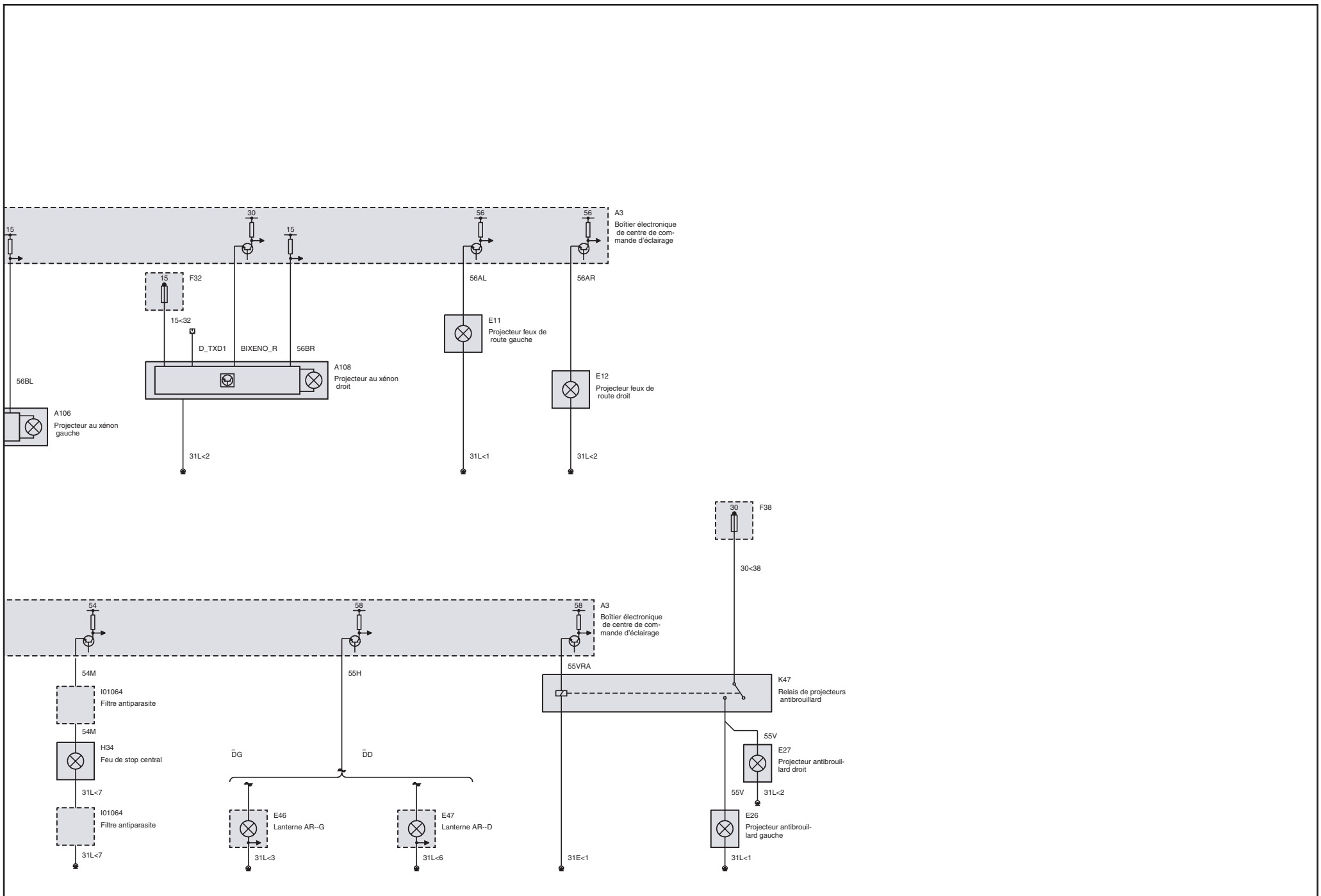

Eclairage (Compact avec Eclairage au xénon à partir de 2003\_03)

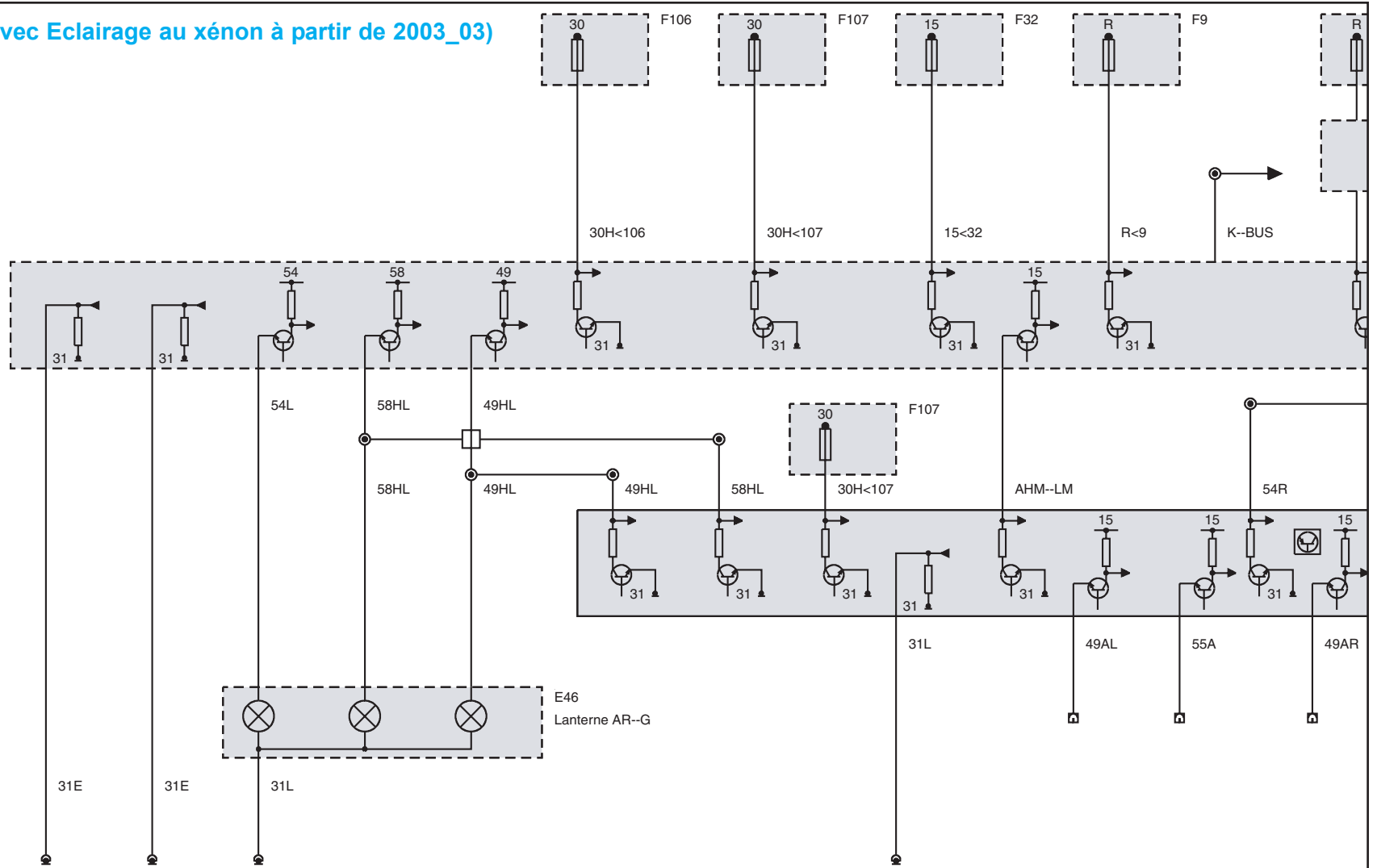

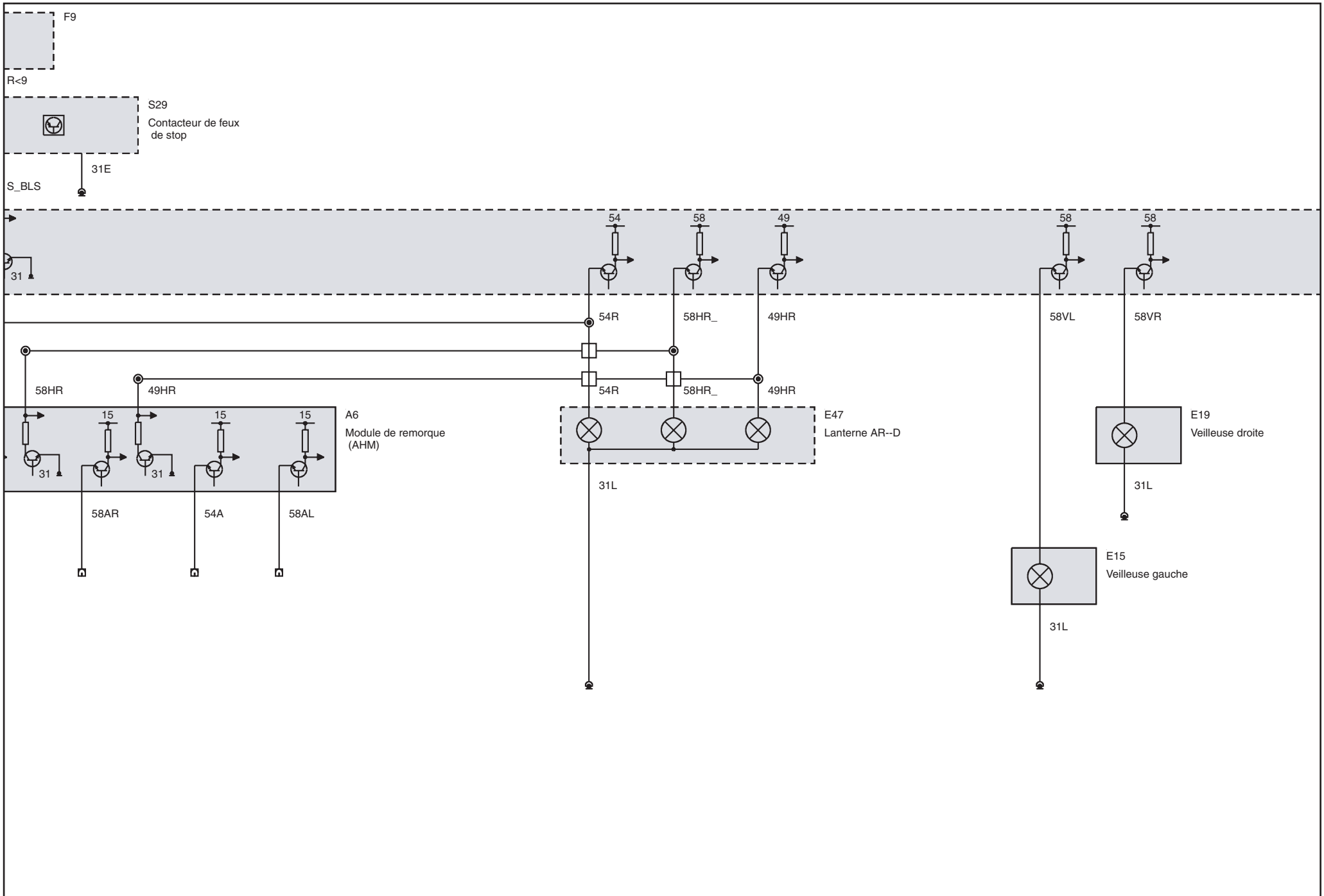

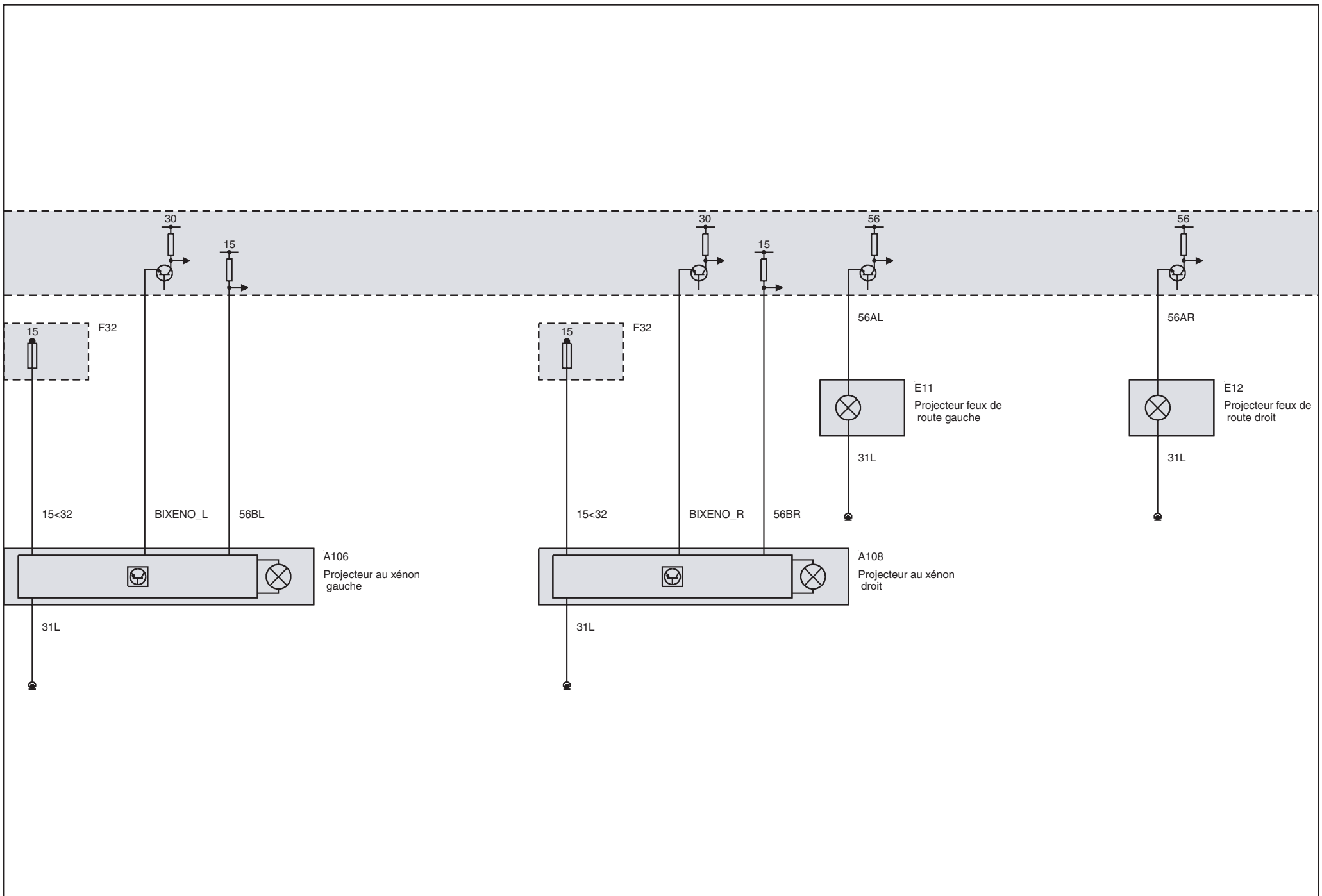

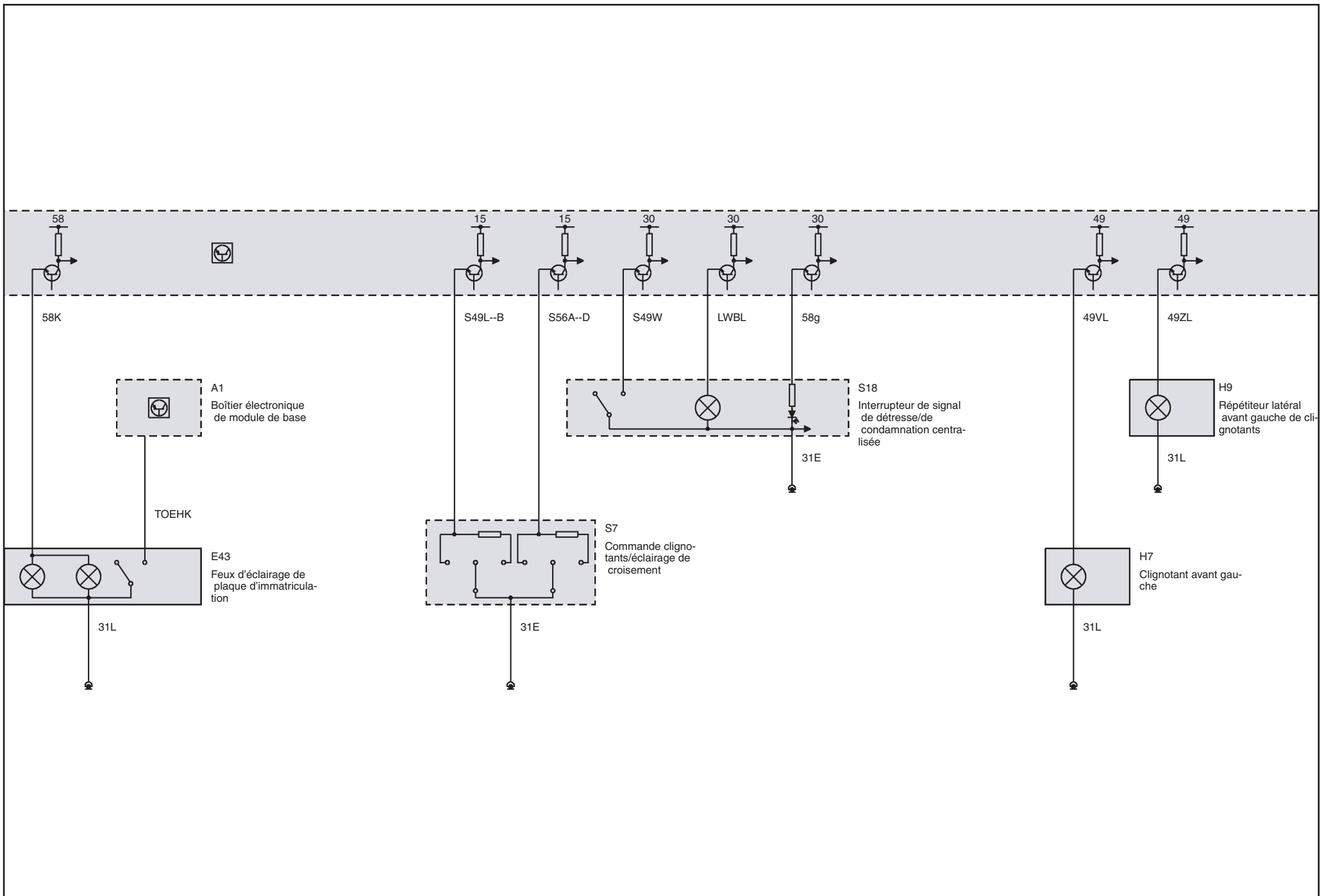

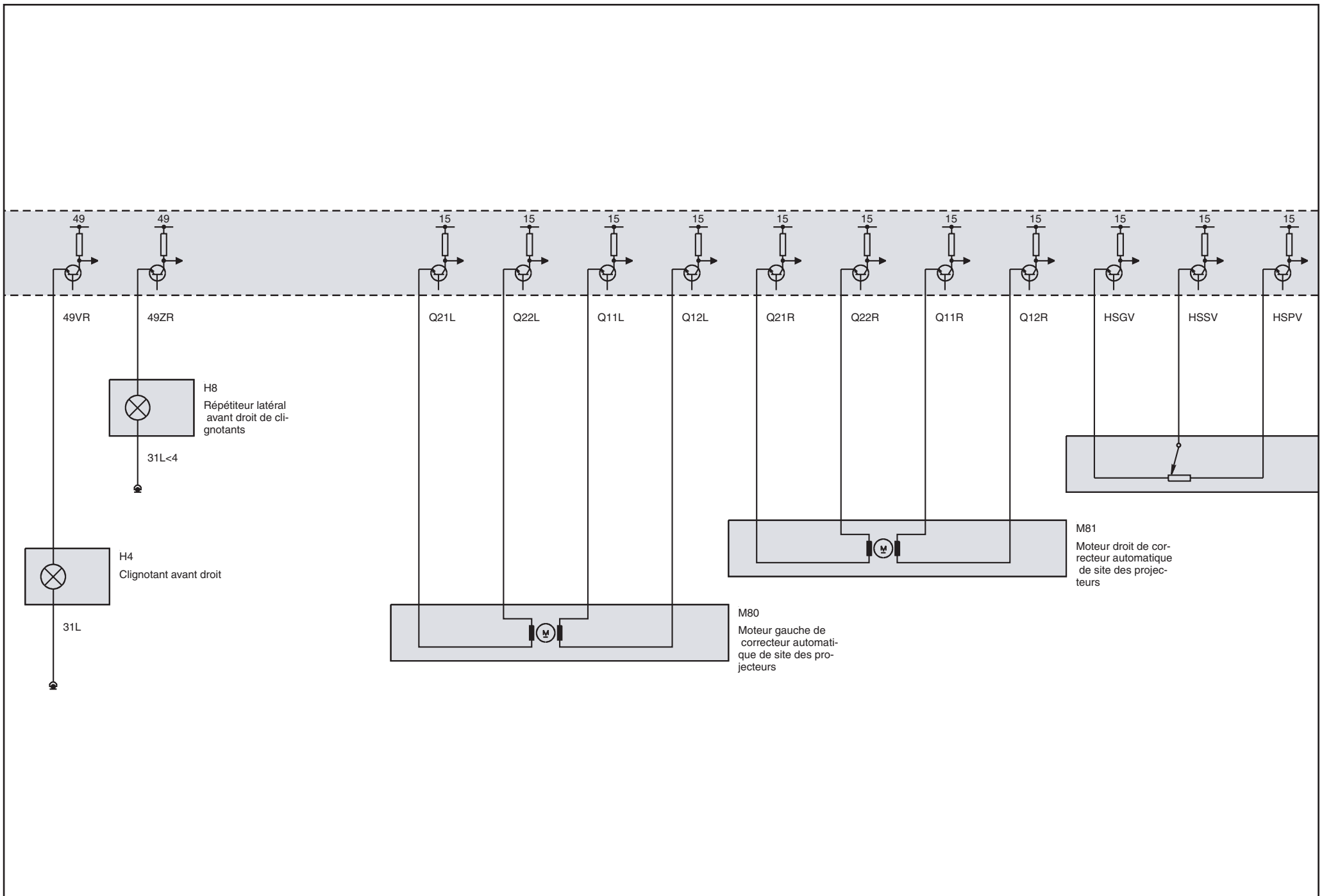

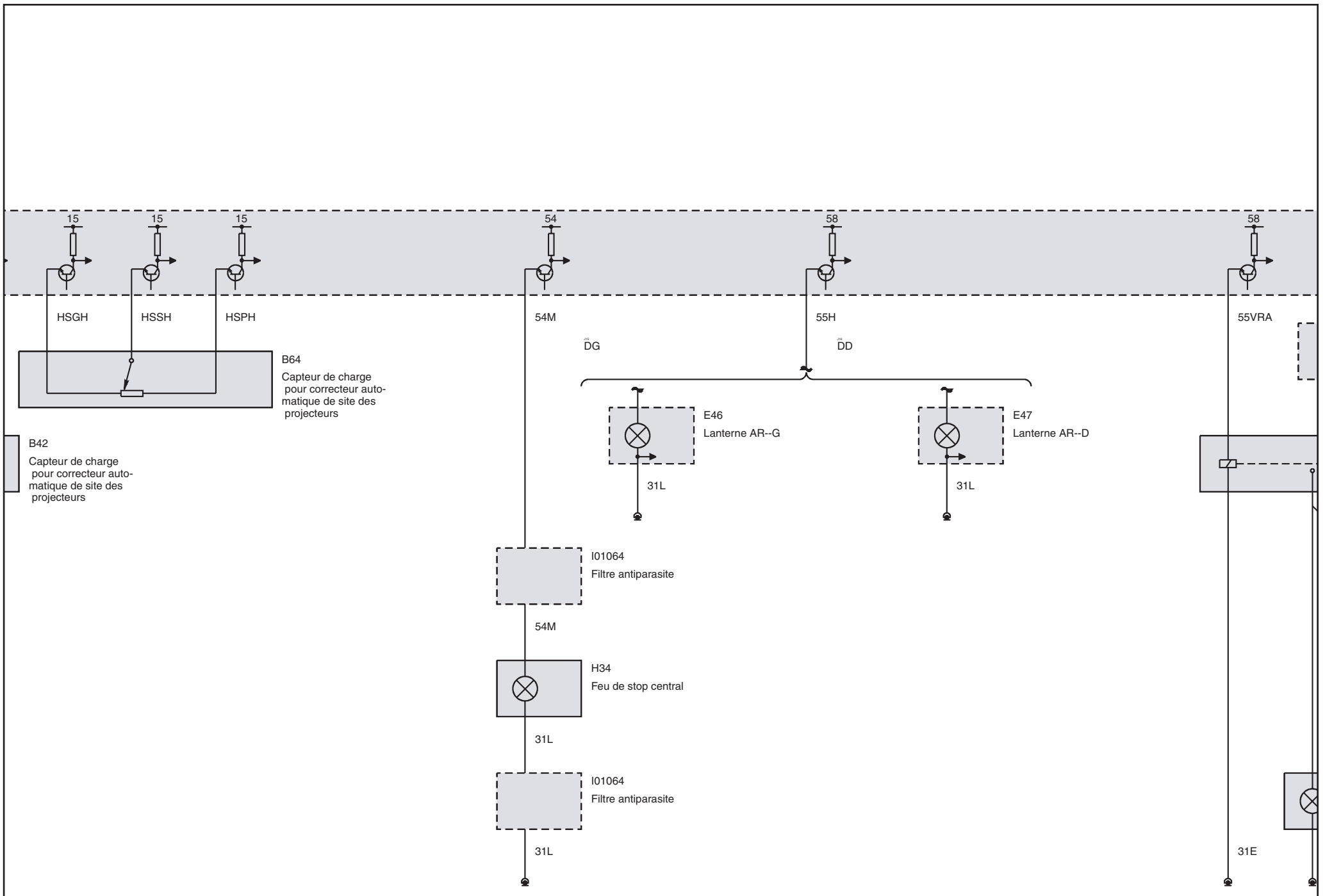

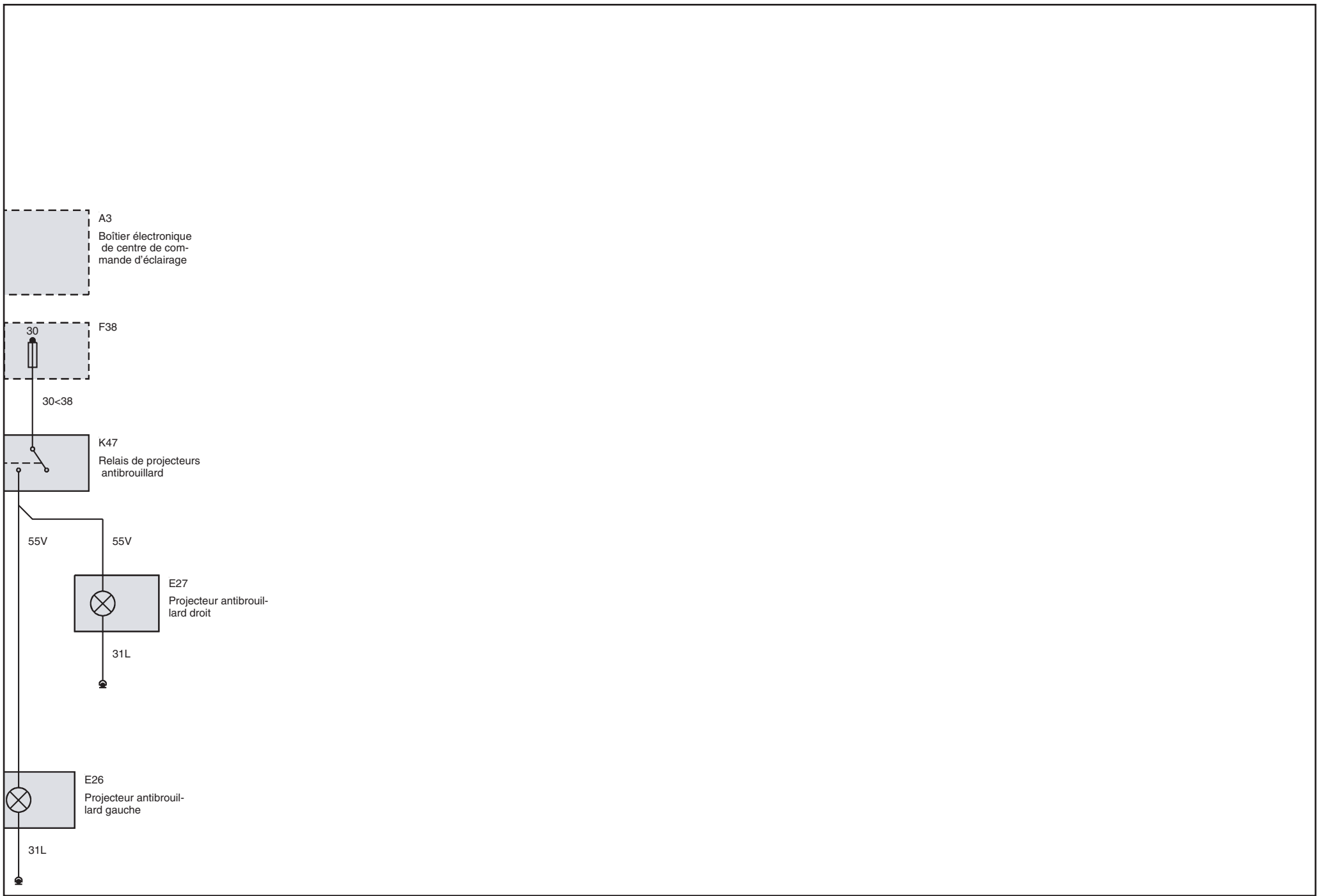



Eclairage (Coupé ou Cabriolet sans Eclairage au xénon à partir de 2003\_03)

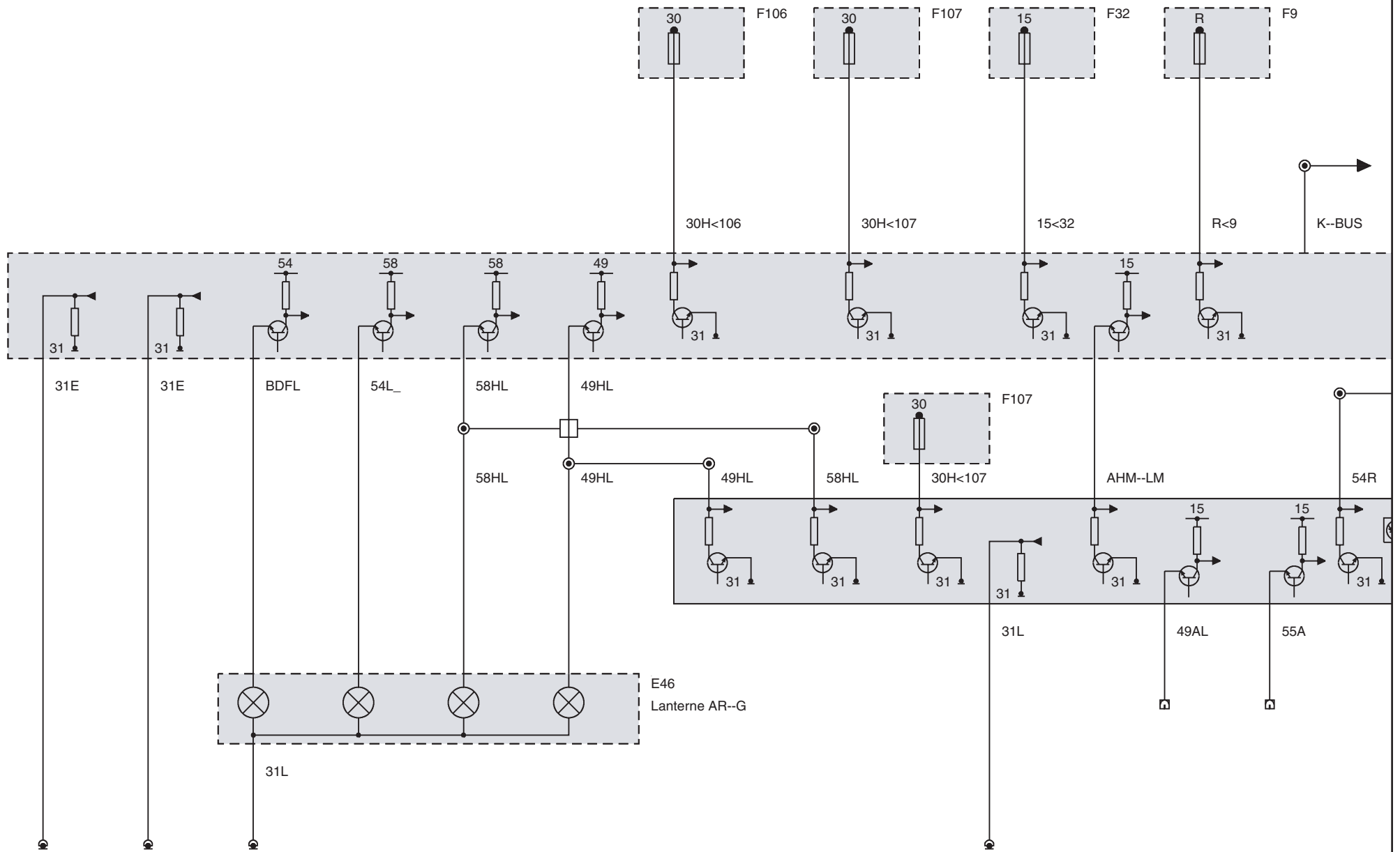

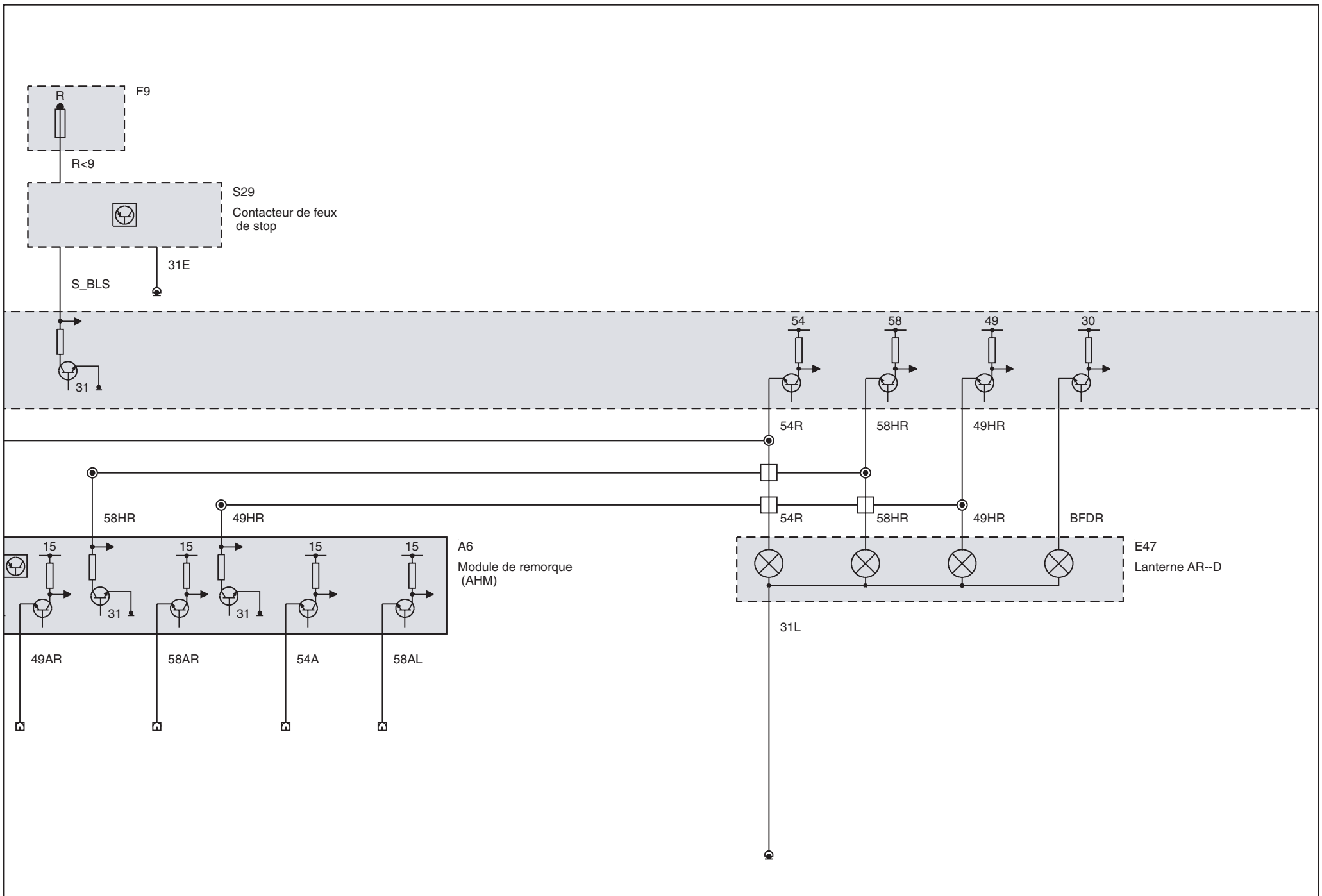

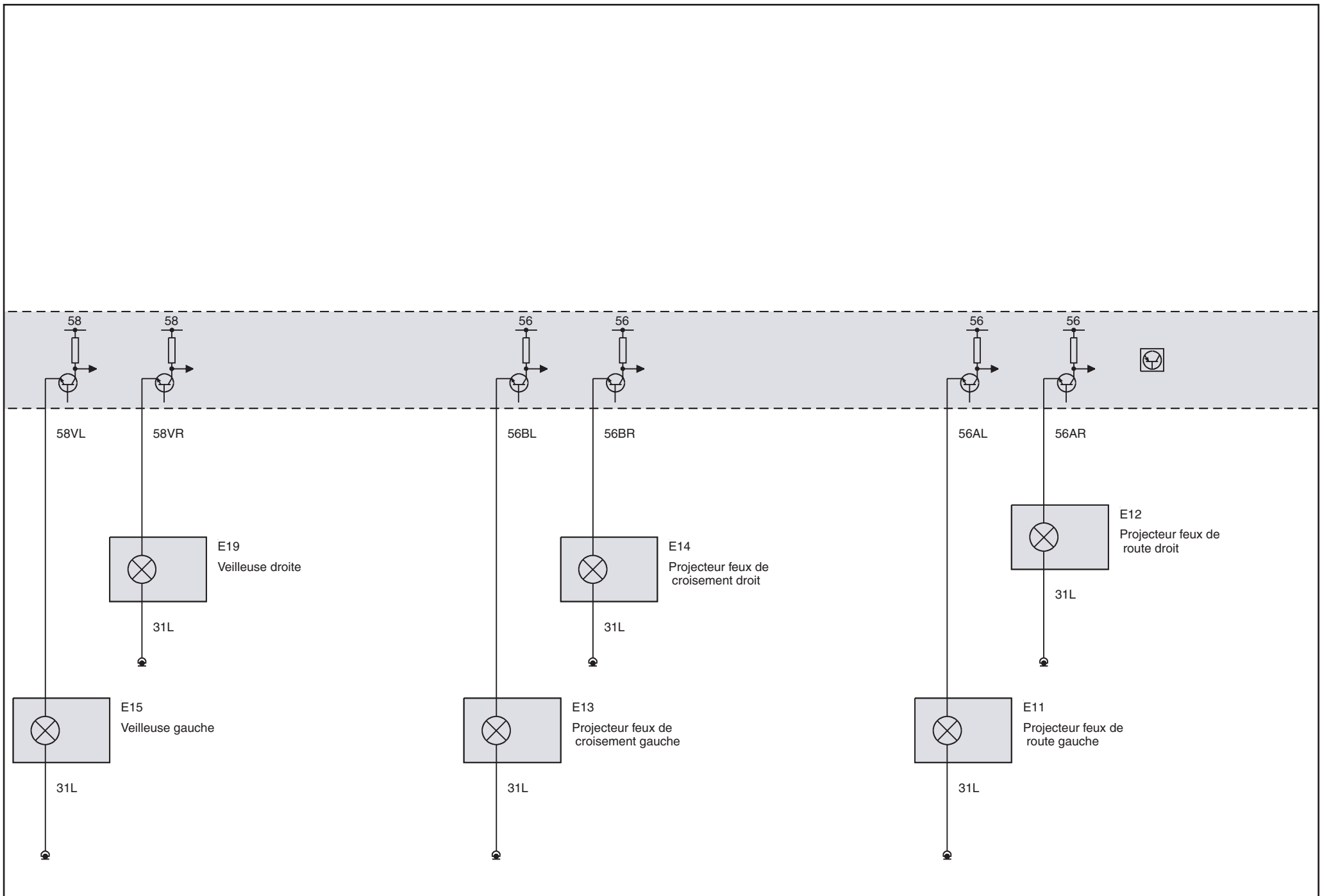

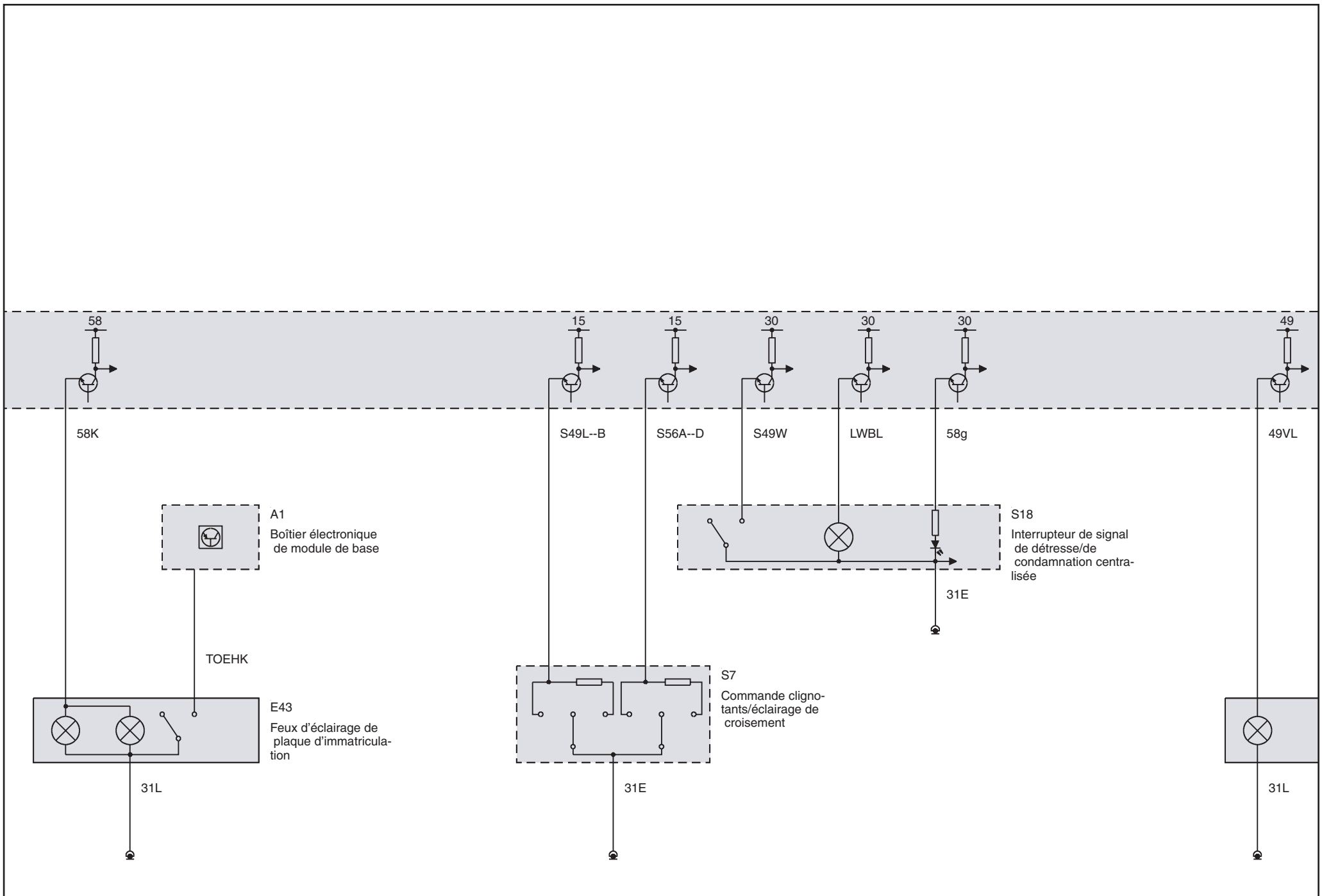

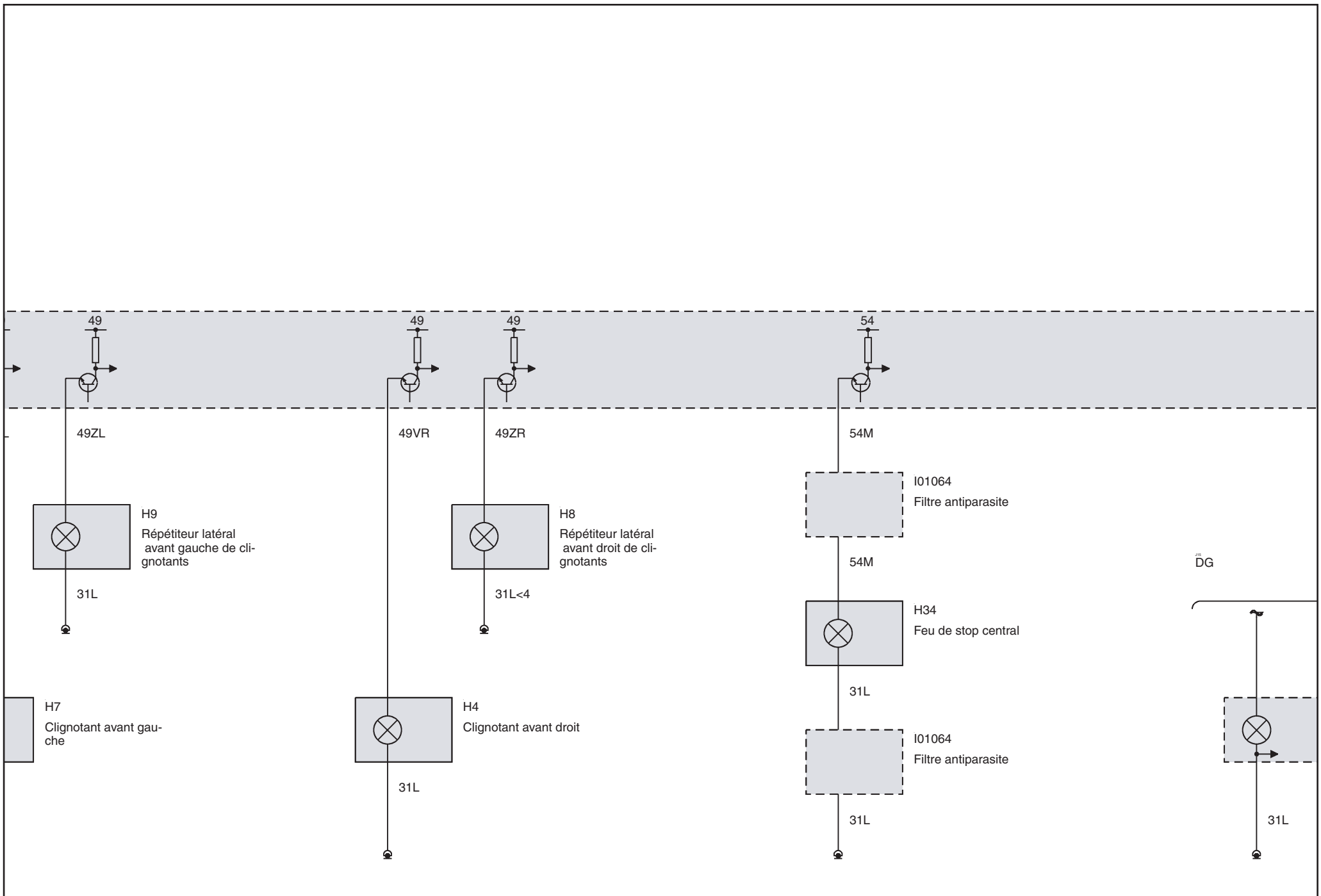

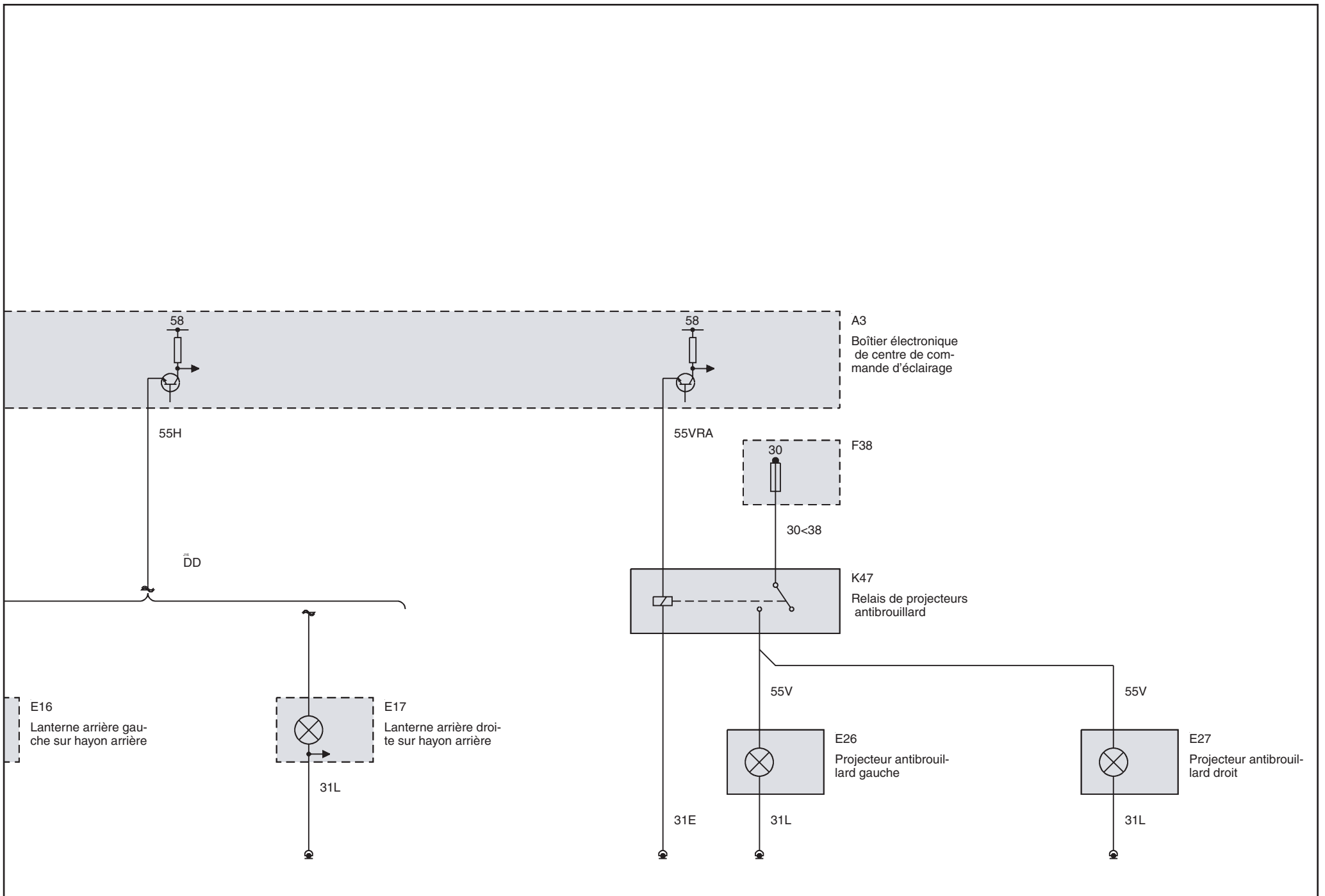

Eclairage (Coupé ou Cabriolet avec Eclairage au xénon à partir de 2003\_03)

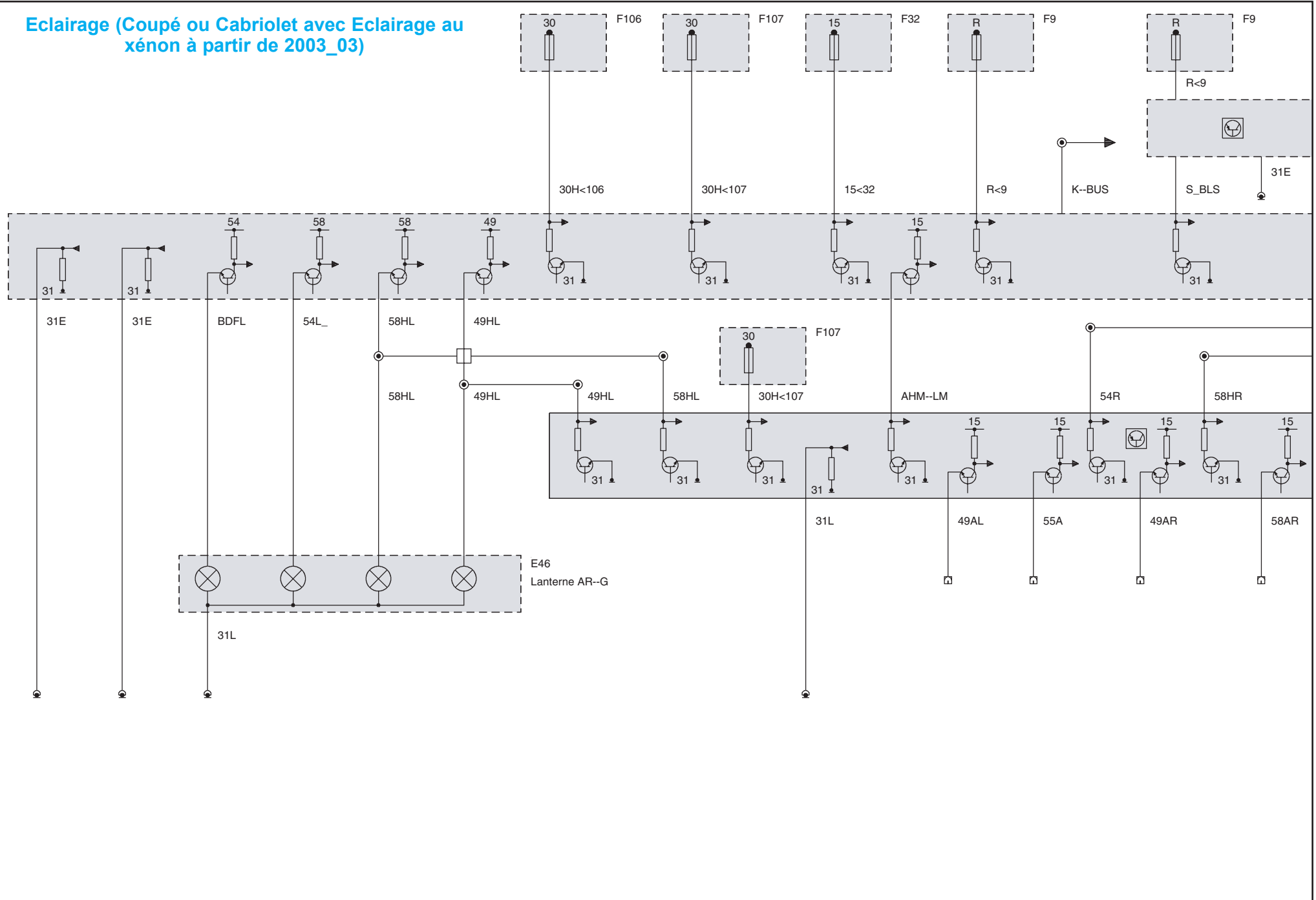

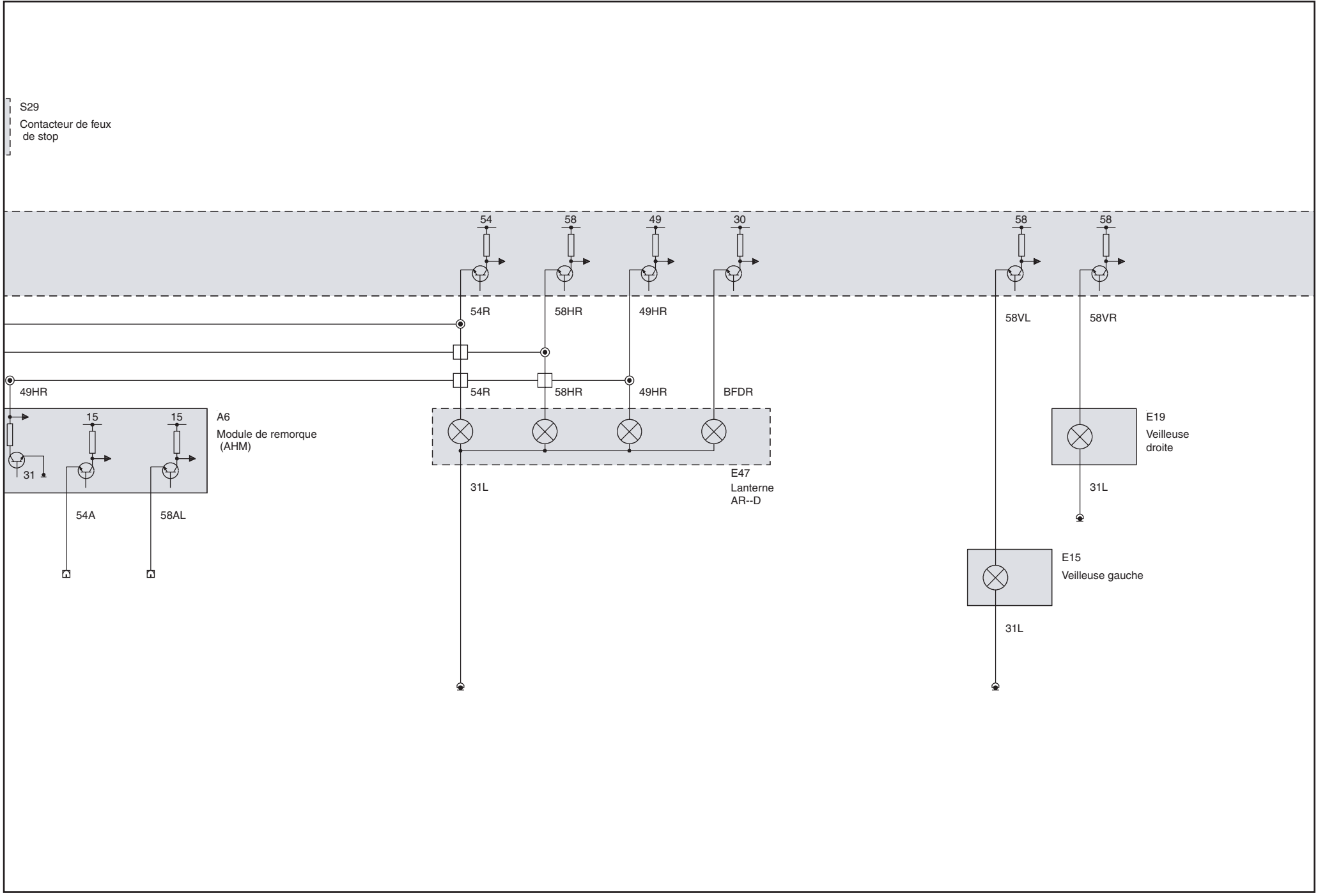

S29  
Contacteur de feux  
de stop

A6  
Module de remorque  
(AHM)

E47  
Lanterne  
AR--D

E19  
Veilleuse  
droite

E15  
Veilleuse  
gauche



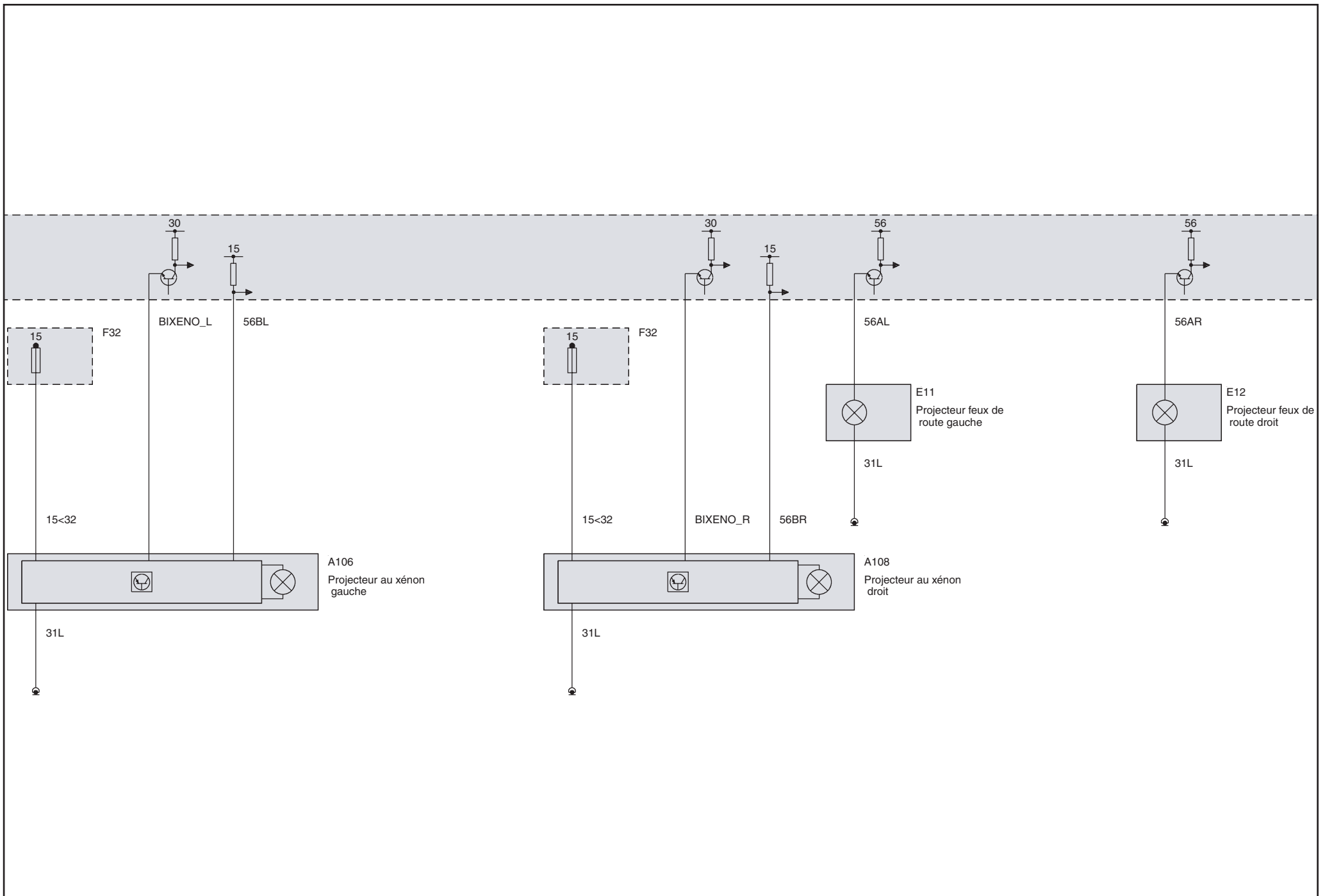

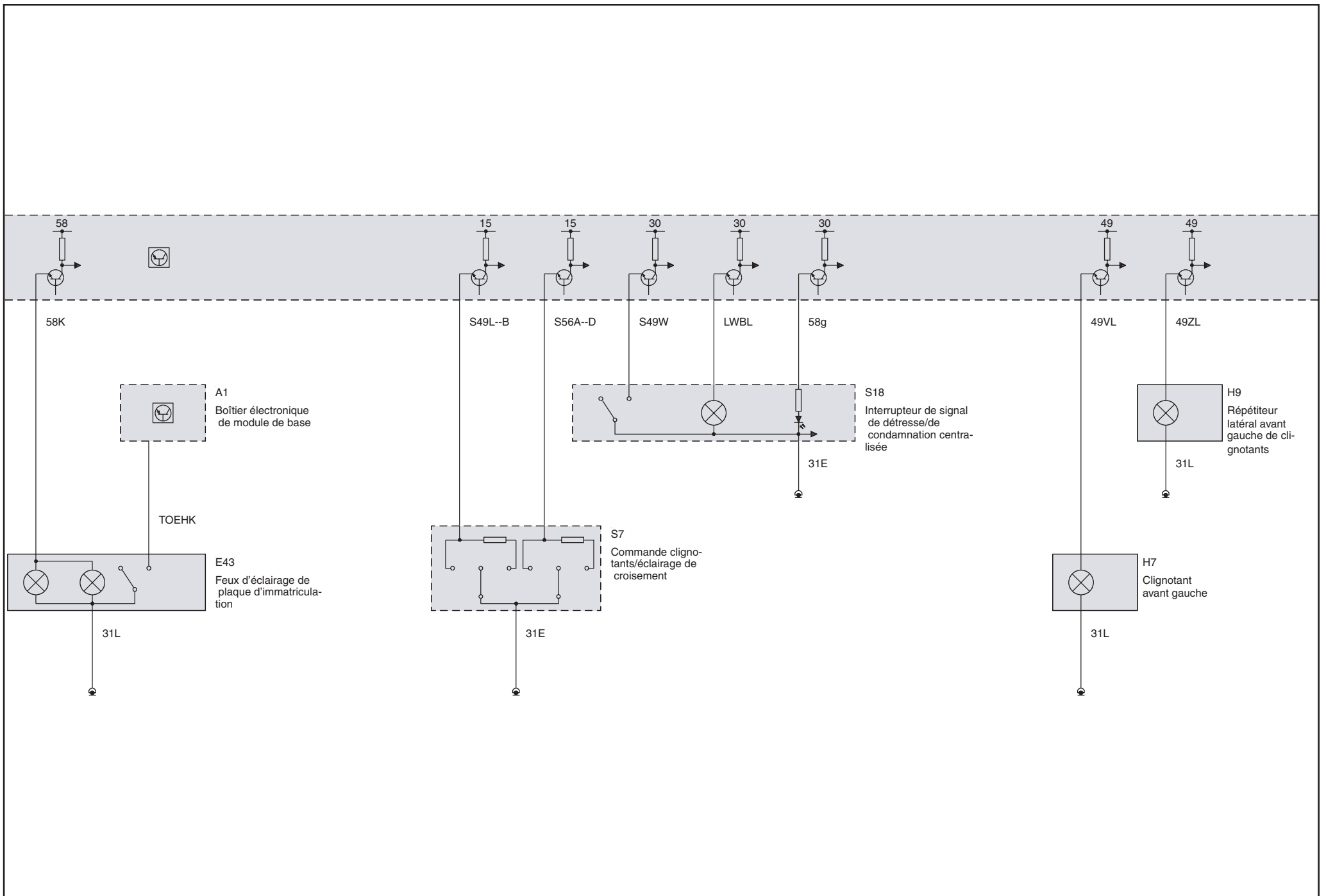

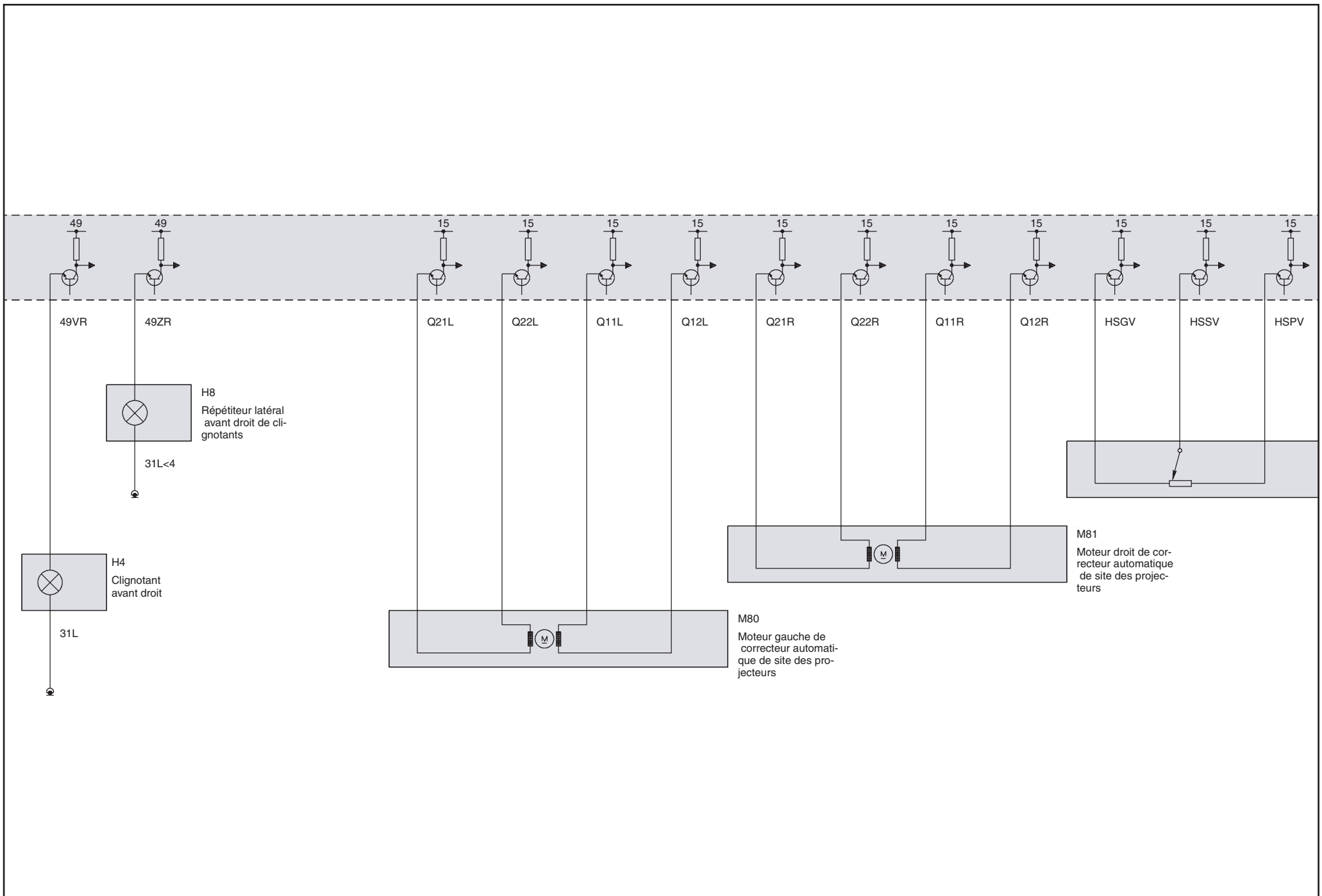

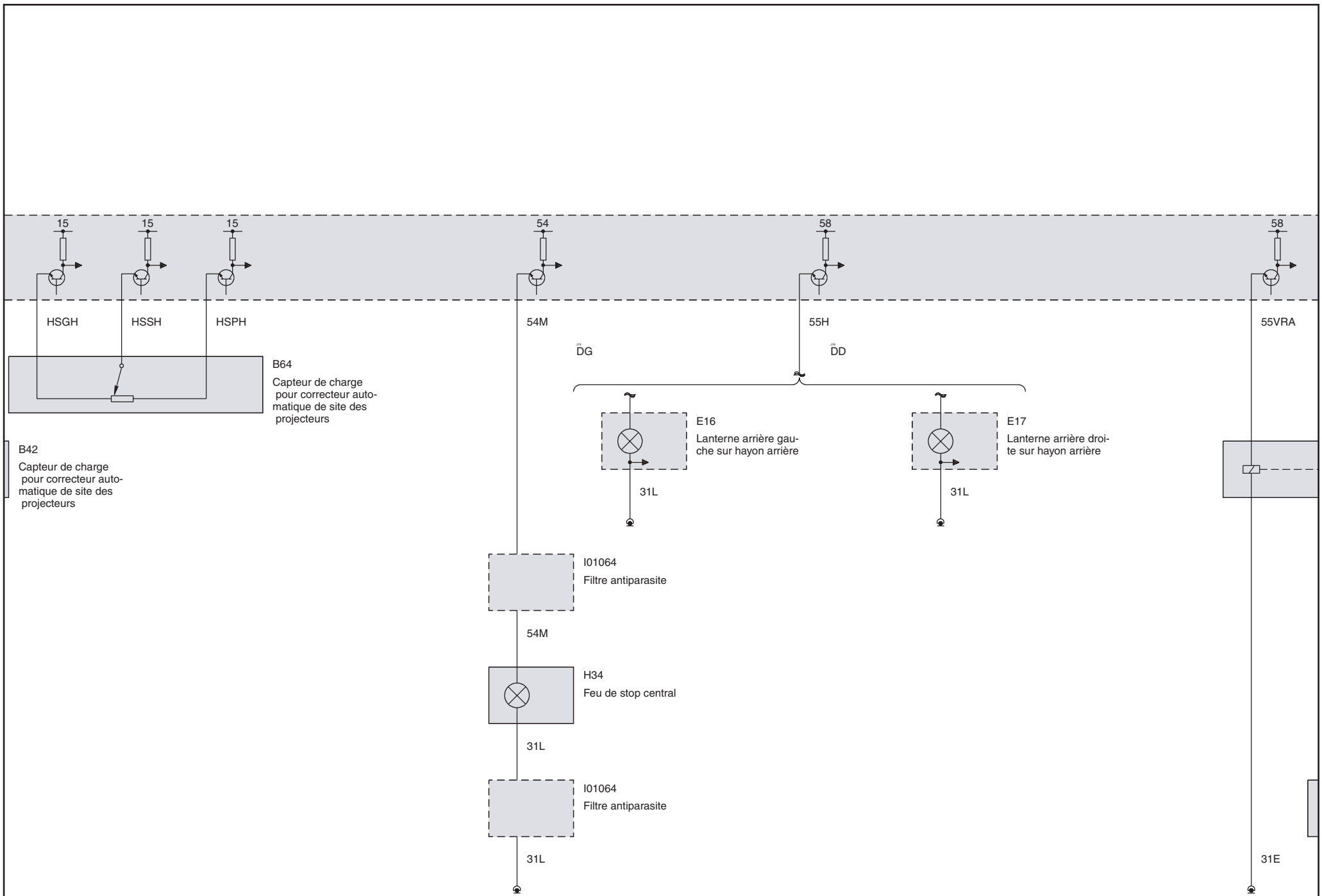

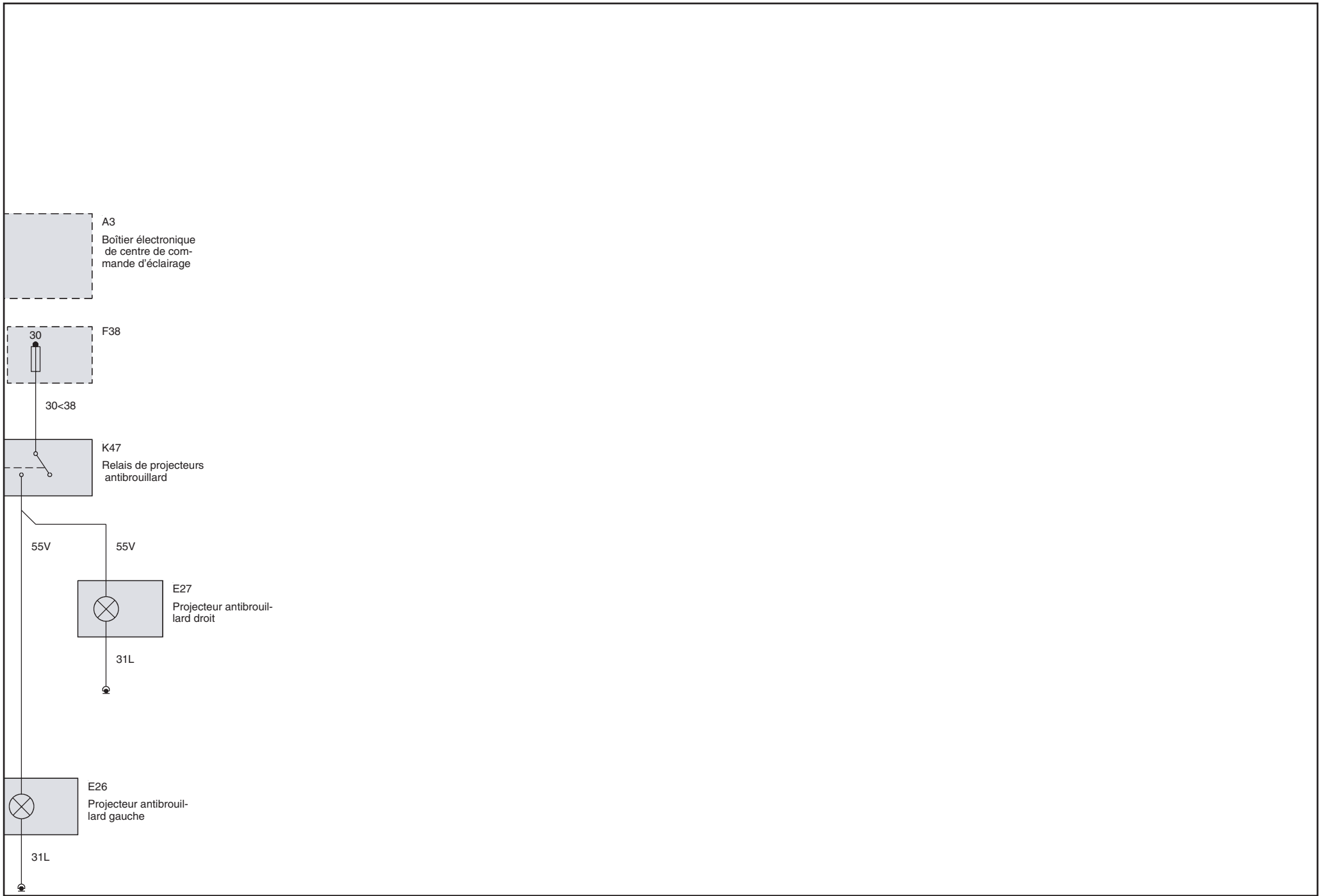

Alimentation

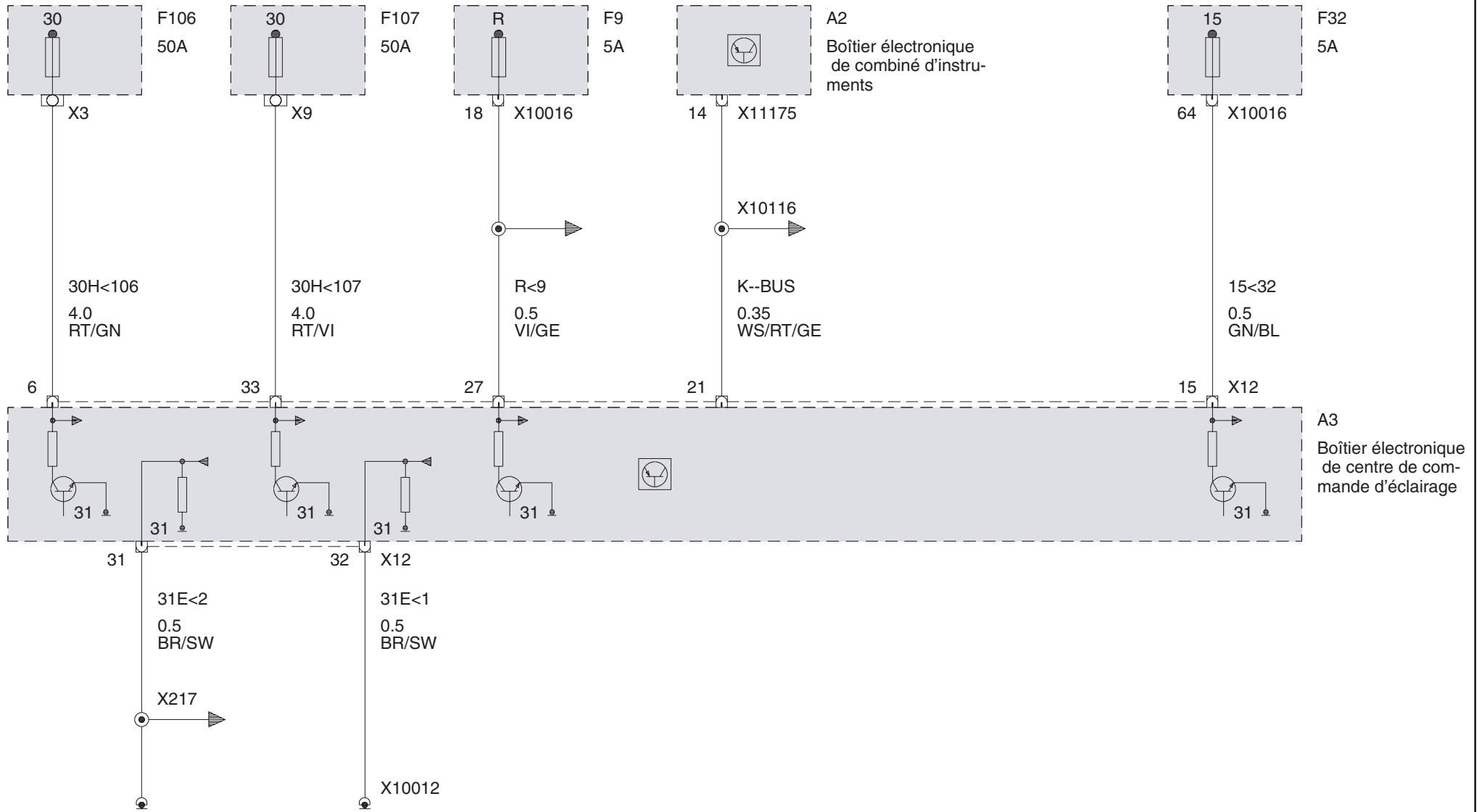

## Manette d'éclairage/signalisation

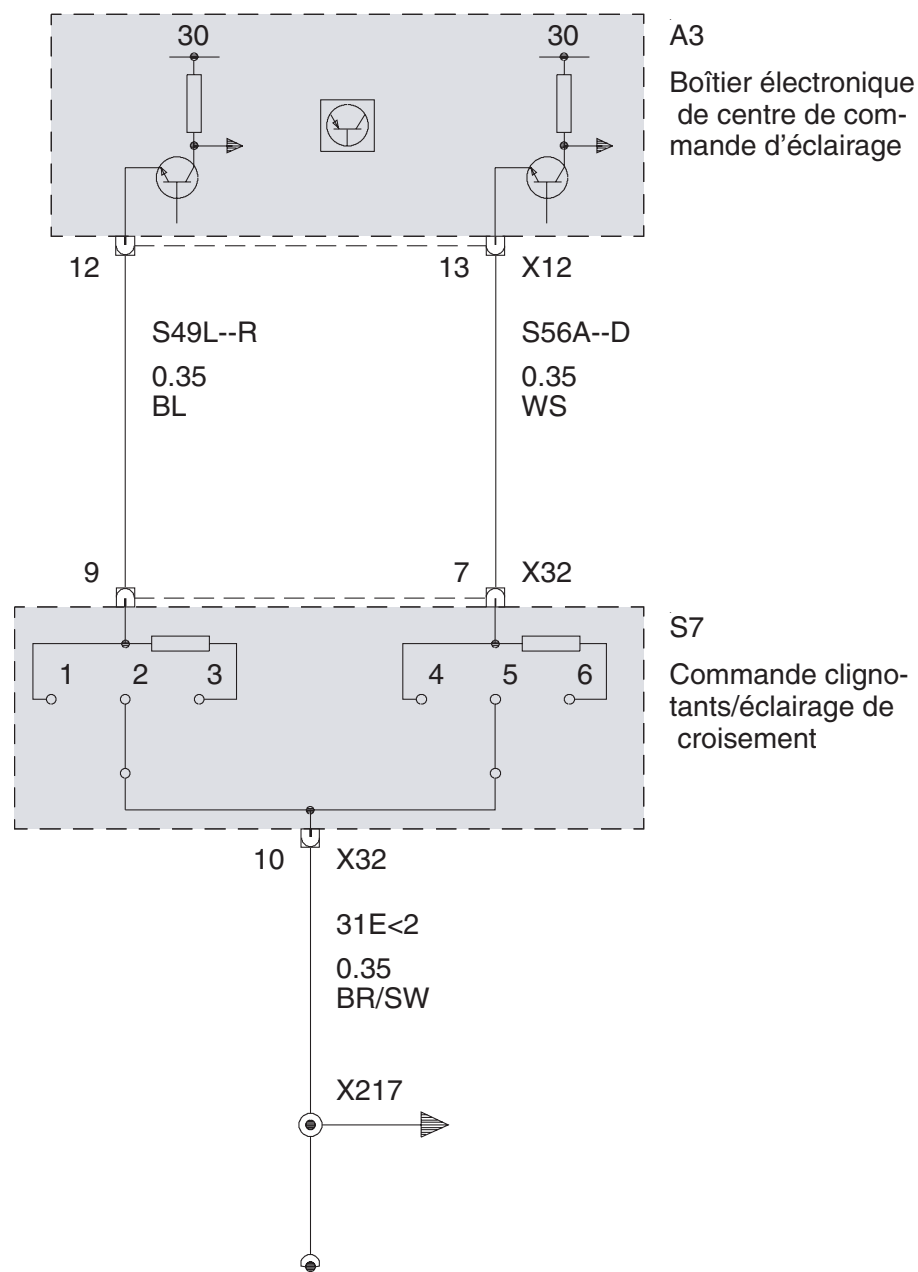

Feu de position  
Feu de position (Berline)

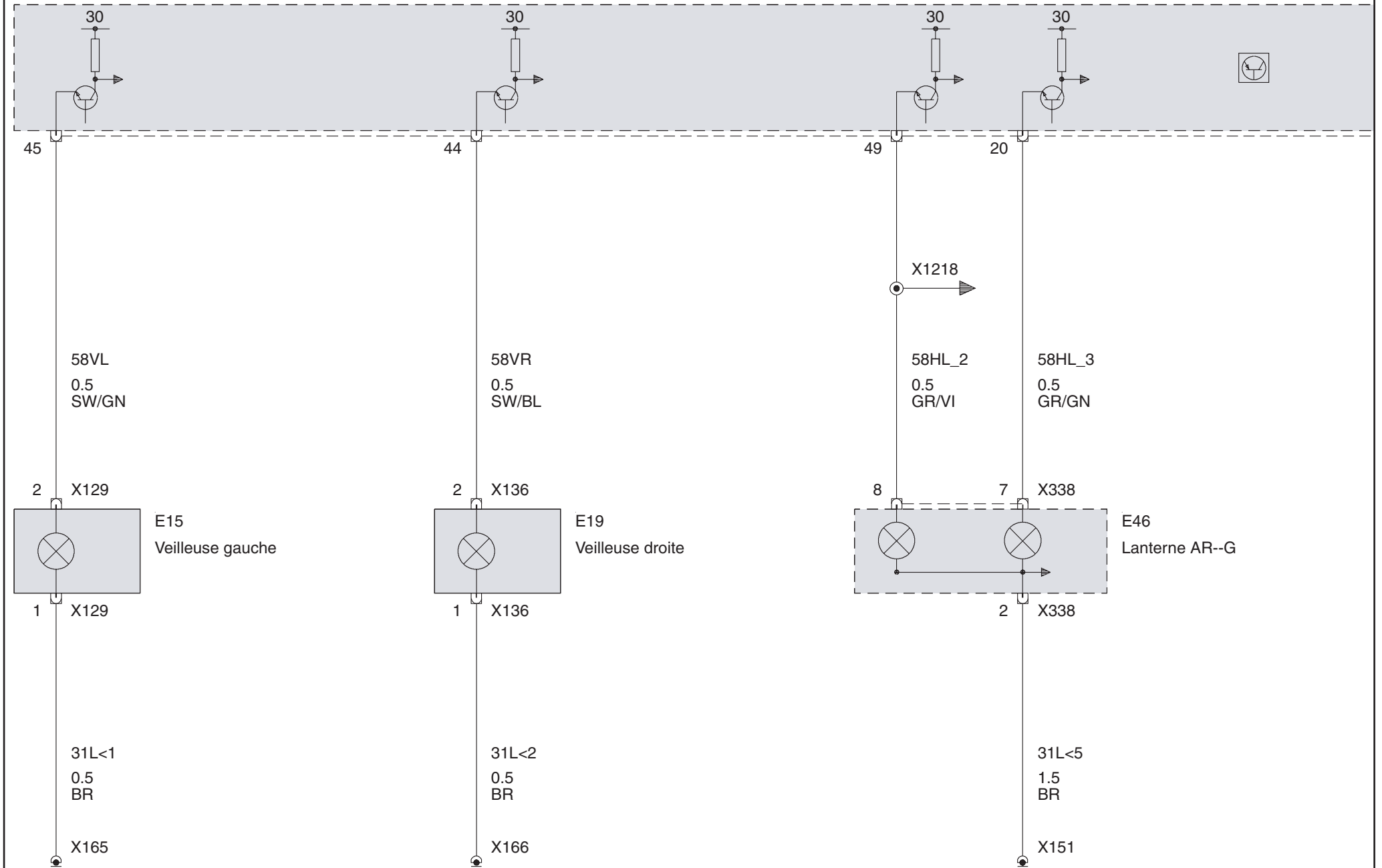



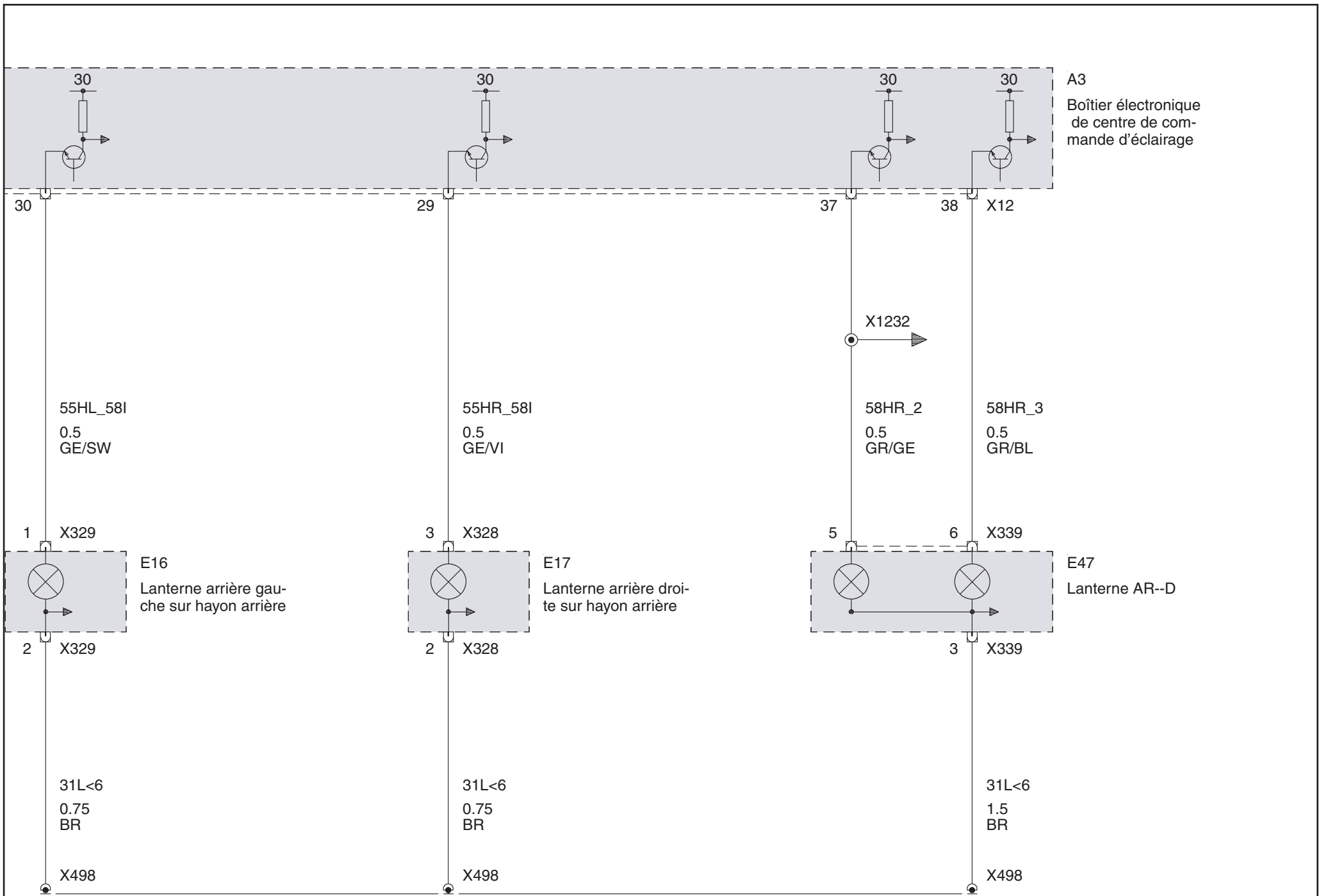

Feu de position (Coupé ou Cabriolet à partir de 2001\_09 jusque 2003\_03)

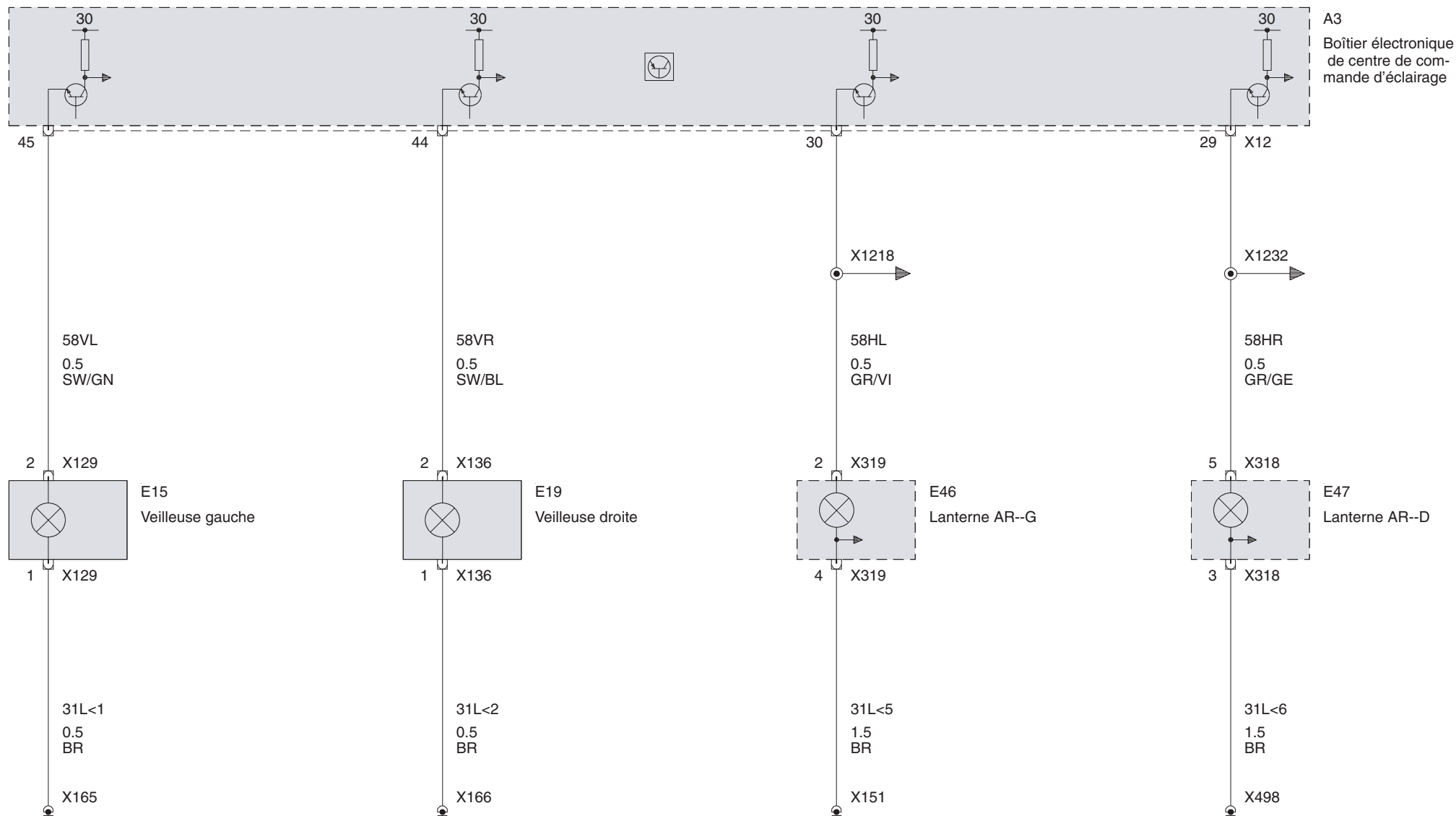

Feu de position (Coupé ou Cabriolet à partir de 2003\_03)

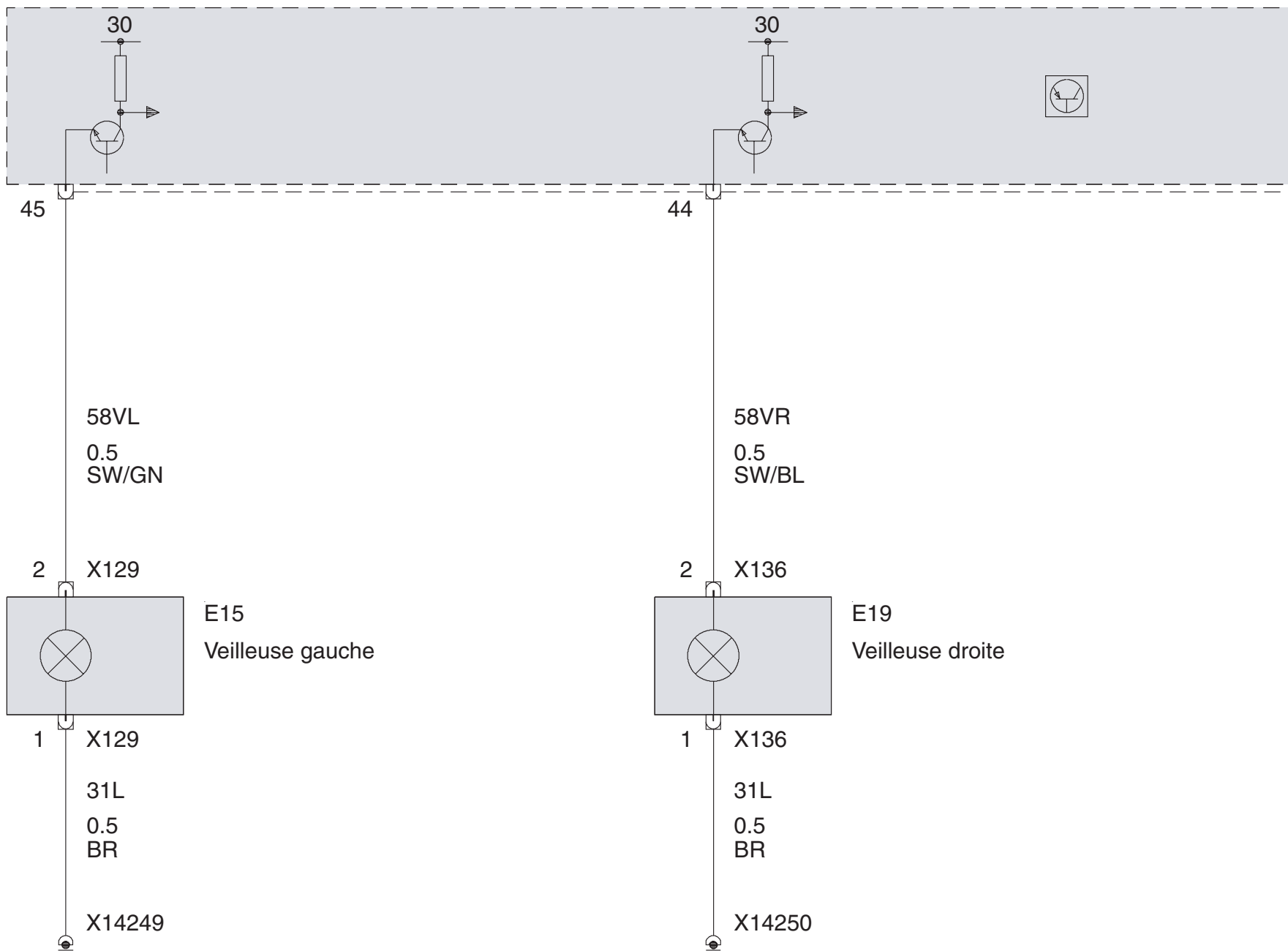

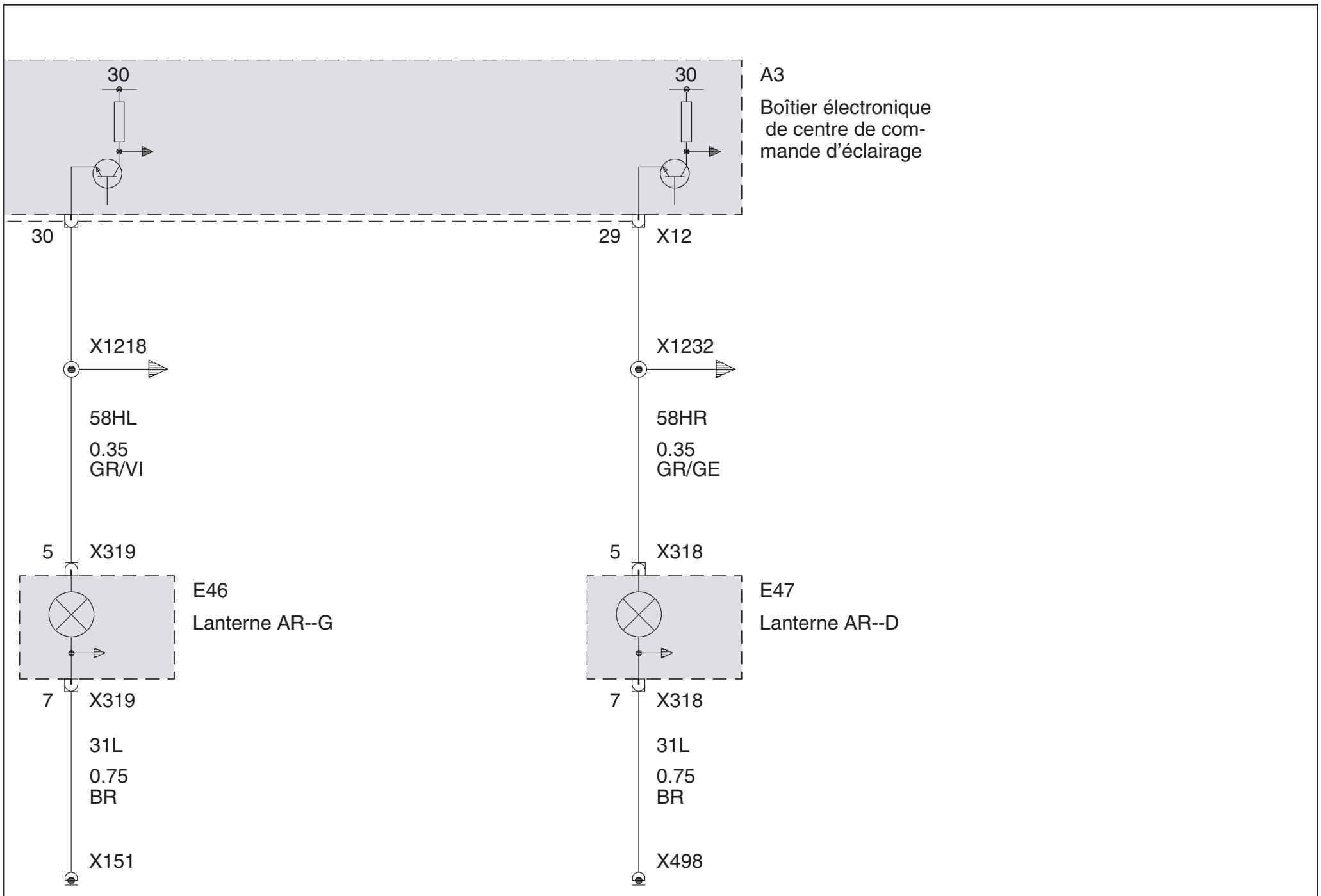

Feu de position (Touring)

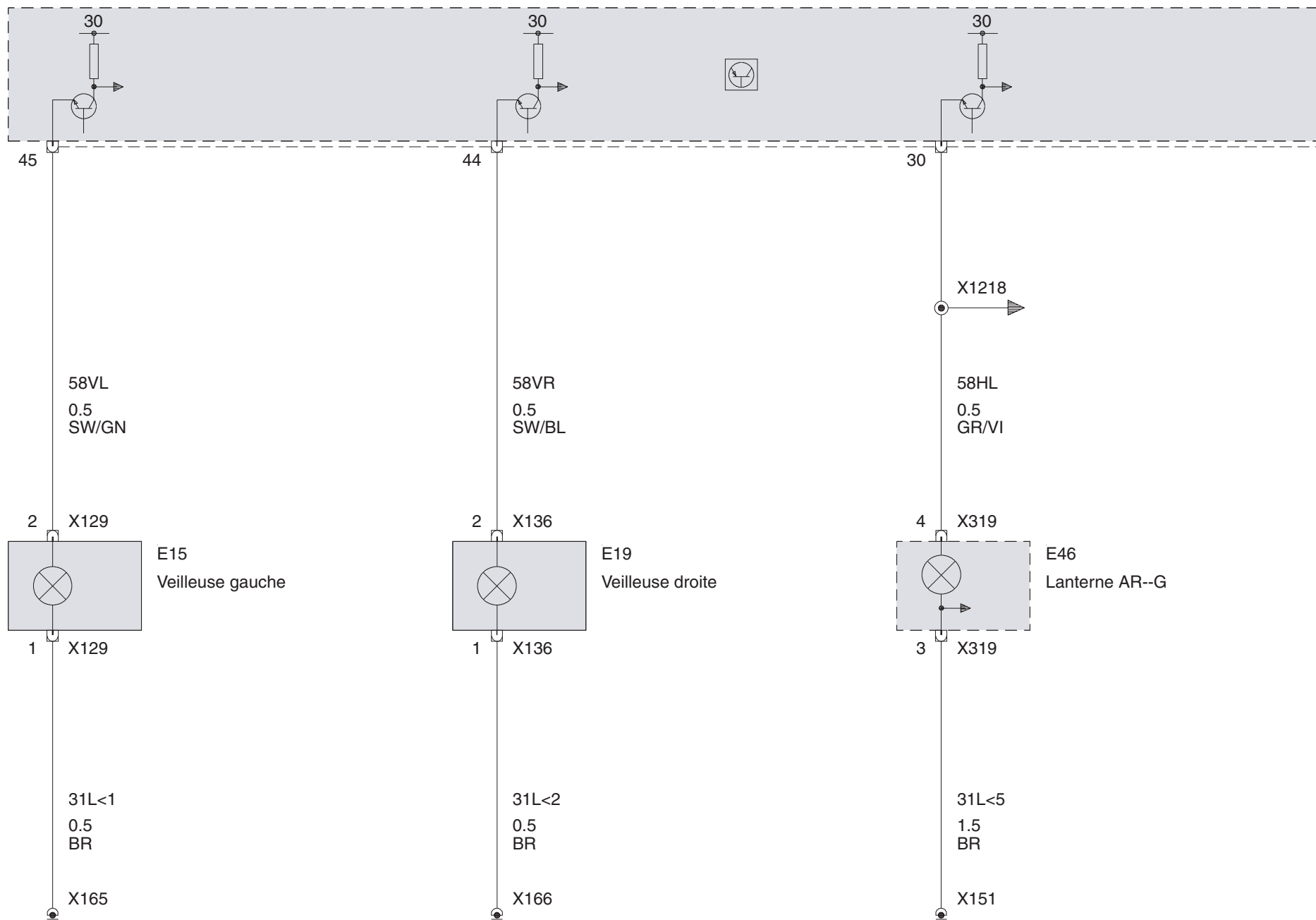

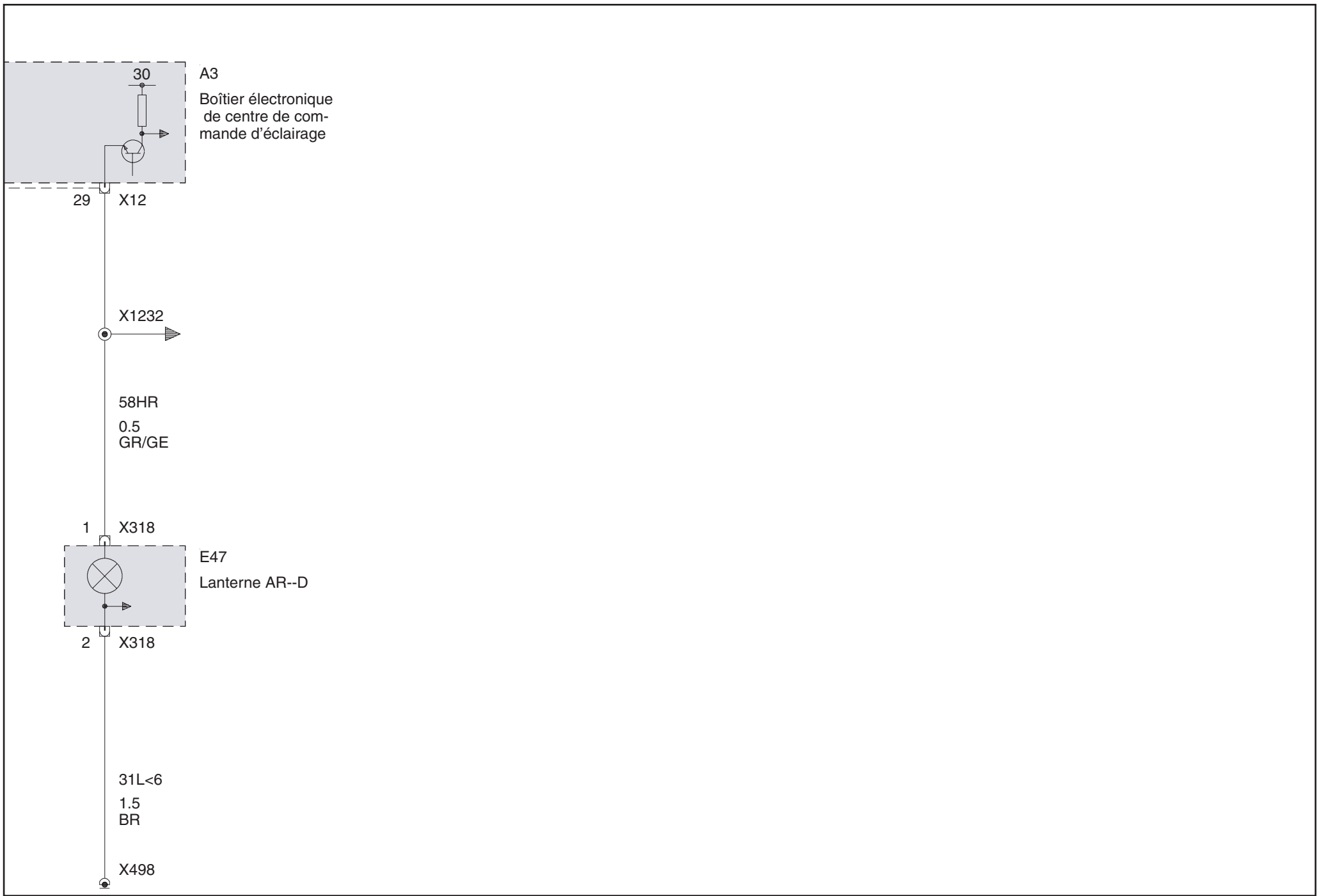

Feu de position (Compact)

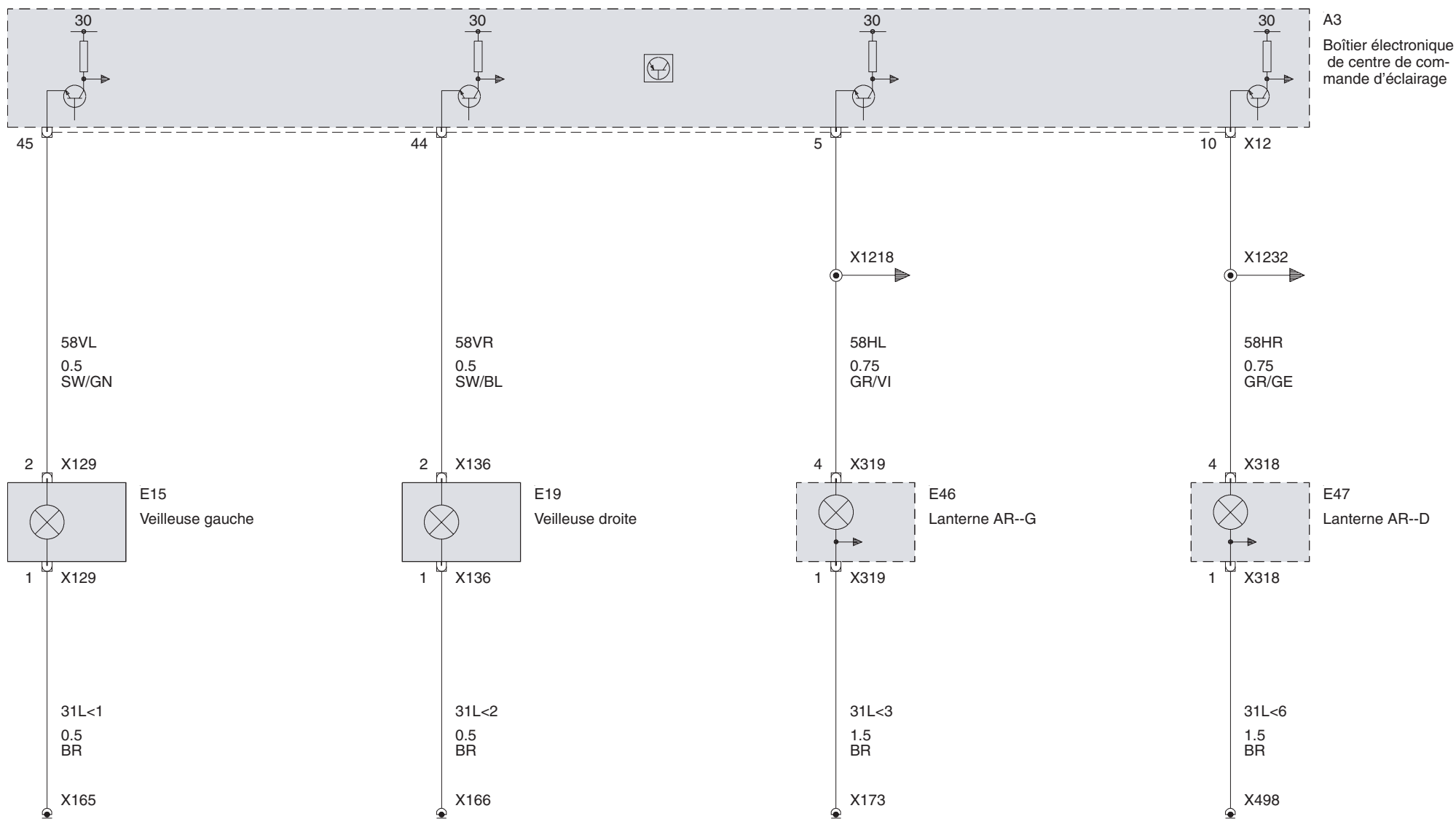

## Eclairage plaque immatriculation

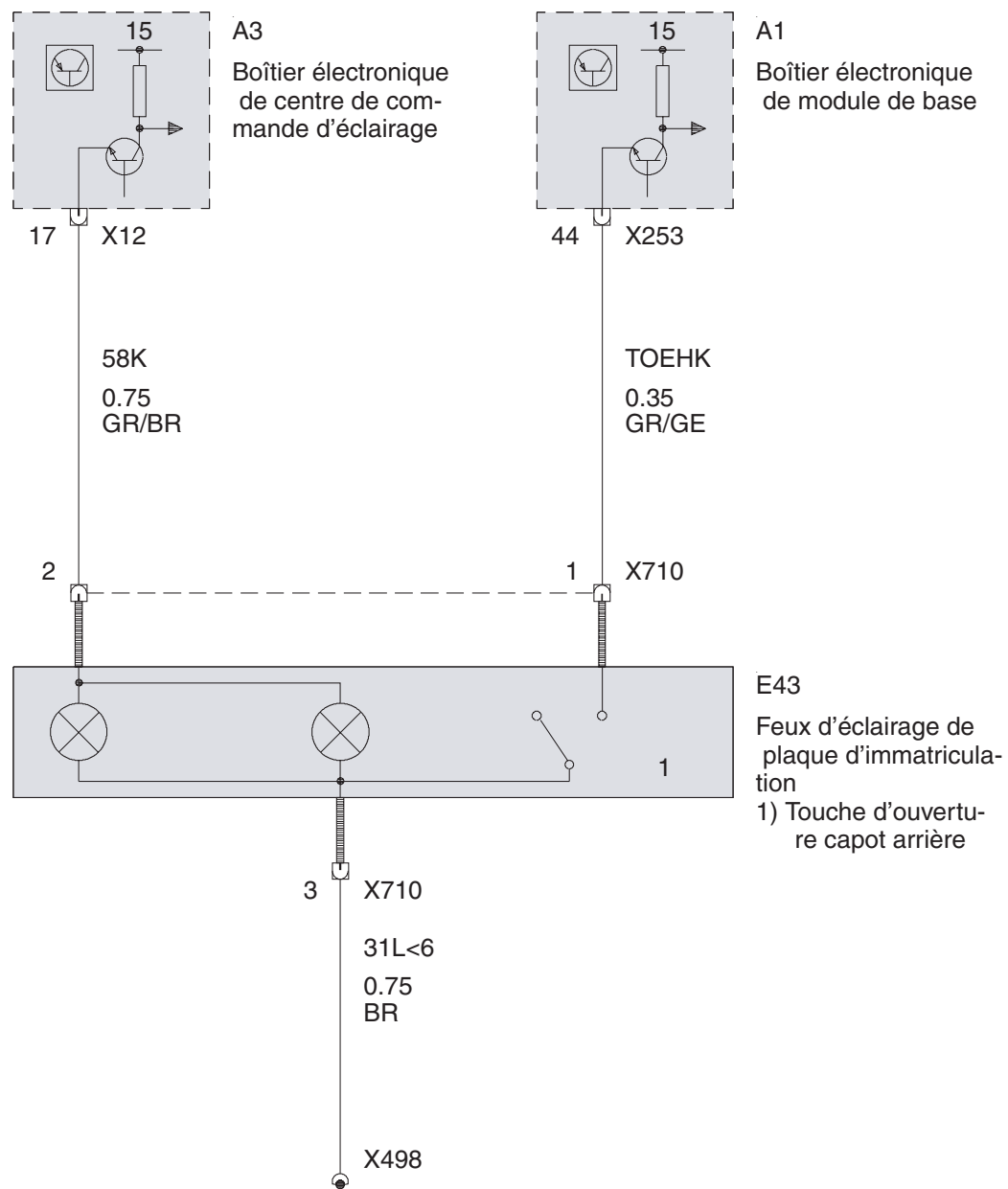



### Feux de croisement (sans Phare au xénon)

Feux de croisement (à partir de 2001\_09 jusque 2003\_03)

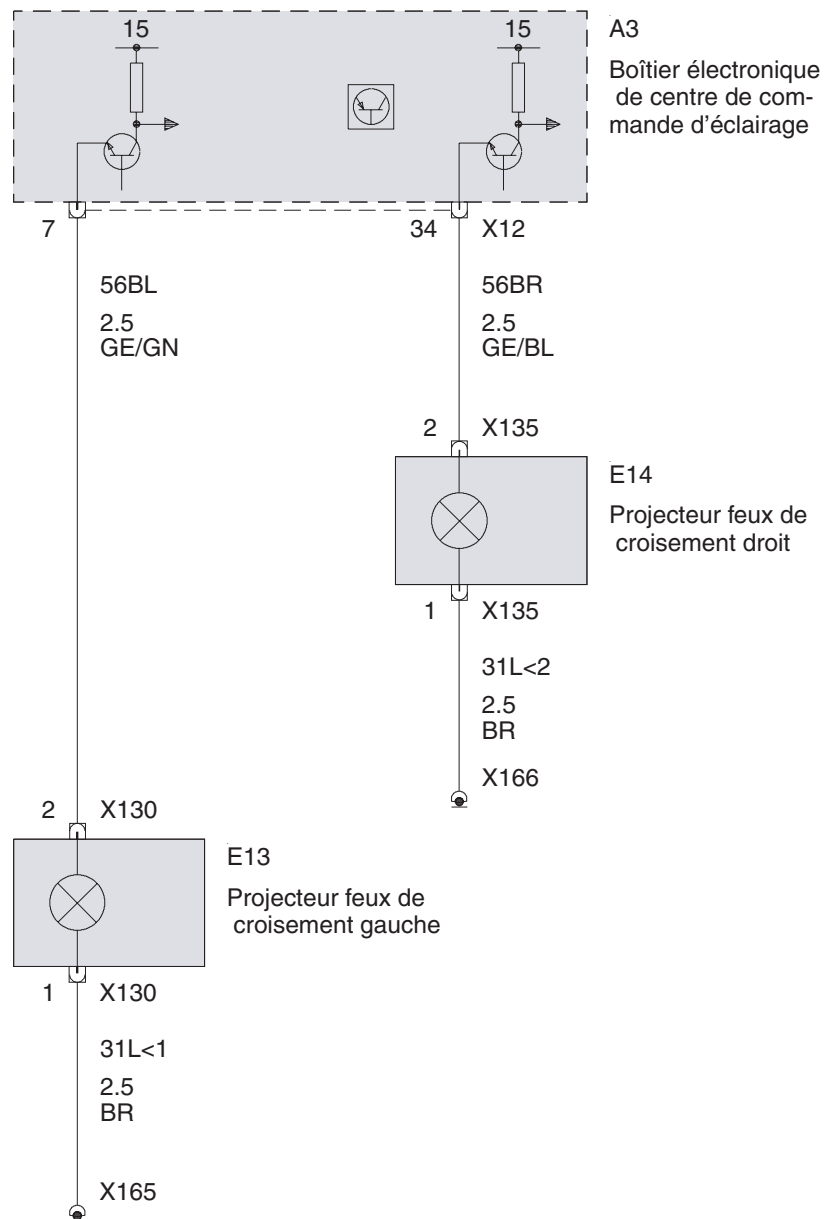

Feux de croisement (à partir de 2003\_03)

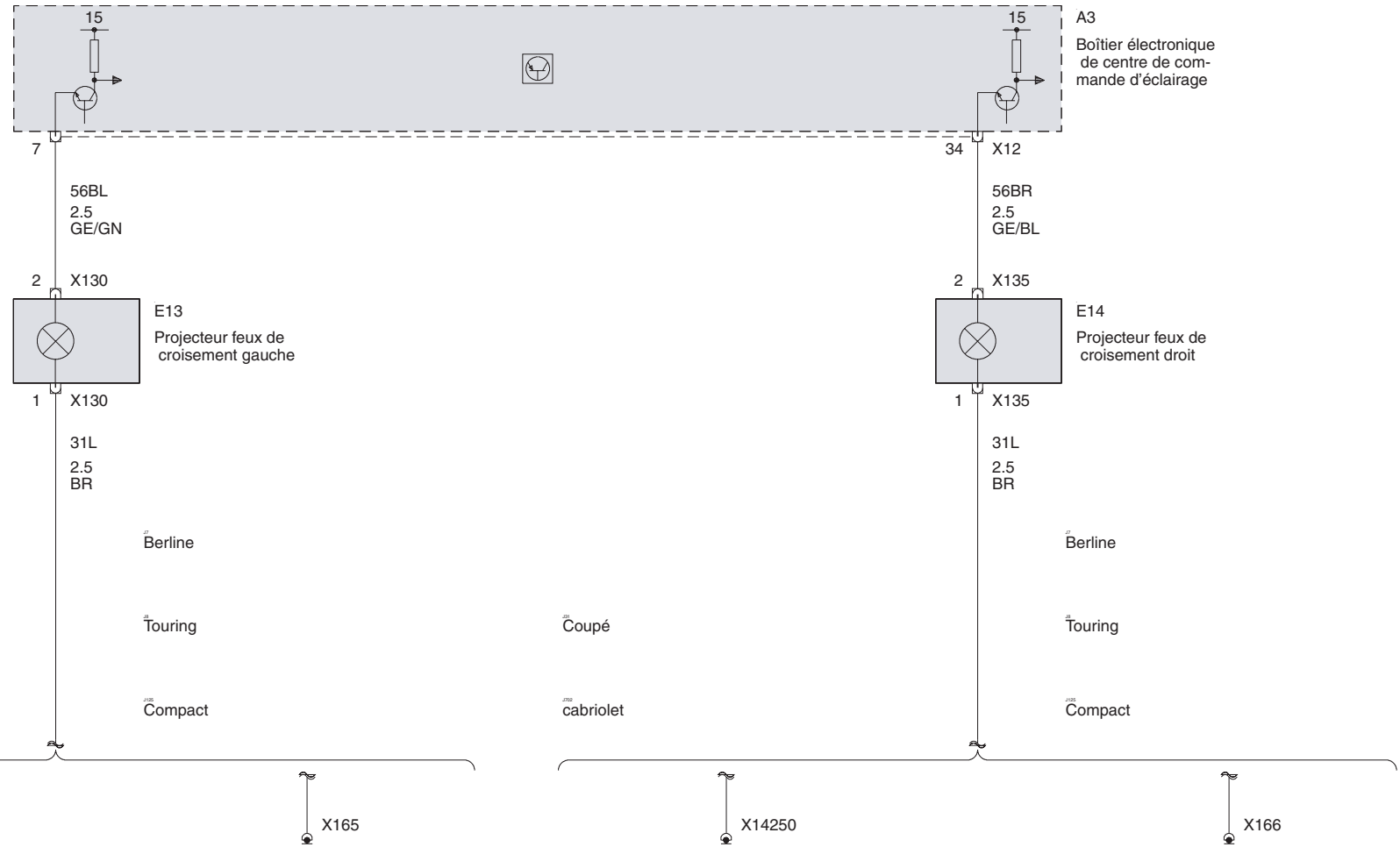

Eclairage au xénon (à partir de 2001\_03)

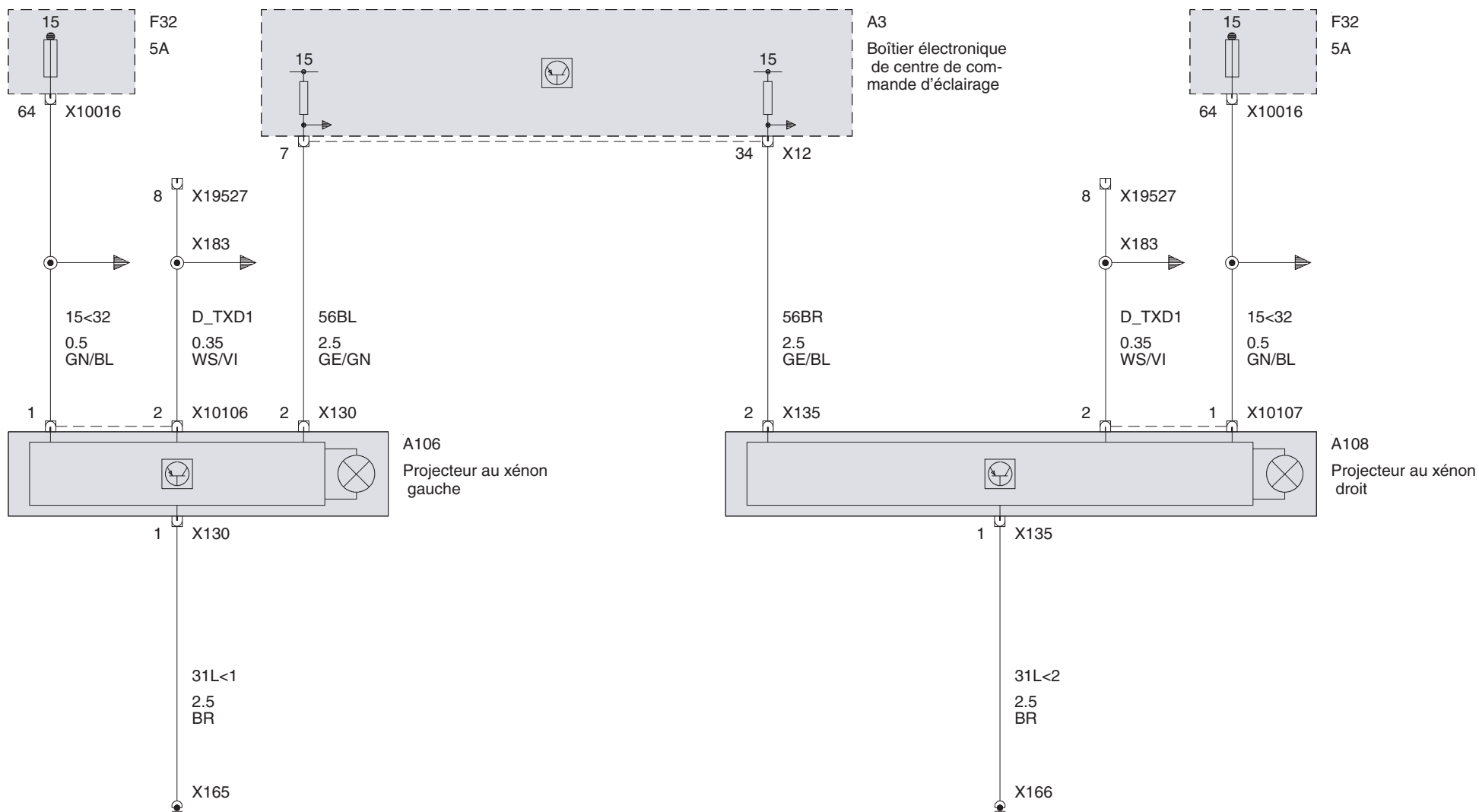

**Projecteur bi-xénon**  
Connecteur X183

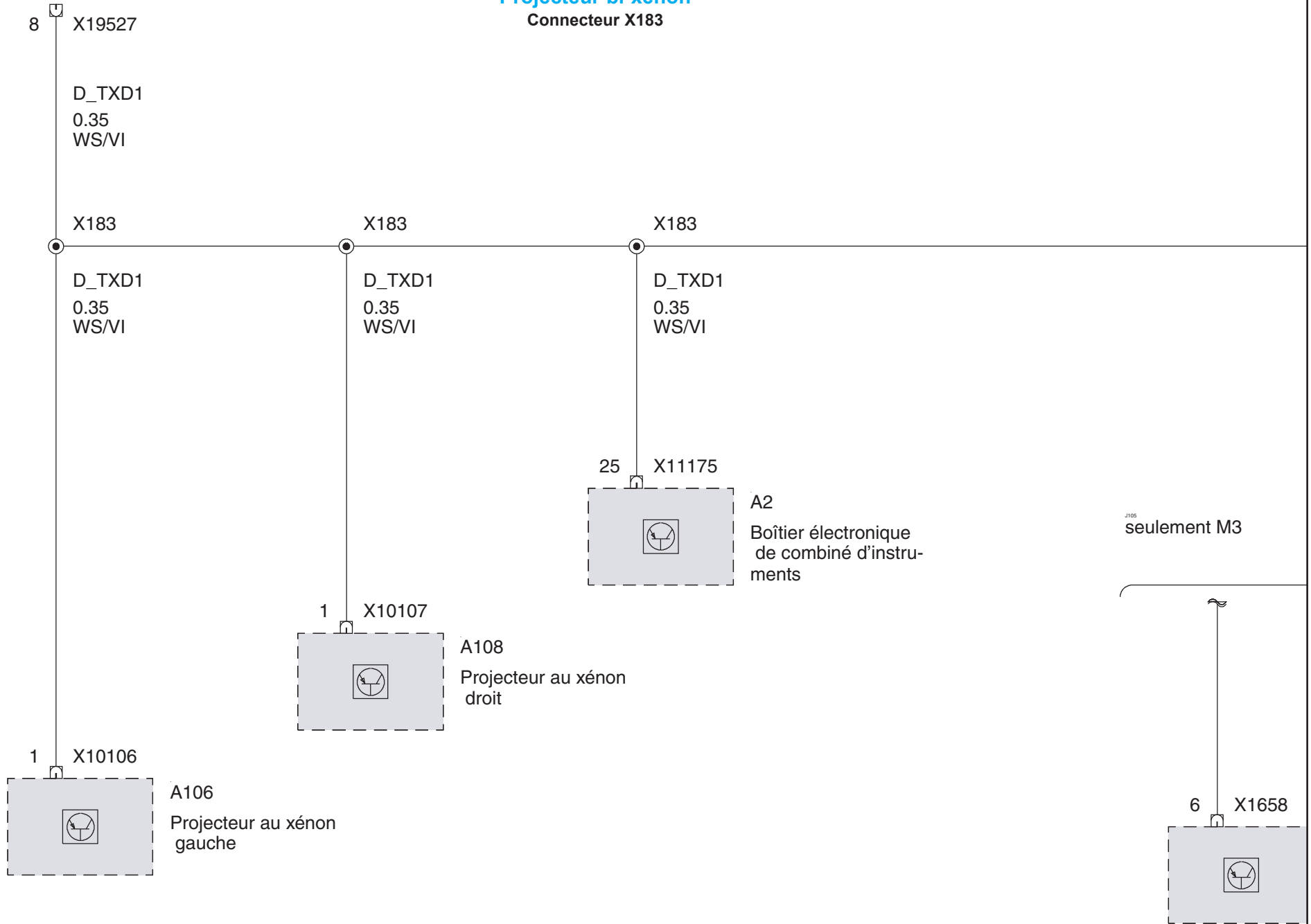

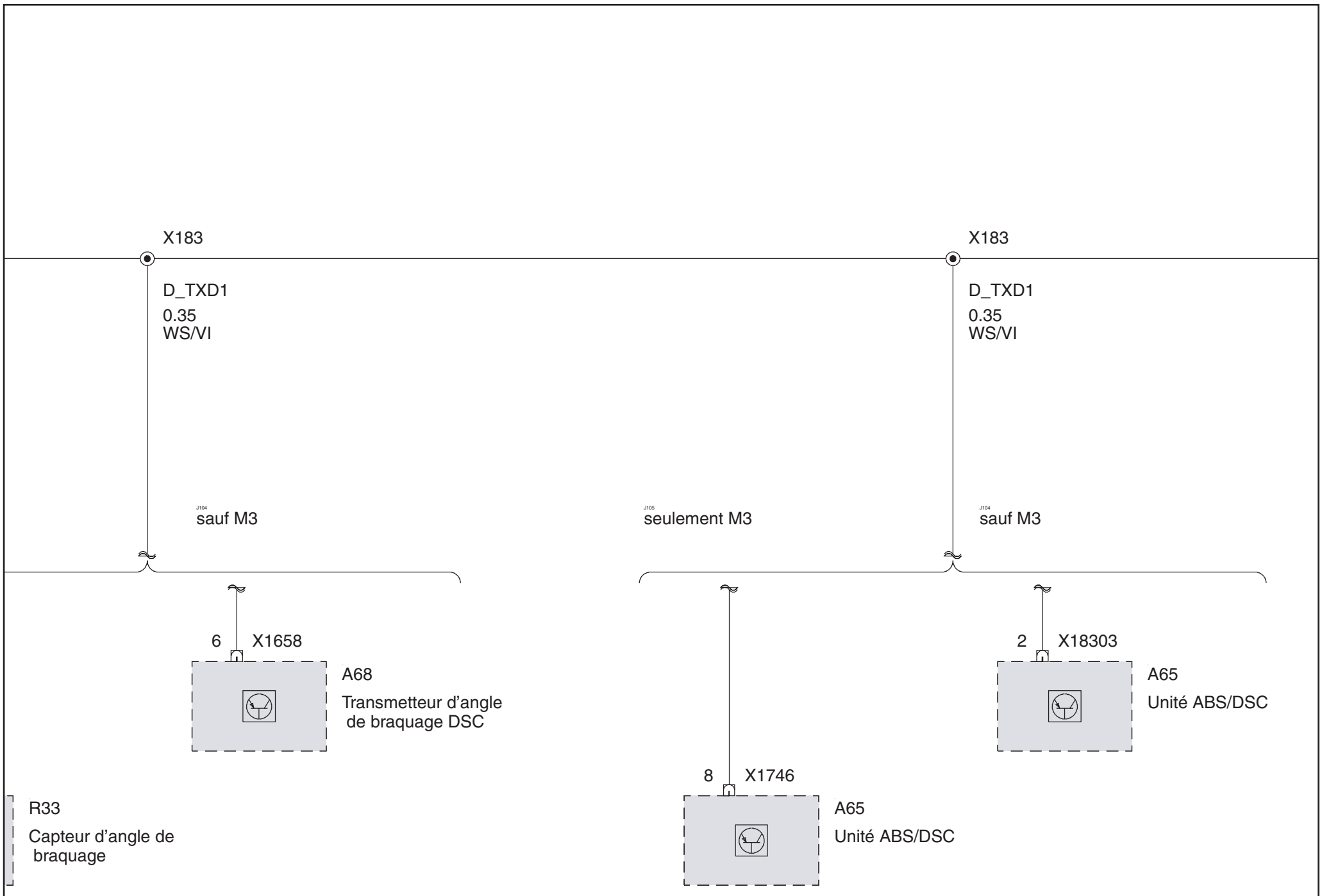

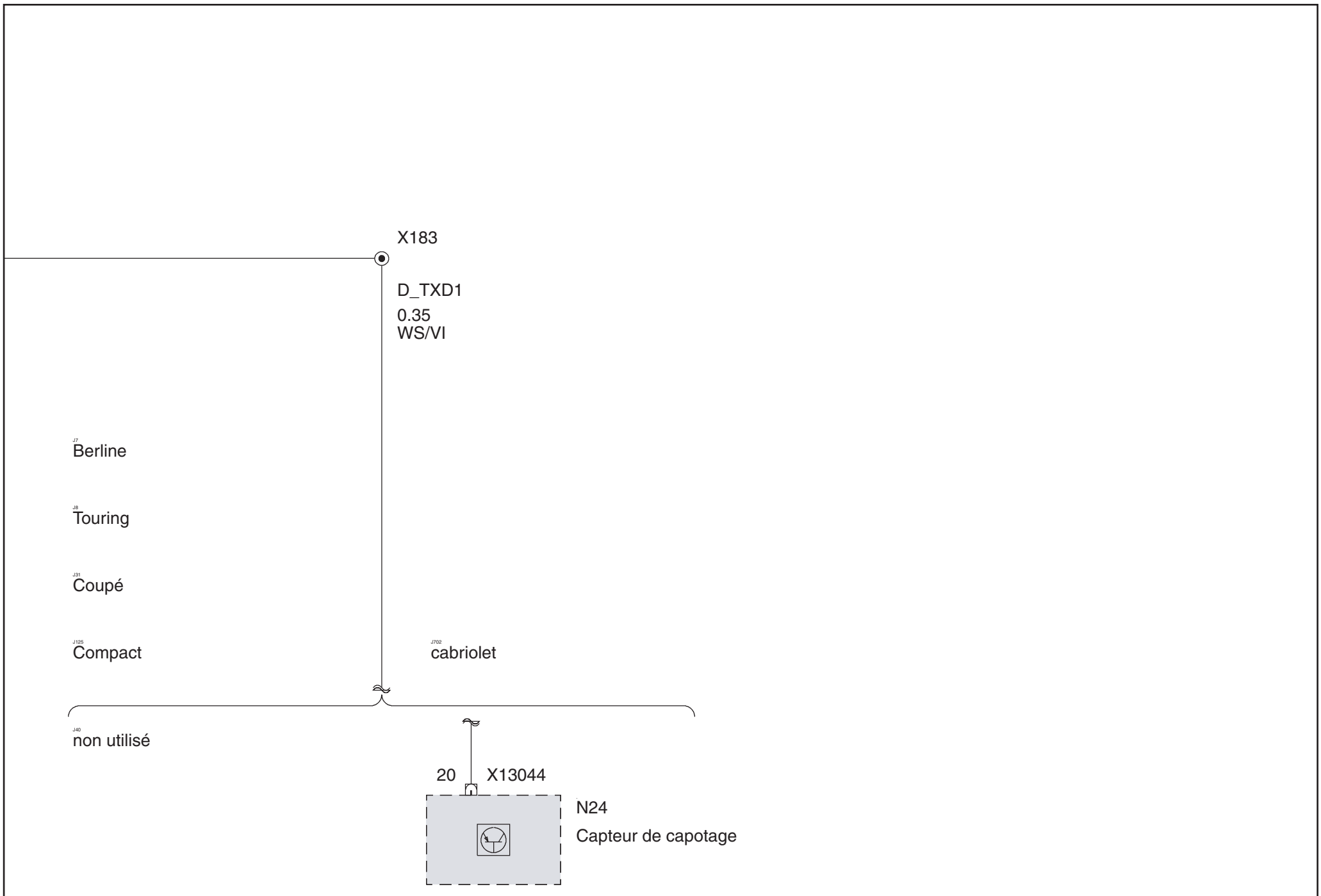

Eclairage bi-xénon (jusque 2003\_03)

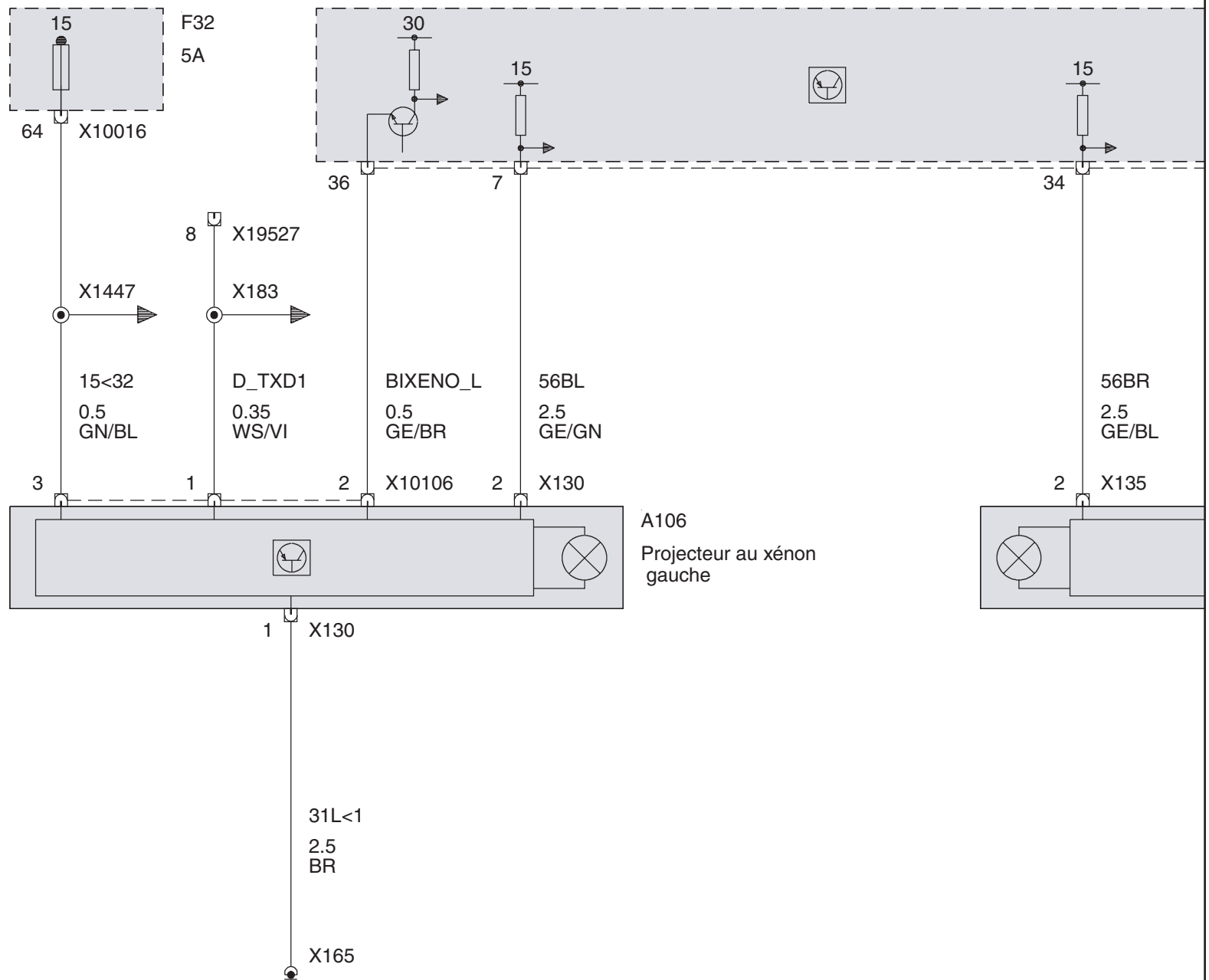

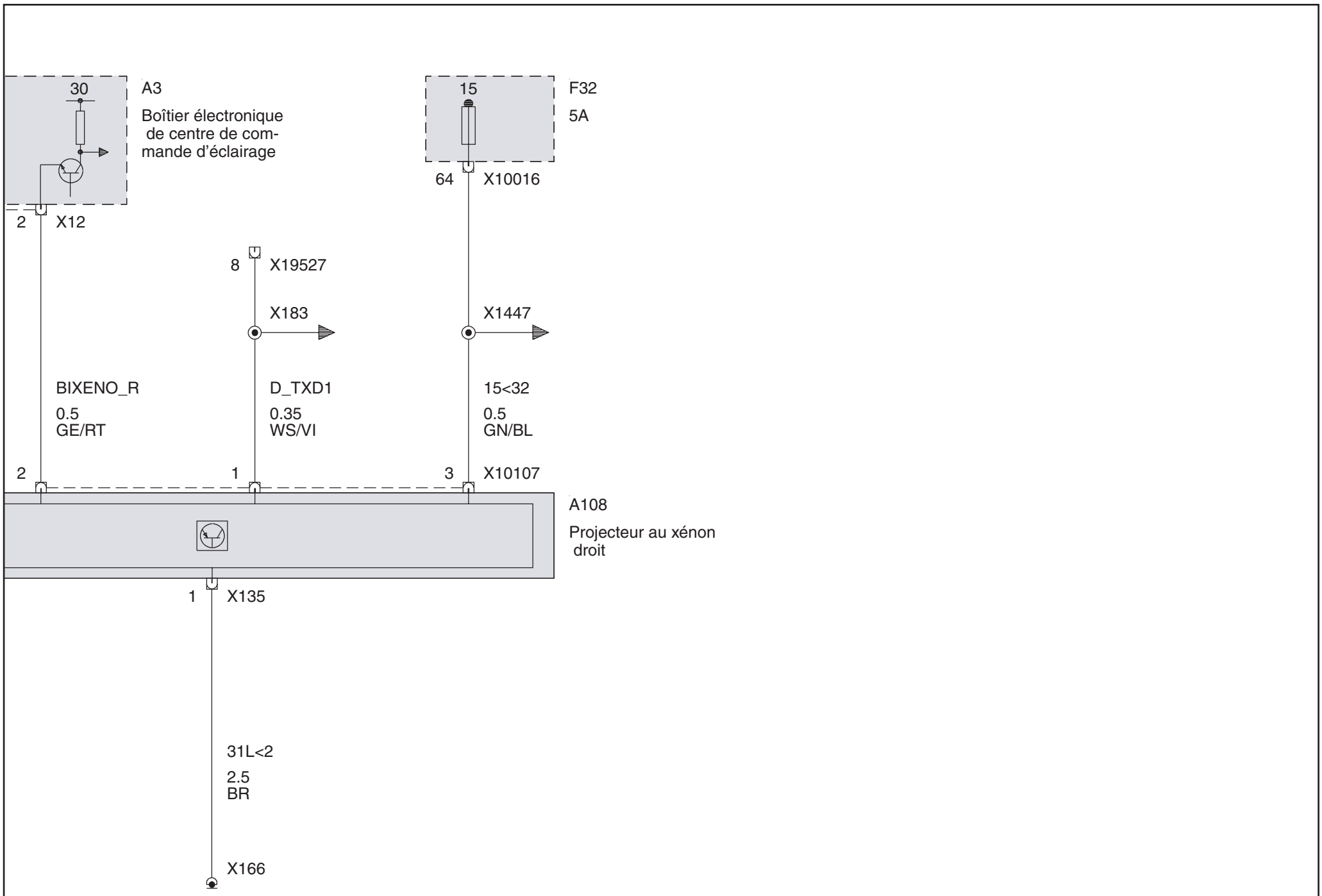



Eclairage bi-xénon (à partir de 2003\_03 jusque 2003\_09)

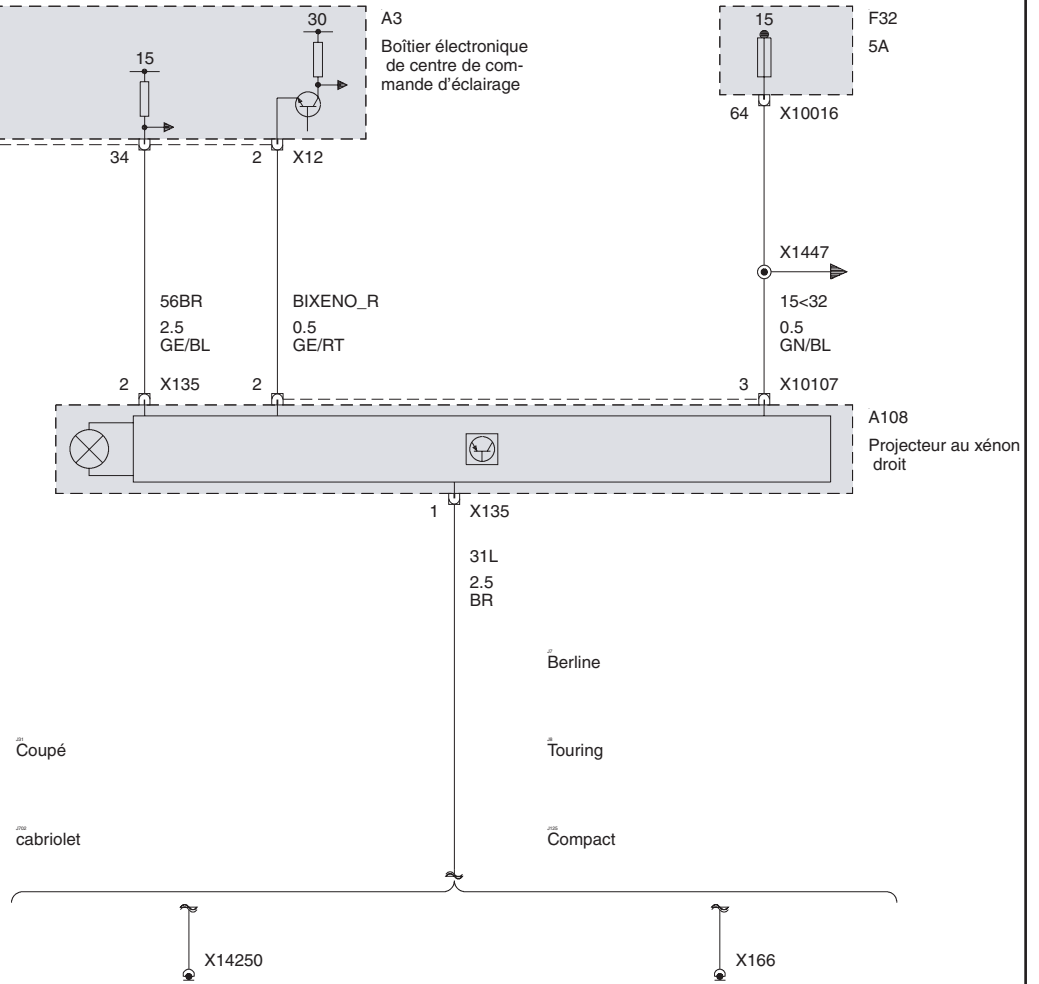
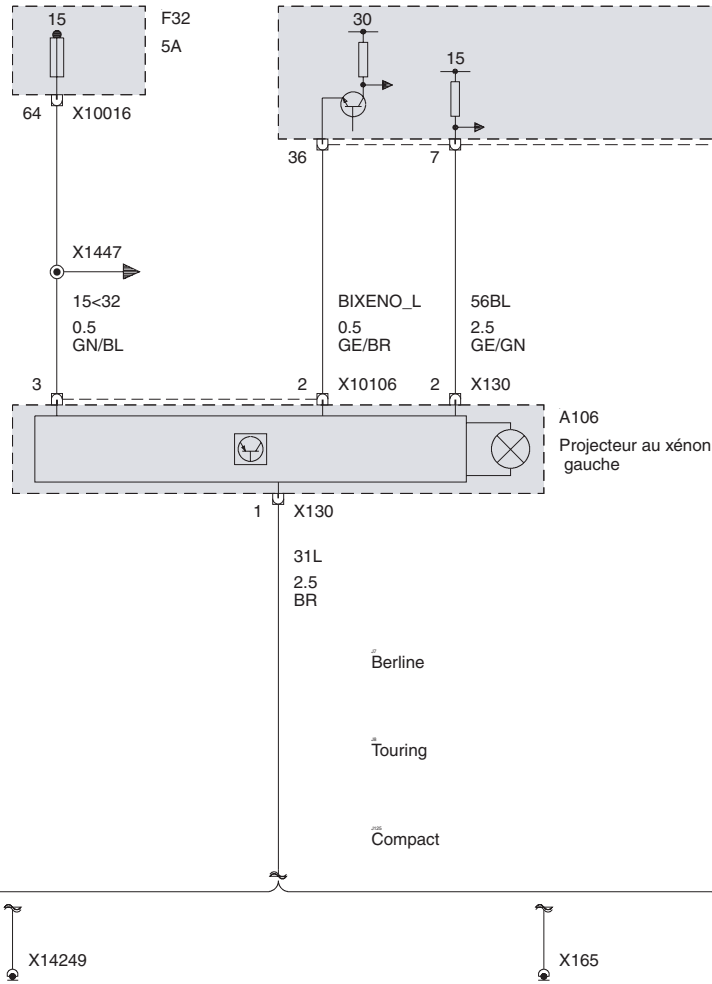

Eclairage bi-xénon (à partir de 2003\_09)

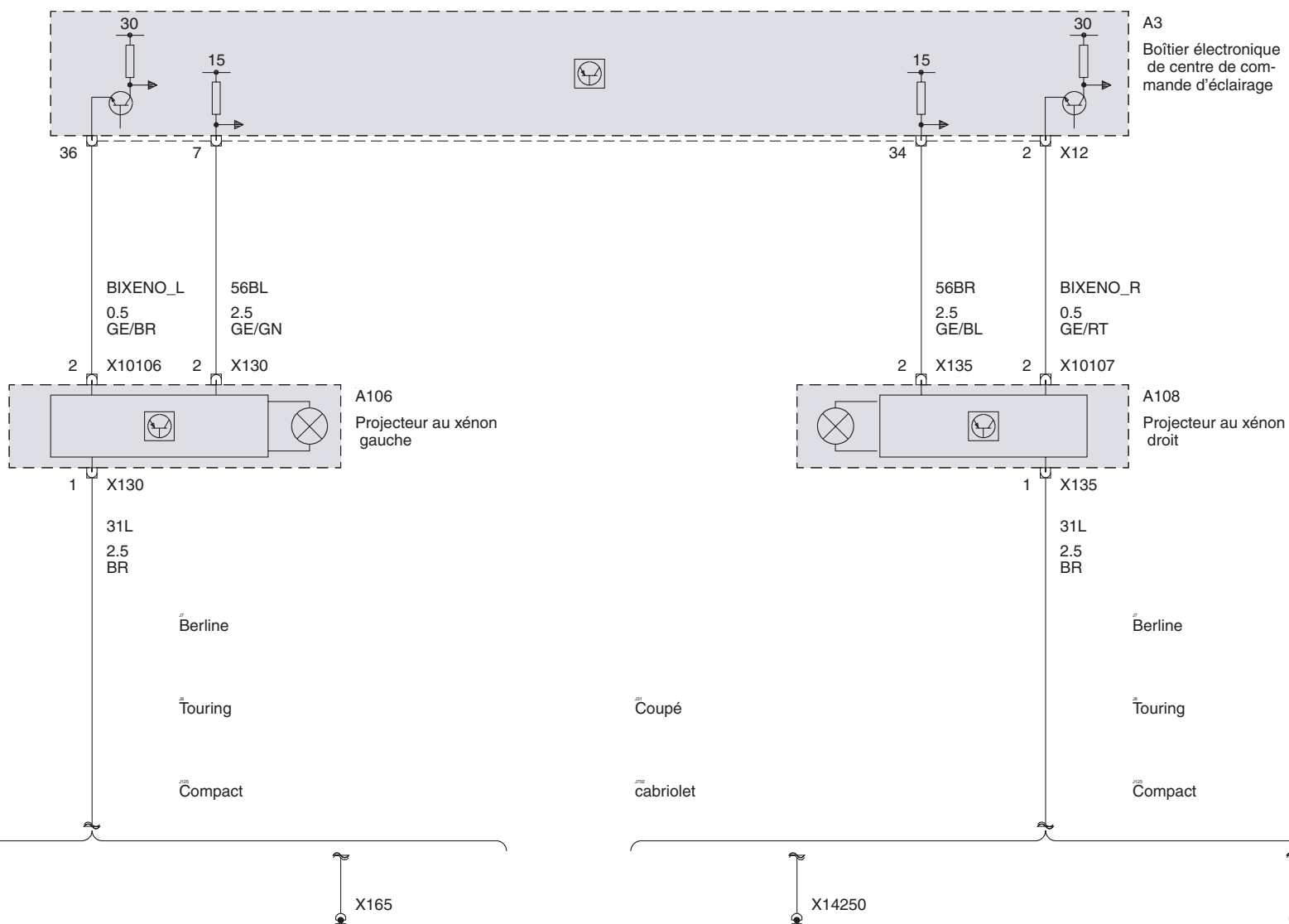

**Projecteur pleins phares**  
Feu de route (jusque 2003\_03)

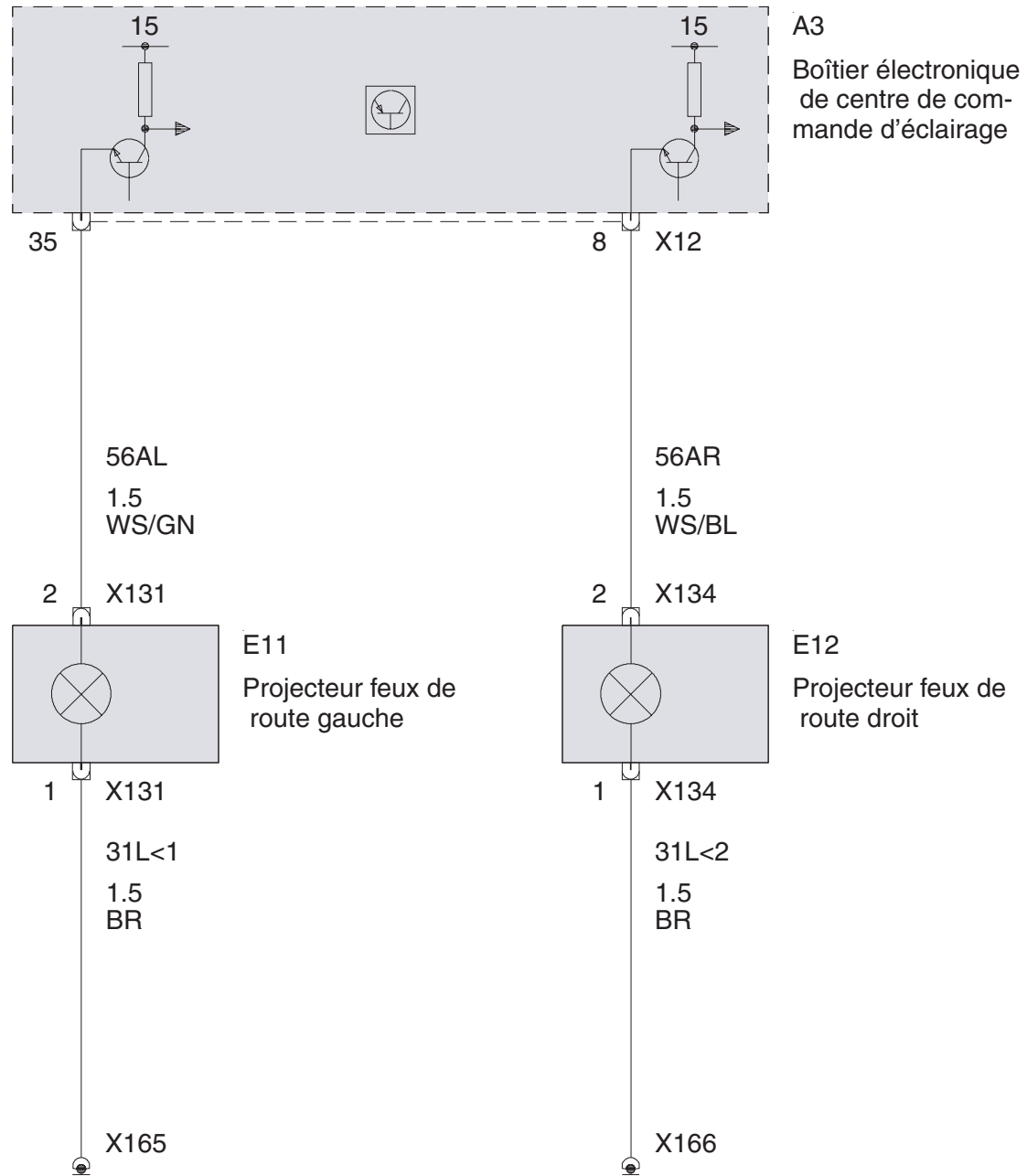

Feu de route (à partir de 2003\_03)

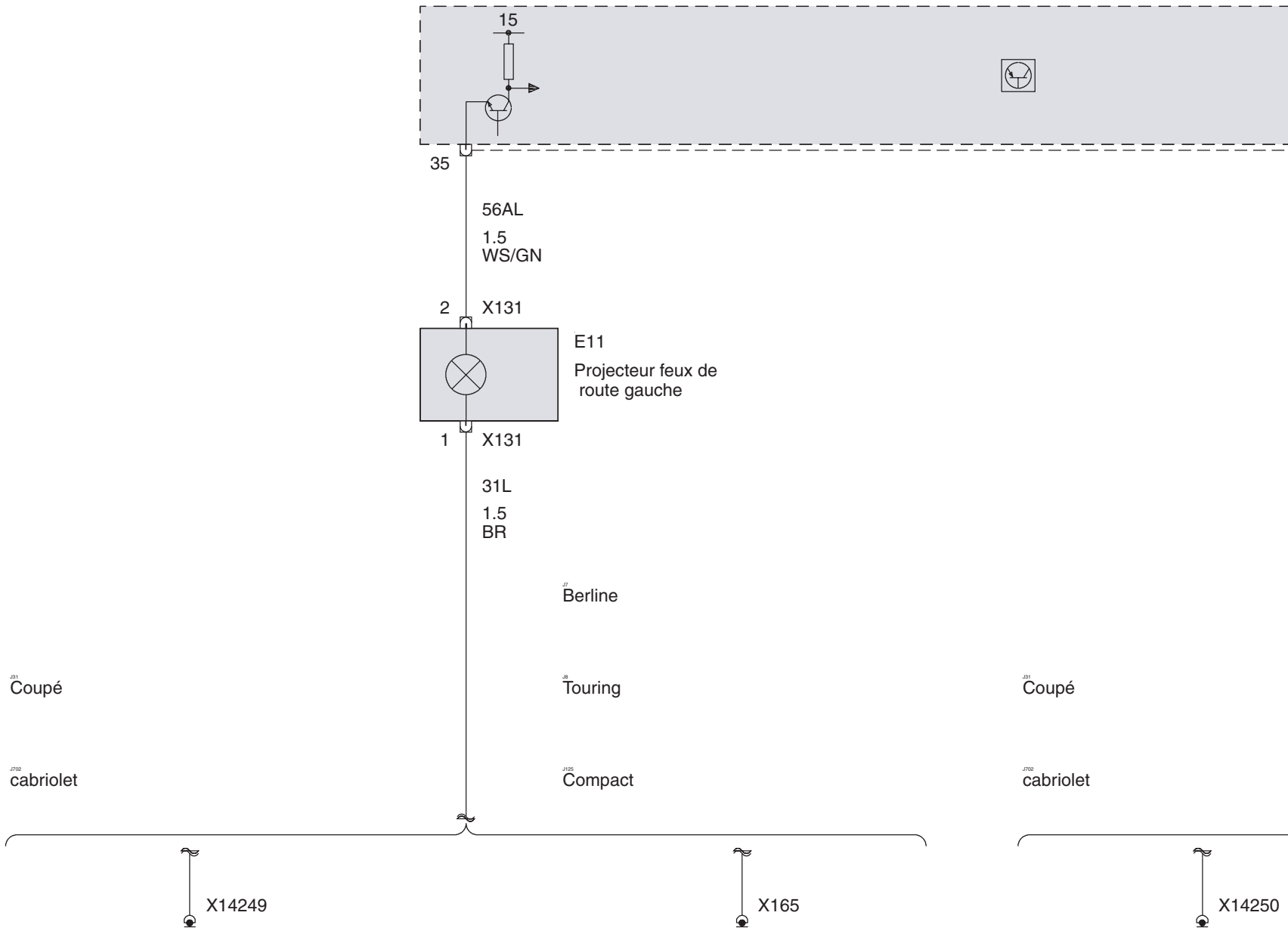

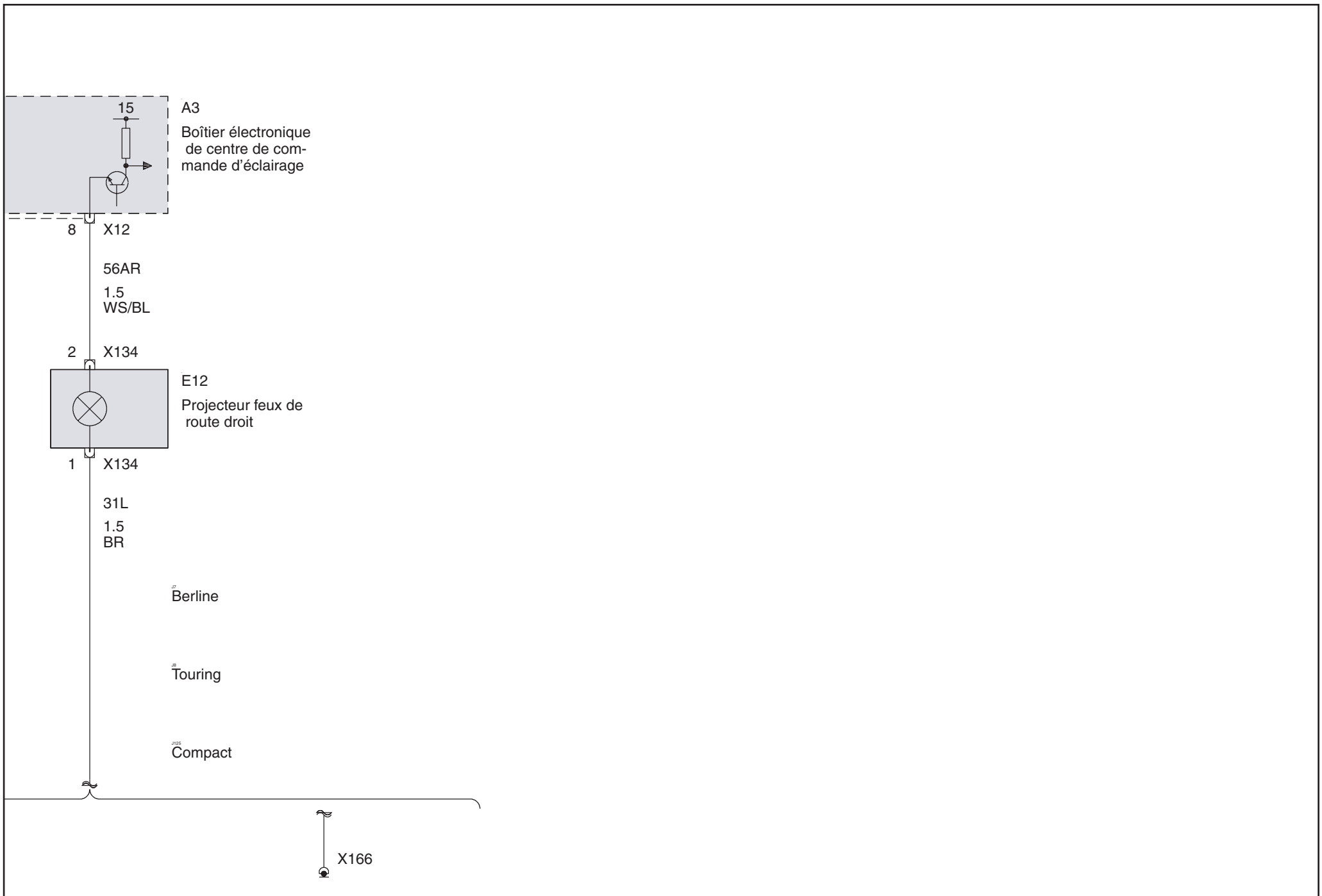

**Correcteur de portée d'éclairage**  
 Réglage manuel de site des projecteurs (sans Eclairage au xénon)

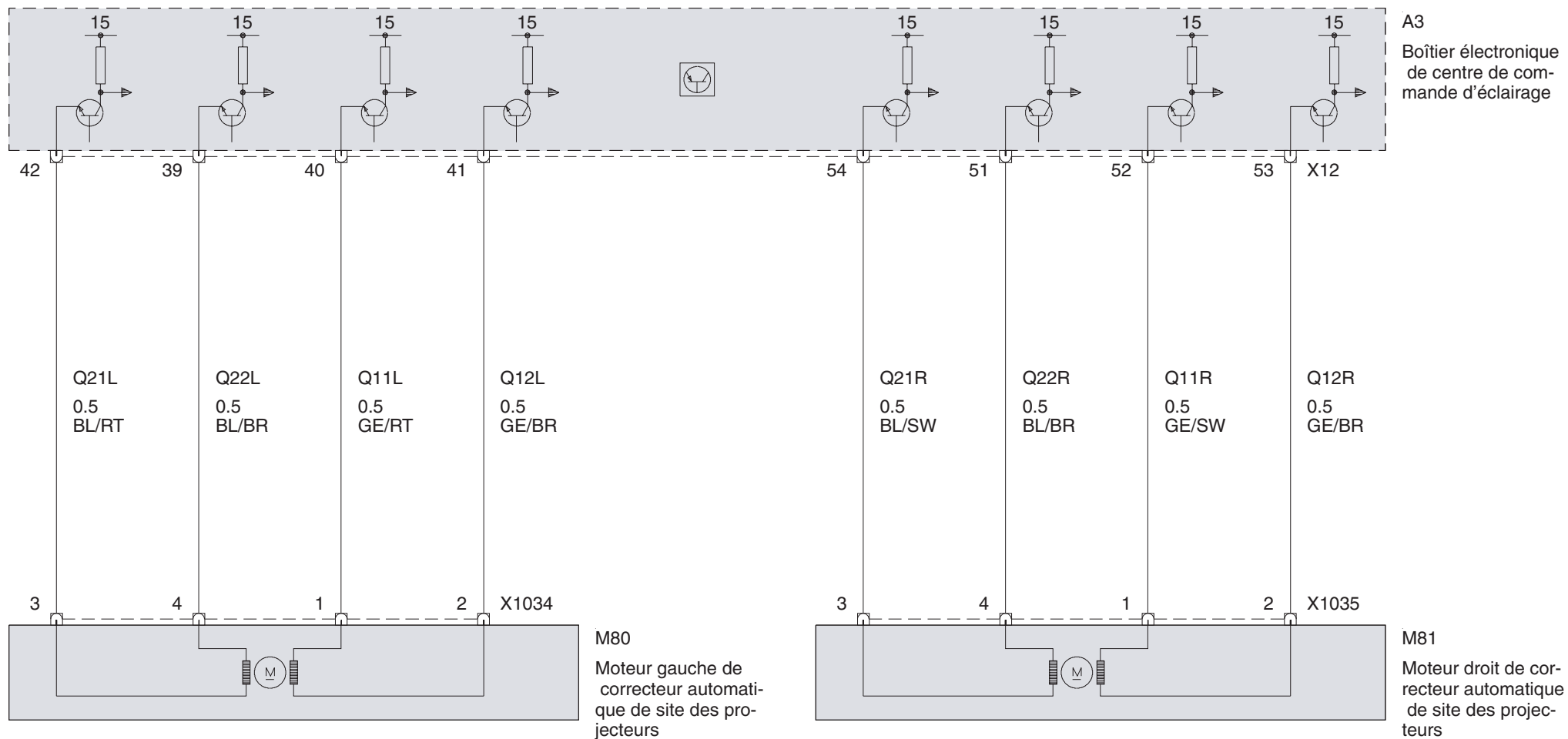

Réglage automatique de site des projecteurs (Eclairage au xénon)

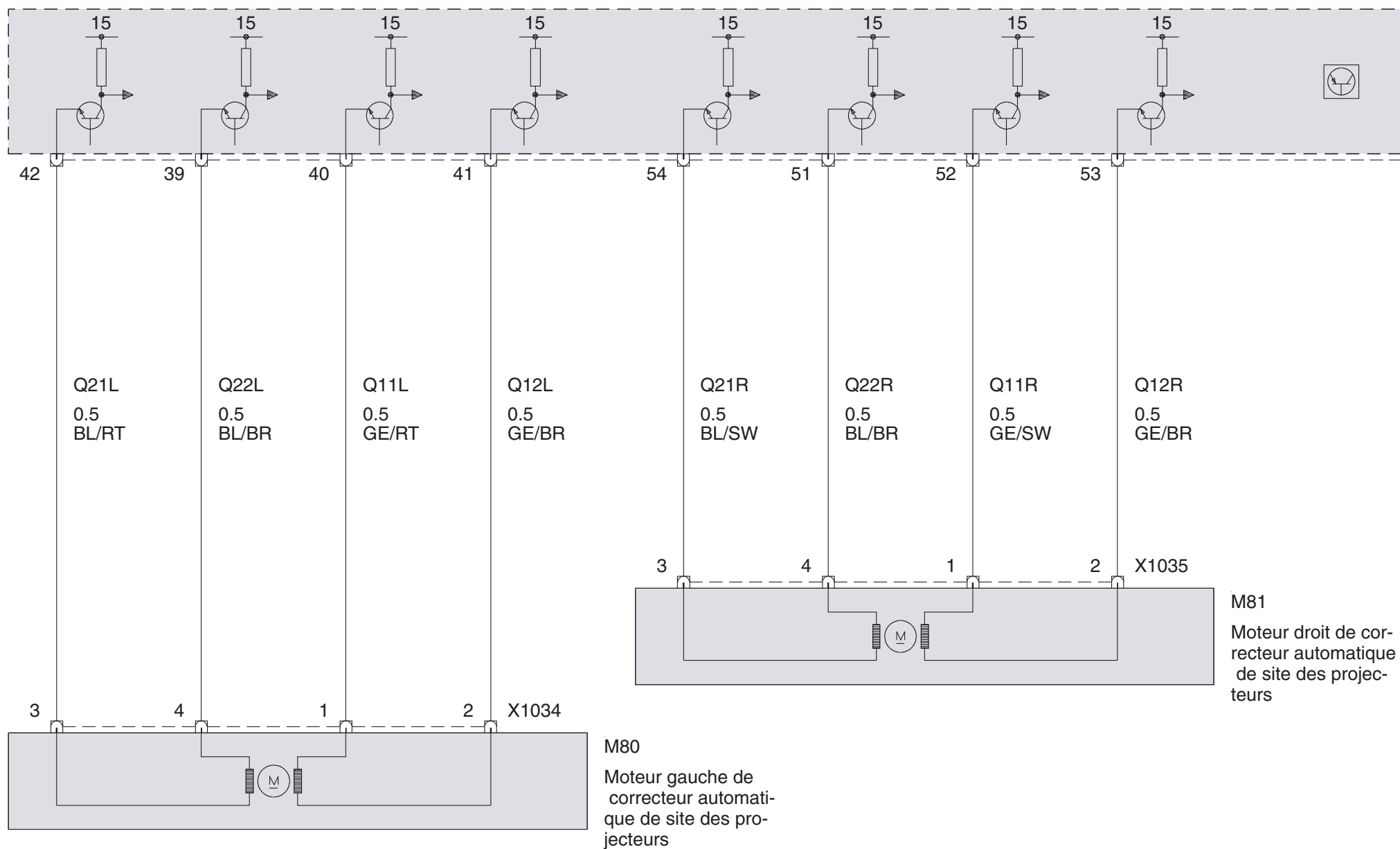

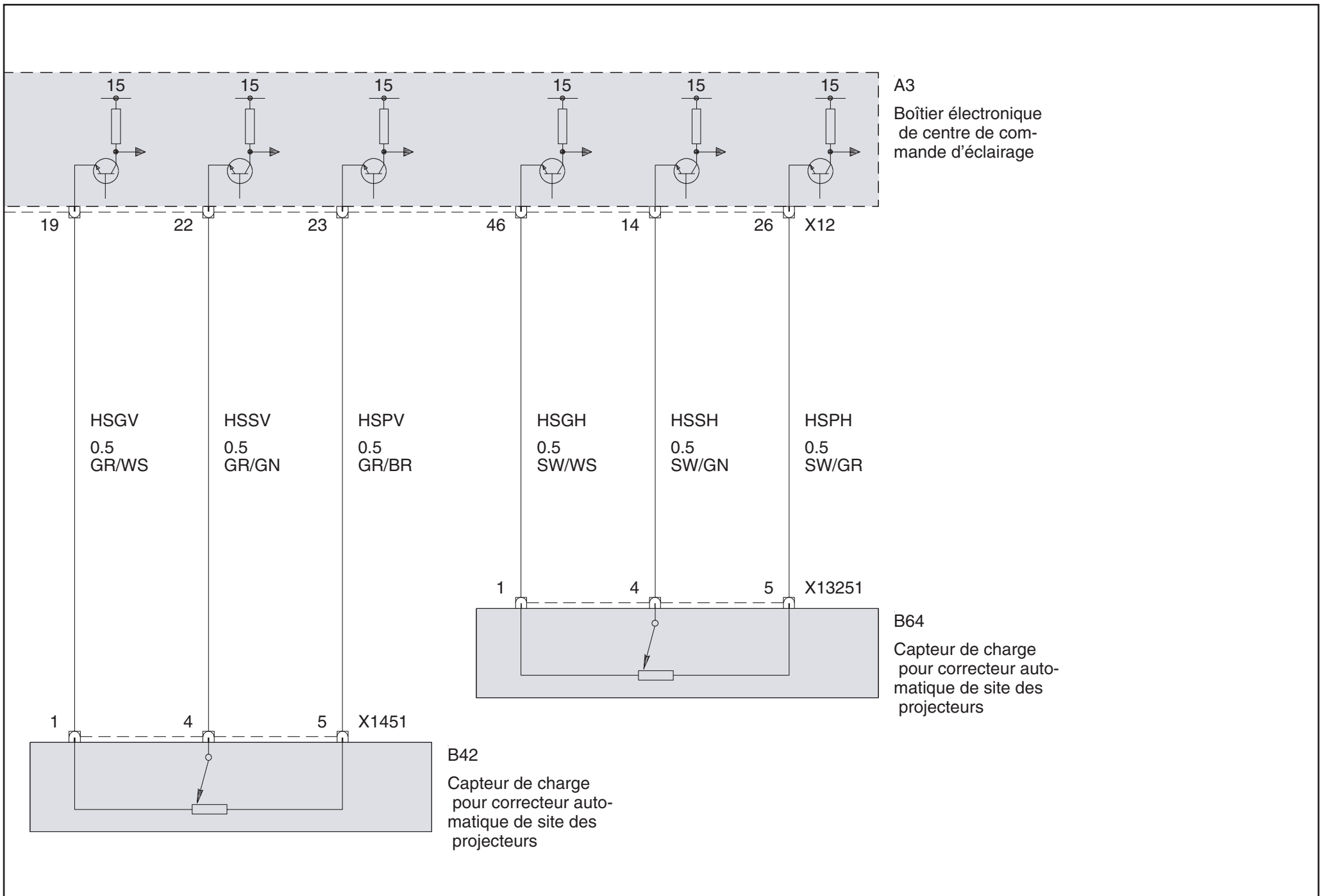



Eclairage des virages / correction de site des projecteurs (AHL Eclairage de virage adaptatif)

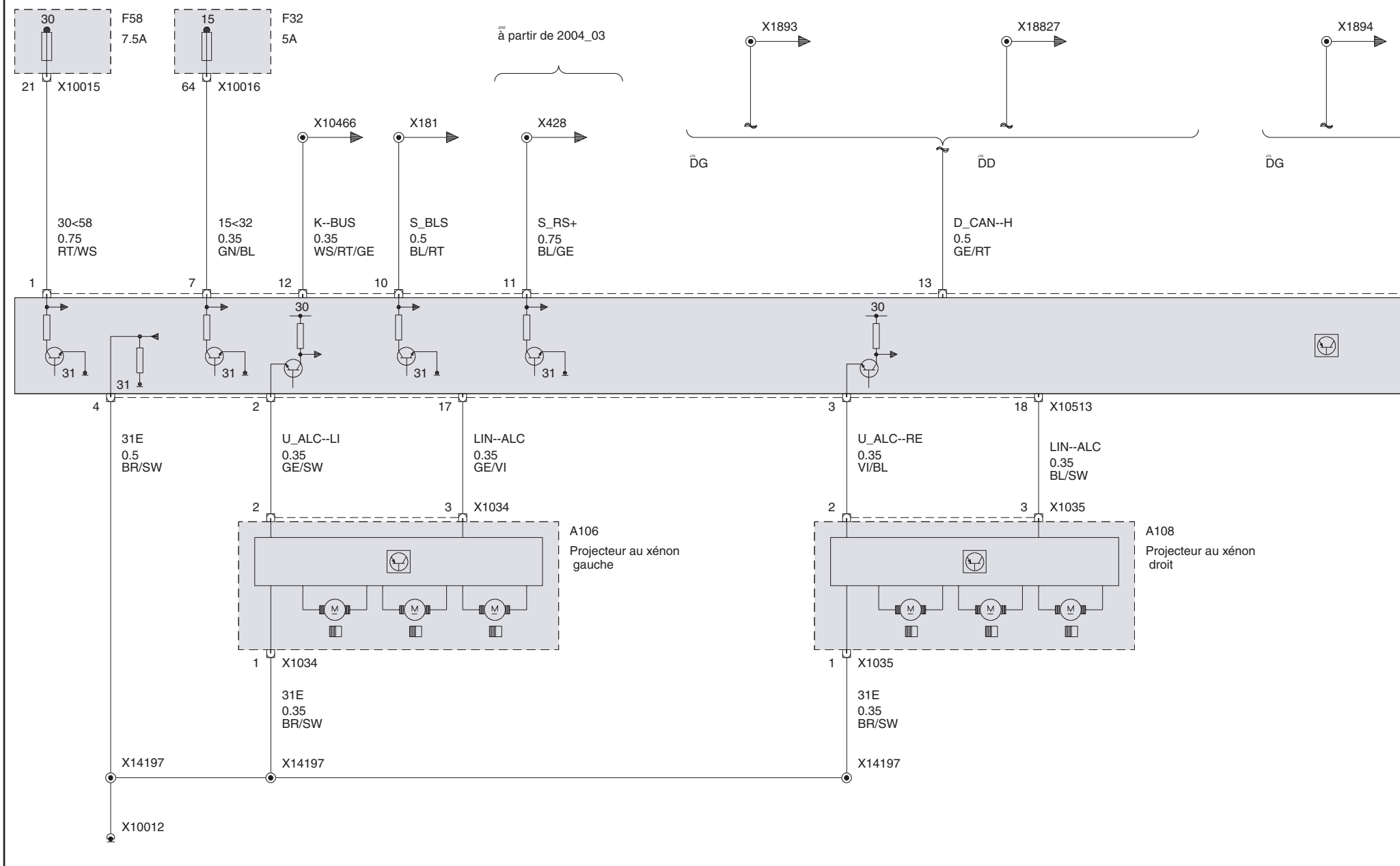

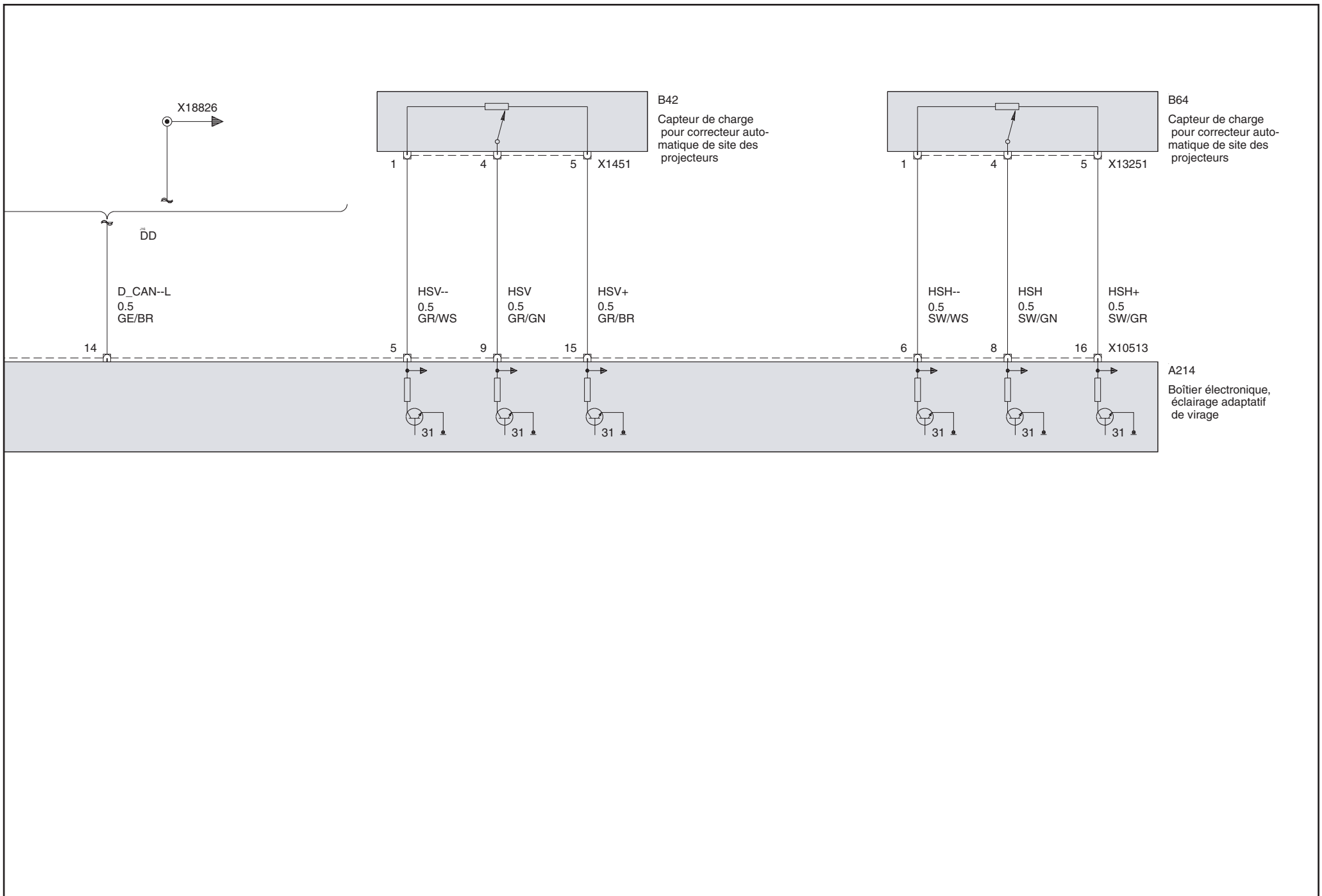

Capteur pluie/feux de croisement (RLS Capteur de pluie/d'éclairage)

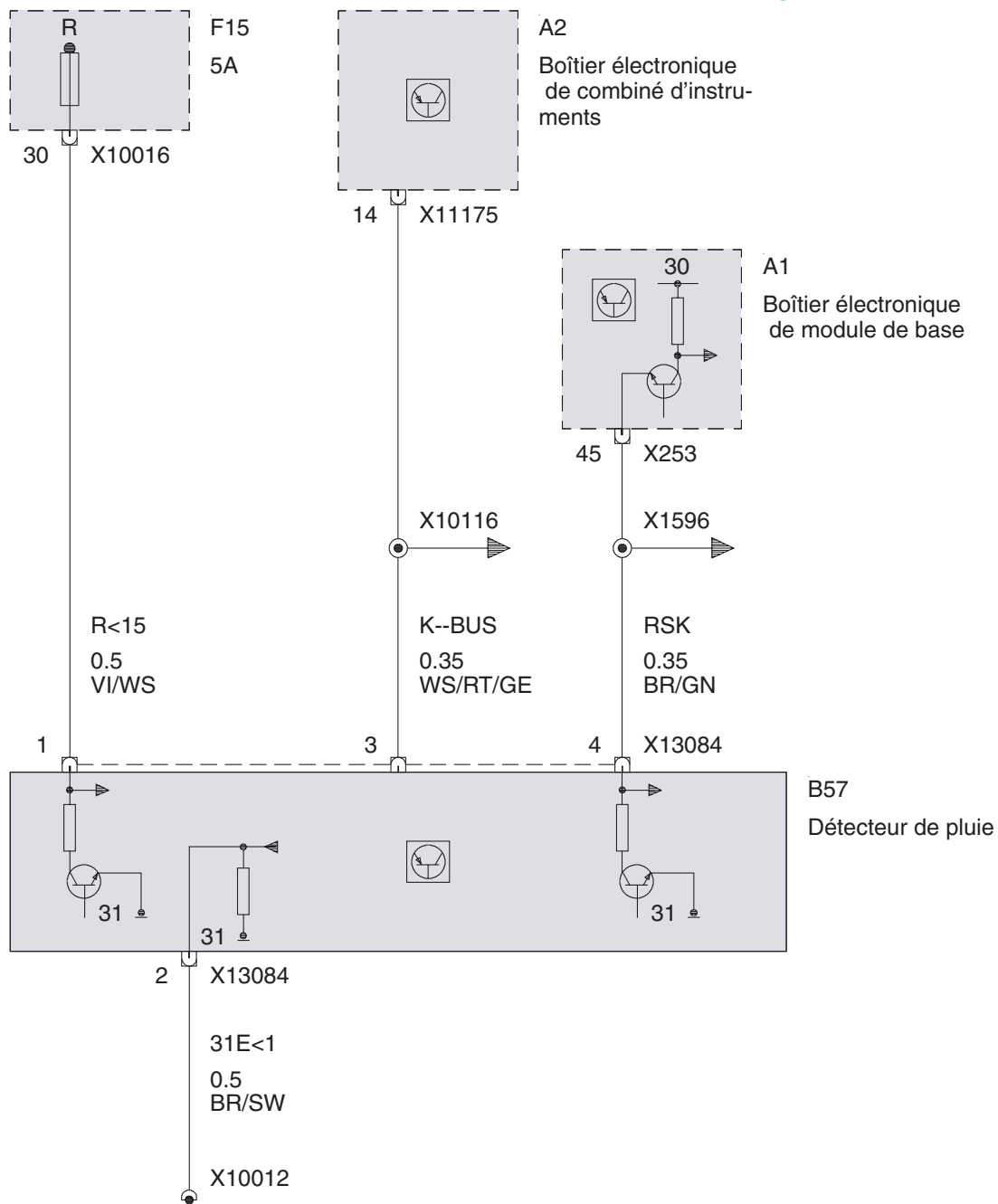

Feu stop

Contacteur de feux stop (( DME Electronique moteur MS43 ou ME9) sans Transmission intégrale, sans SMG Boîte de vitesses manuelle séquentielle)

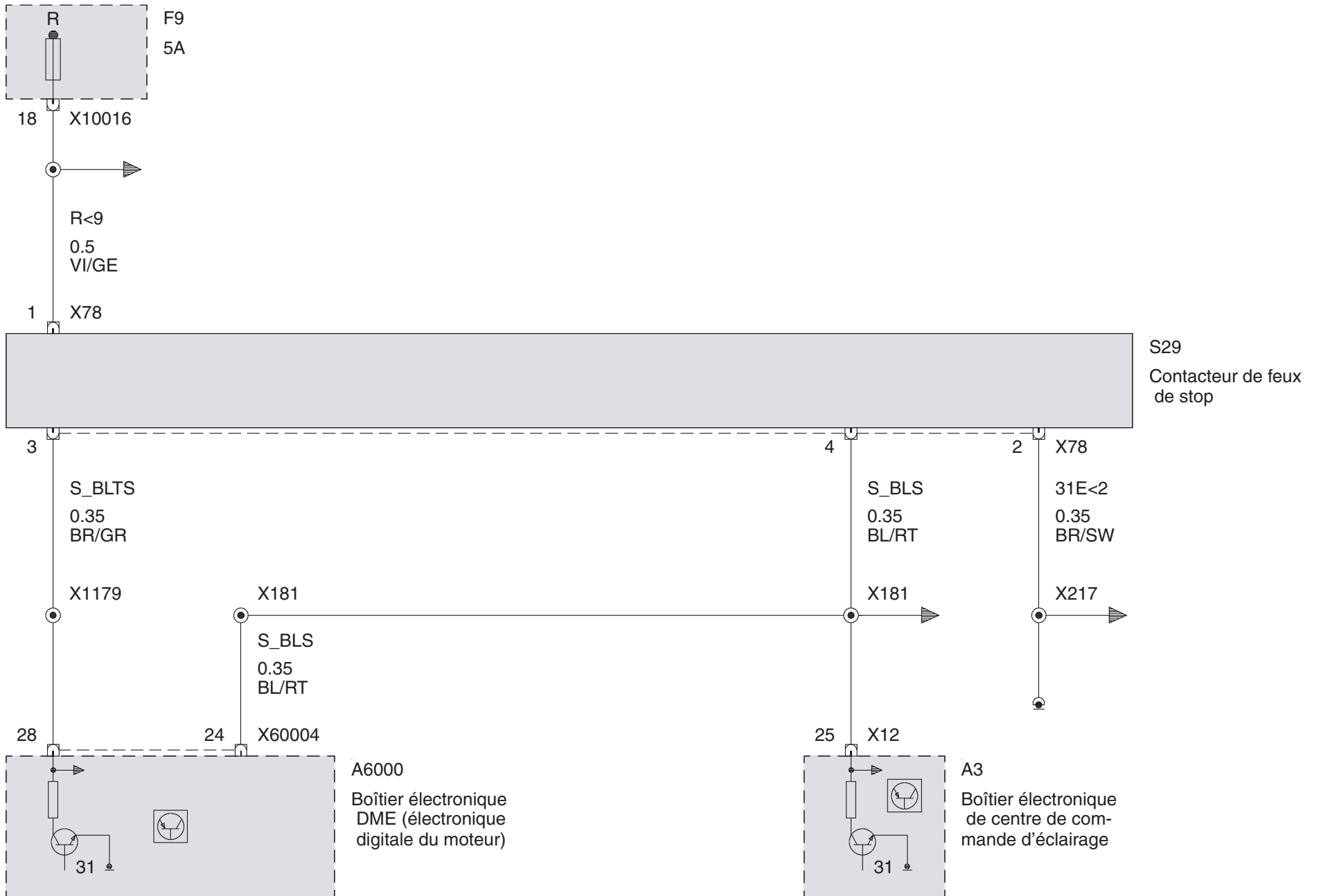

Contacteur de feux stop (DDE Electronique Diesel DDE50)

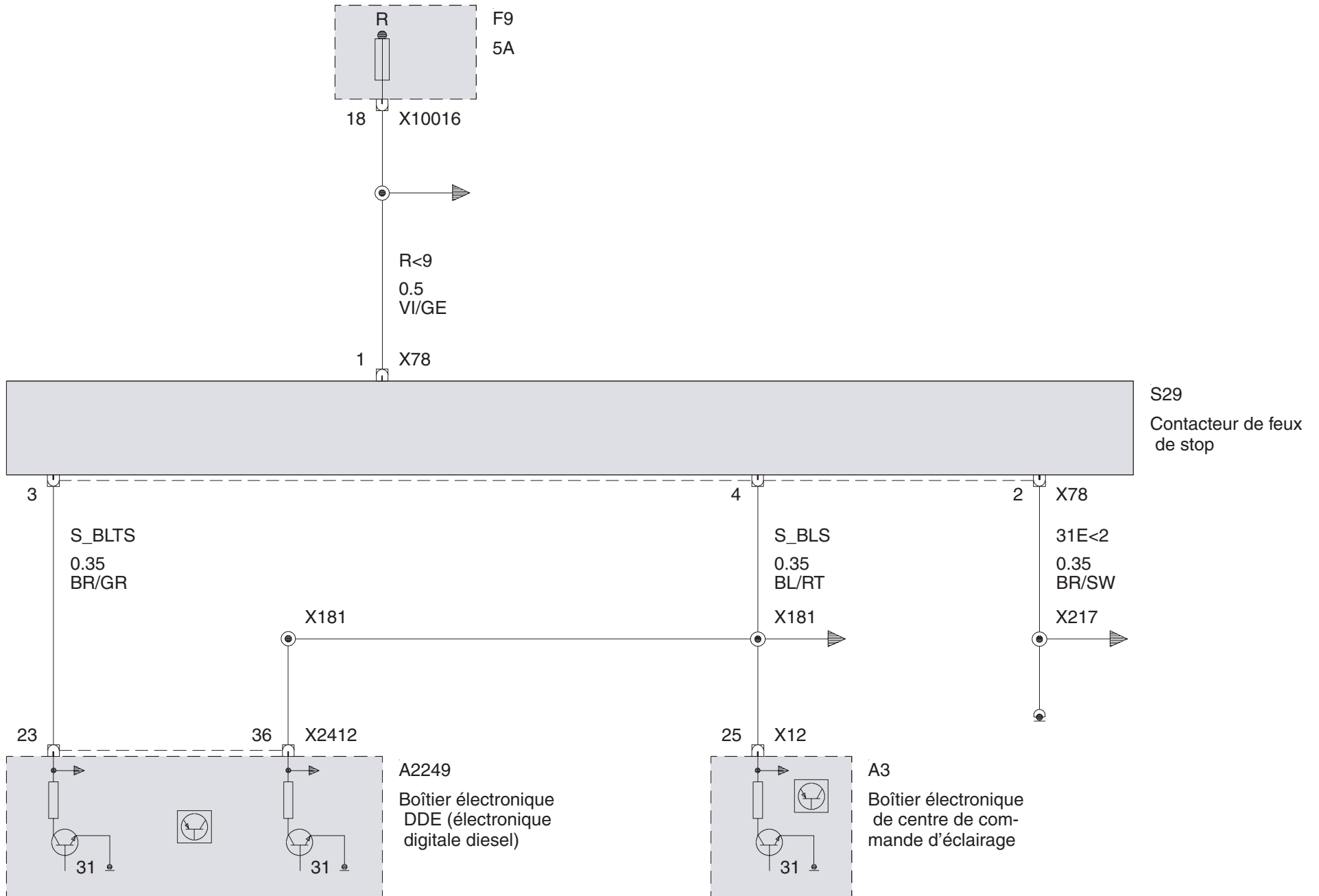

Contacteur de feux stop (DME Electronique moteur MS43 avec SMG Boîte de vitesses manuelle séquentielle)

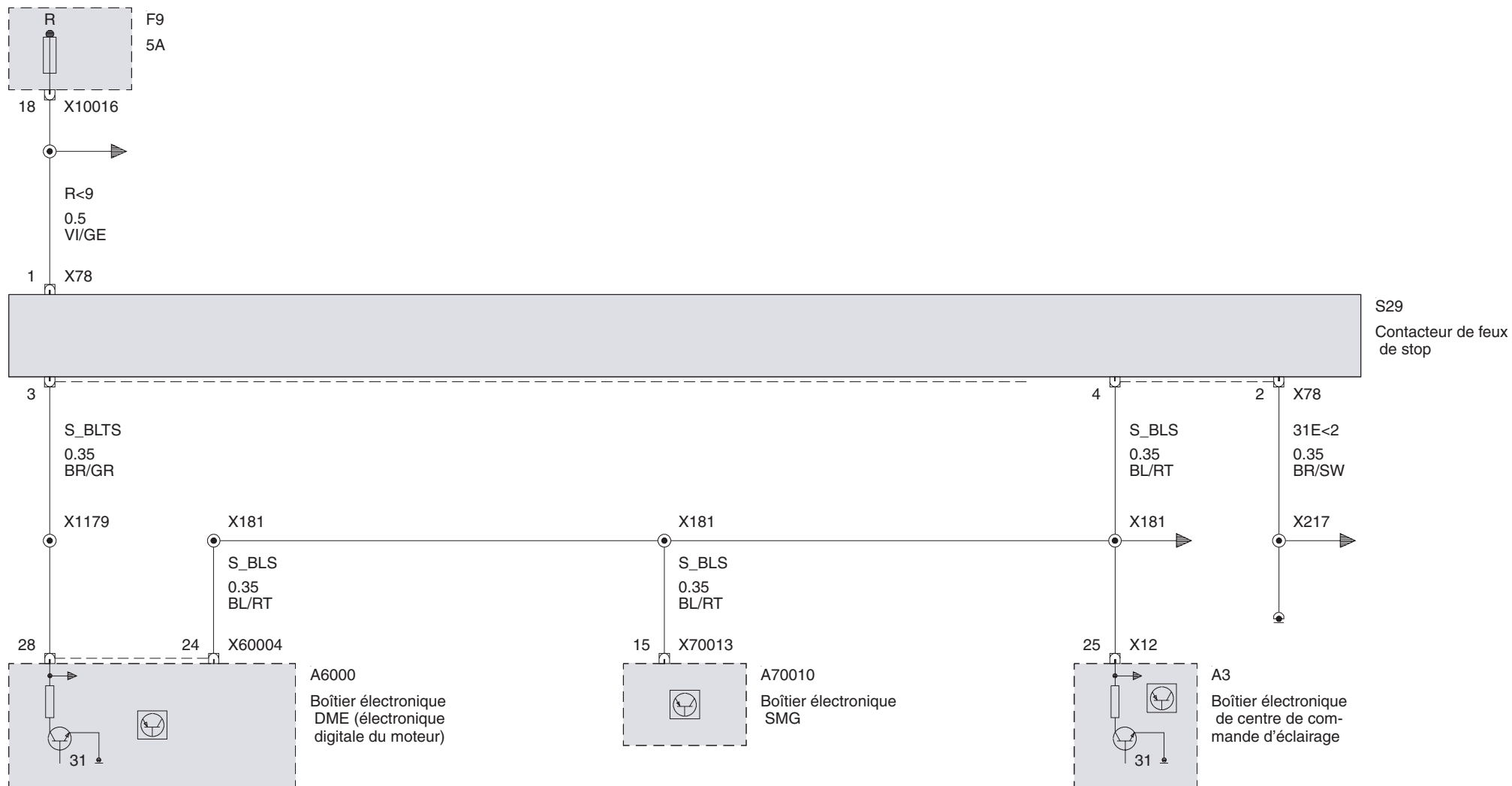

Feux stop (Berline)

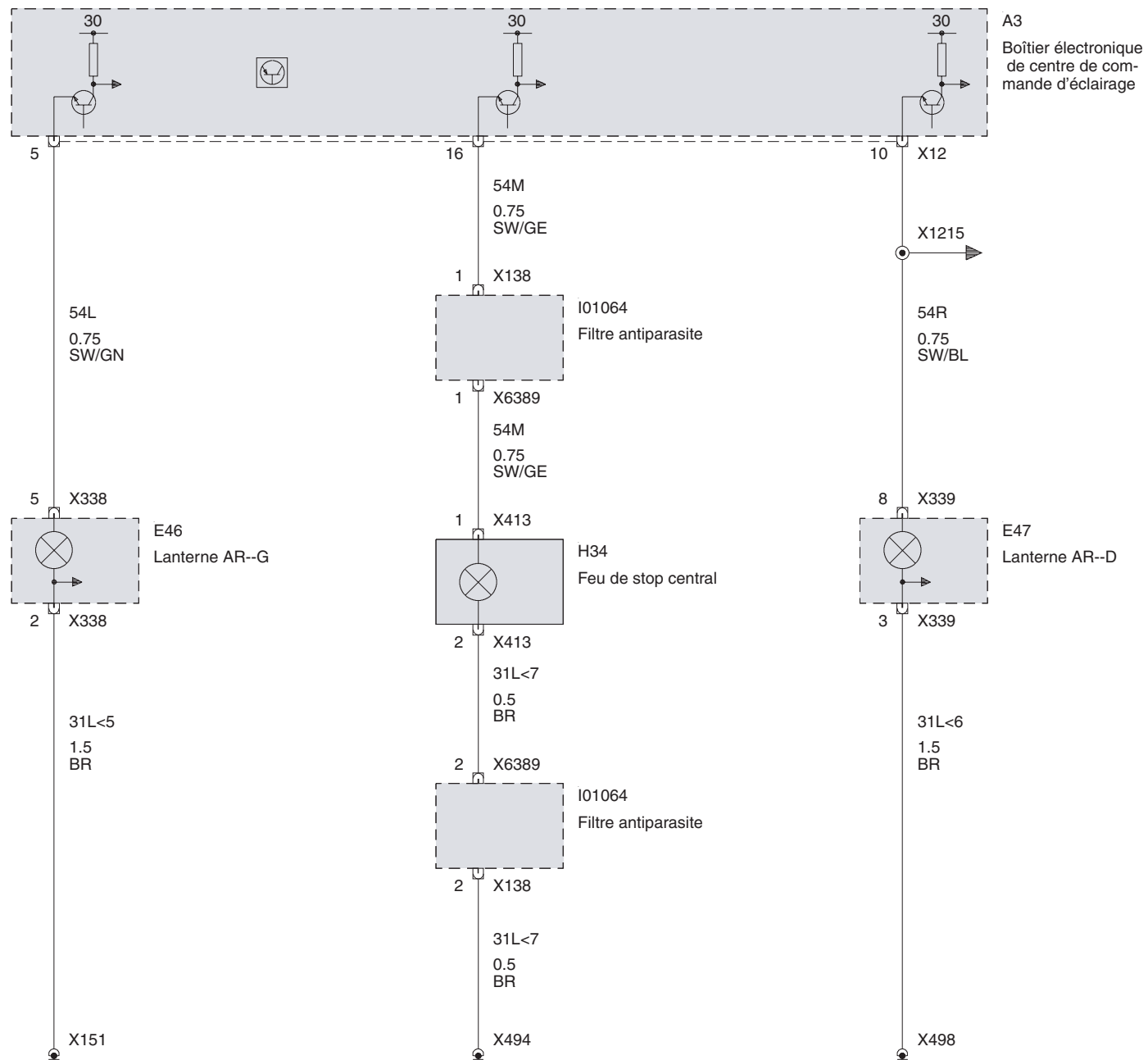

Feux stop (Coupé ou Cabriolet à partir de 2001\_09 jusque 2003\_03)

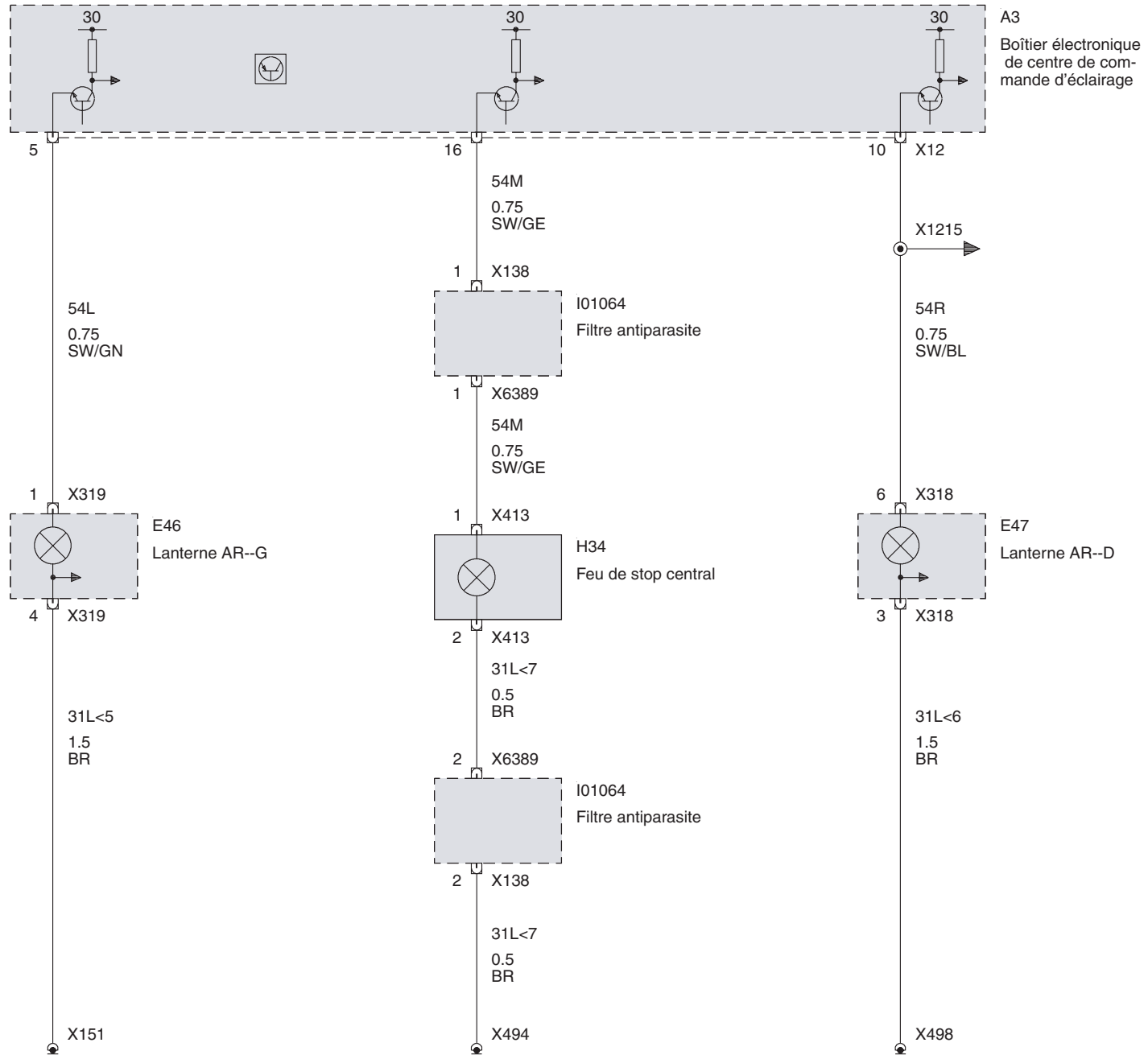



Feux stop (Coupé ou Cabriolet à partir de 2003\_03)

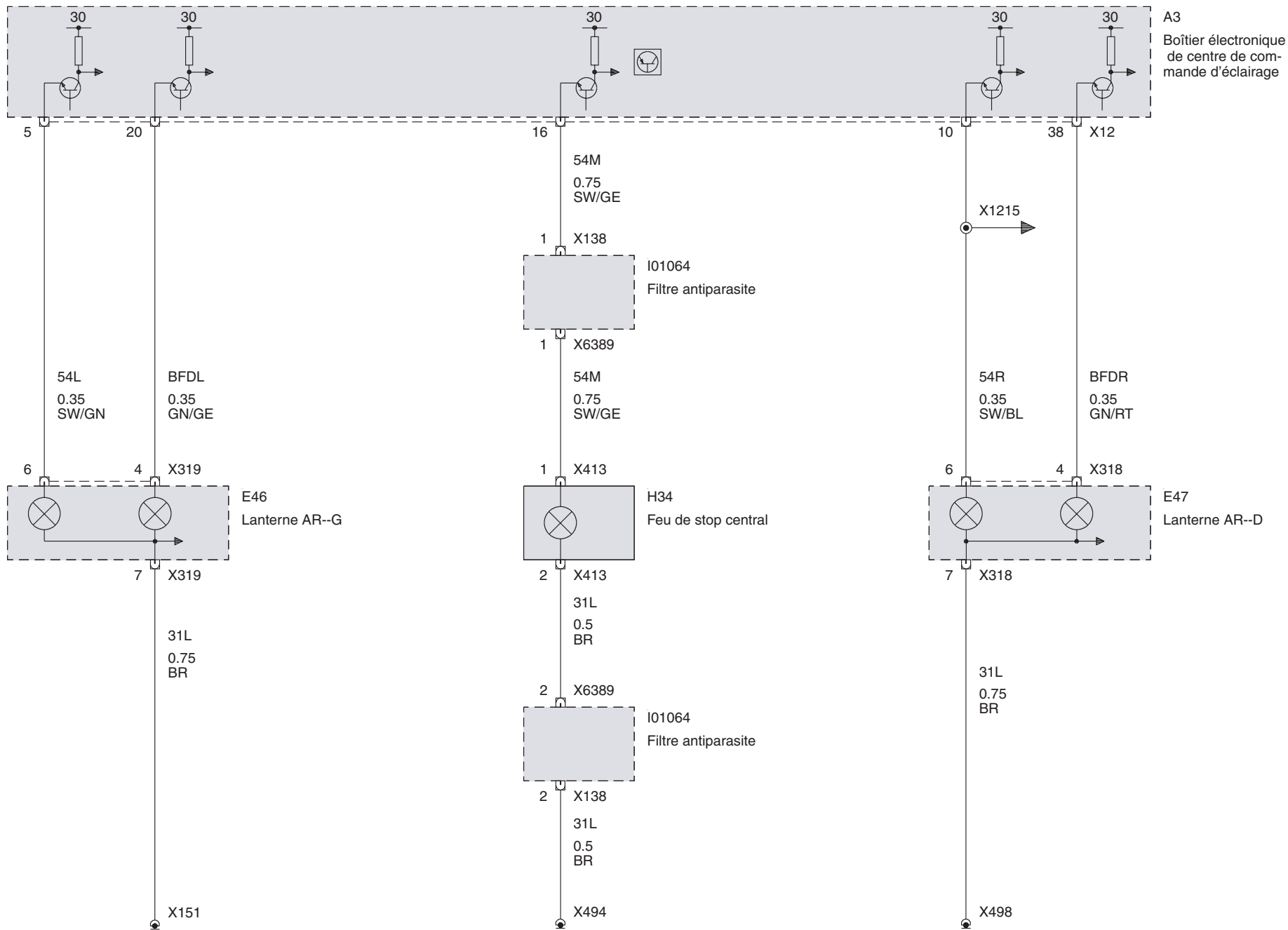

Feux stop (Touring)

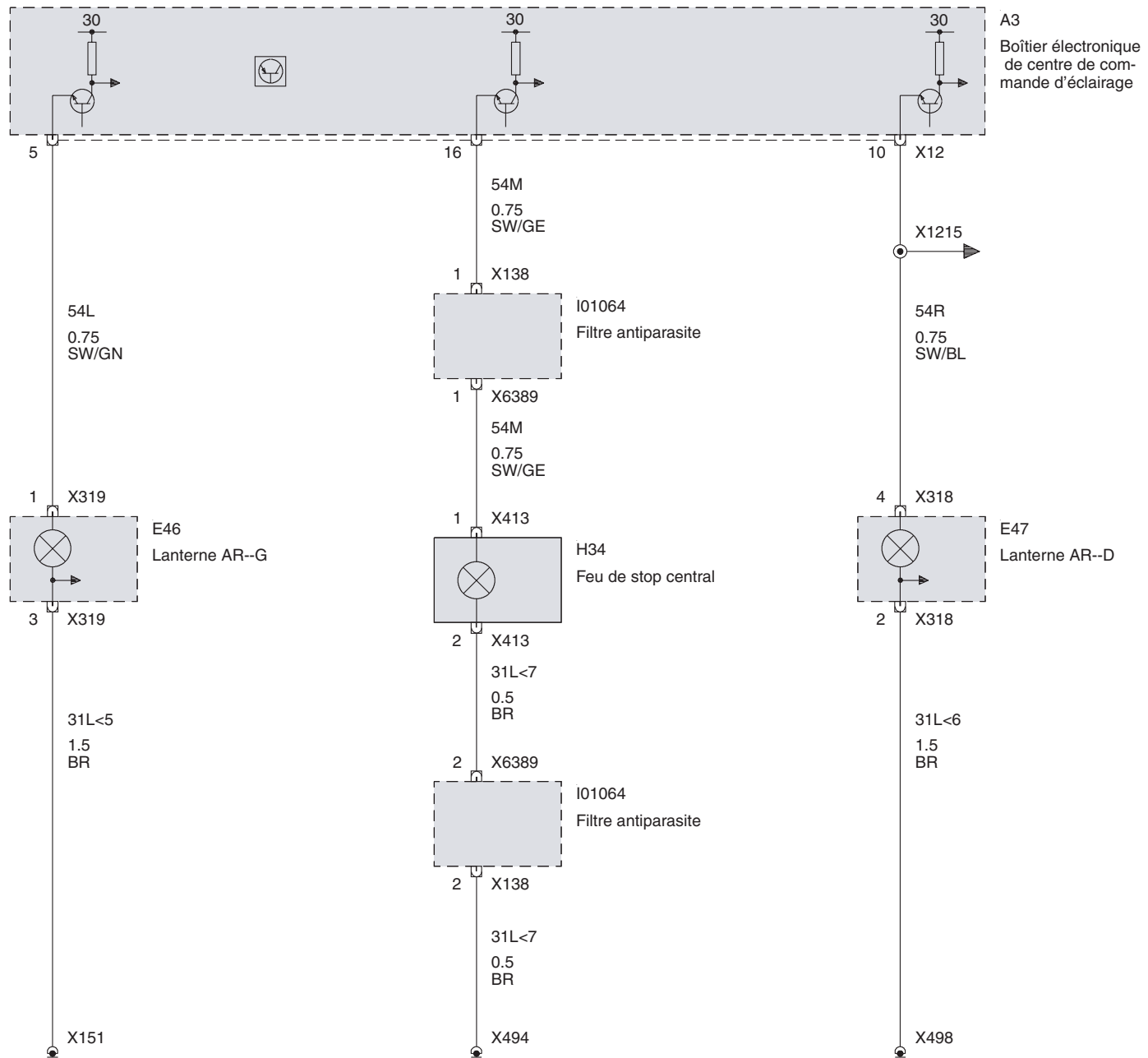

Feux stop (Compact)

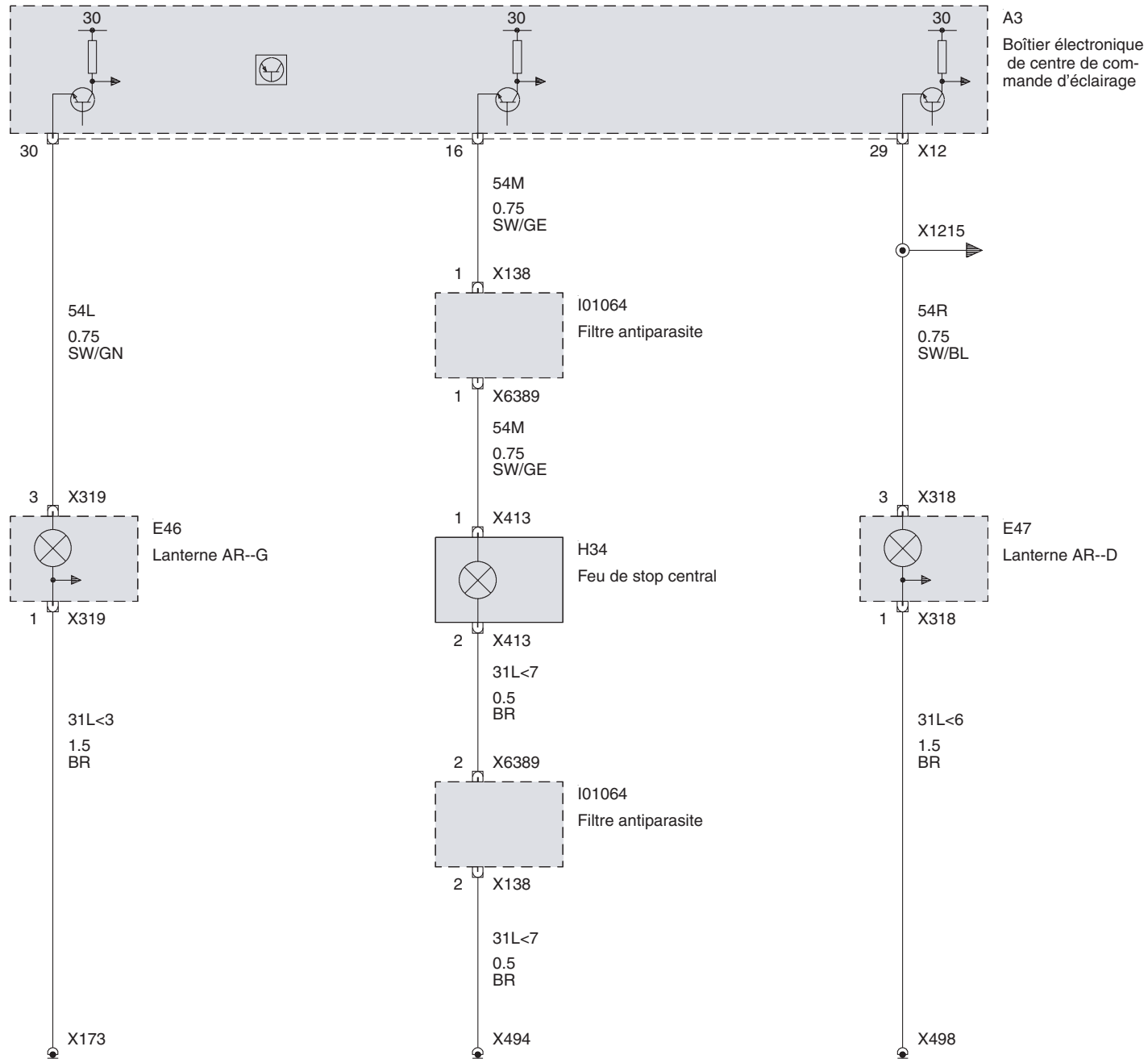

Clignotants, Feux de détresse  
Clignotants (Berline)

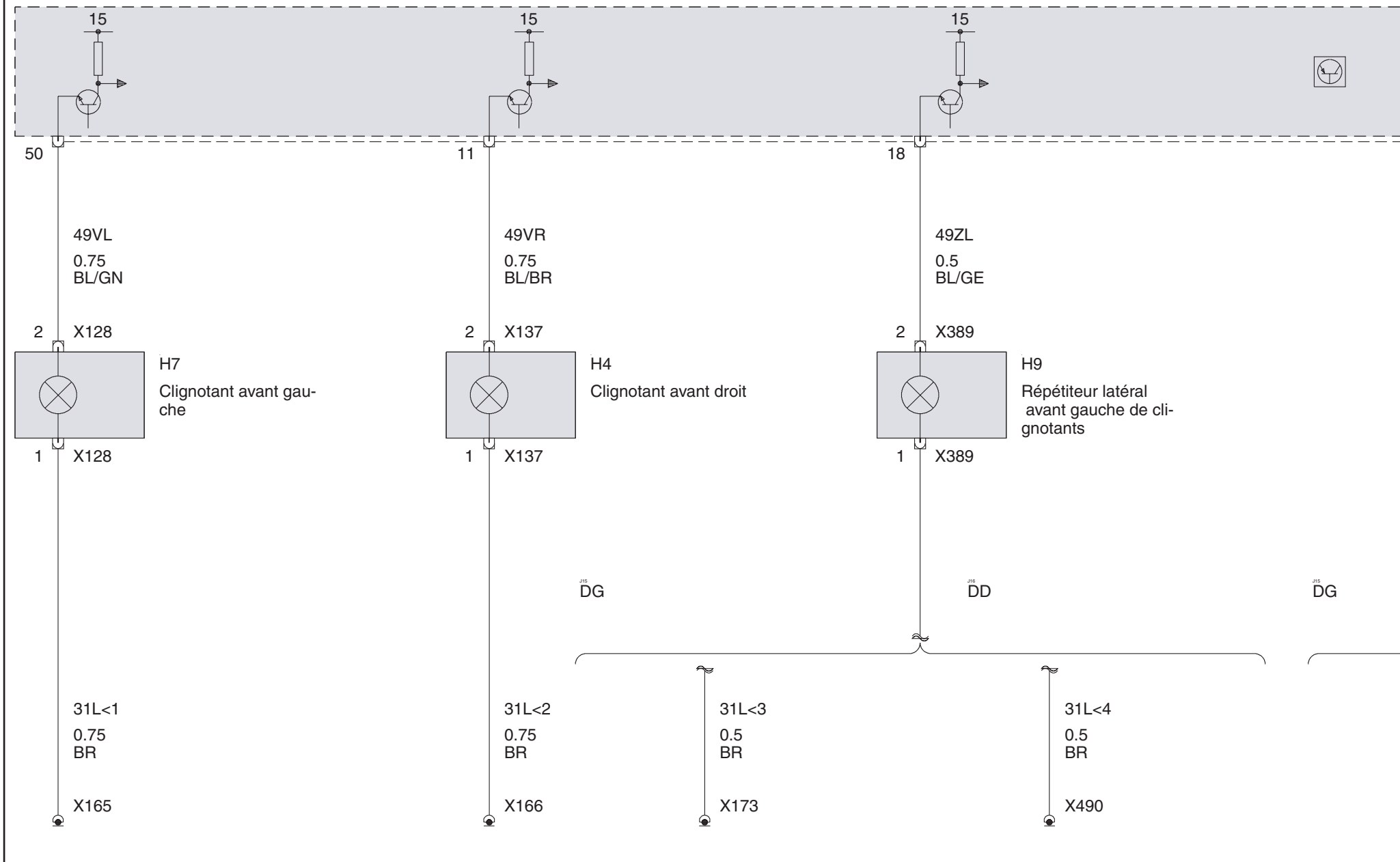

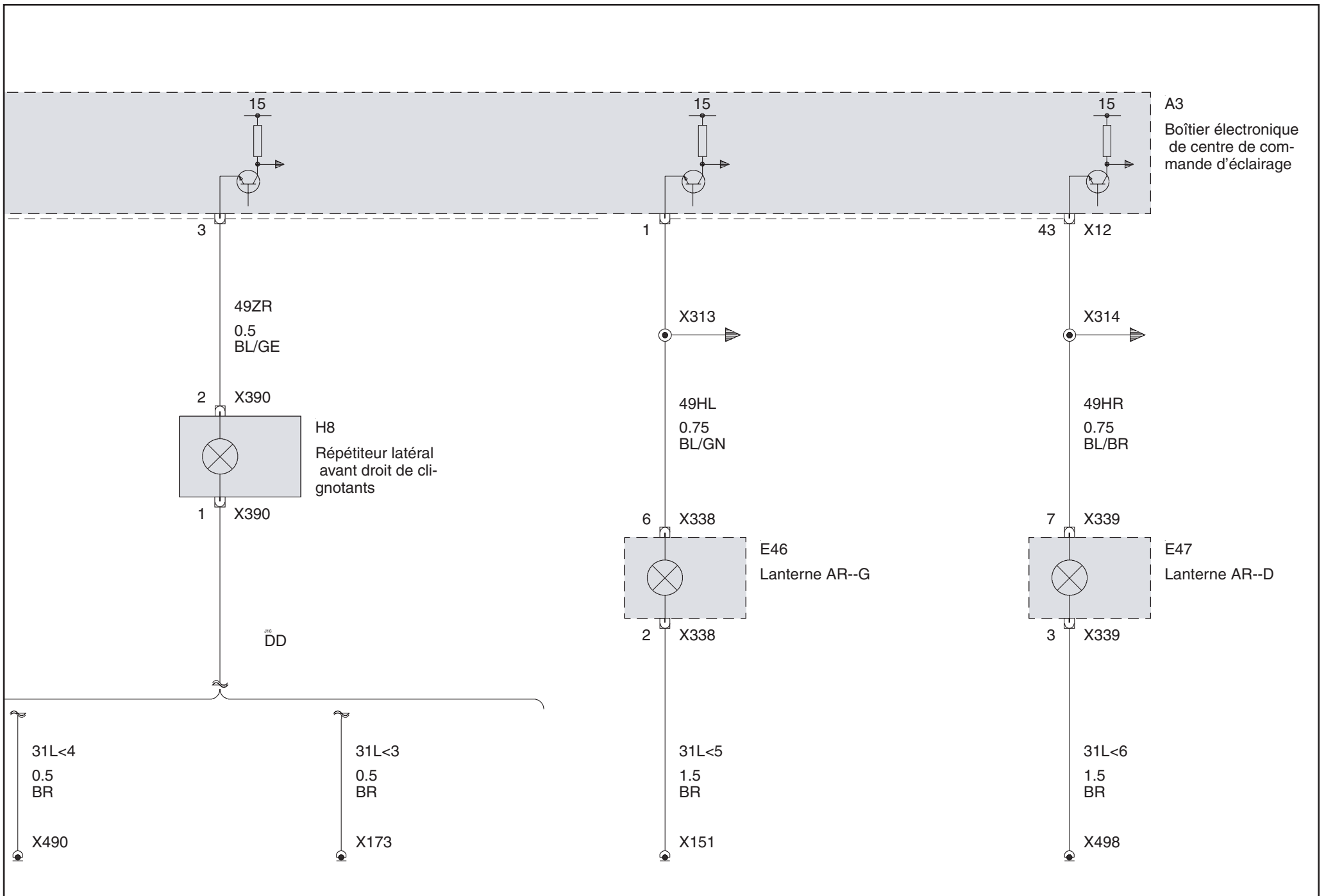

Clignotants (Coupé ou Cabriolet à partir de 2001\_09 jusque 2003\_03)

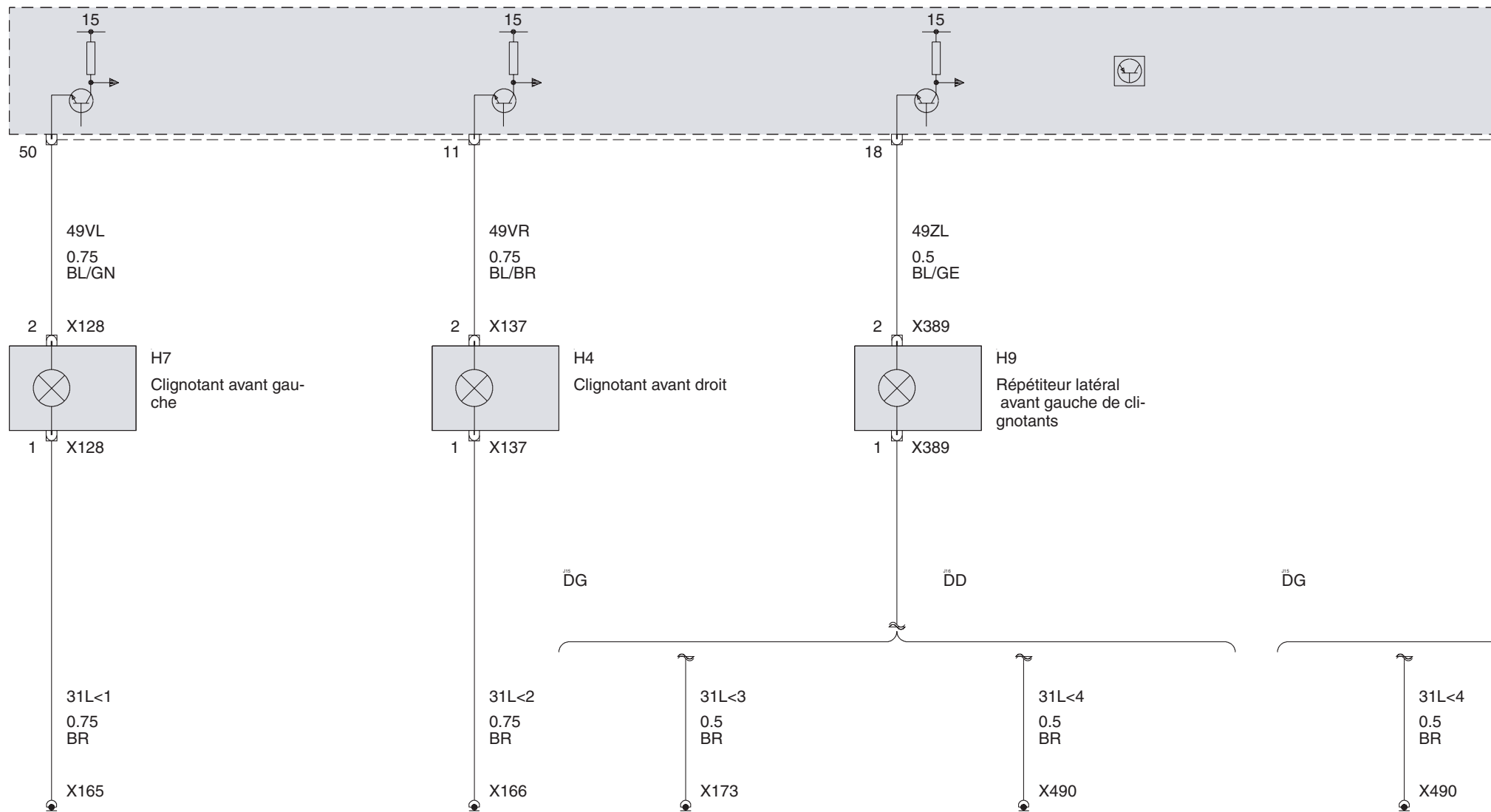

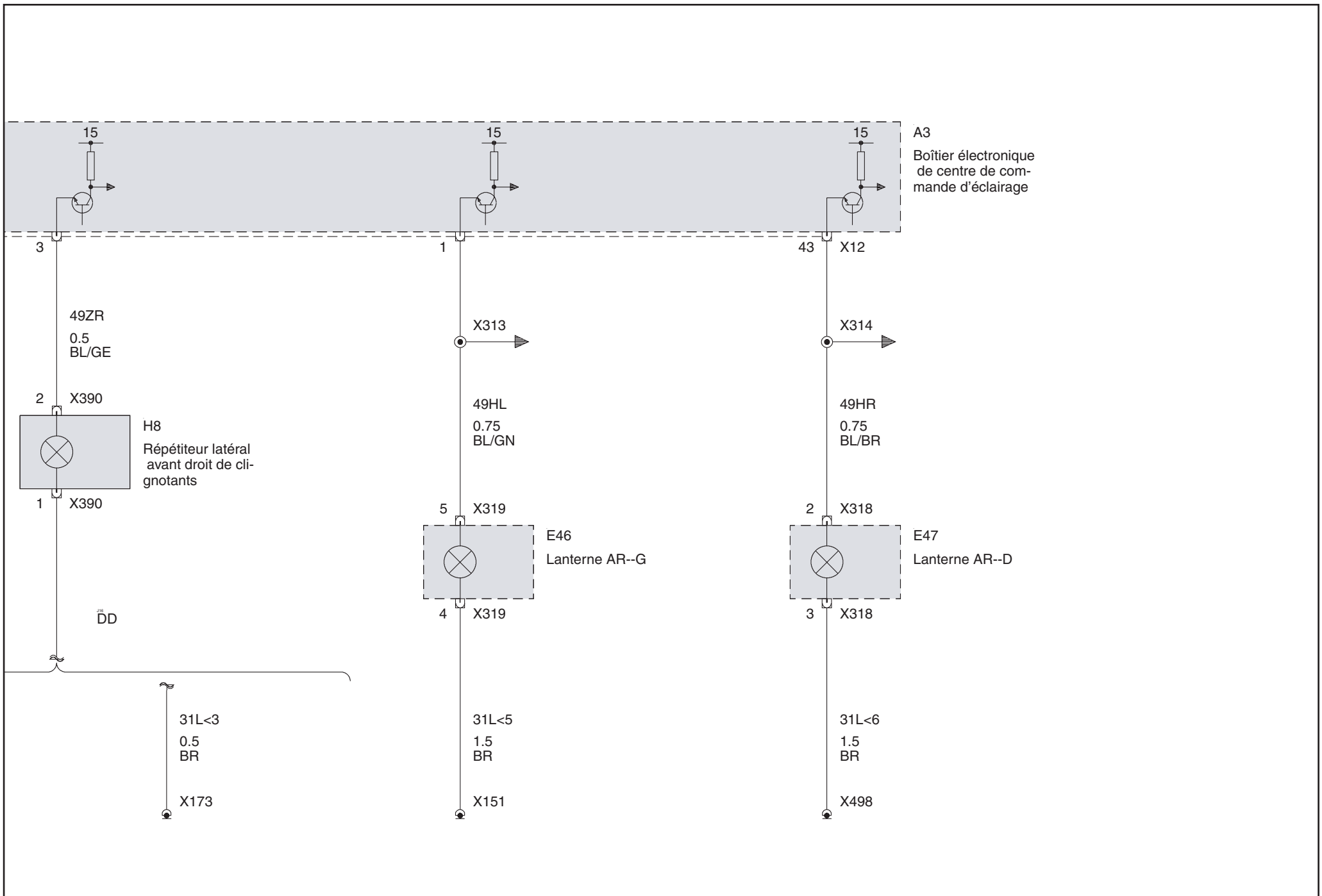

Clignotants (Touring)

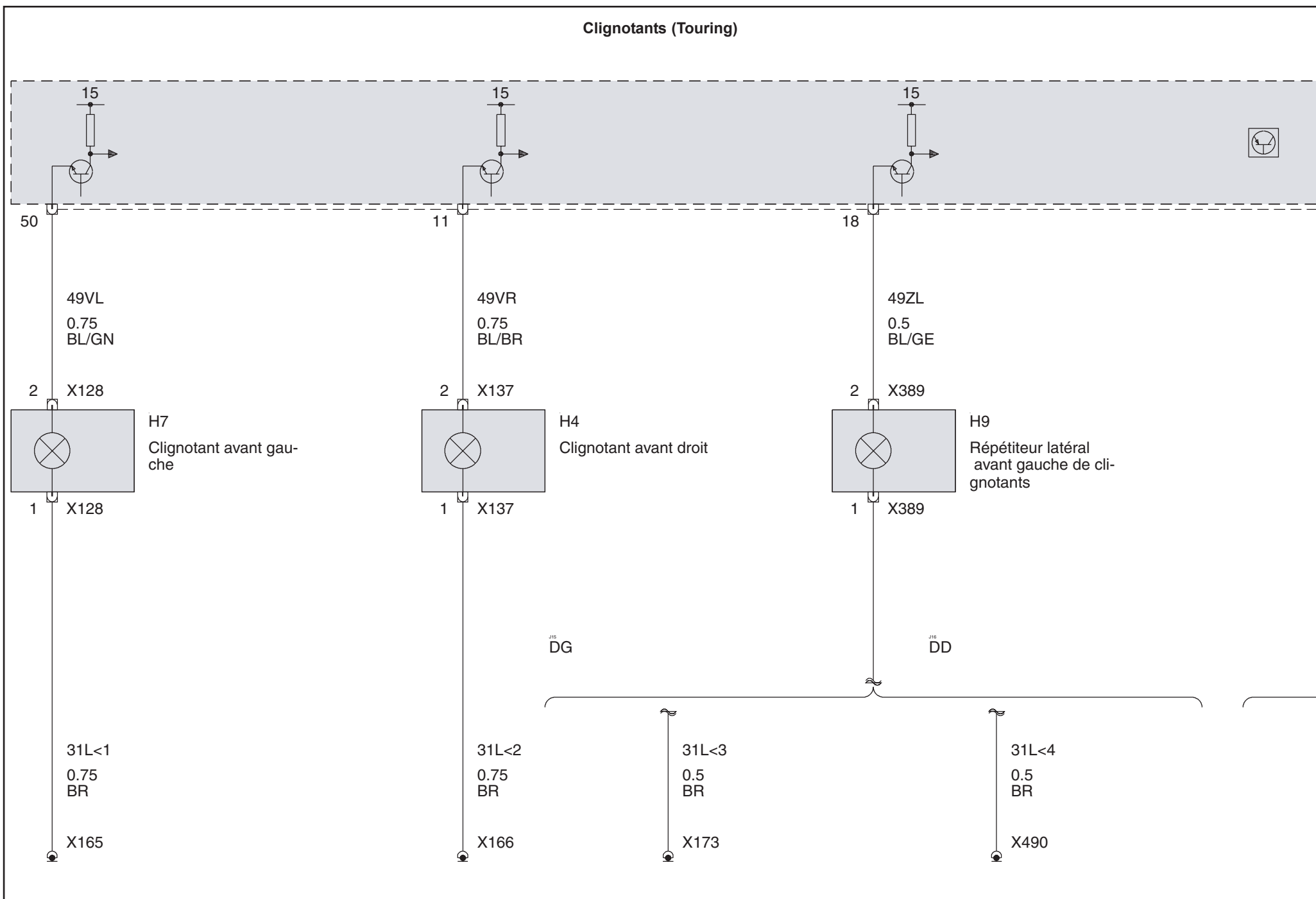



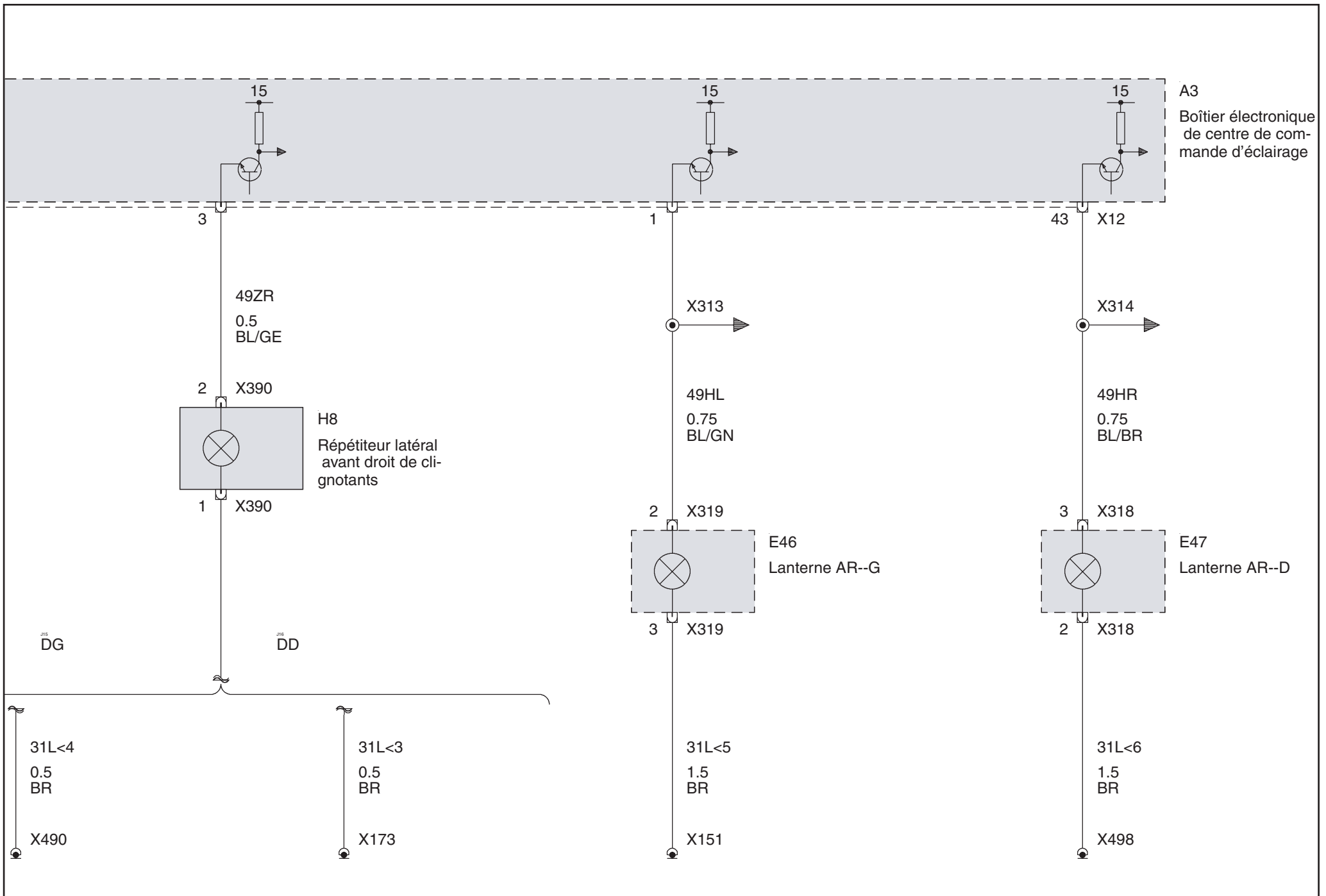

Clignotants (Compact)

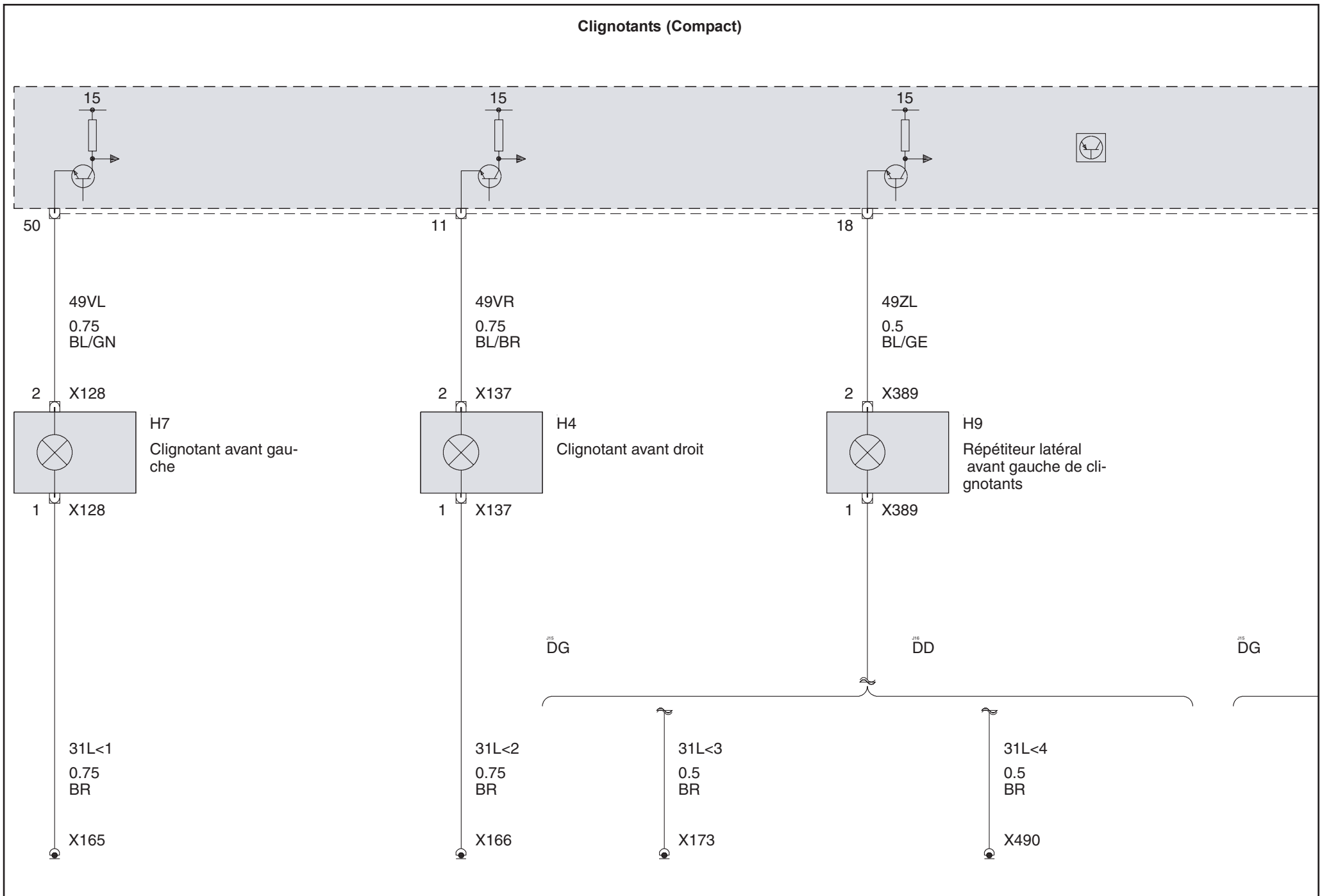

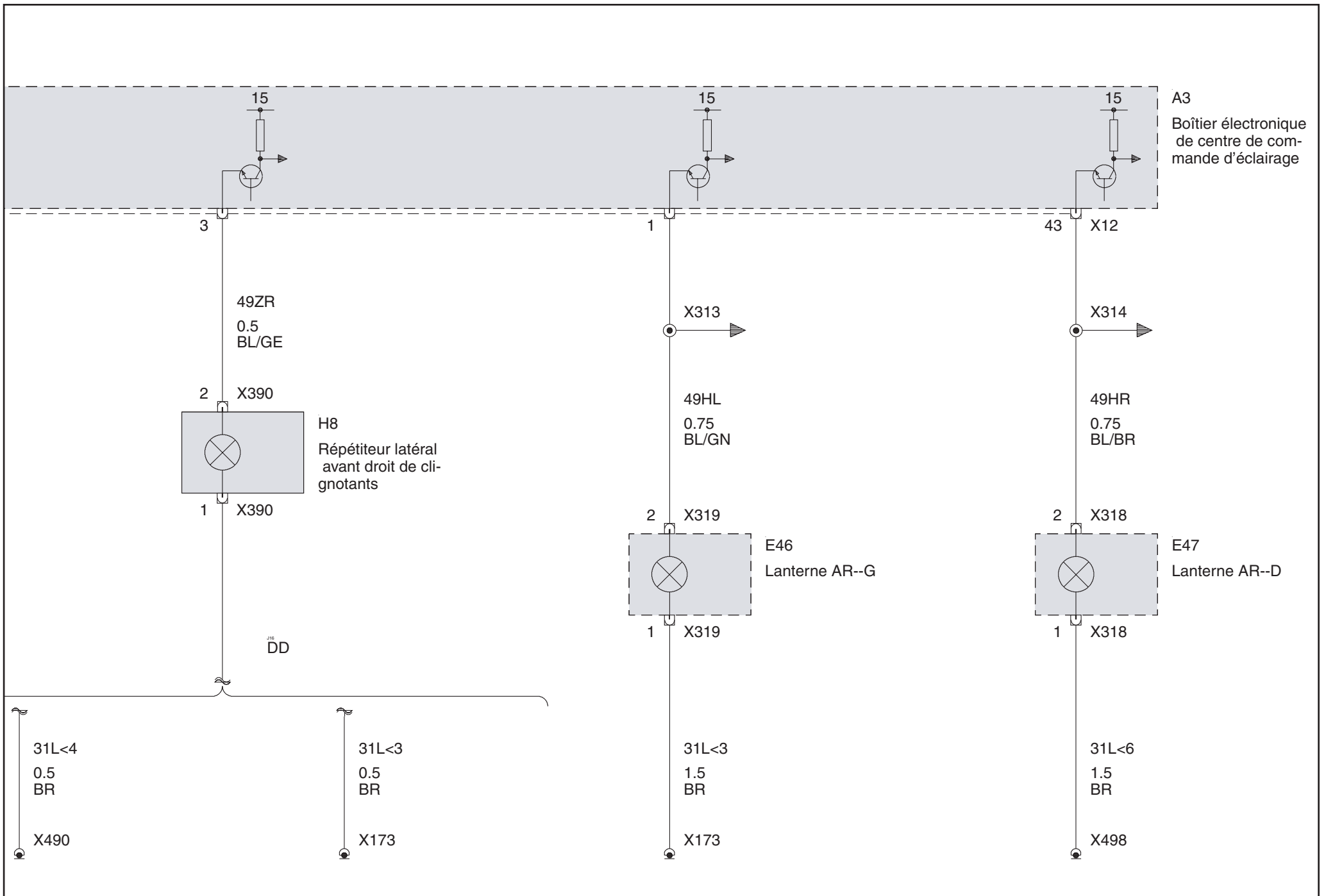

Clignotants (Coupé ou Cabriolet à partir de 2003\_03)

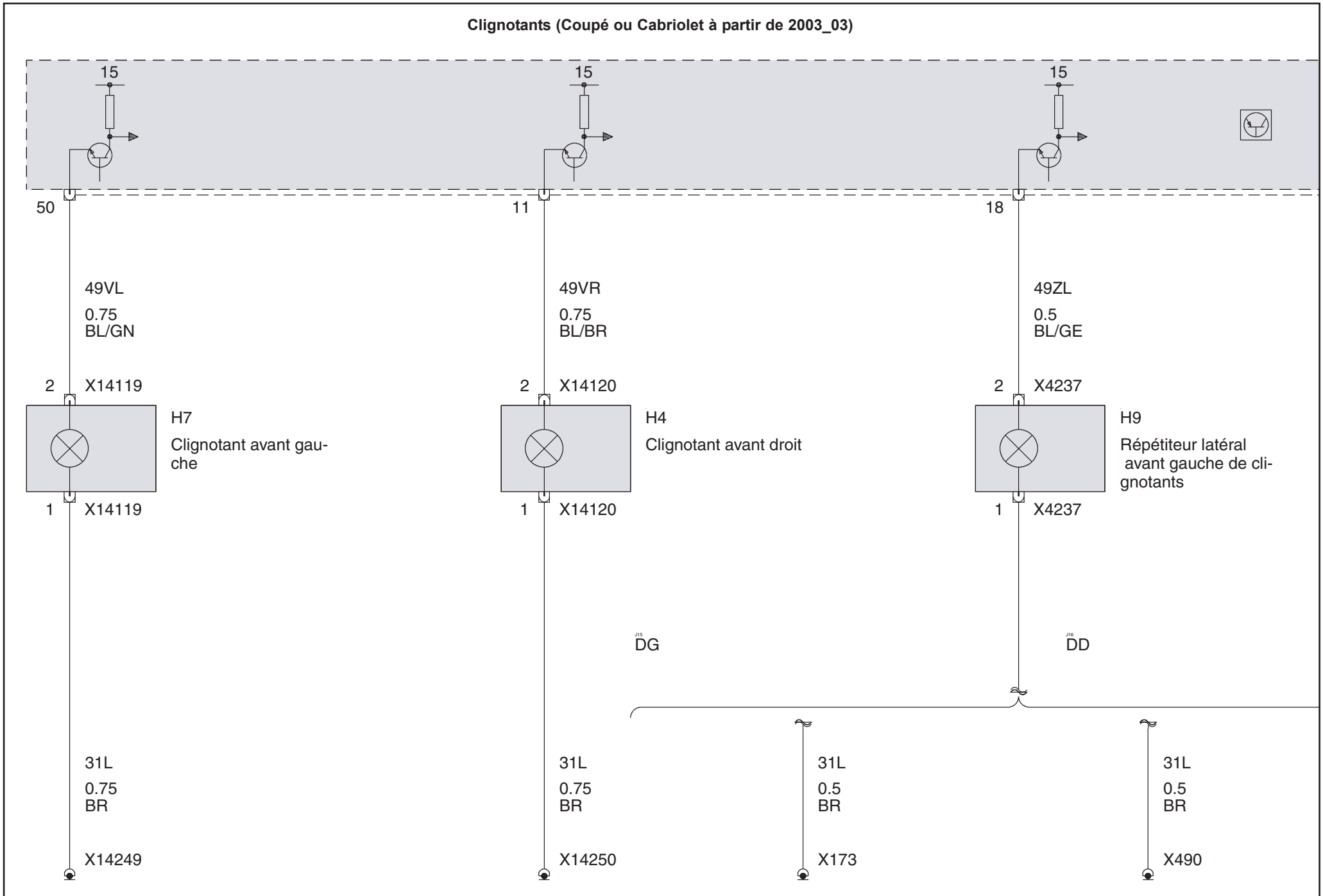

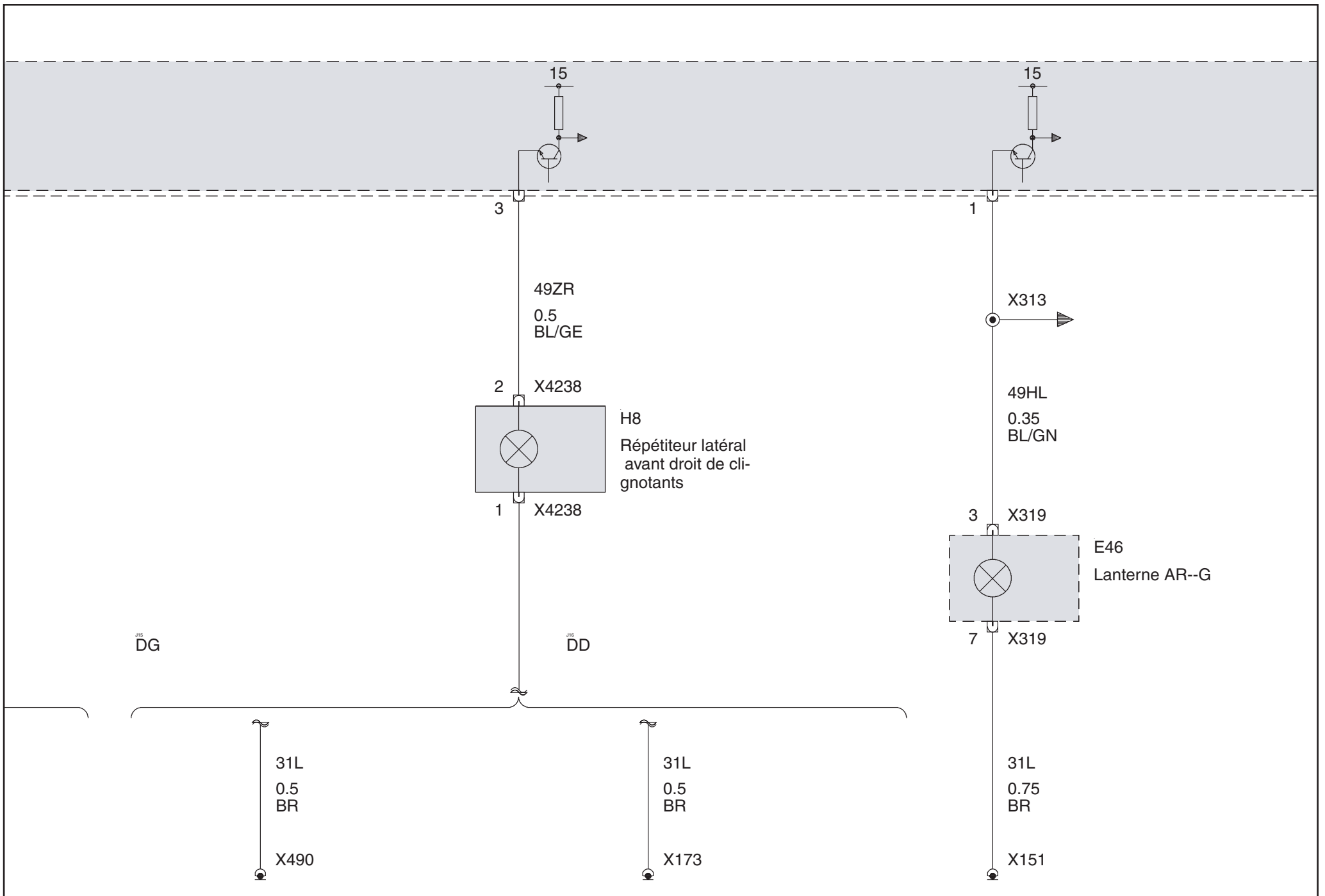



Touche de feux de détresse

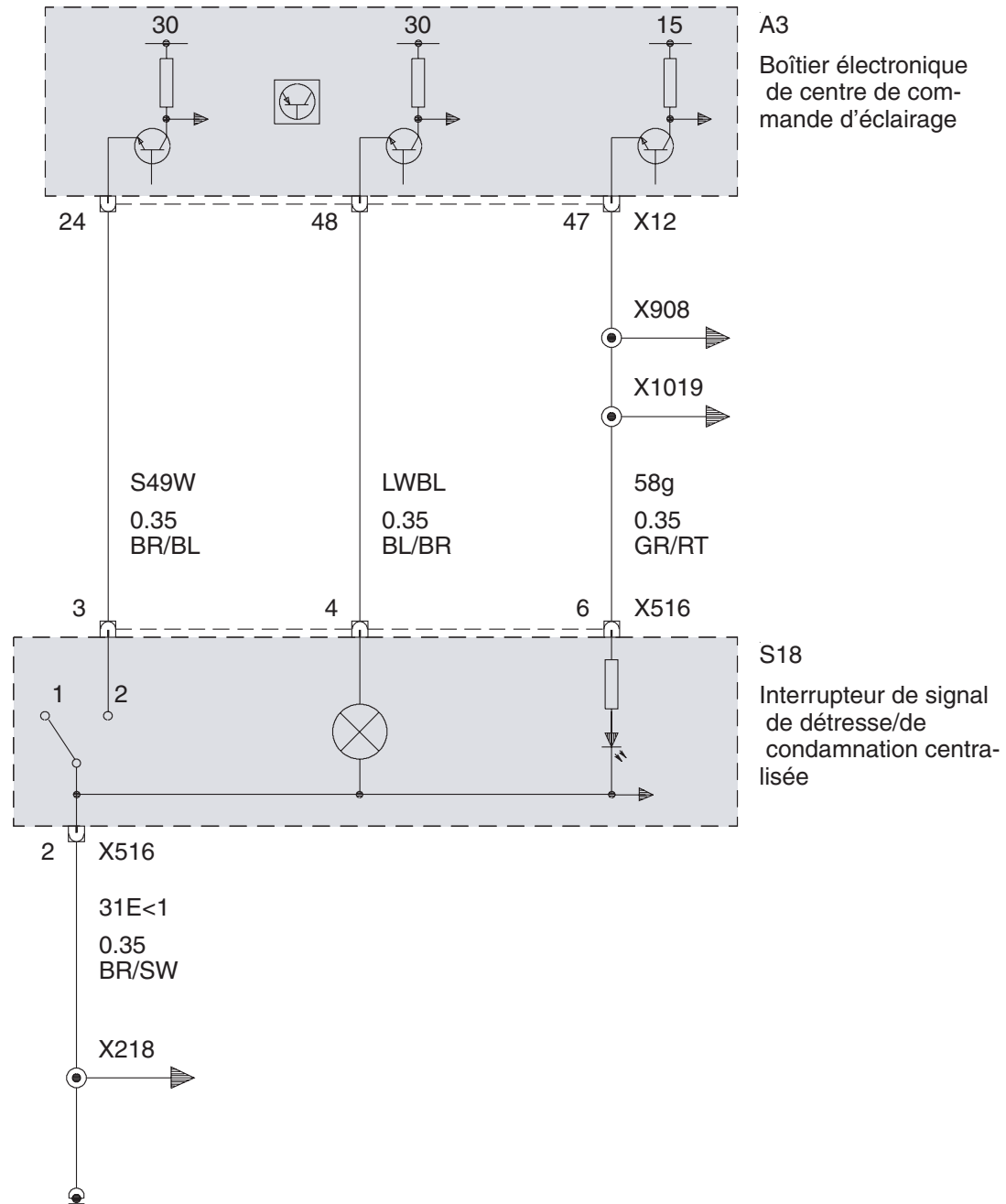

Feux antibrouillard

Projecteurs antibrouillard/feux arrière de brouillard (Berline)

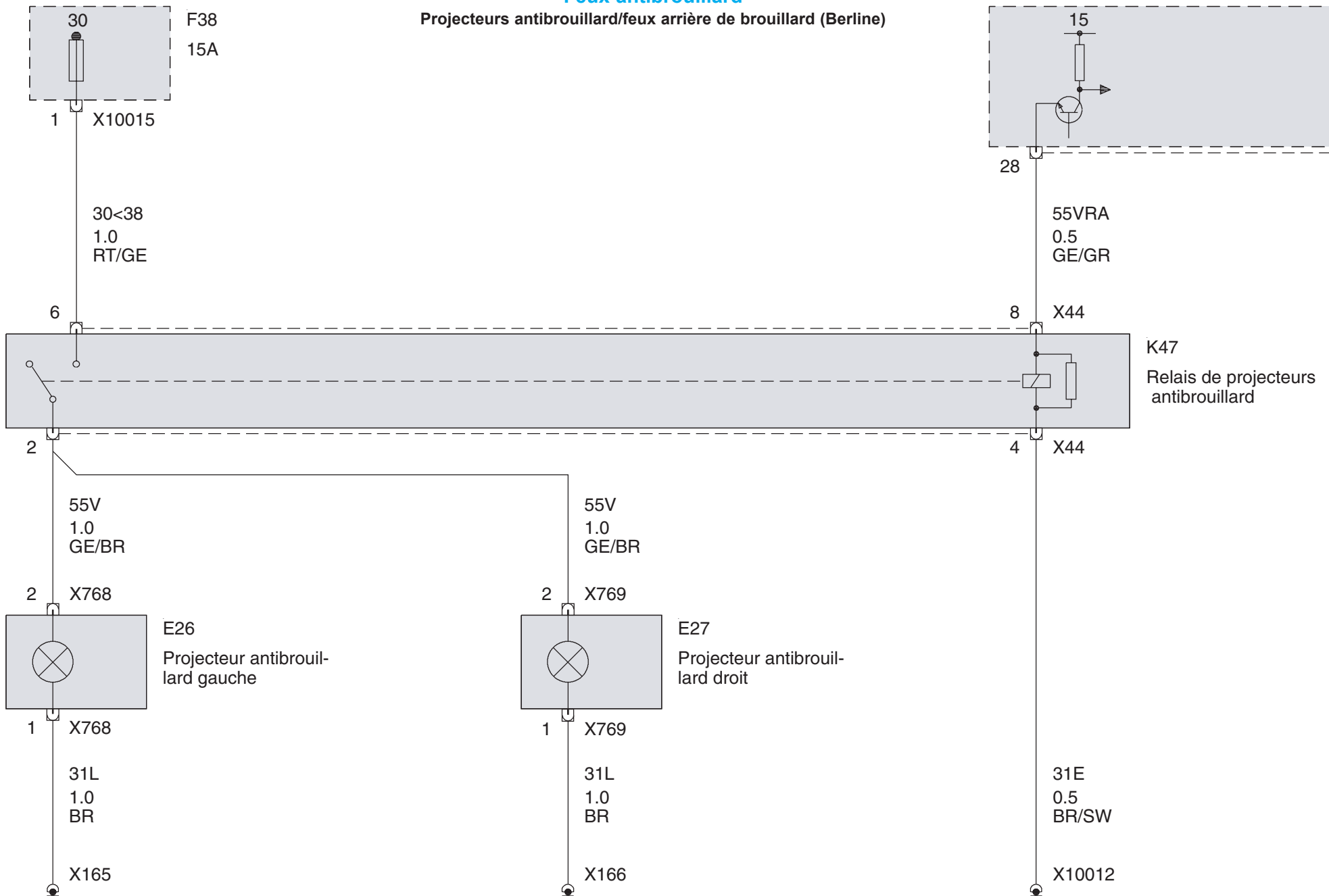



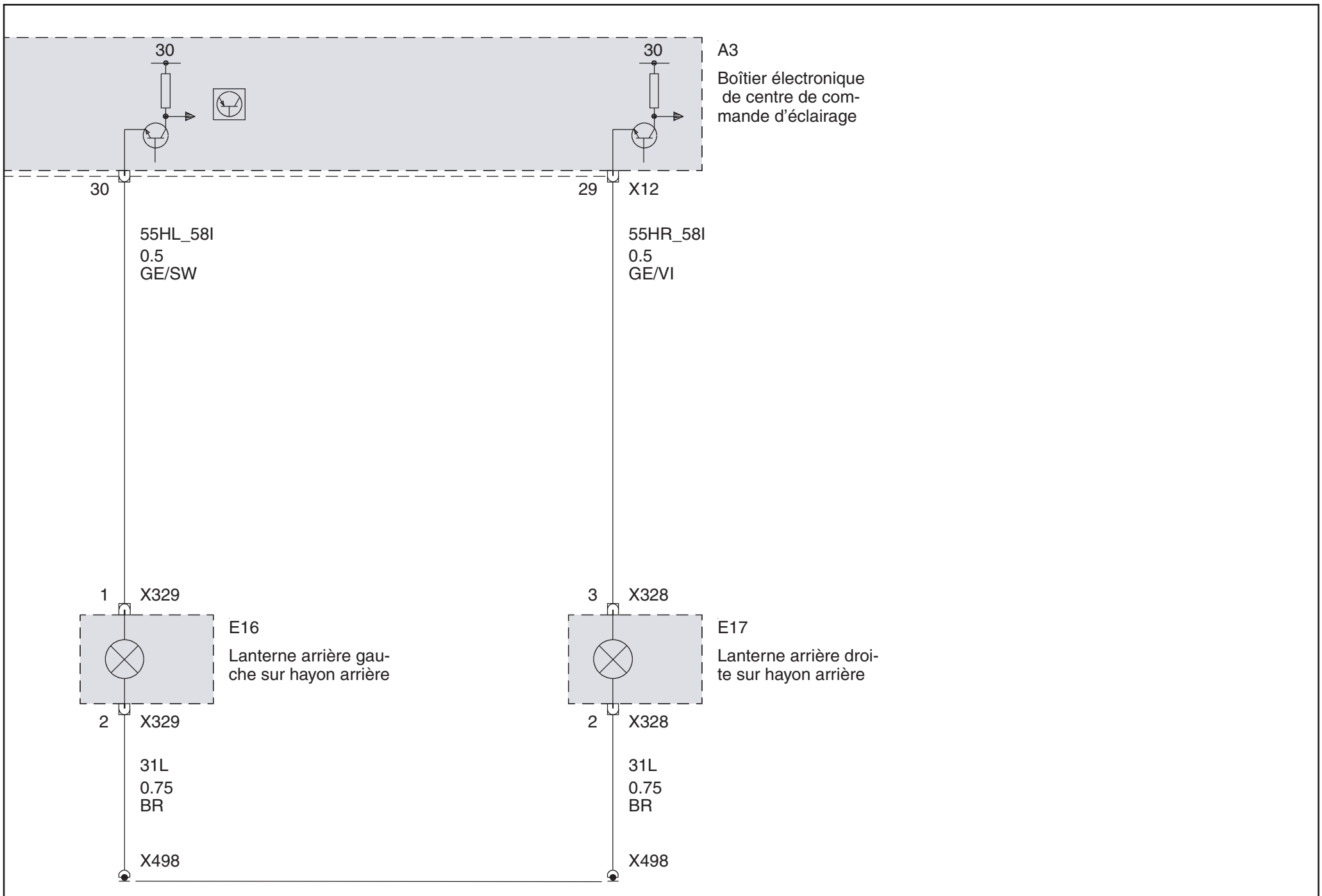

A3  
Boîtier électronique  
de centre de com-  
mande d'éclairage

E16  
Lanterne arrière gau-  
che sur hayon arrière

E17  
Lanterne arrière droi-  
te sur hayon arrière

Projecteurs antibrouillard/feux arrière de brouillard ( Touring ou Coupé ou Cabriolet à partir de 2001\_09 jusque 2003\_03)

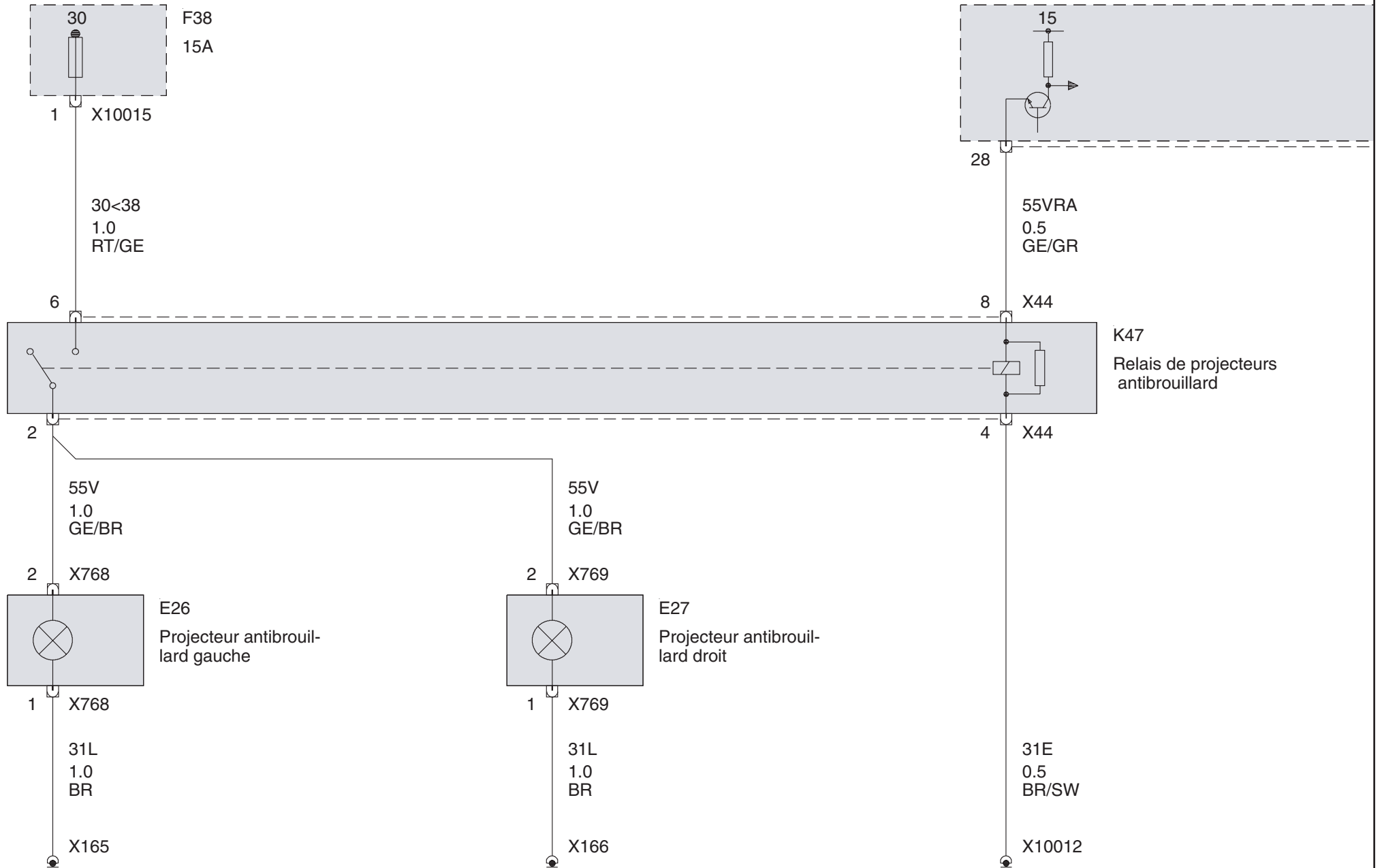

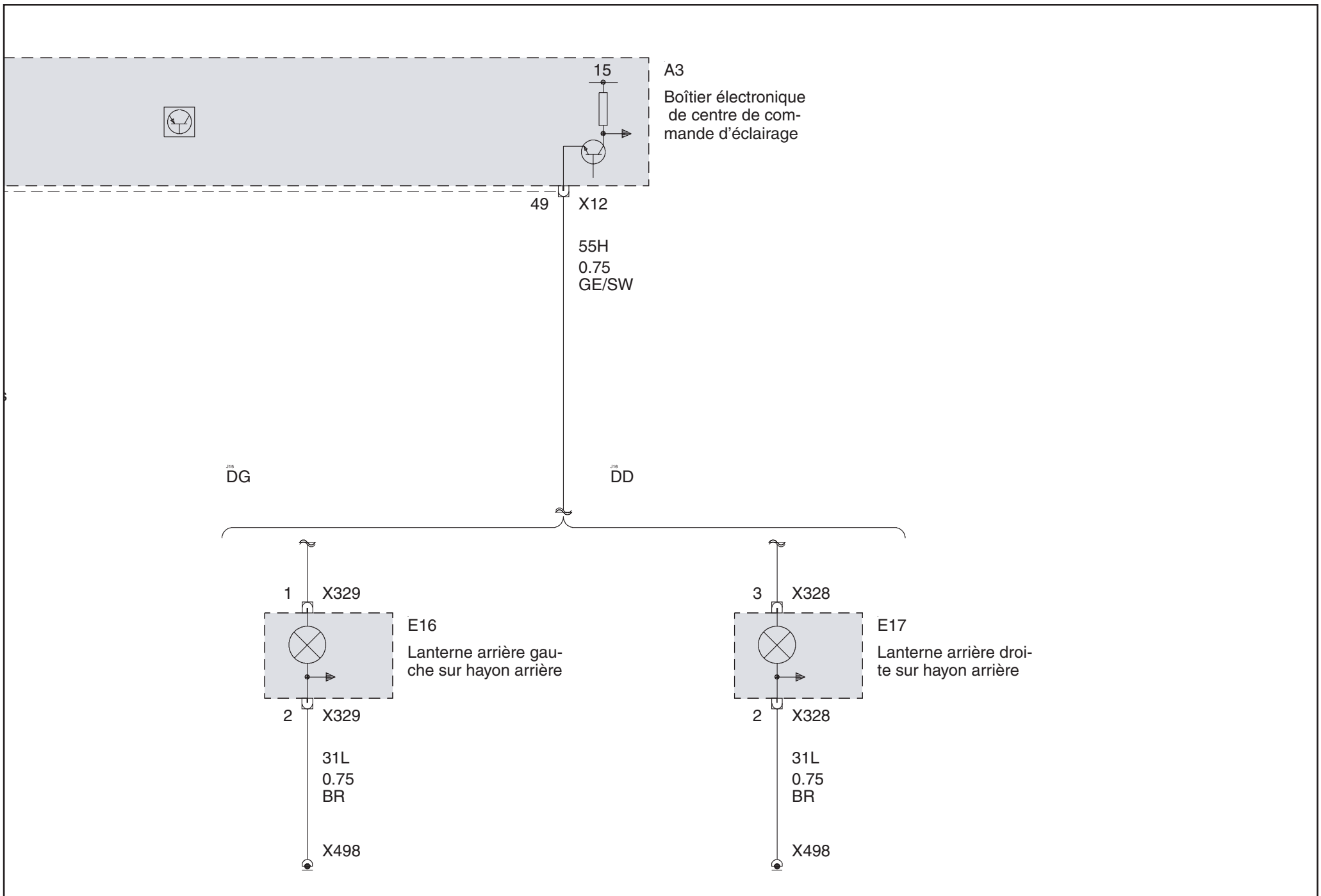

Projecteurs antibrouillard/feux arrière de brouillard (Touring à partir de 2003\_03)

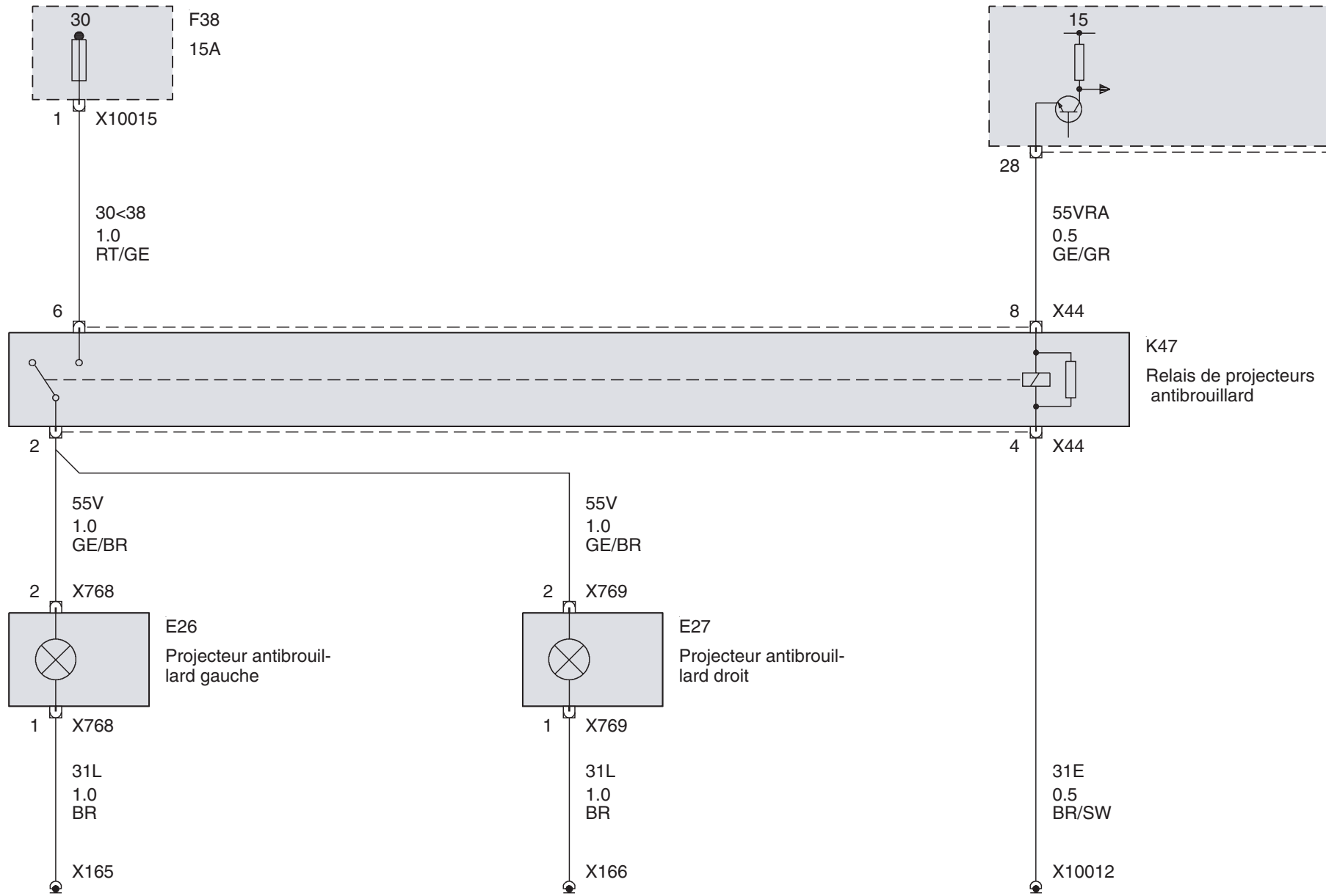

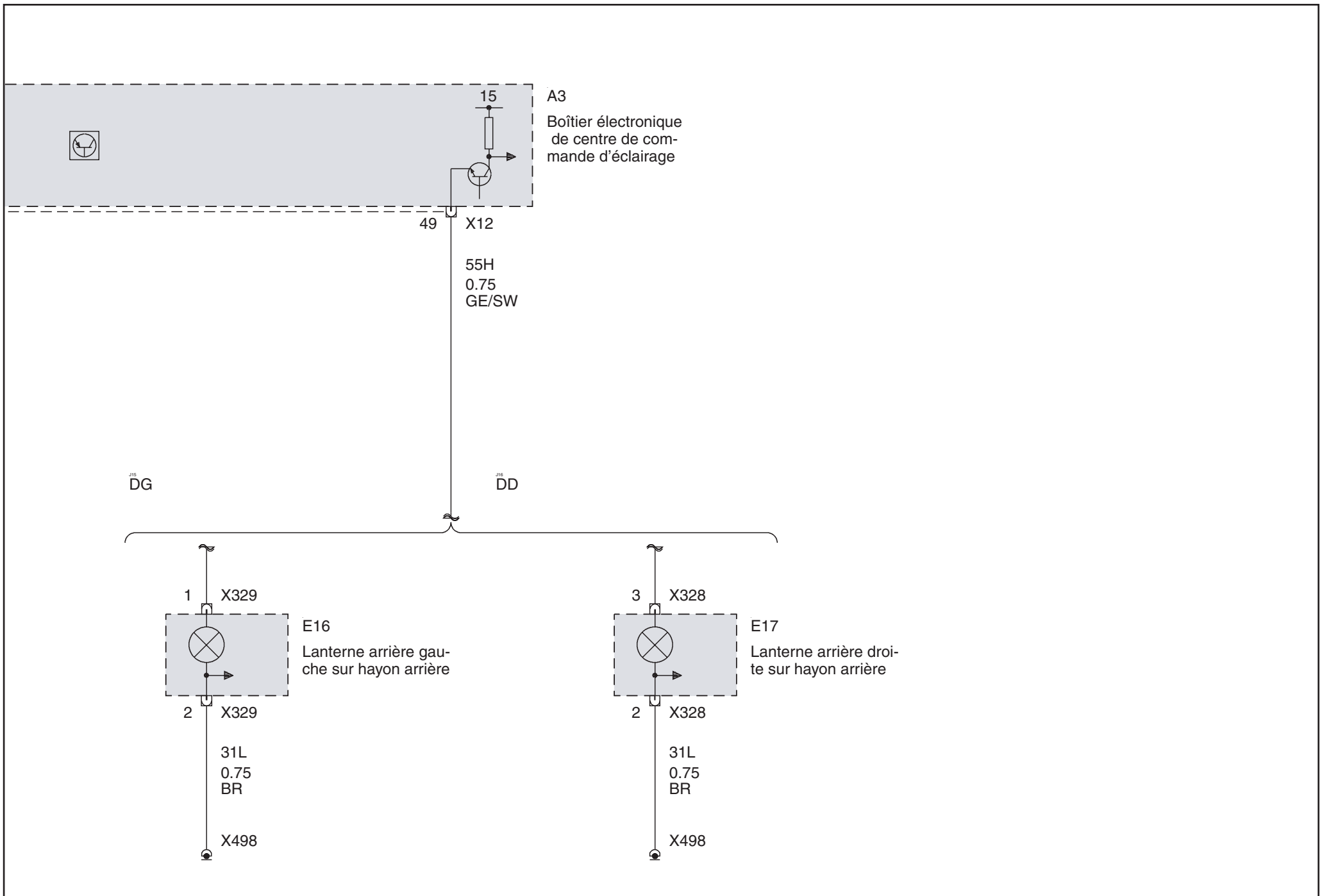

Projecteurs antibrouillard/feux arrière de brouillard (Coupé ou Cabriolet à partir de 2003\_03)

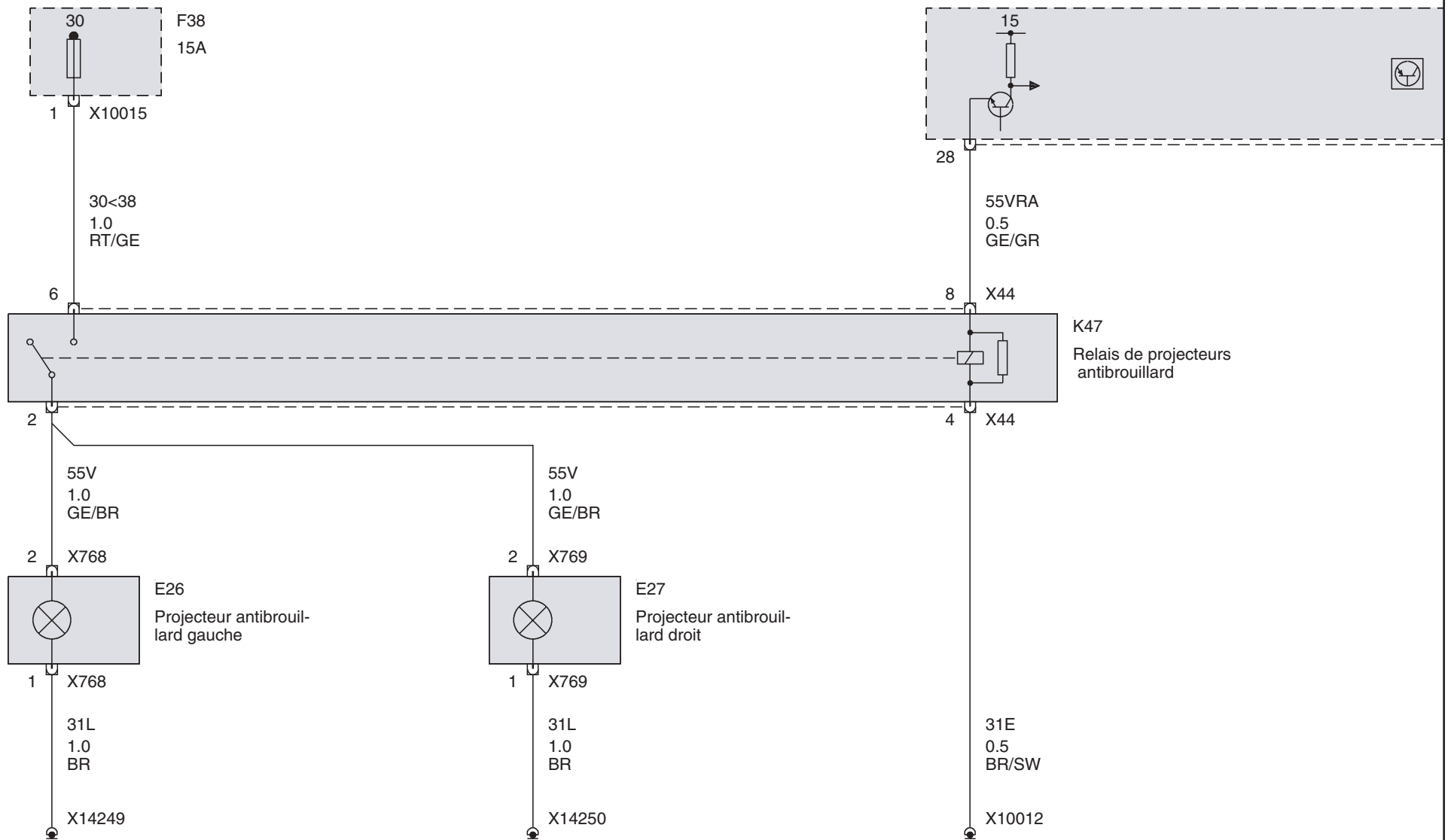

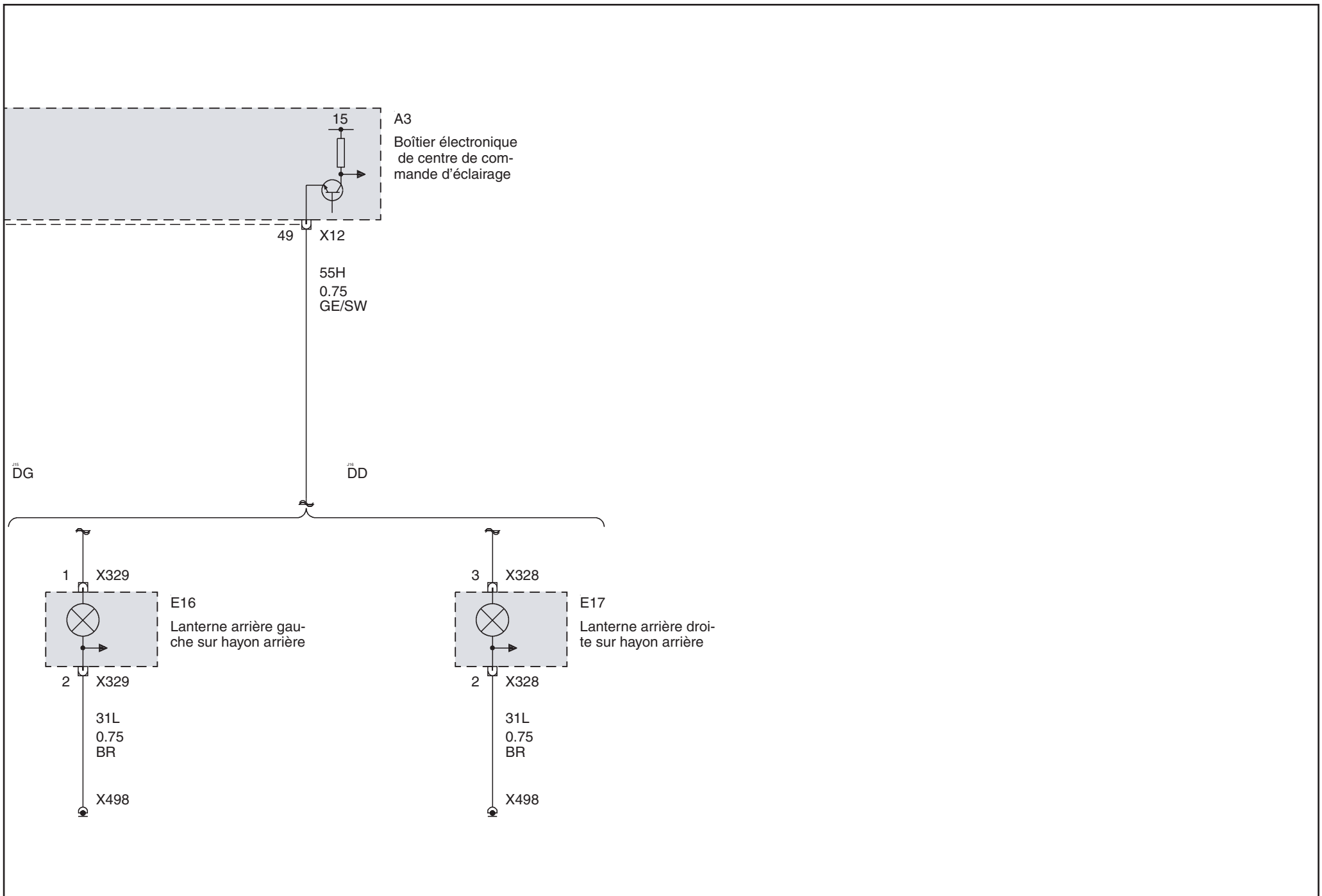

Projecteurs antibrouillard/feux arrière de brouillard (Compact)

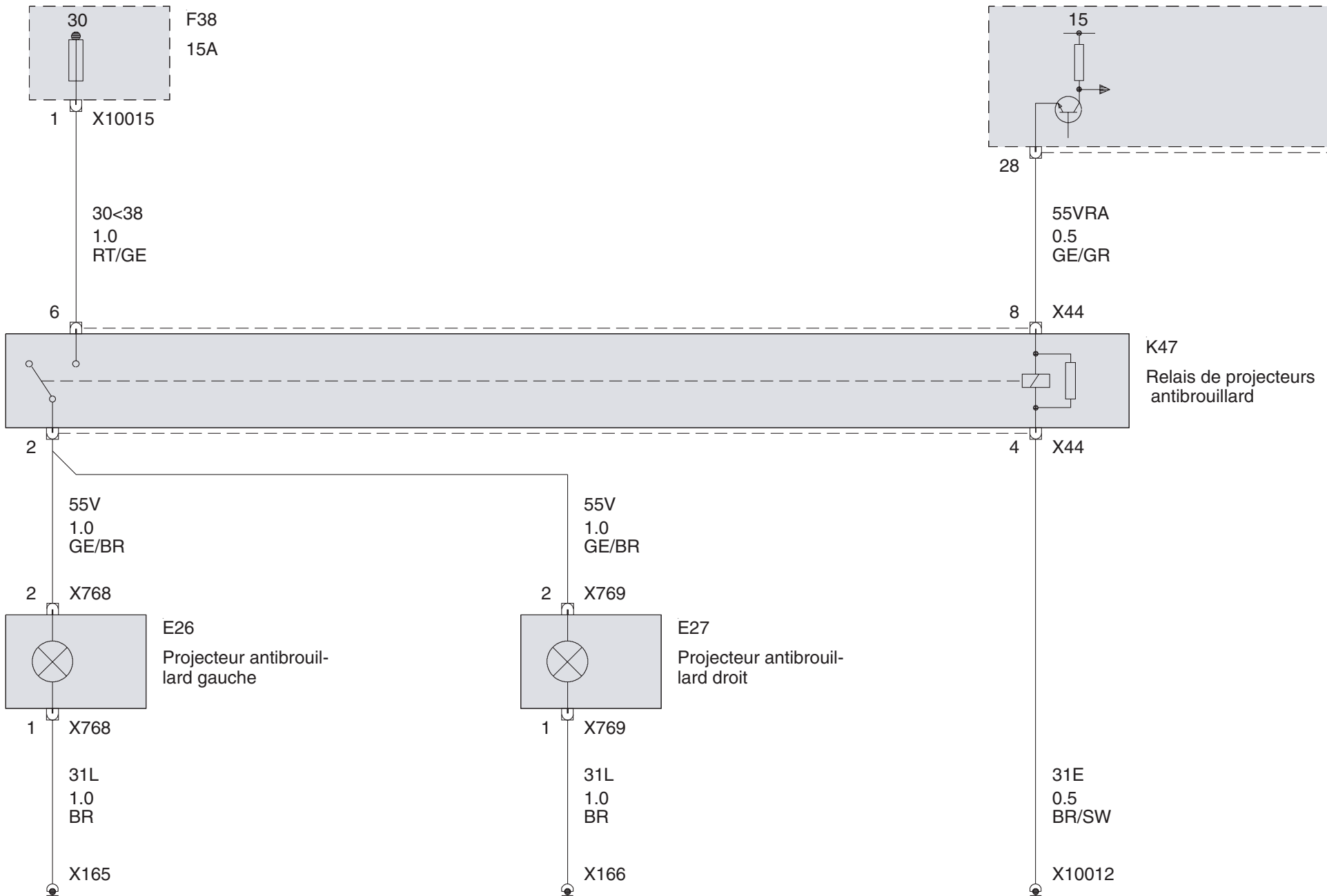



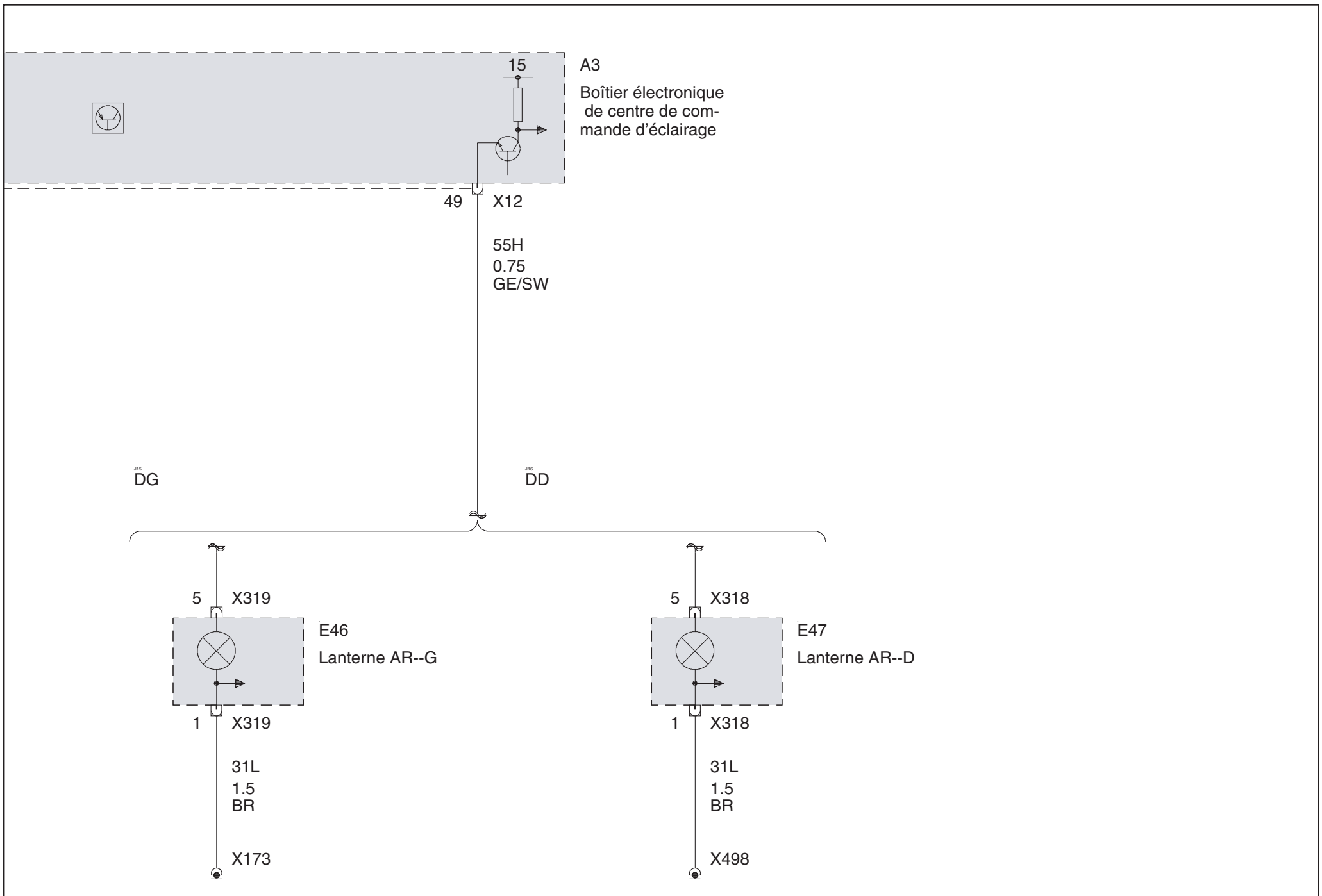

## Phare de recul

Phare de recul (Essence avec EGS Commande de boîte de vitesses 8.60.0 ou 8.60.4, sauf Compact)

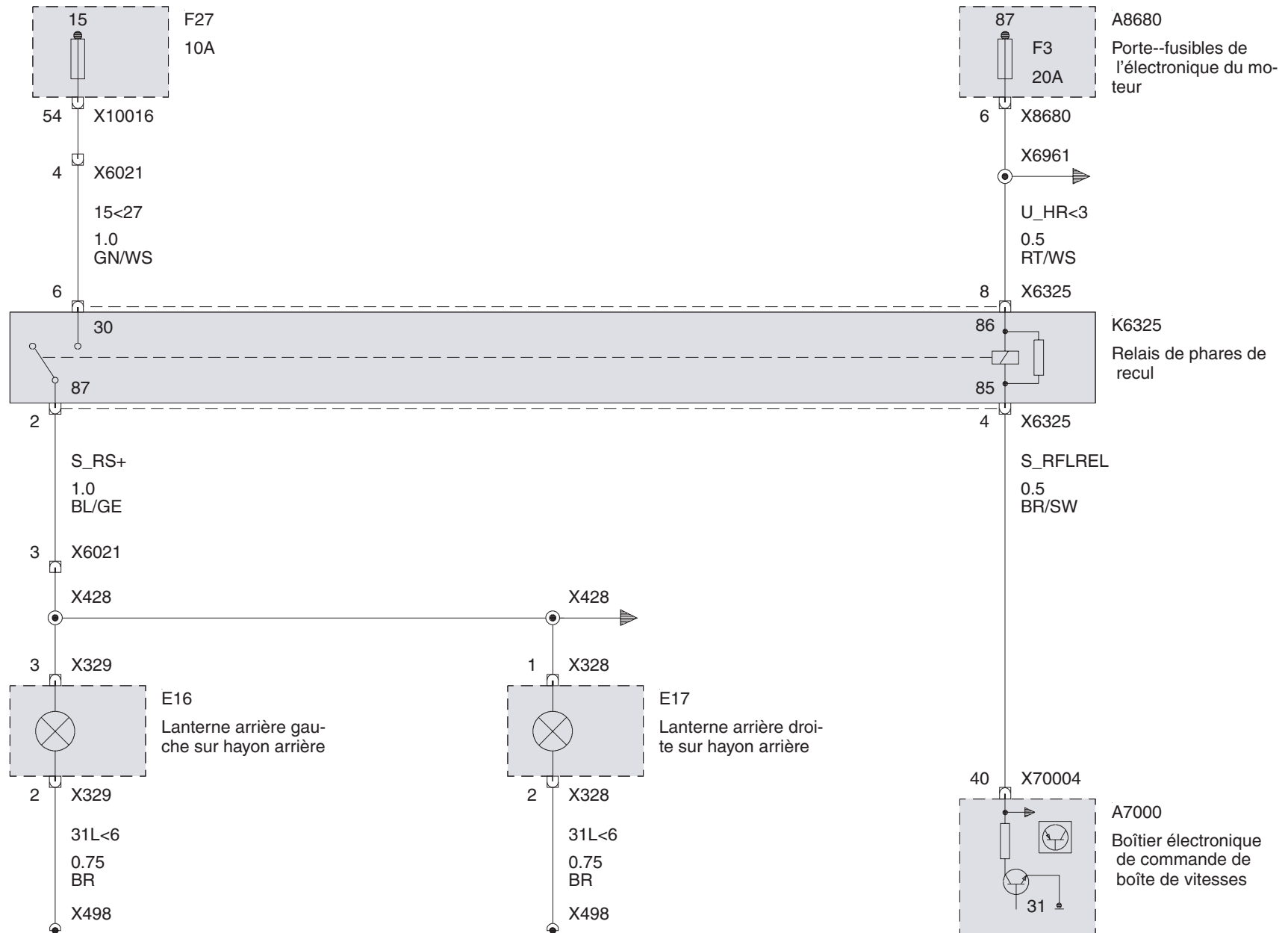

Phare de recul (Diesel sauf Compact sauf Moteur M57/TU)

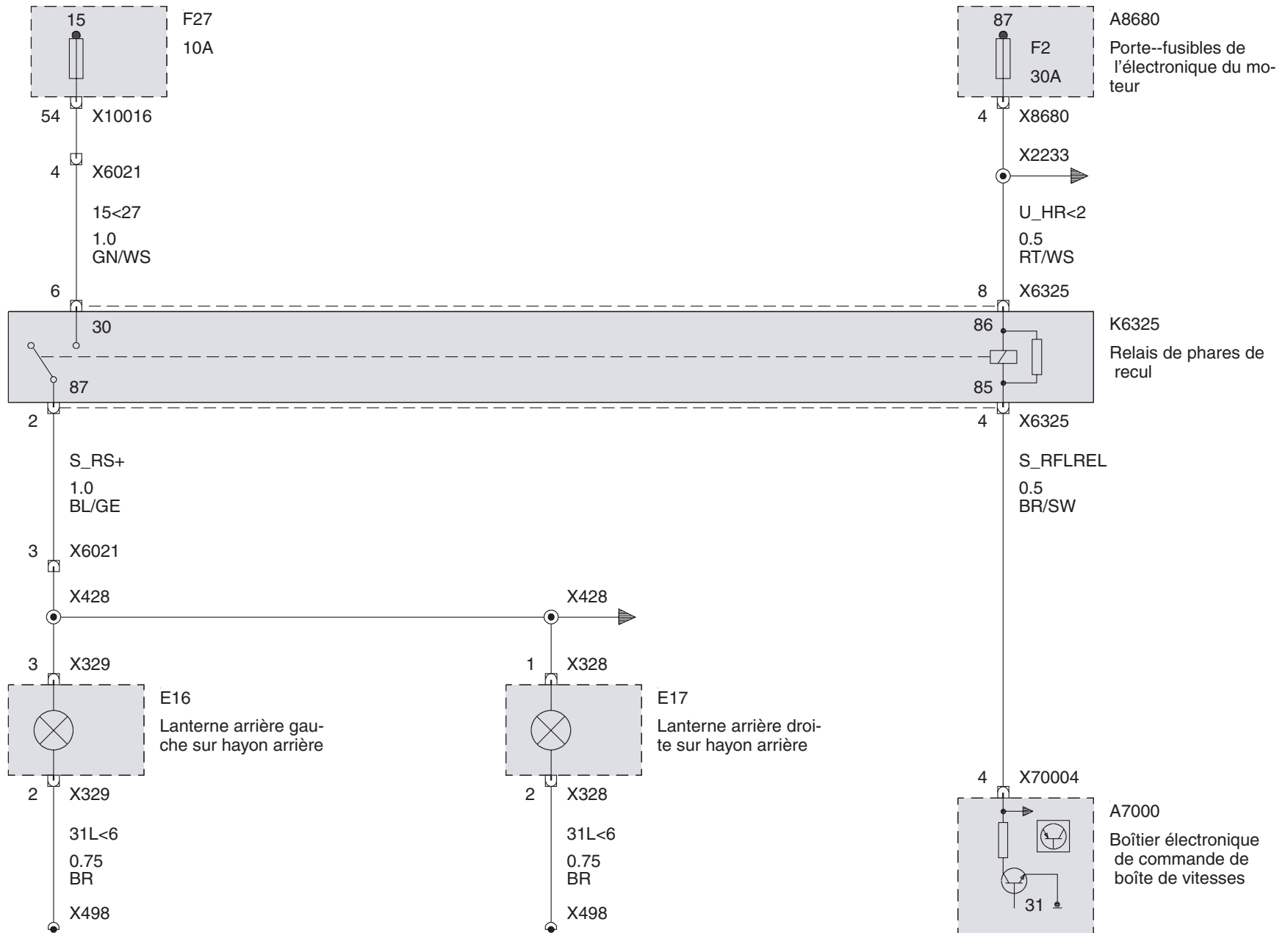

Phare de recul ( DME Electronique moteur ME9 ou MS43 avec EGS Commande de boîte de vitesses GS20, sauf Compact)

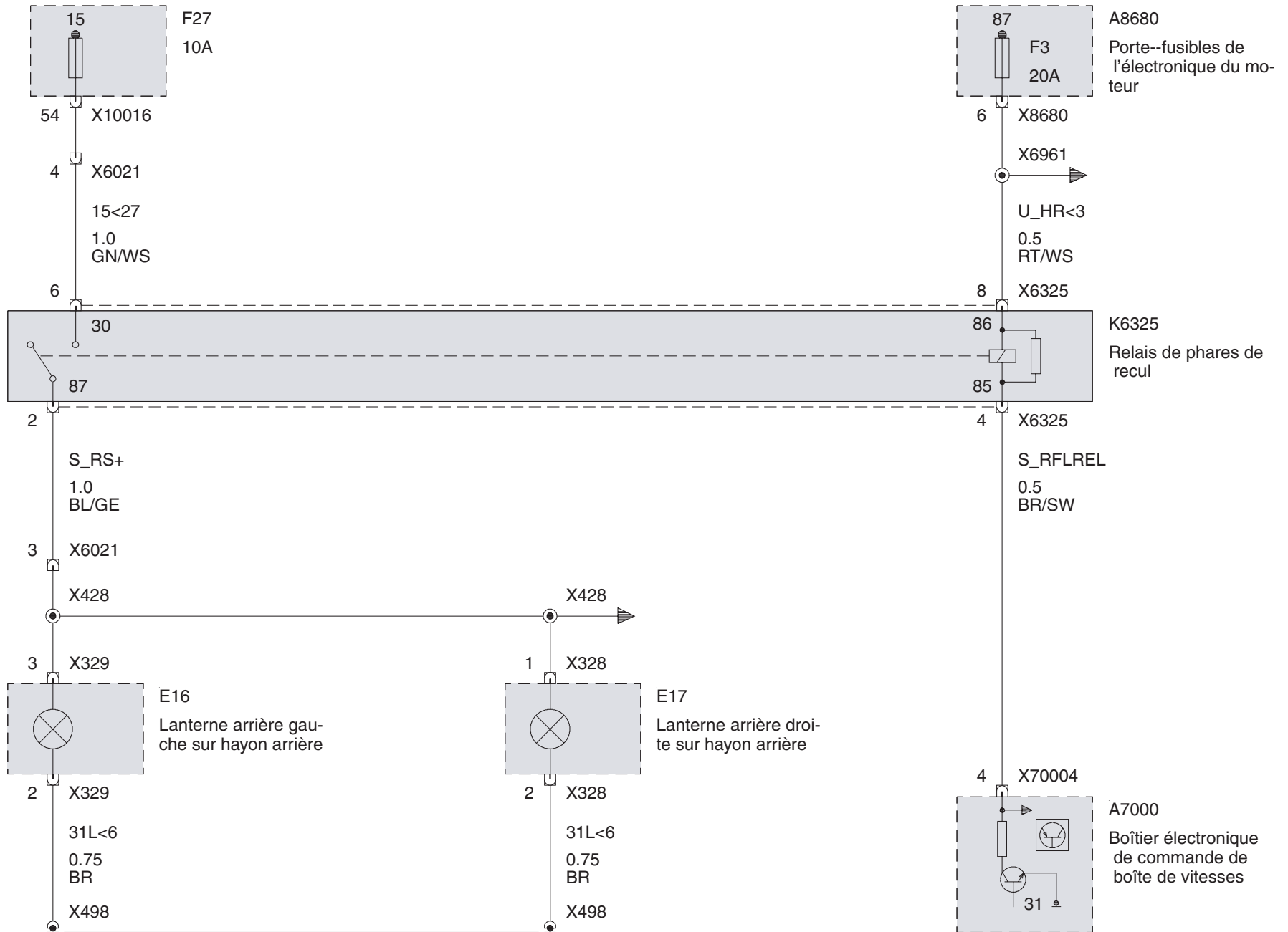

Phare de recul (Compact Essence avec Boîte automatique)

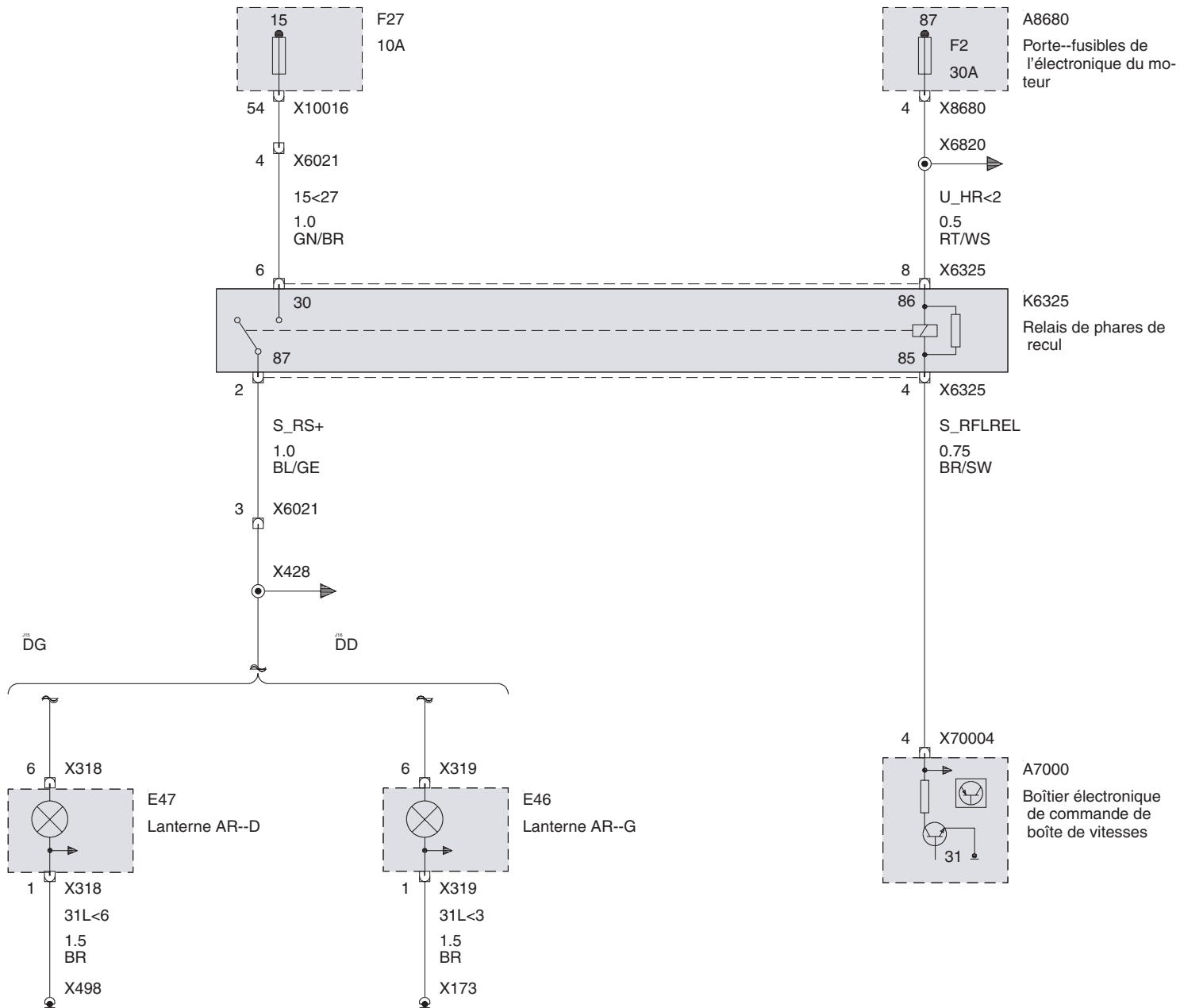



Phare de recul (Moteur M57/TU Boîte automatique sauf Compact)

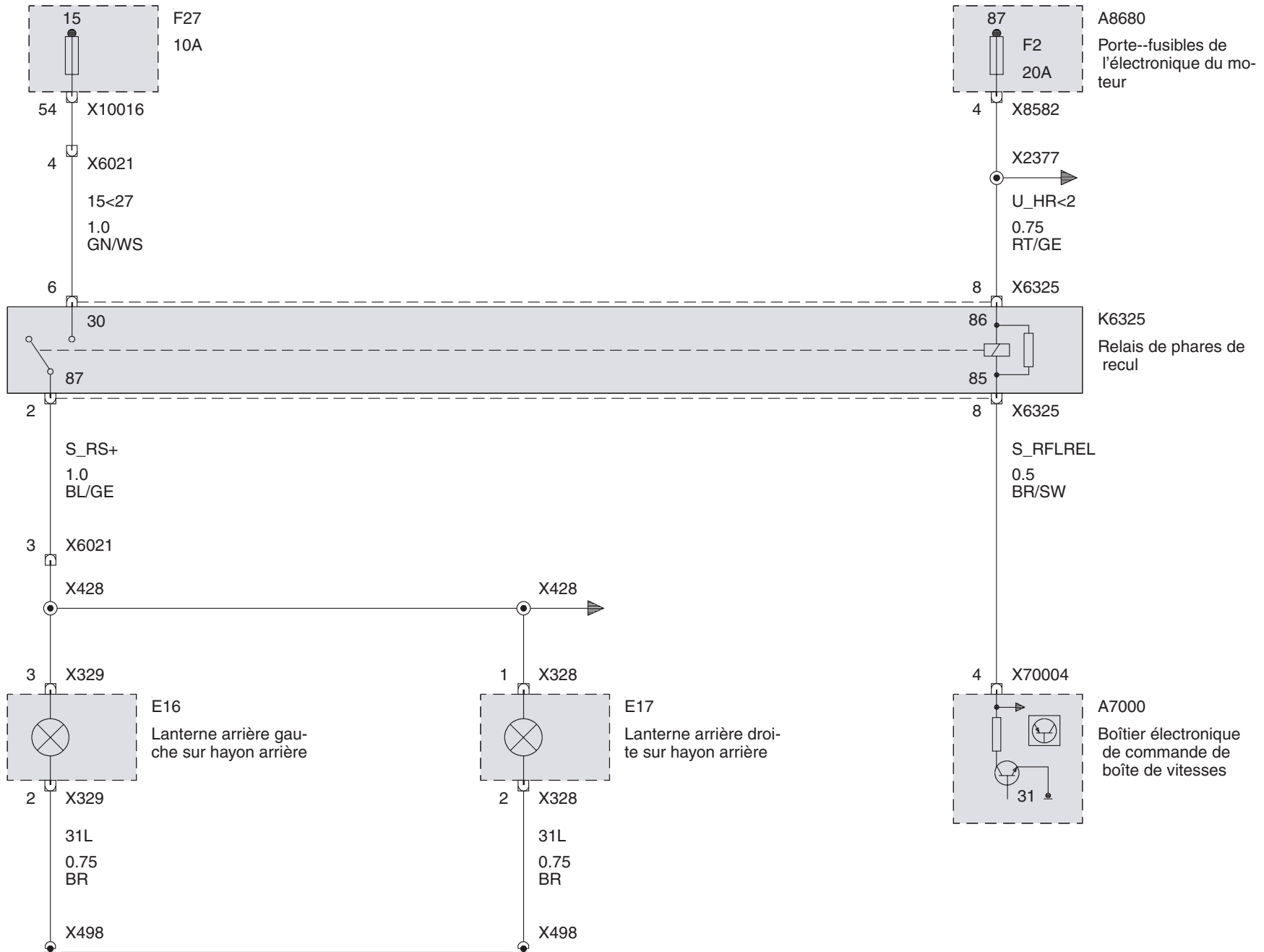

Phare de recul (Moteur M57/TU Boîte automatique avec Compact)

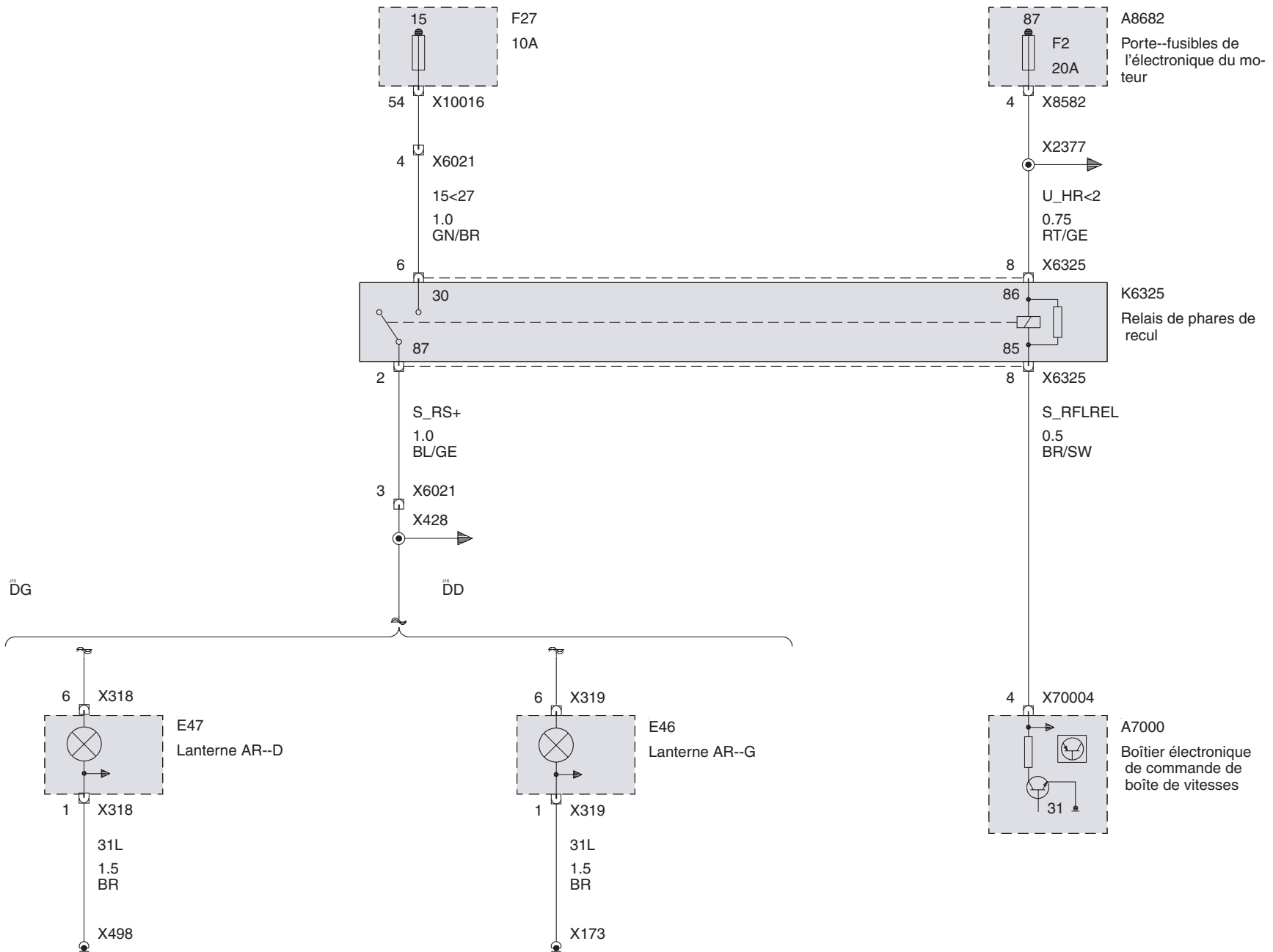



Phare de recul (Essence sans Boîte automatique sauf Compact)

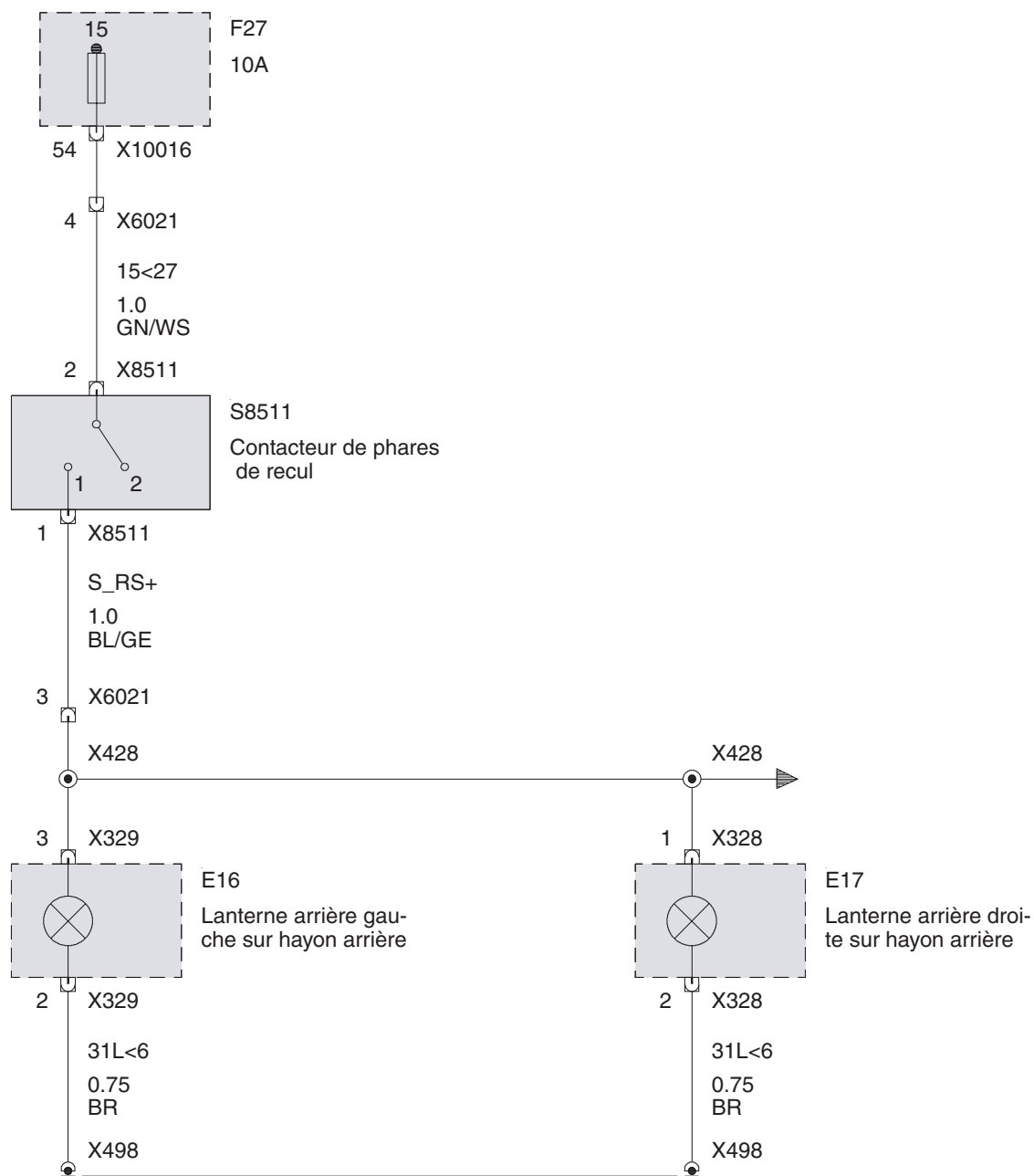

## Phare de recul (Diesel sans Boîte automatique sauf Compact)

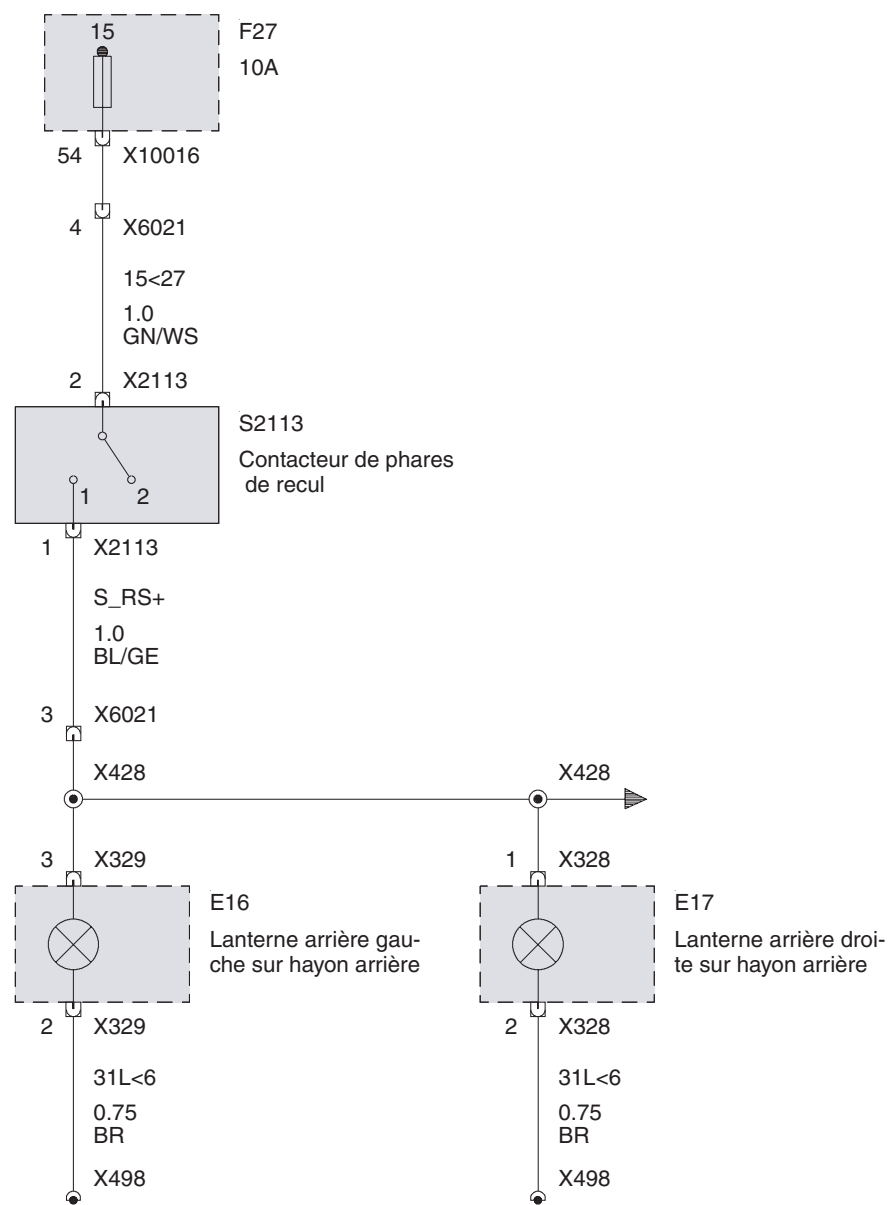

Phare de recul (Essence sans Boîte automatique avec Compact)

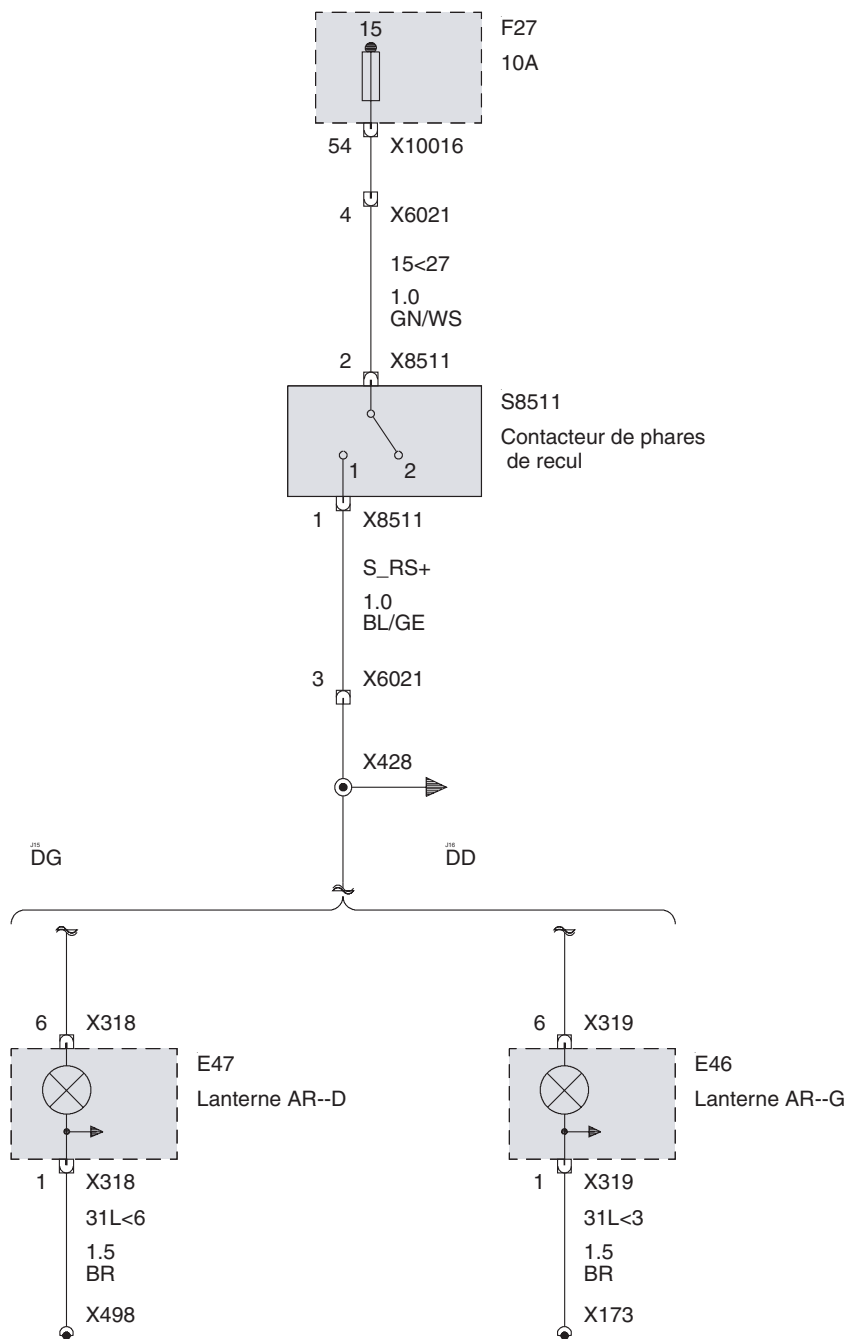

Phare de recul (sans Boîte automatique avec Diesel avec Compact)

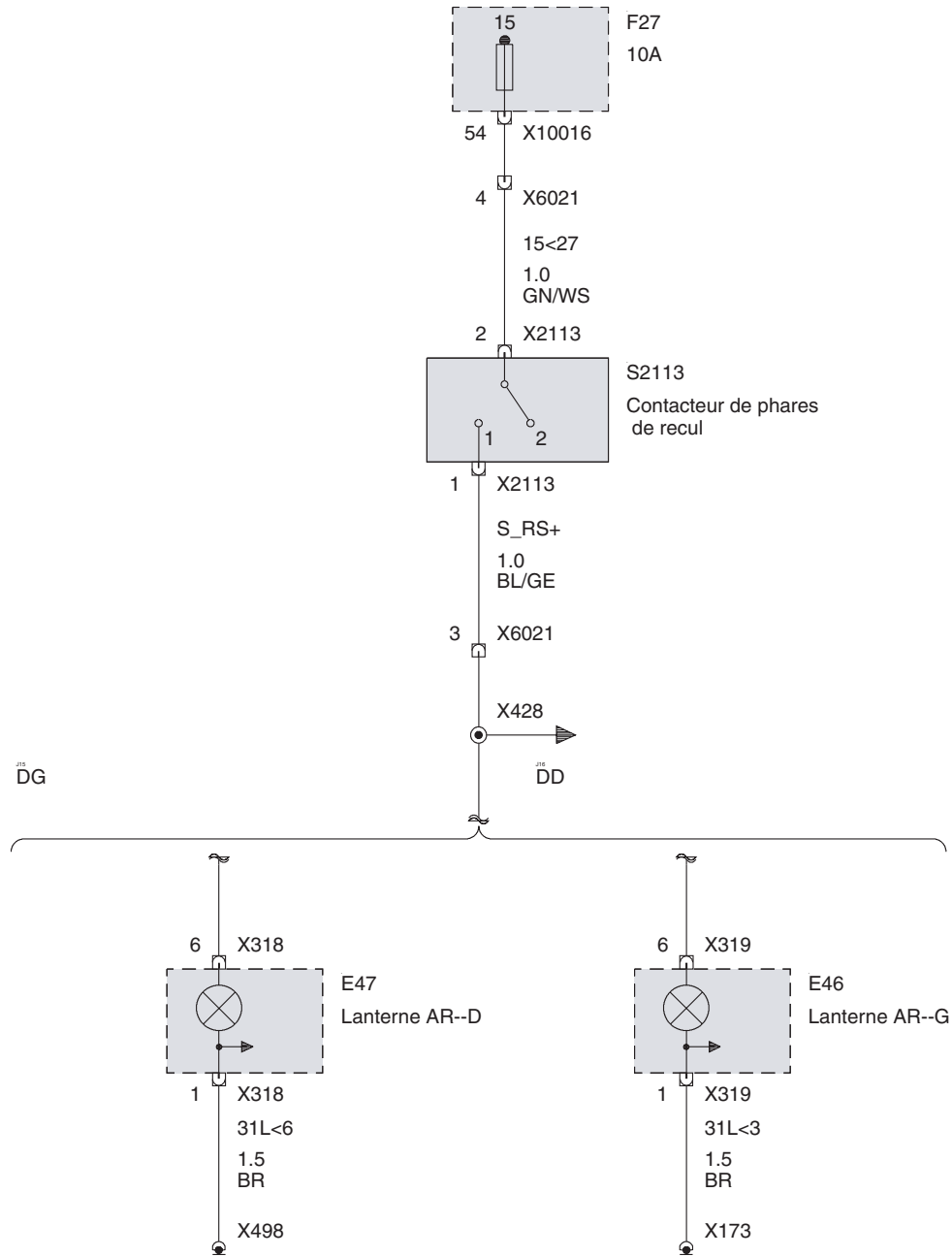

Eclairage remorque

Alimentation (Diesel sans Boîte automatique)

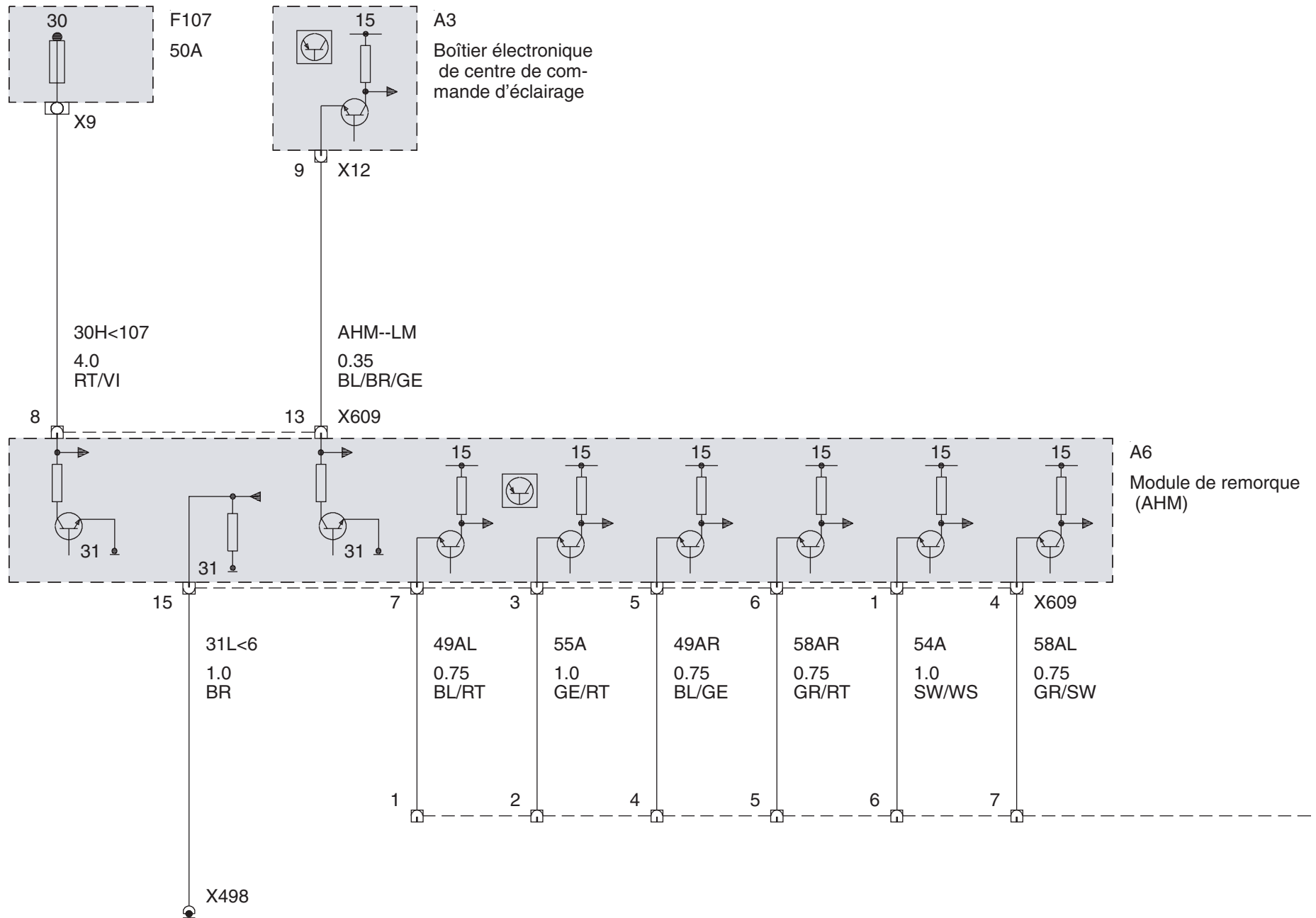

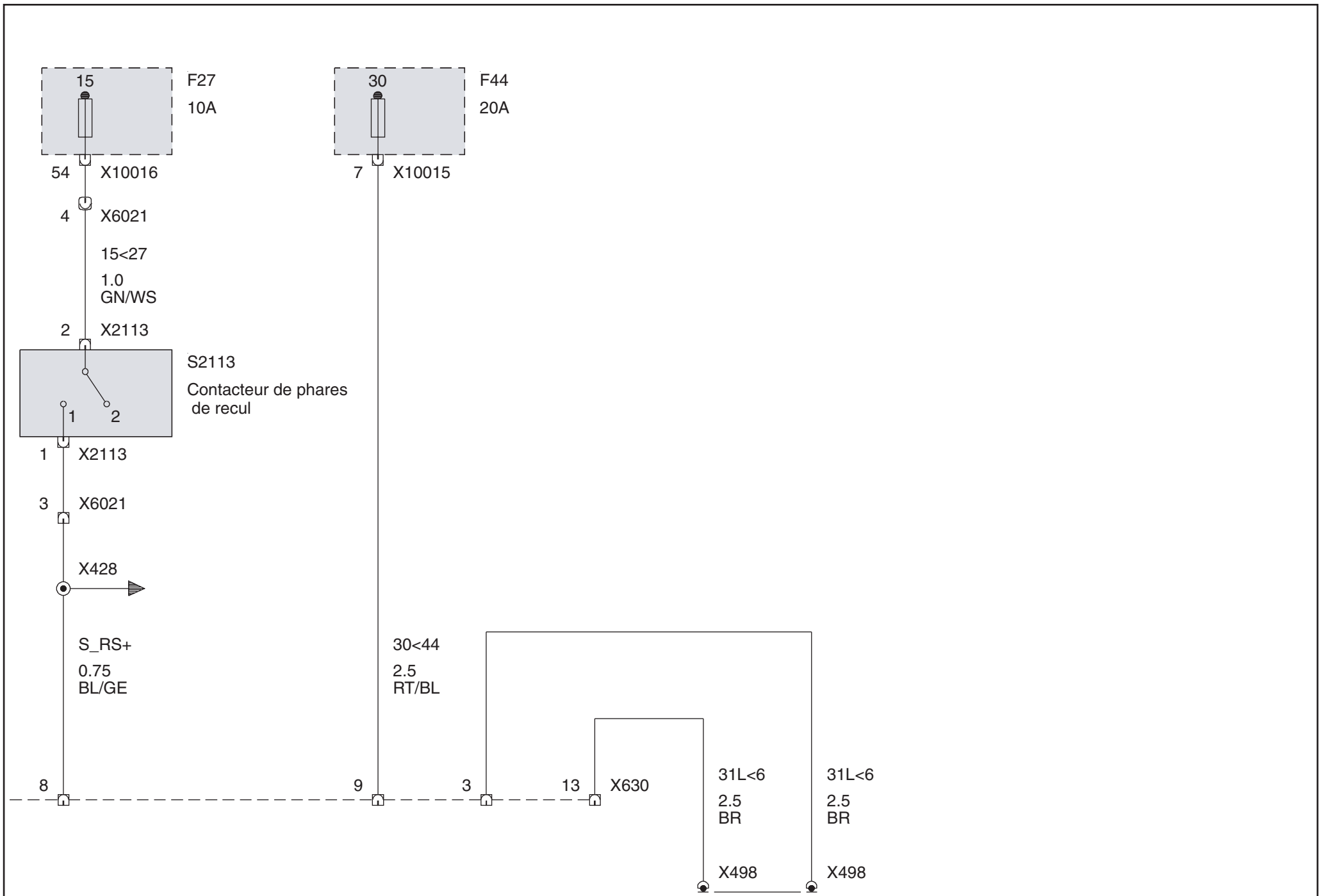

Alimentation (Essence sans Boîte automatique)

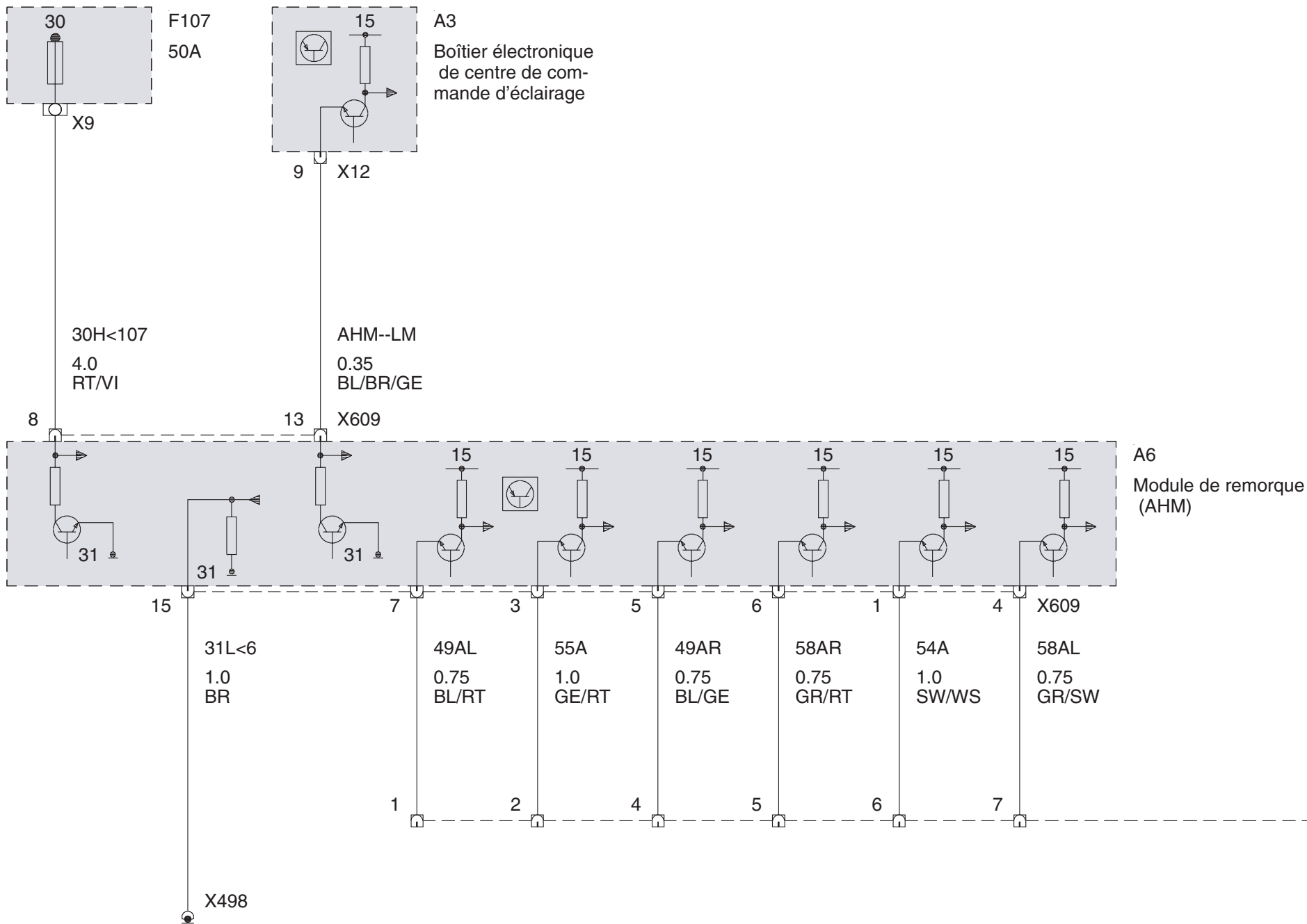

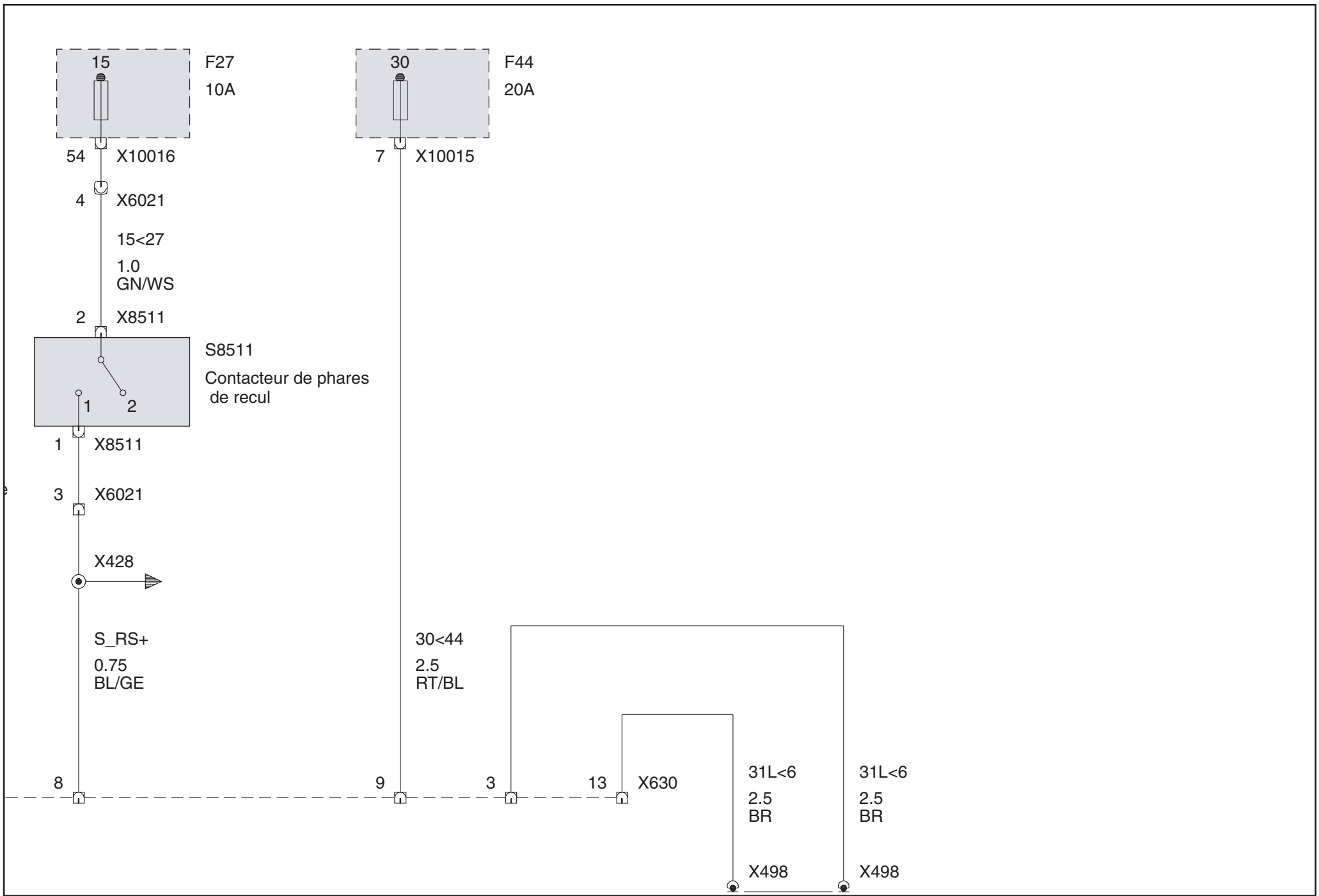



Alimentation (Boîte automatique)

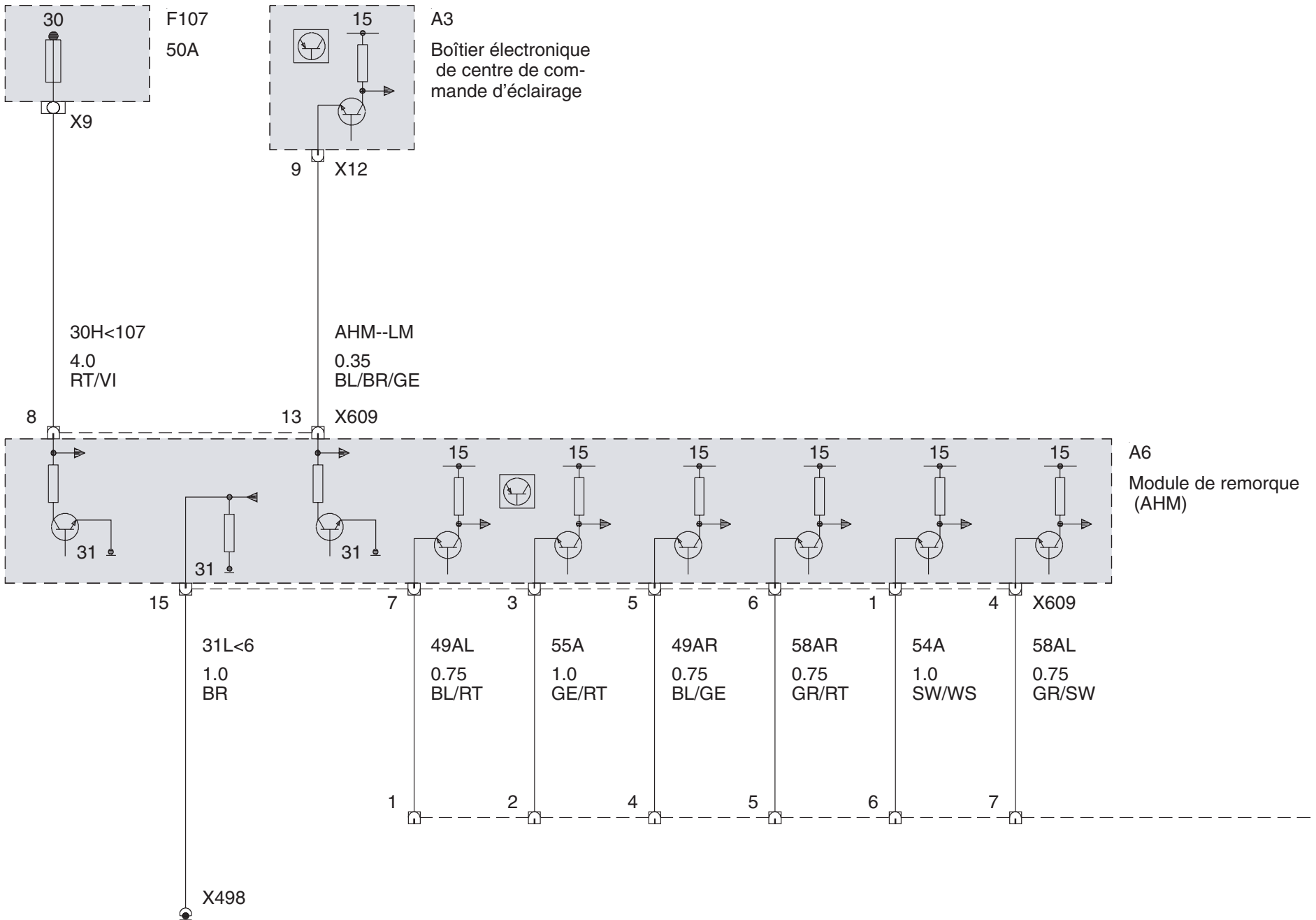

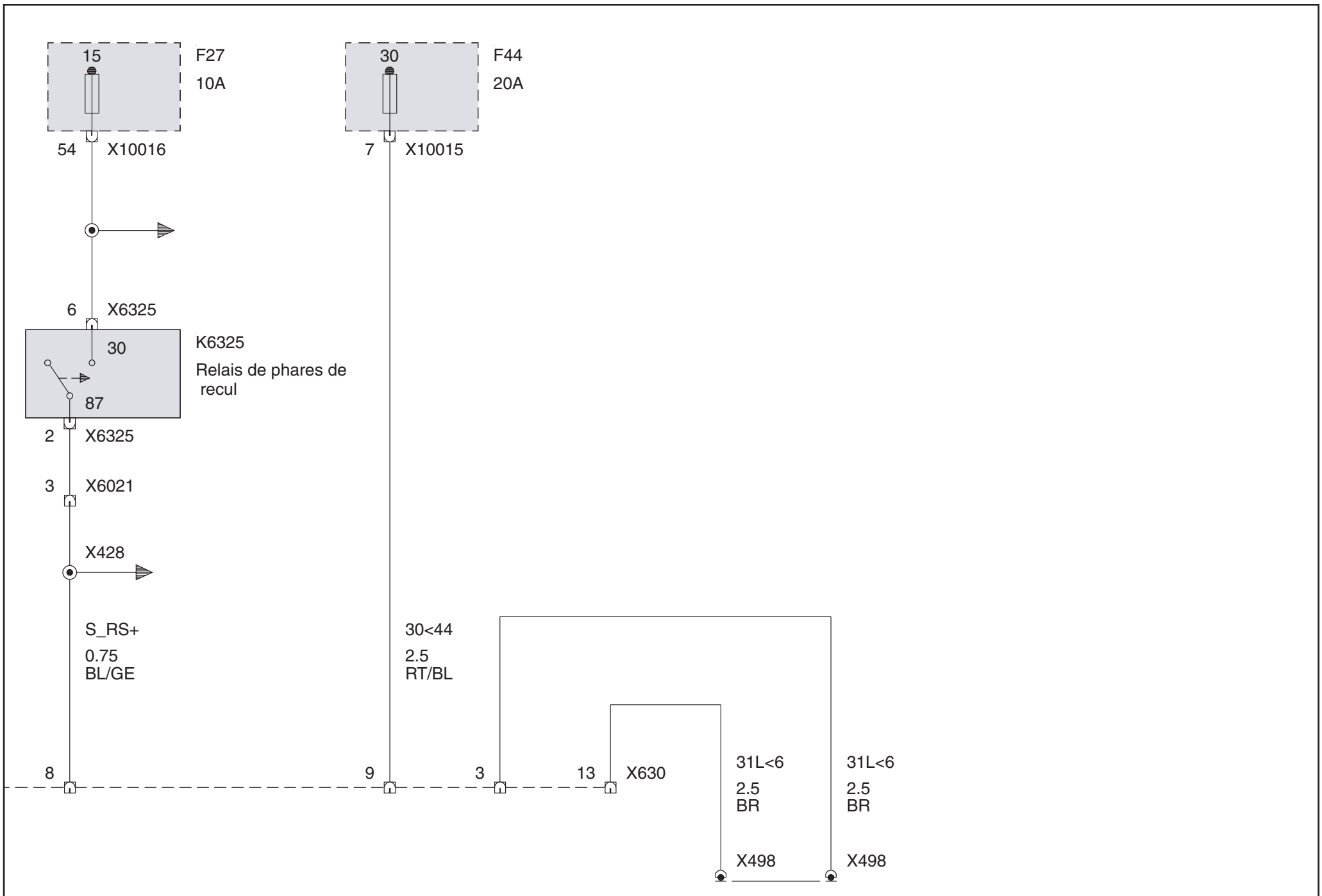

Côté droit de la remorque

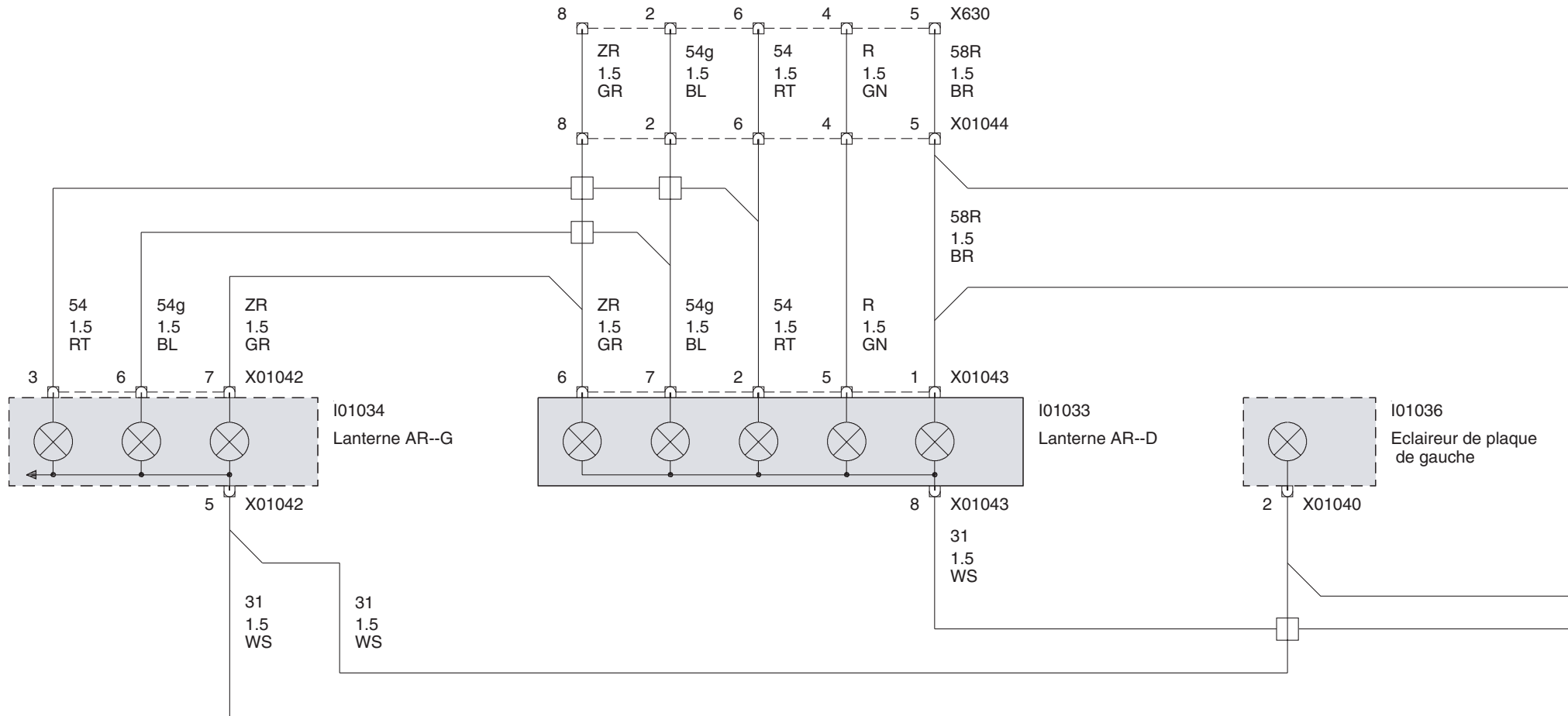

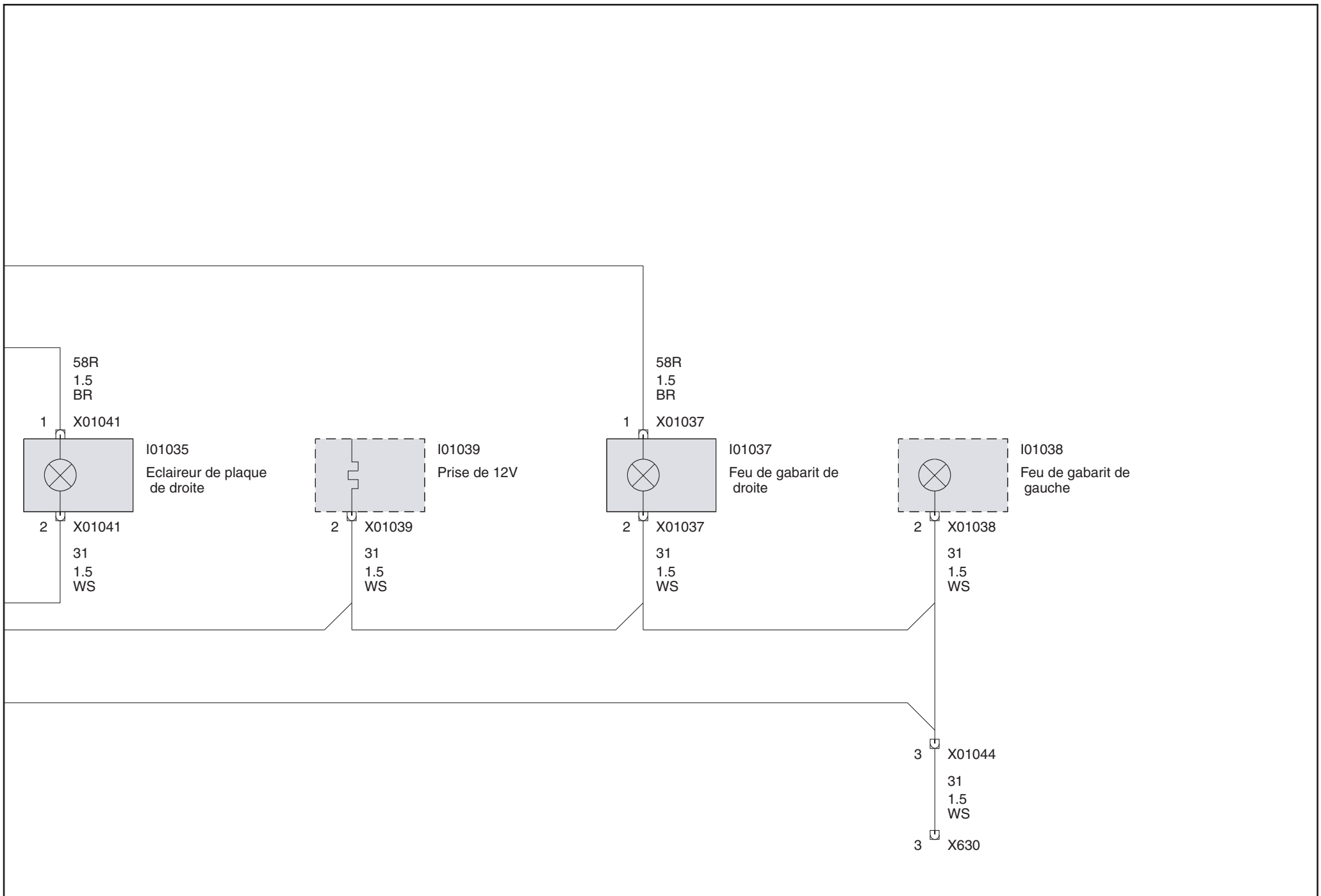

Côté gauche de la remorque

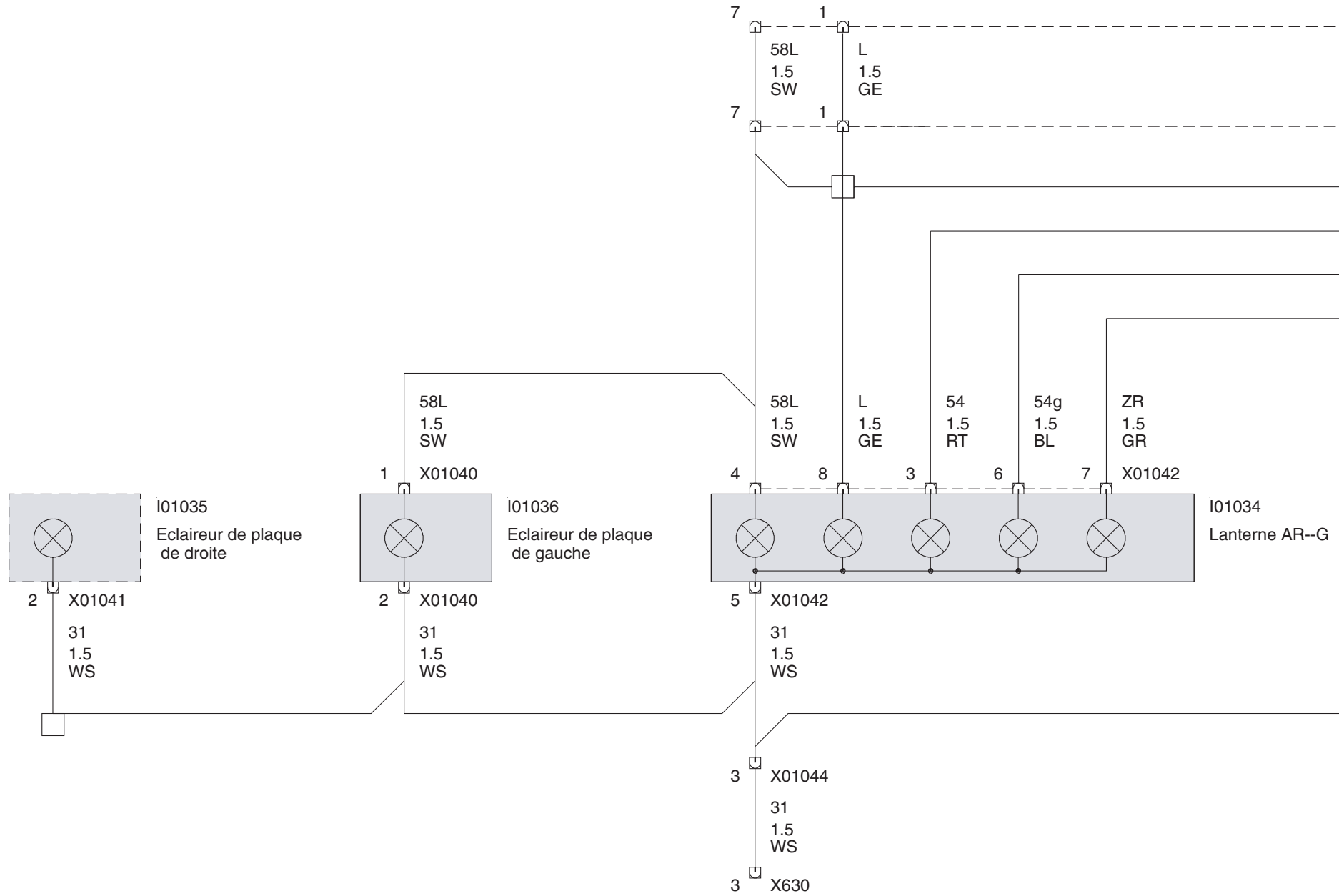

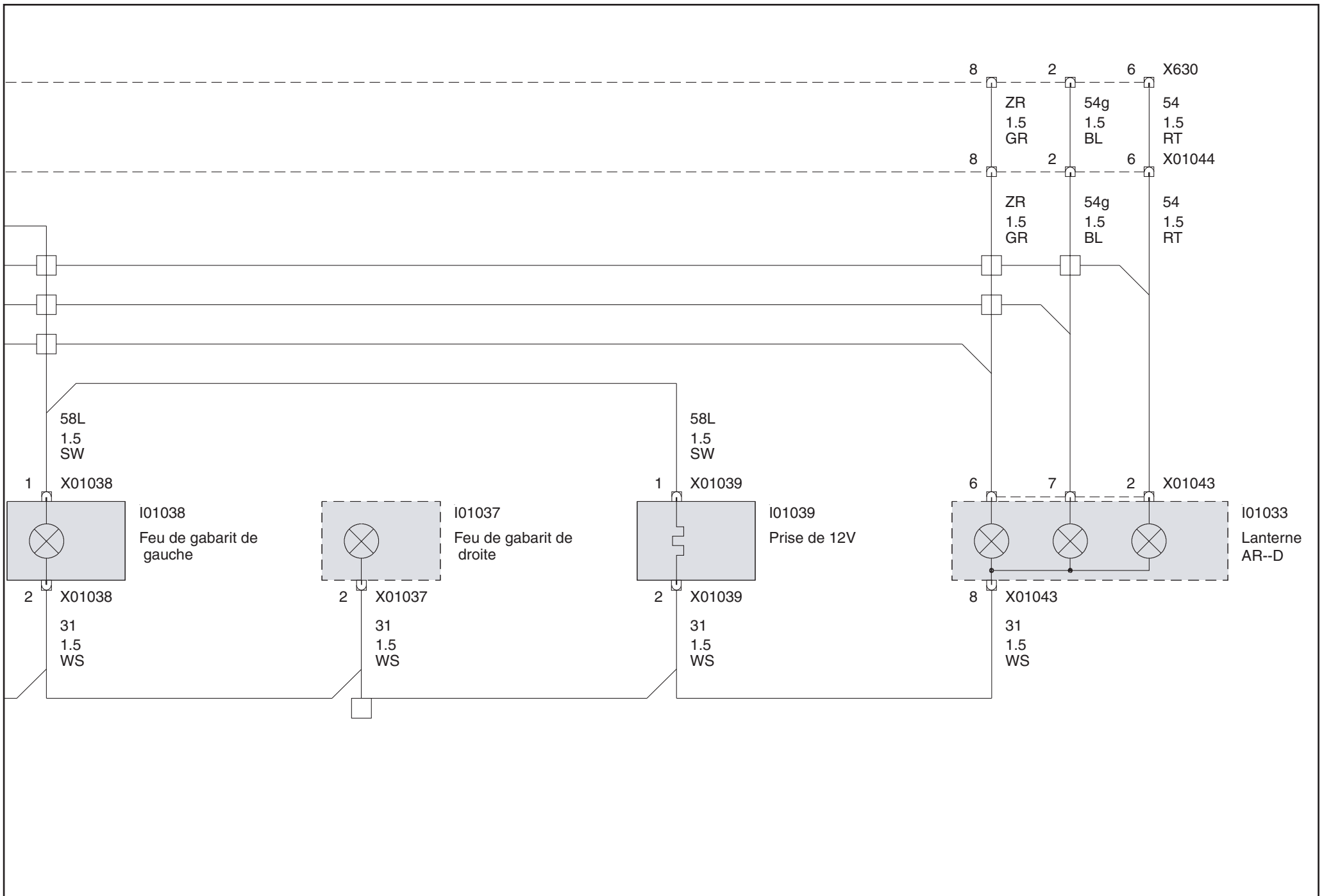

## Feu rouge arrière gauche (Berline)

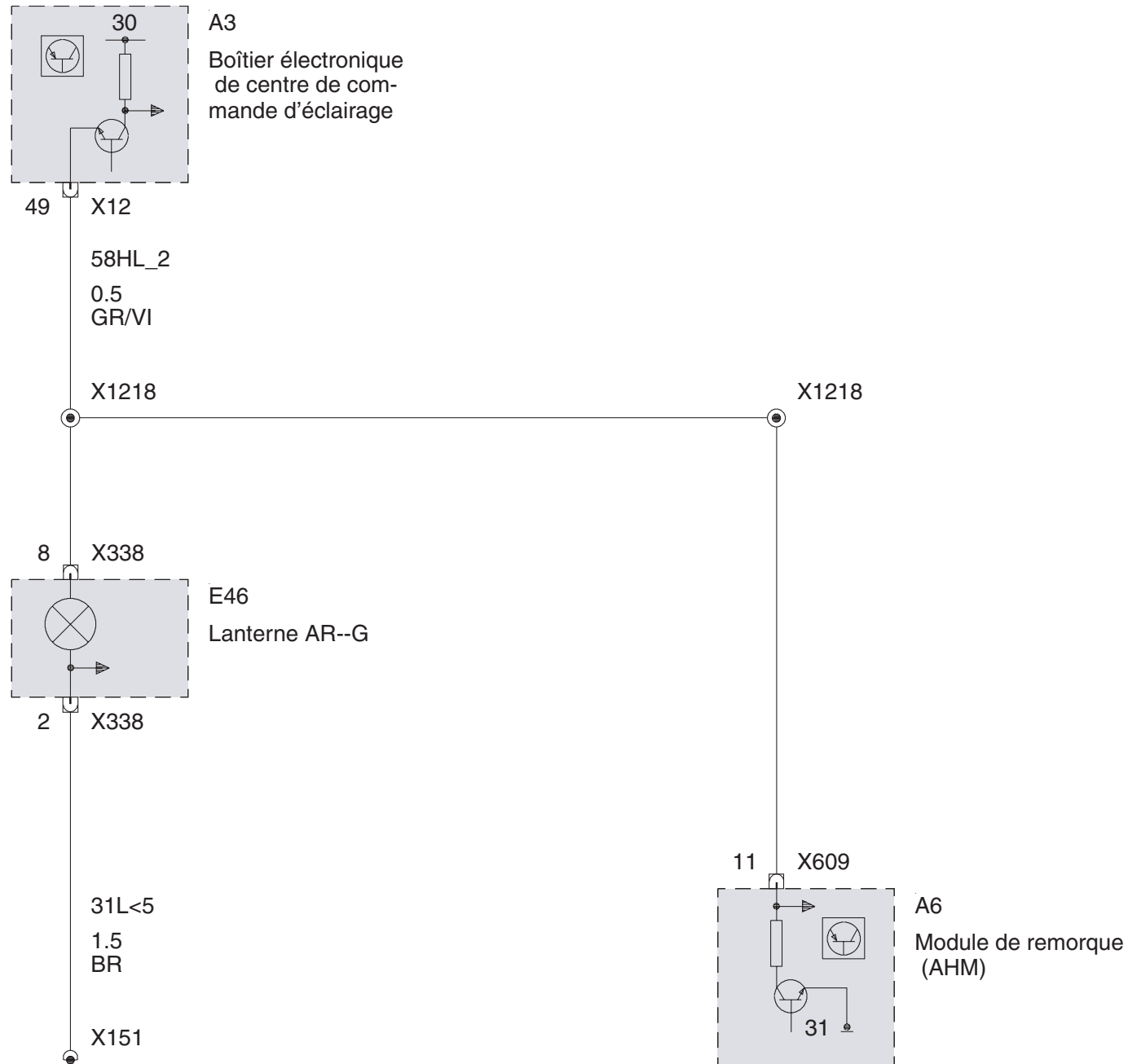

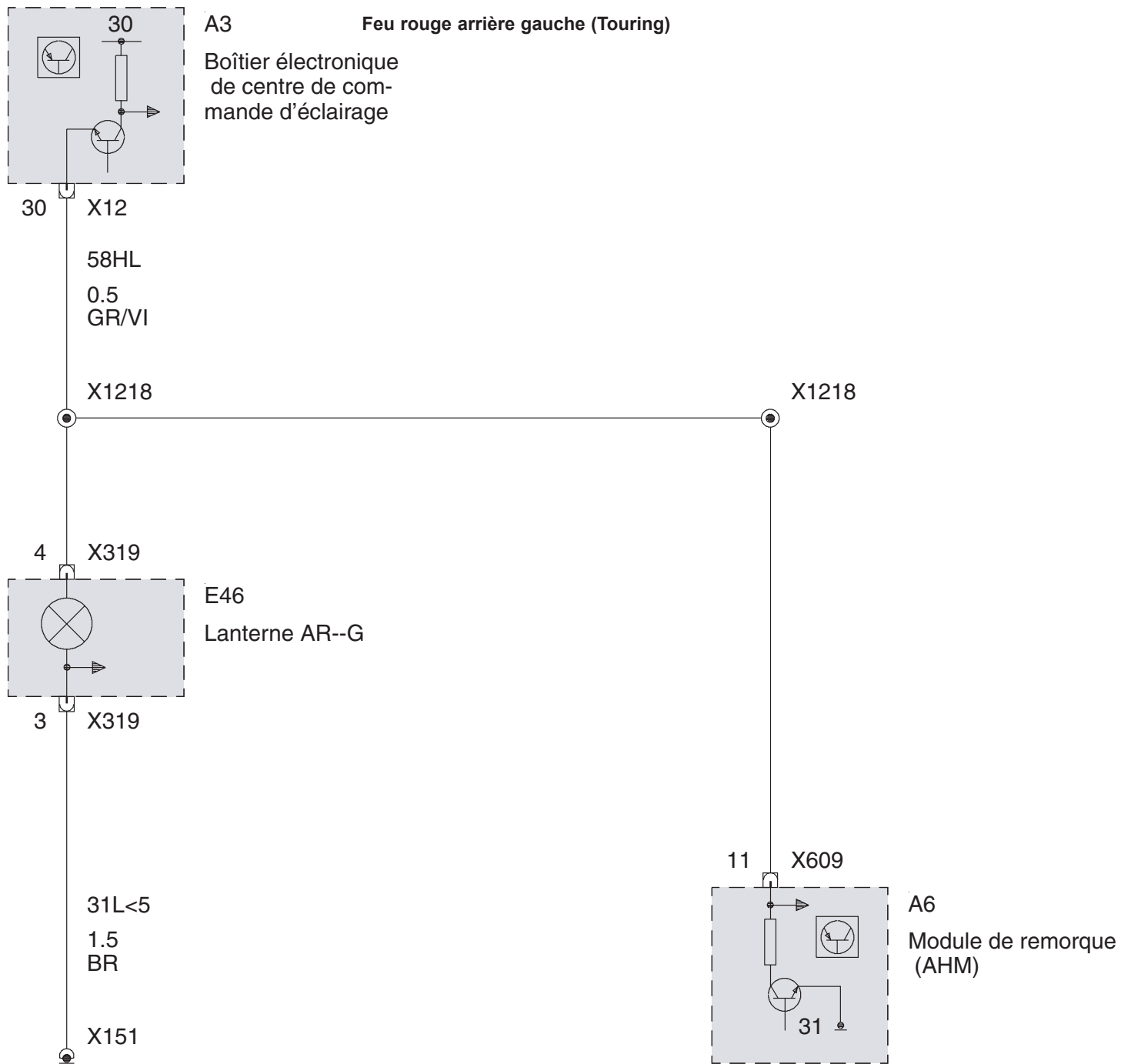



## Feu rouge arrière gauche ( Coupé ou Cabriolet )

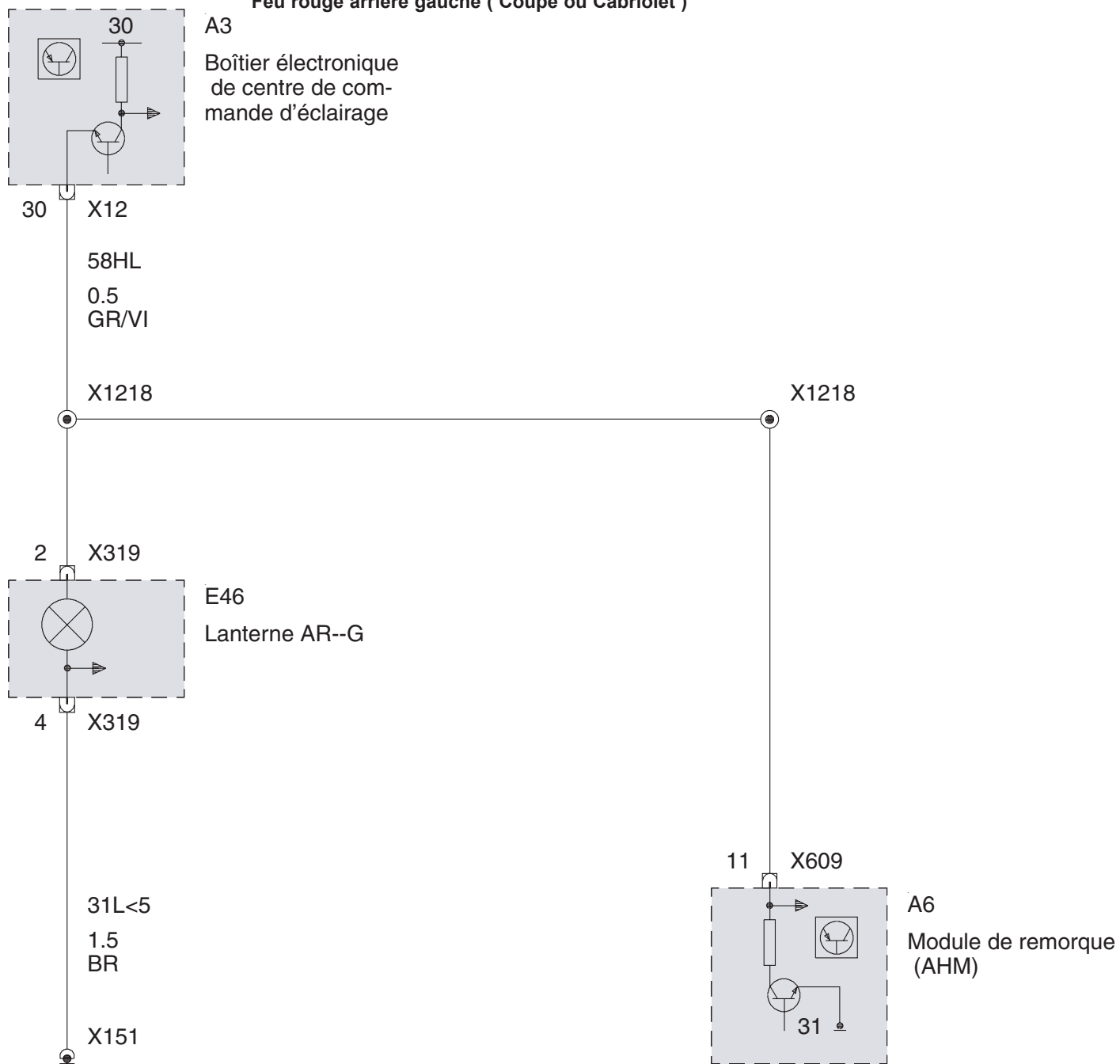

Feu rouge arrière gauche (Compact)

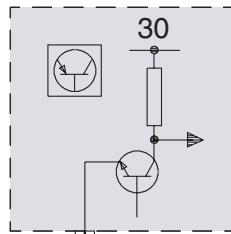

A3  
Boîtier électronique  
de centre de com-  
mande d'éclairage

5 X12

58HL  
0.75  
GR/VI

X1218

4 X319

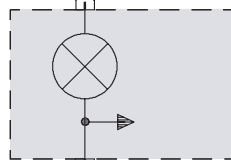

E46  
Lanterne AR--G

1 X319

31L<3  
1.5  
BR

X173

X1218

11 X609

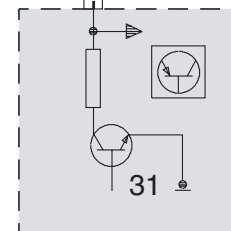

A6  
Module de remorque  
(AHM)

31

## Feu rouge arrière droit (Berline)

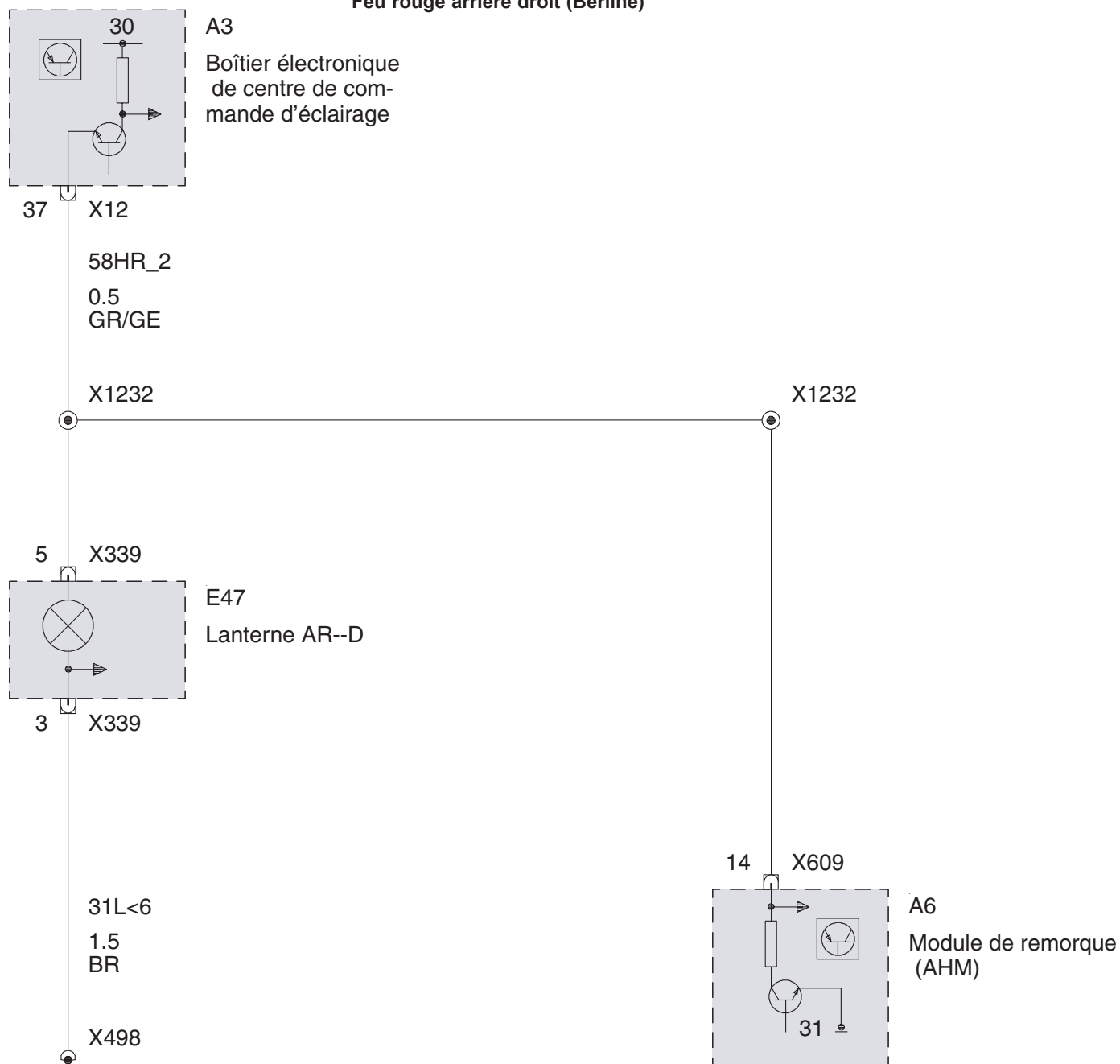

## Feu rouge arrière droit (Touring)

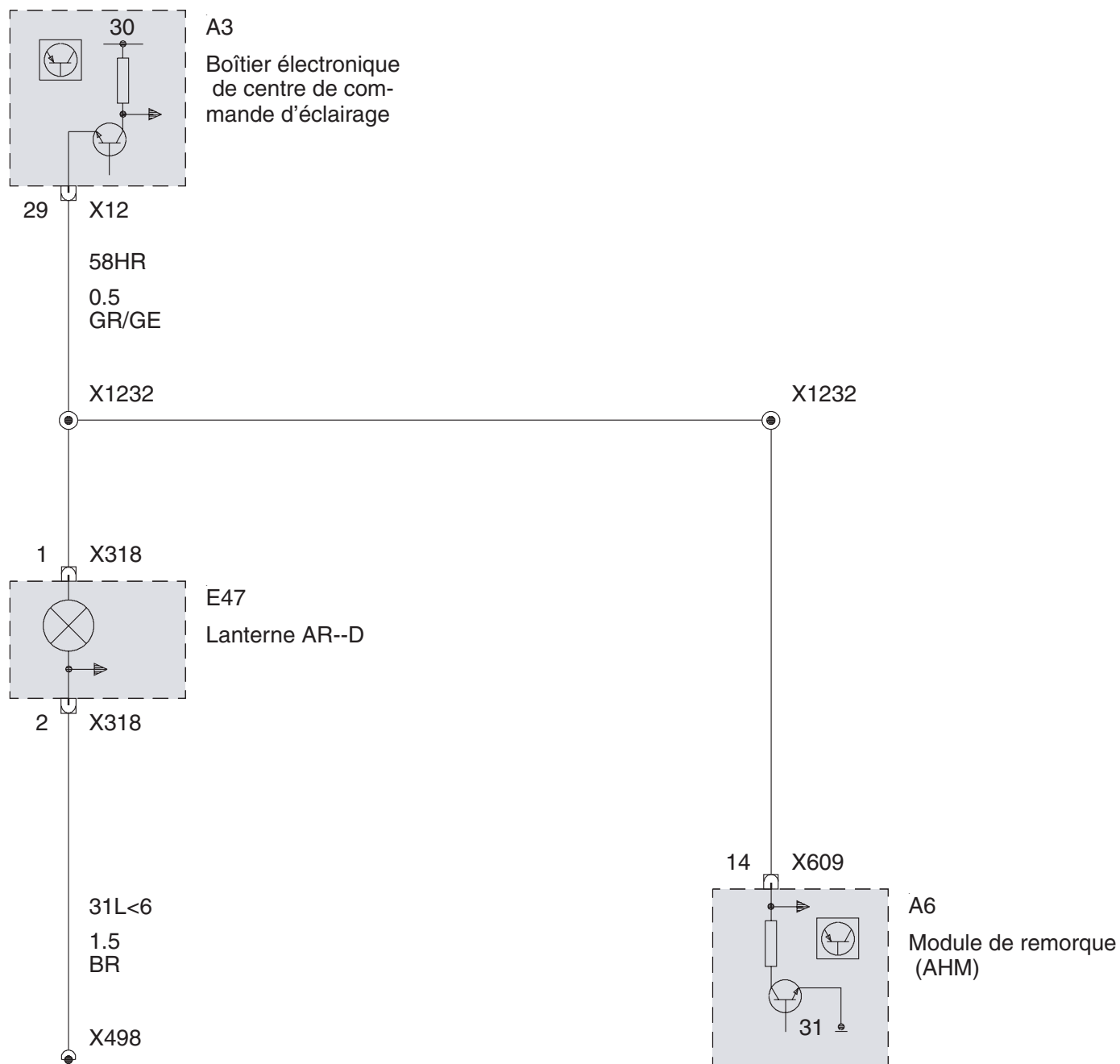

## Feu rouge arrière droit (Coupé ou Cabriolet)

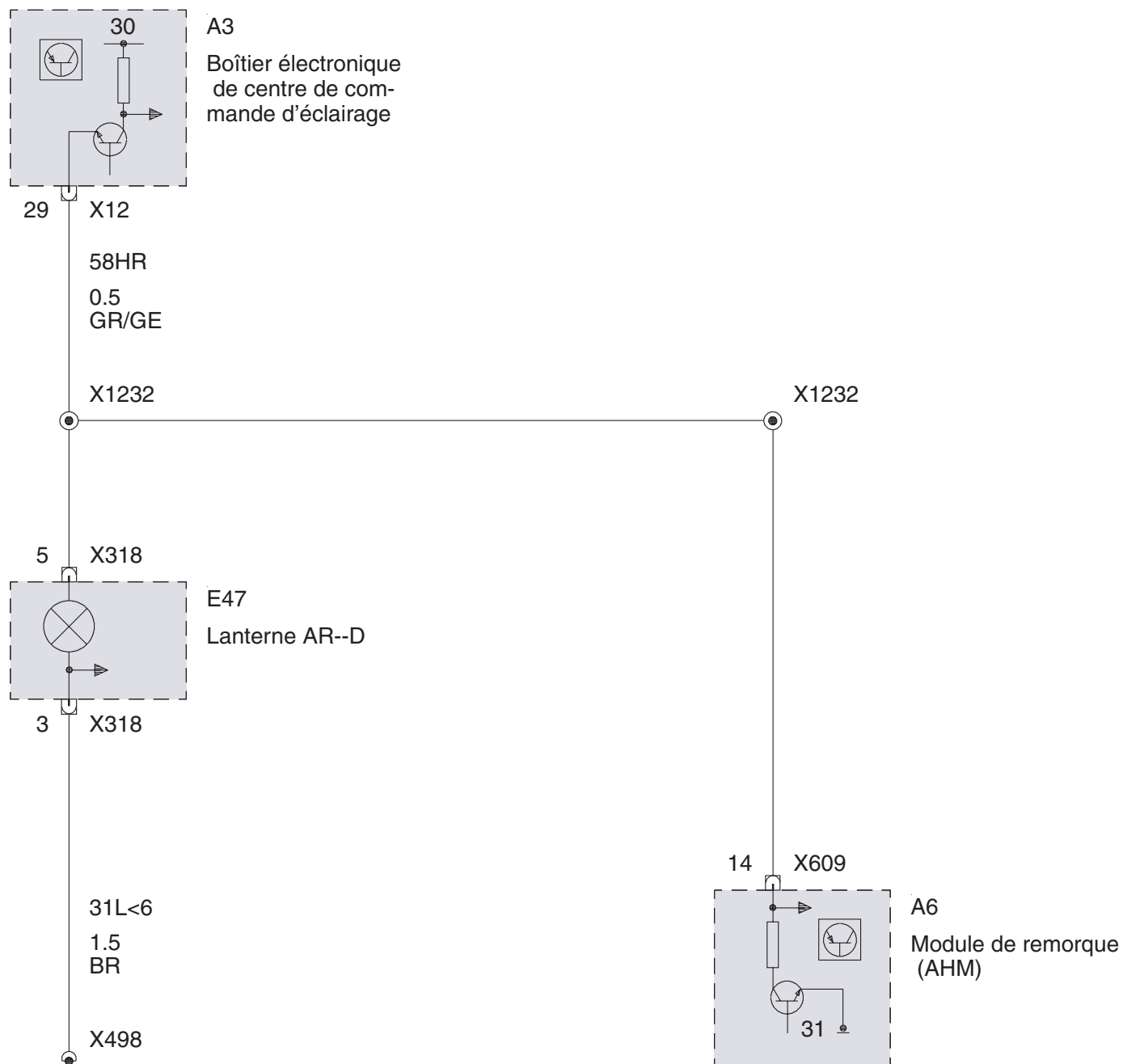

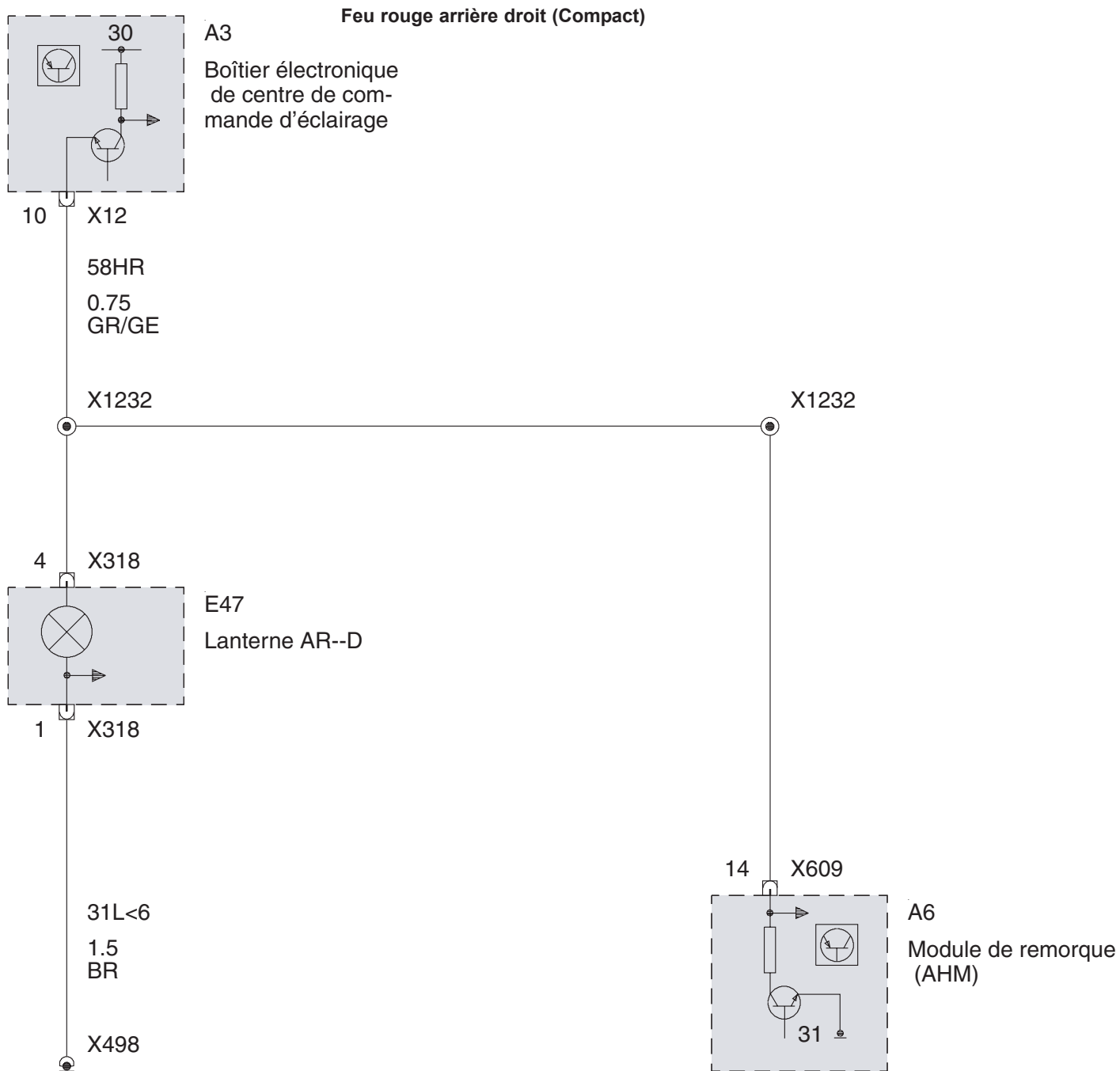

## Feux stop (Berline)

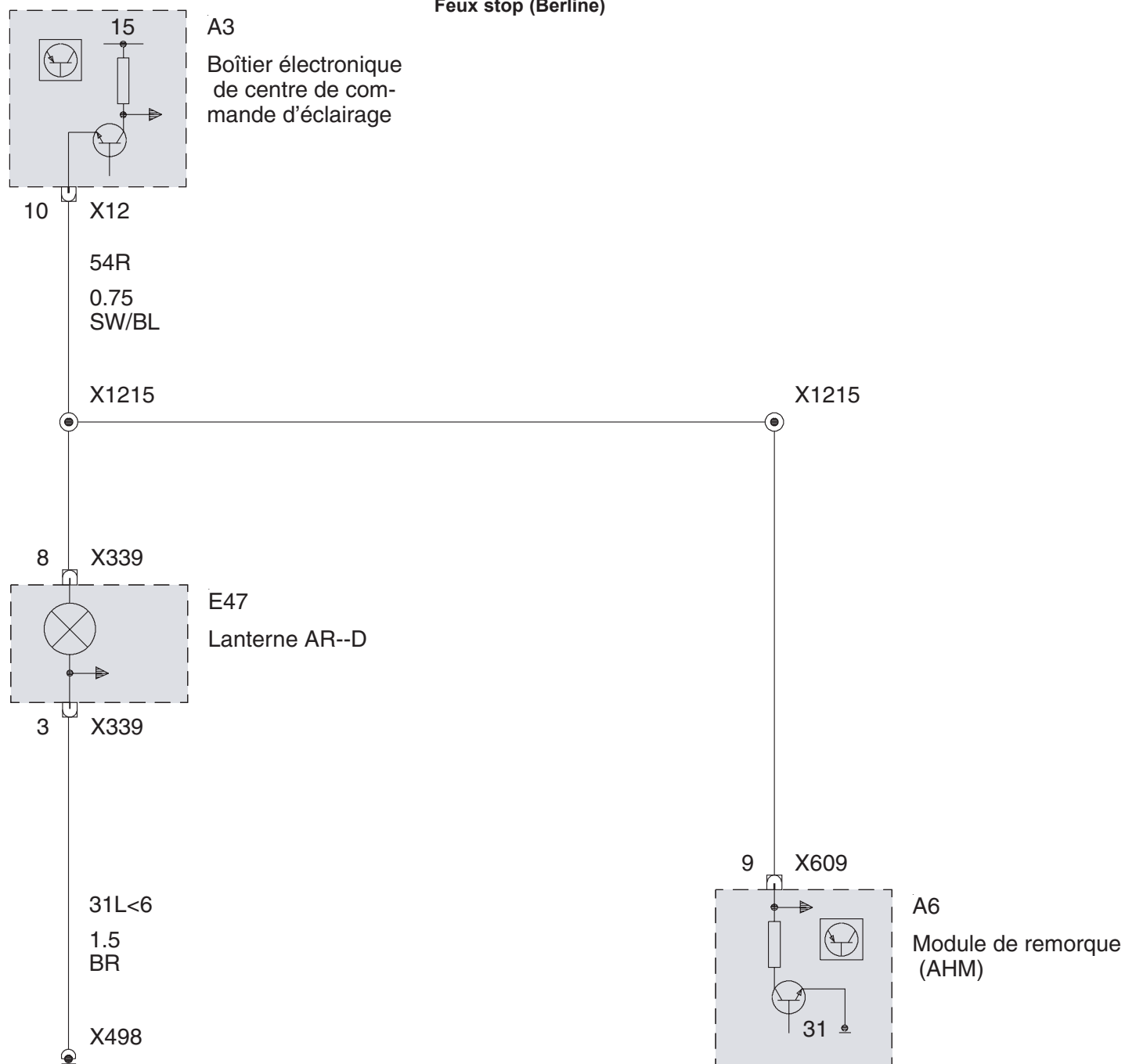

## Feux stop (Touring)

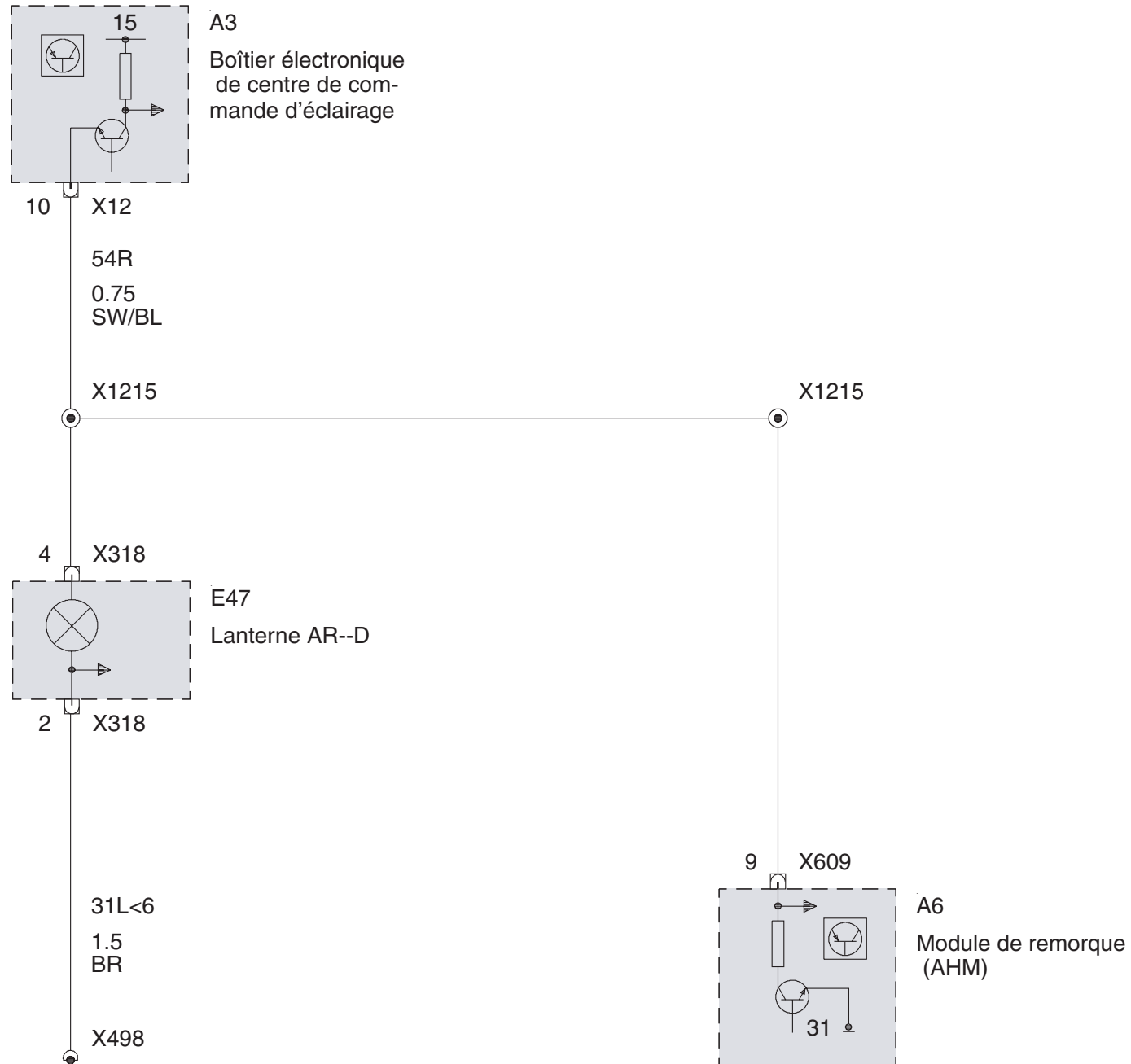



Feux stop (Coupé ou Cabriolet)

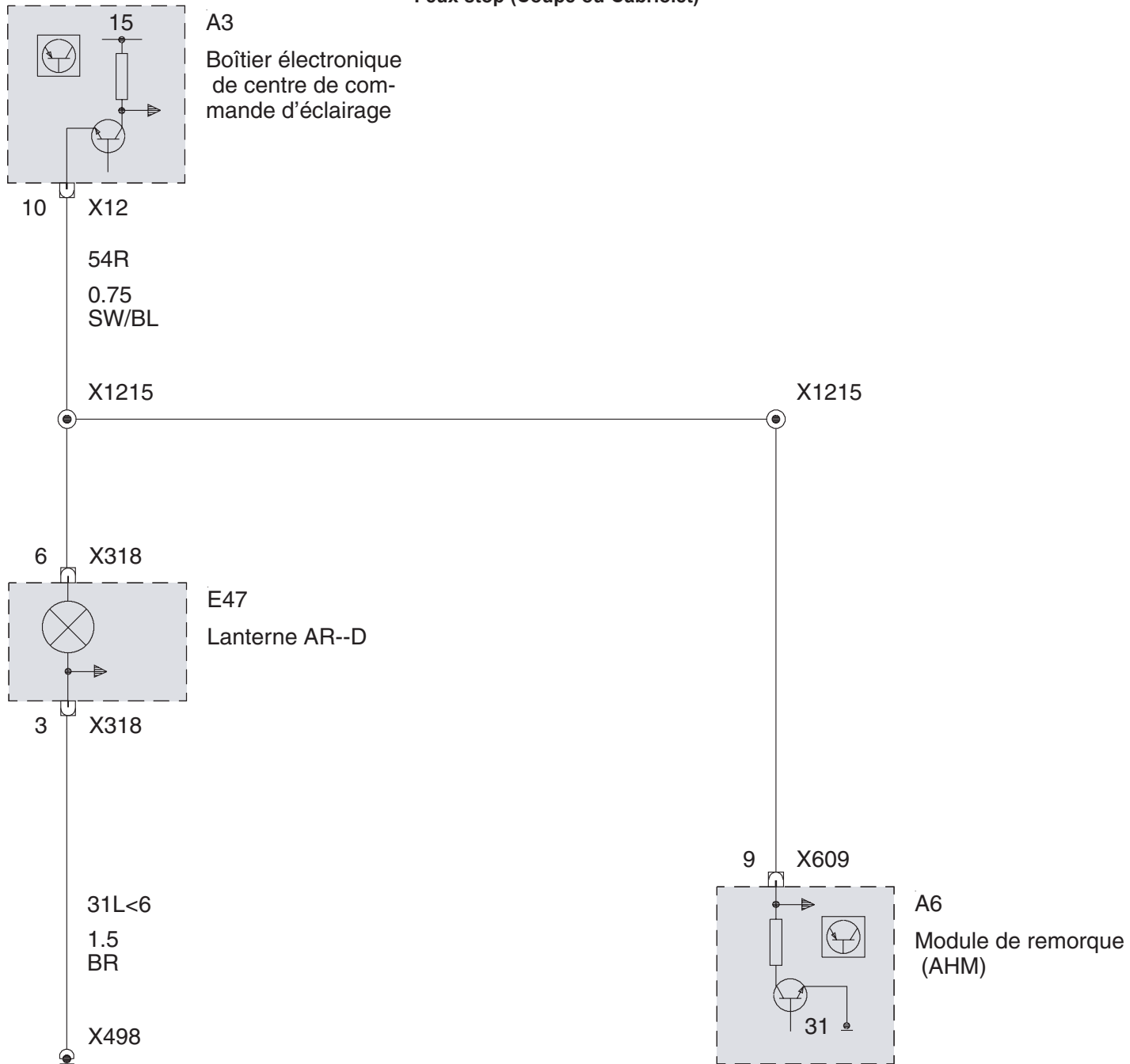

Feux stop (Compact)

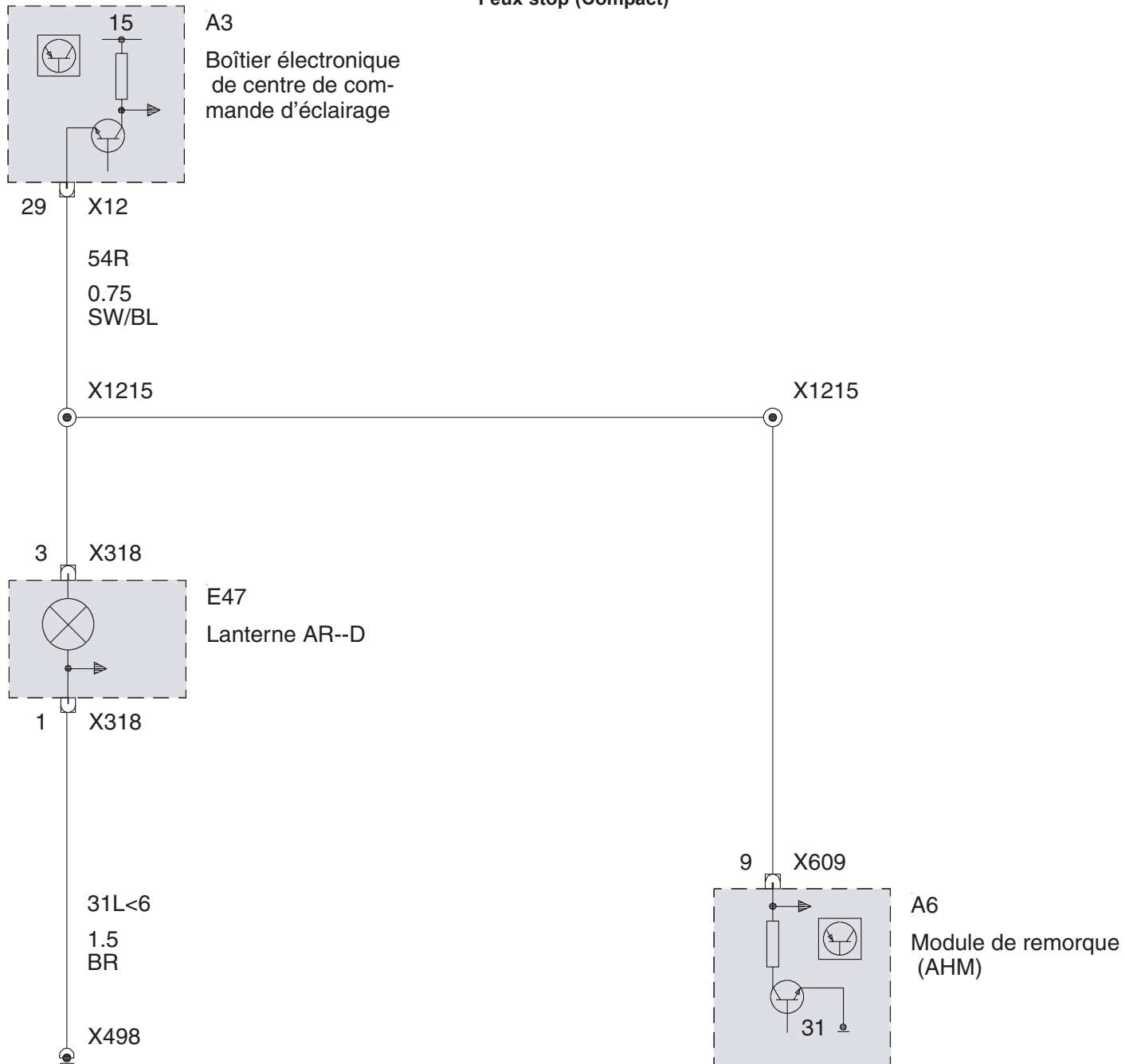

## Clignotants à gauche (Berline)

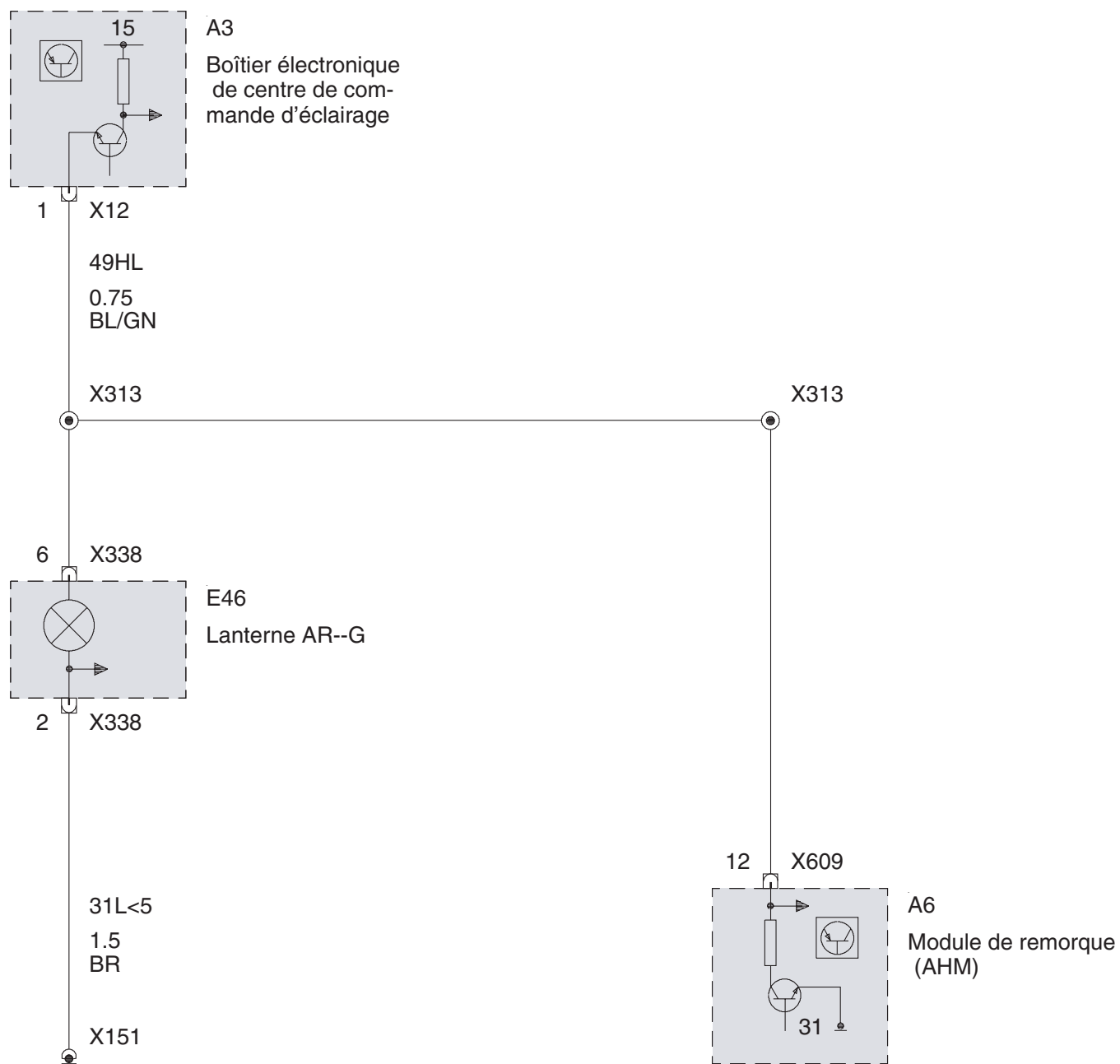

## Clignotants à gauche (Touring)

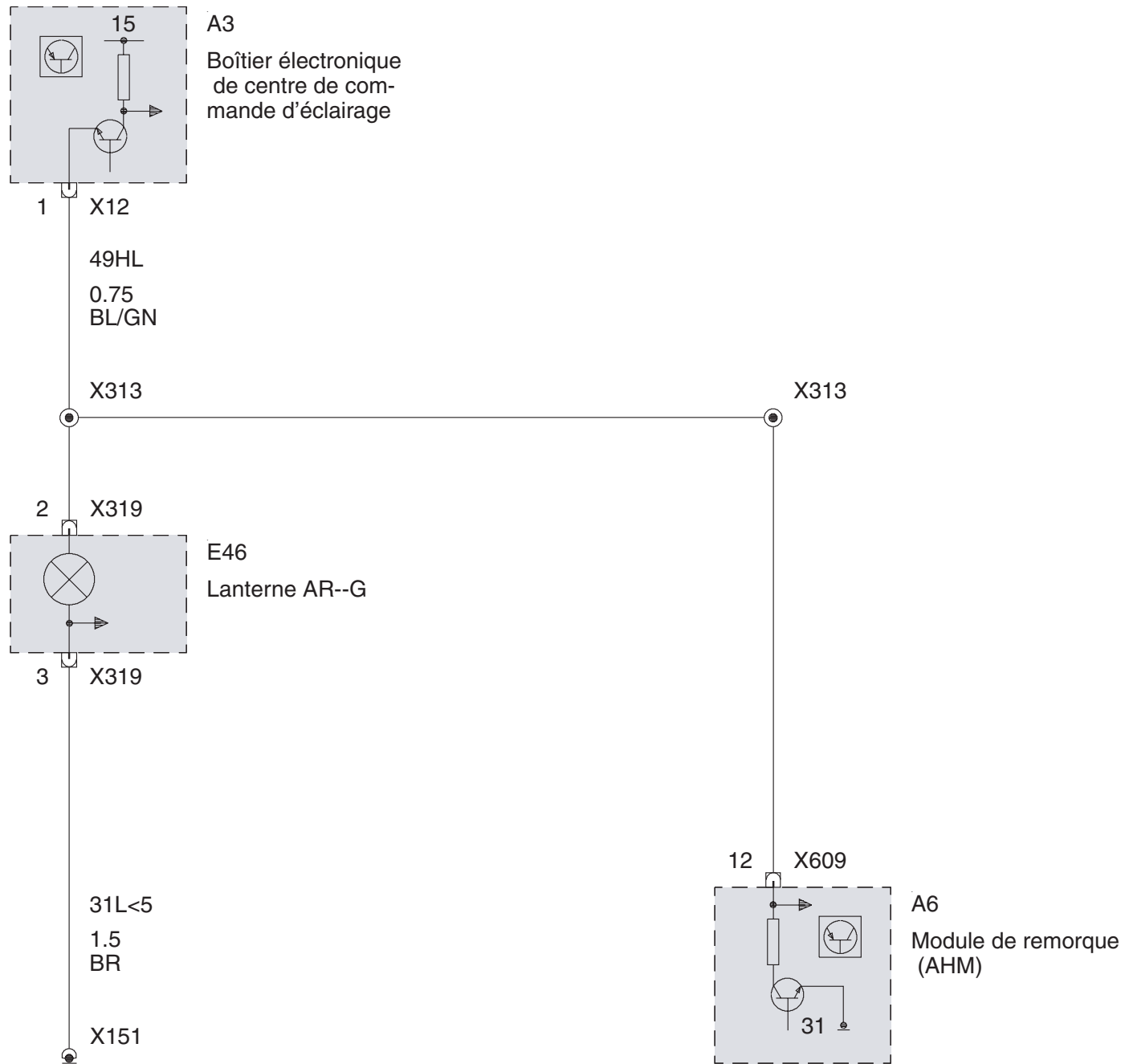

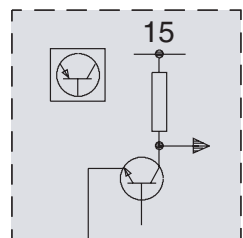

A3 Clignotants à gauche (Coupé ou Cabriolet)

Boîtier électronique  
de centre de commande  
d'éclairage

1 X12  
49HL  
0.75  
BL/GN

X313

5 X319

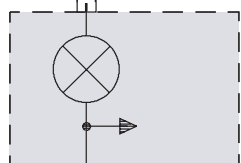

E46  
Lanterne AR--G

4 X319

31L<5  
1.5  
BR

X151

X313

12 X609

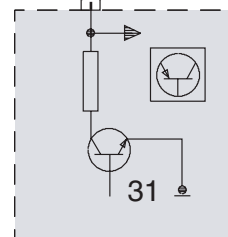

A6  
Module de remorque  
(AHM)

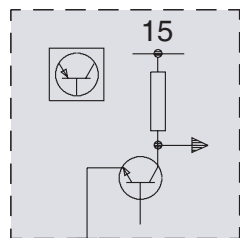

**A3 Clignotants à gauche (Compact)**

Boîtier électronique  
de centre de com-  
mande d'éclairage

1 X12

49HL  
0.75  
BL/GN

X313

2 X319

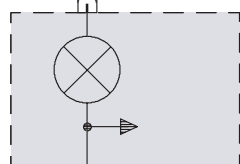

**E46**  
Lanterne AR--G

1 X319

31L<3  
1.5  
BR

X173

X313

12 X609

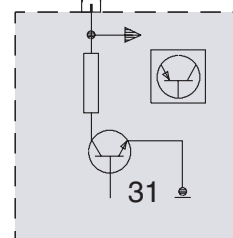

**A6**  
Module de remorque  
(AHM)

31

## Clignotants à droite (Berline)

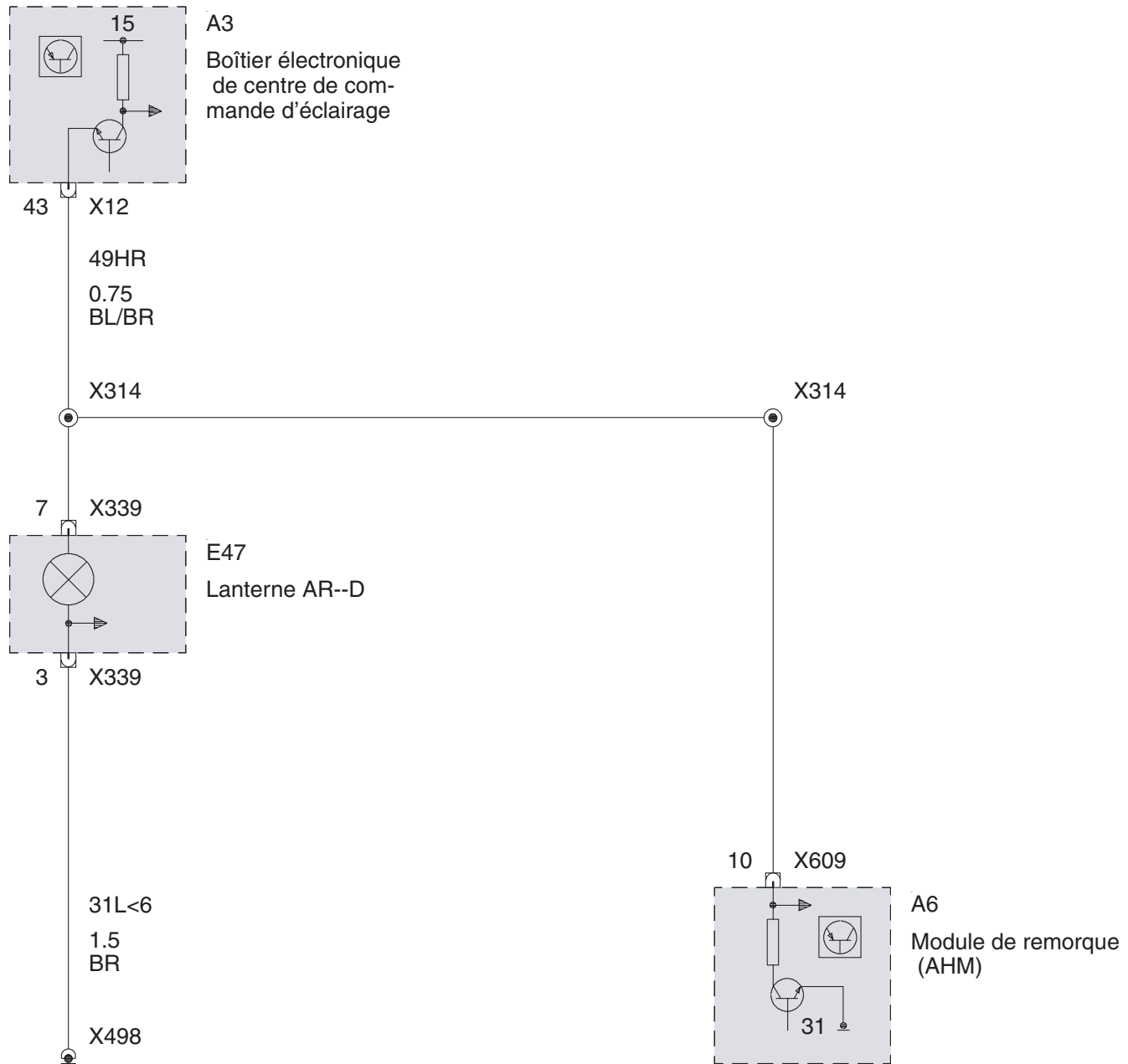

## Clignotants à droite (Touring)

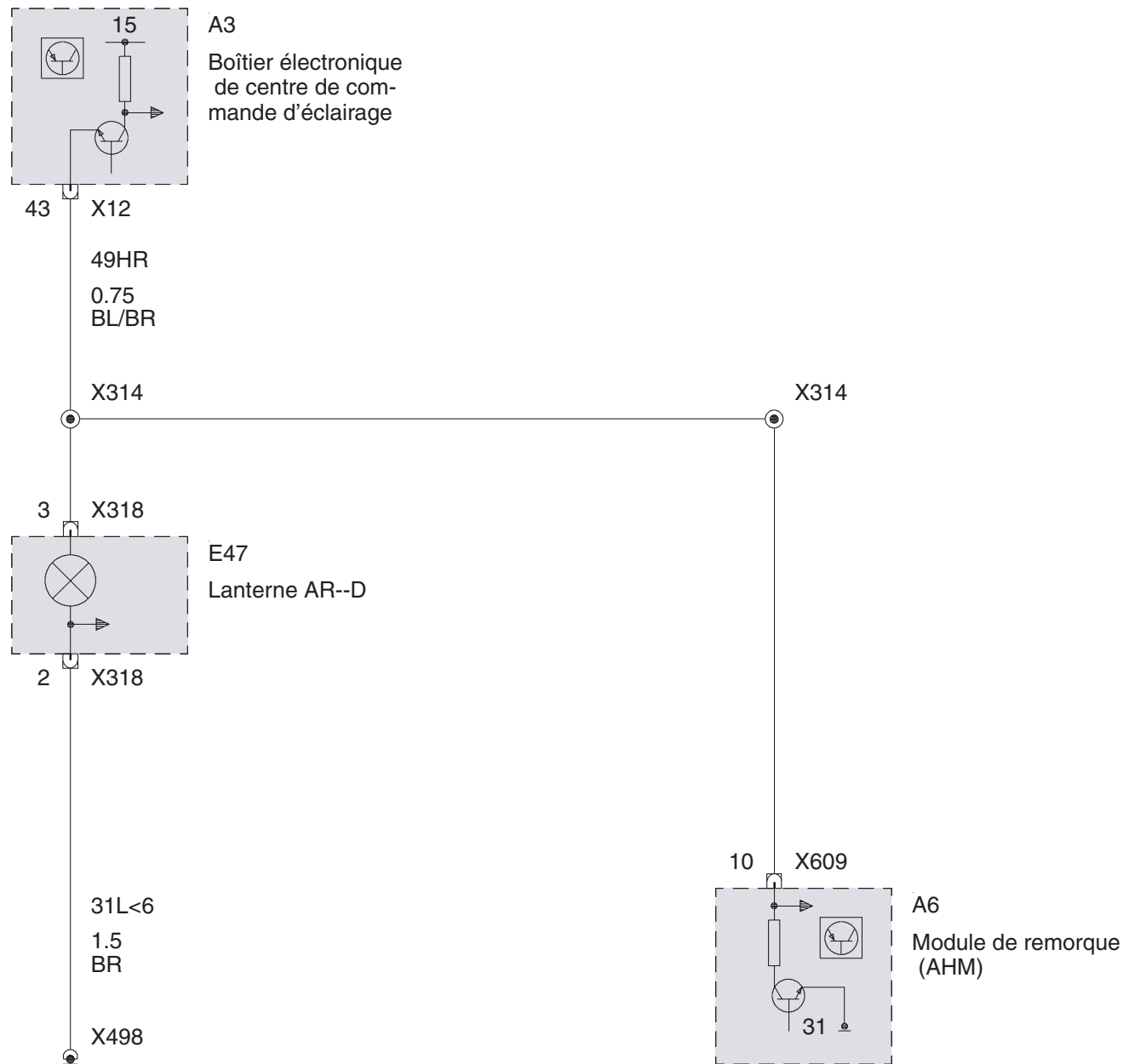



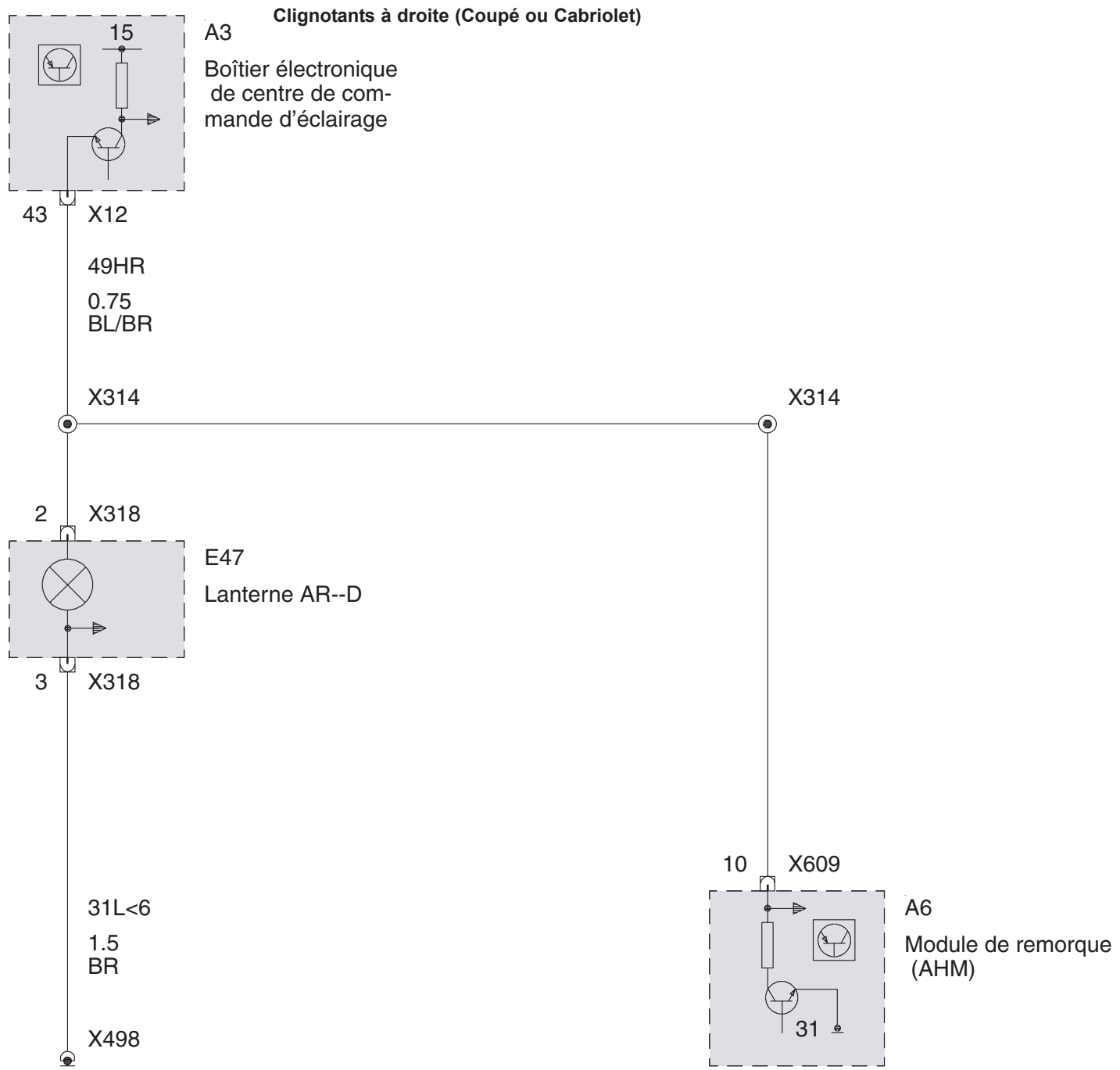

## Clignotants à droite (Compact)

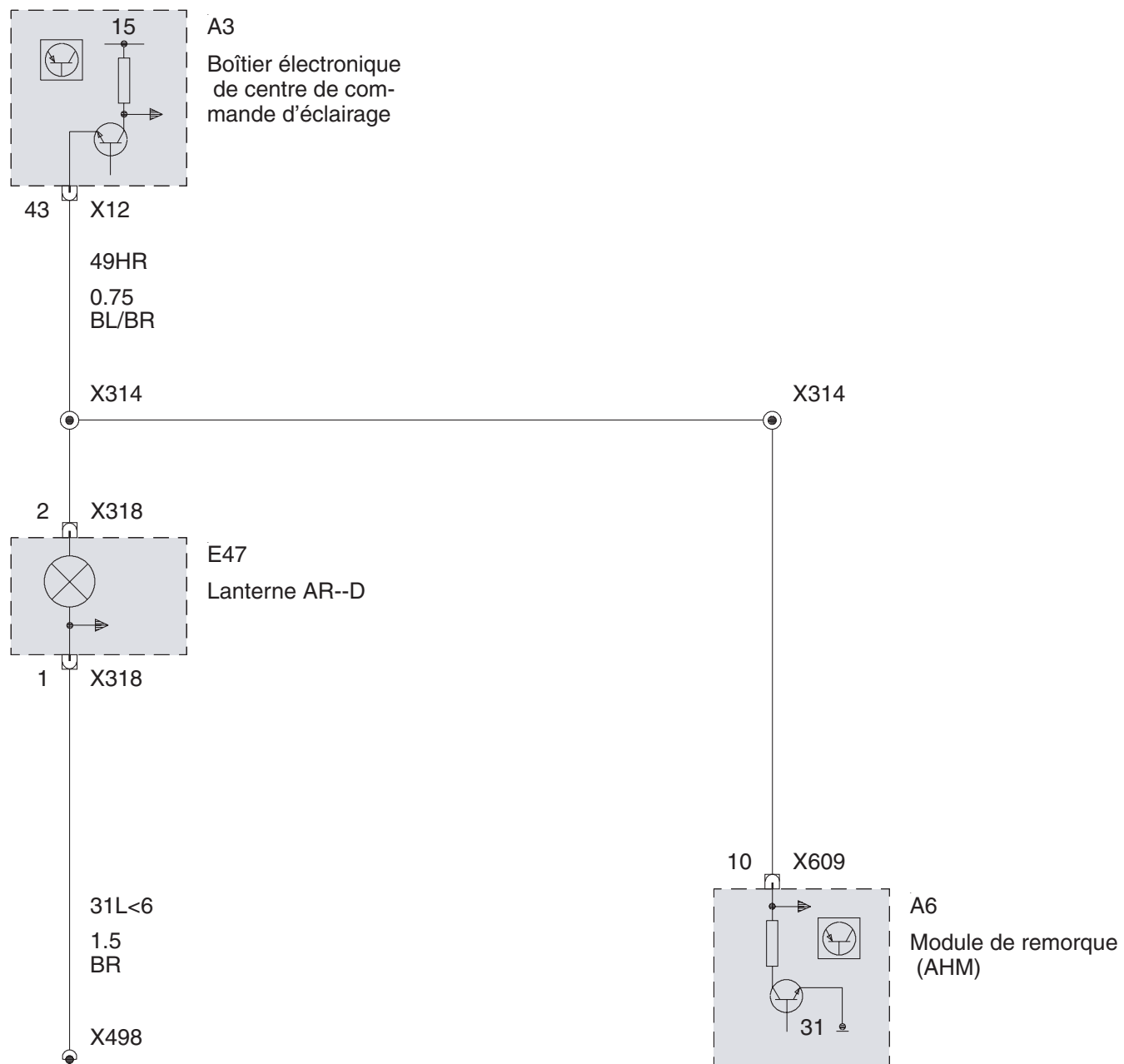

### Eclairage habitacle Eclairage intérieur/habitacle (Berline ou Coupé ou Compact)

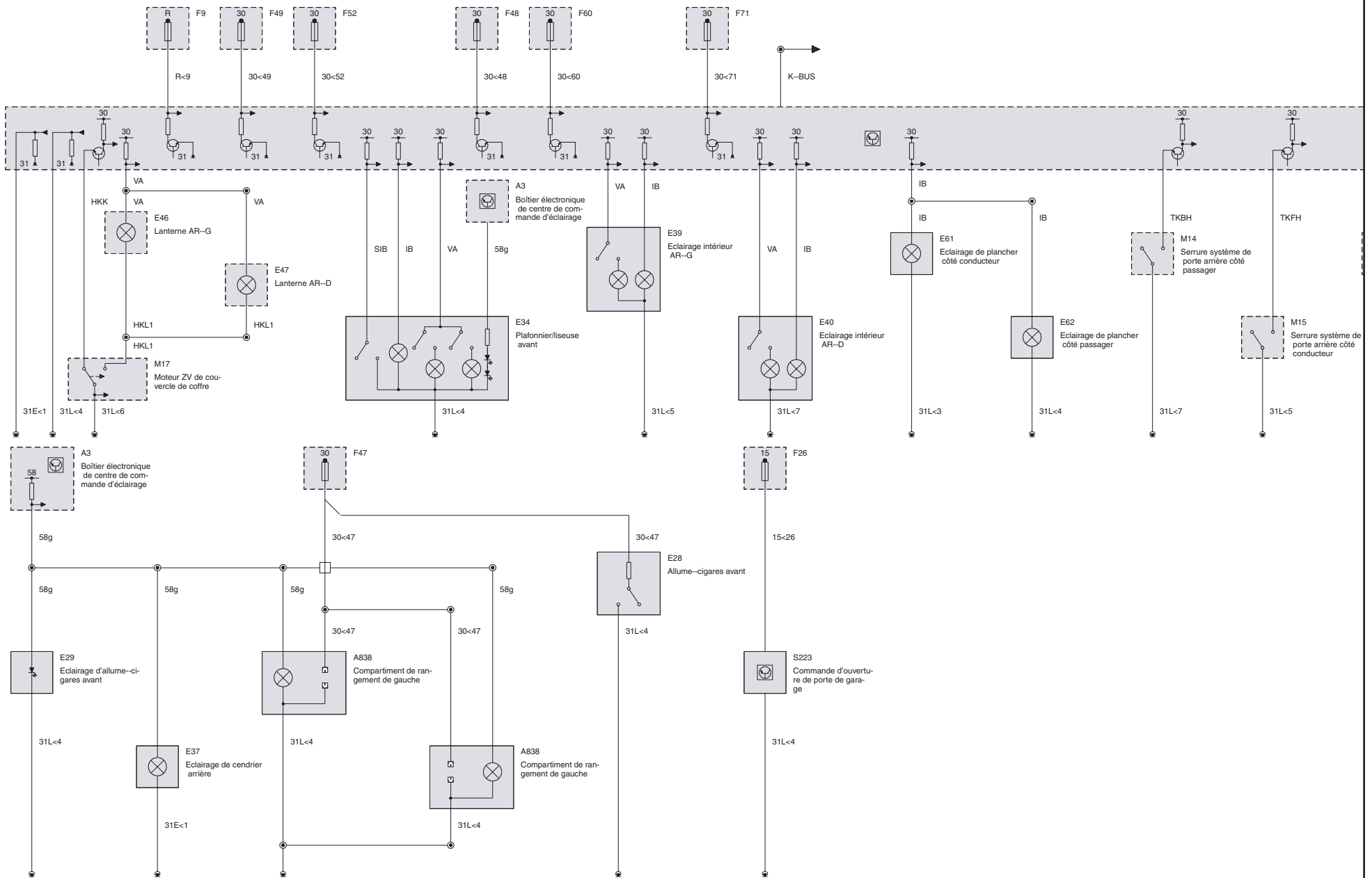

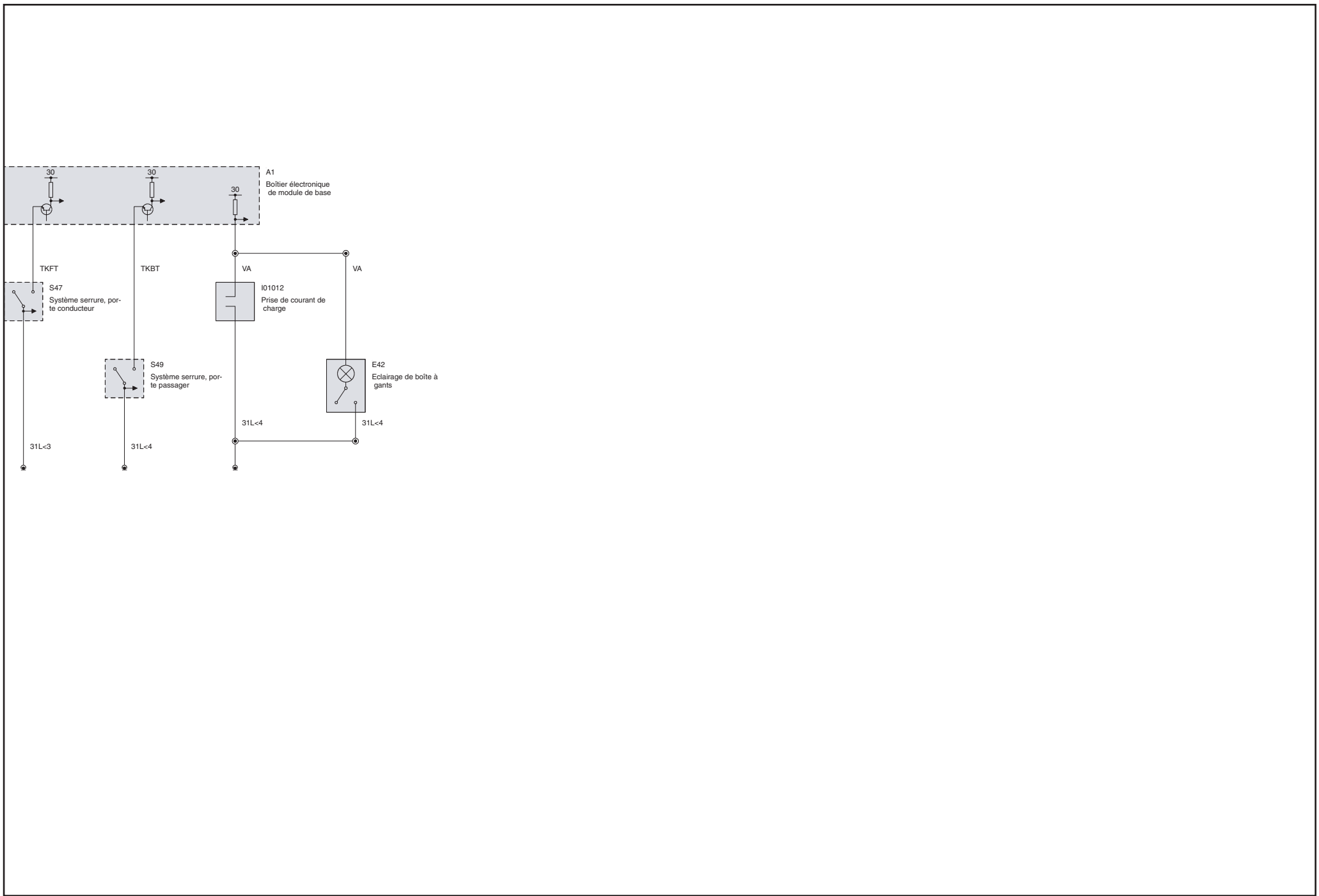

Eclairage intérieur/habitacle (Touring)

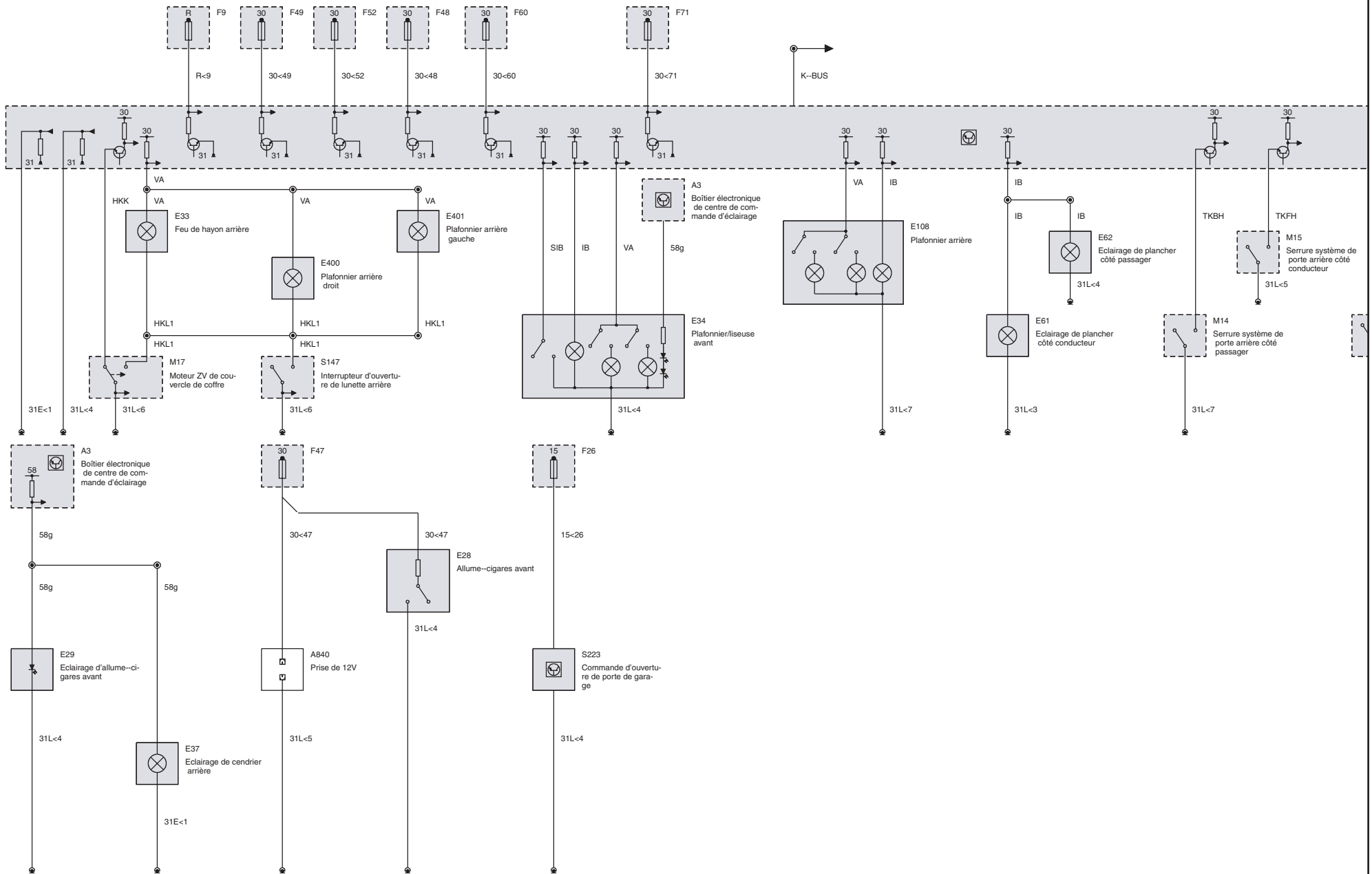

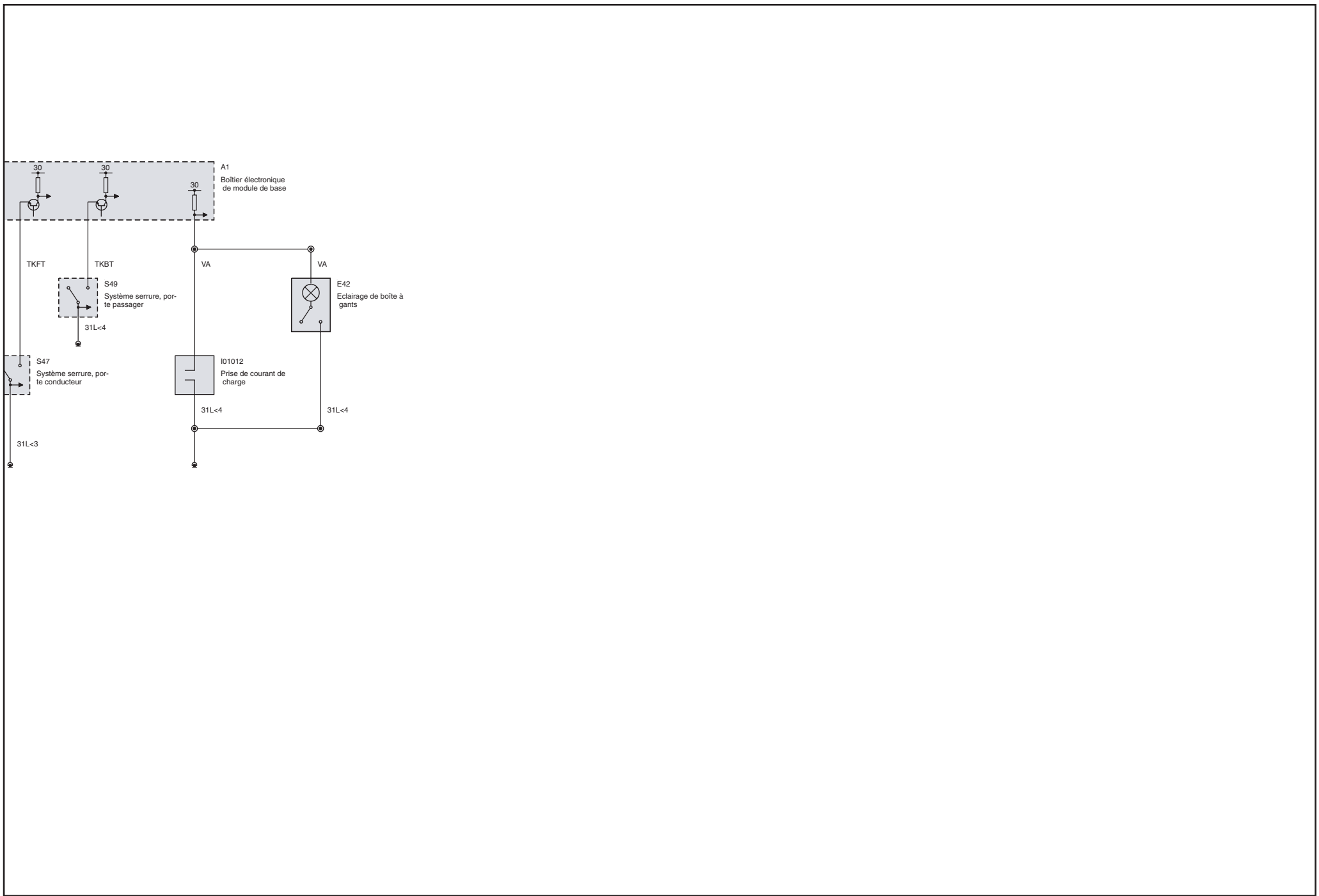

Eclairage compartiment rangement (Option Double-fourre-tout)

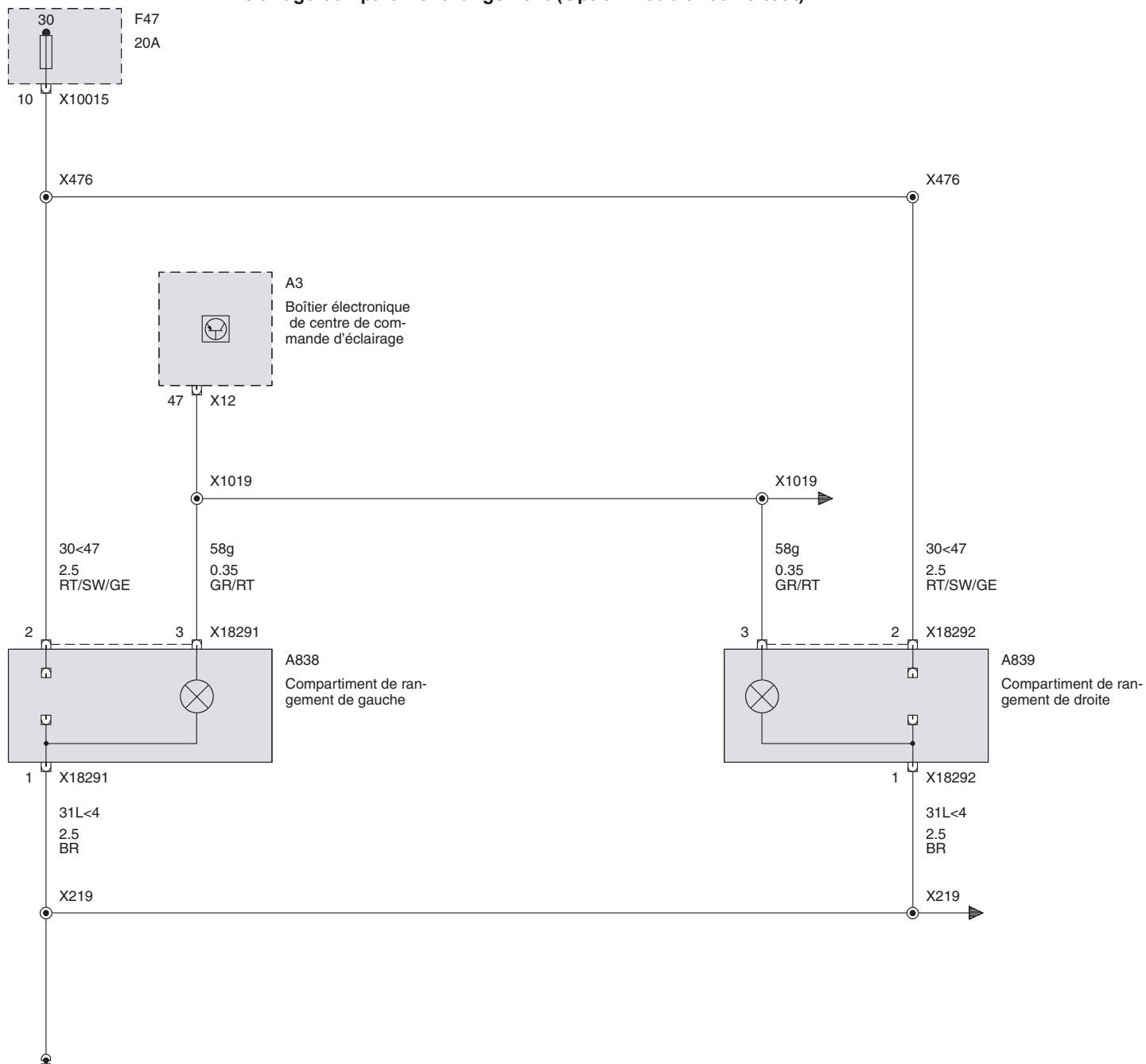

Eclairage intérieur avant

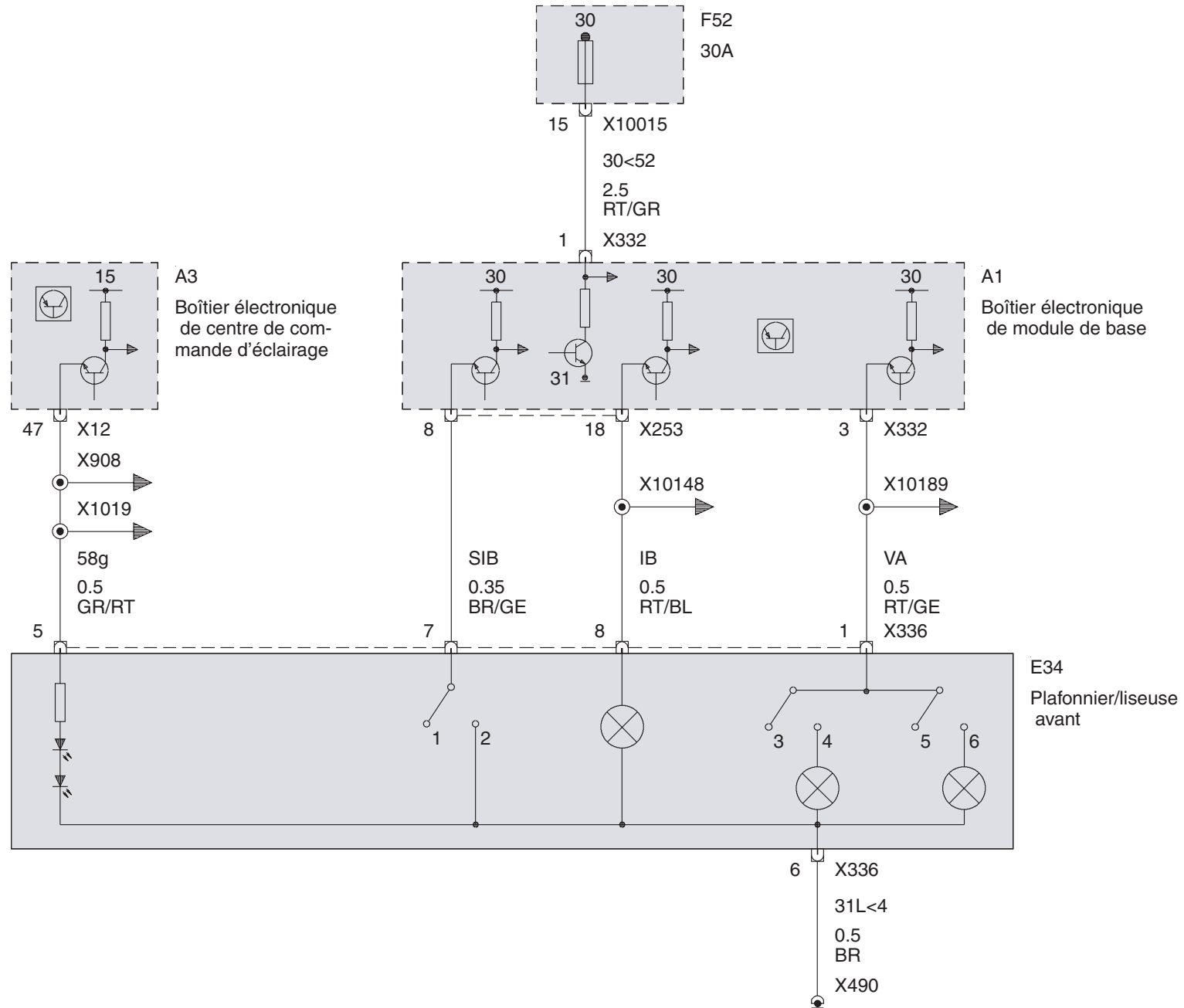



## Eclairage intérieur Ar-G (sauf Touring et Cabriolet)

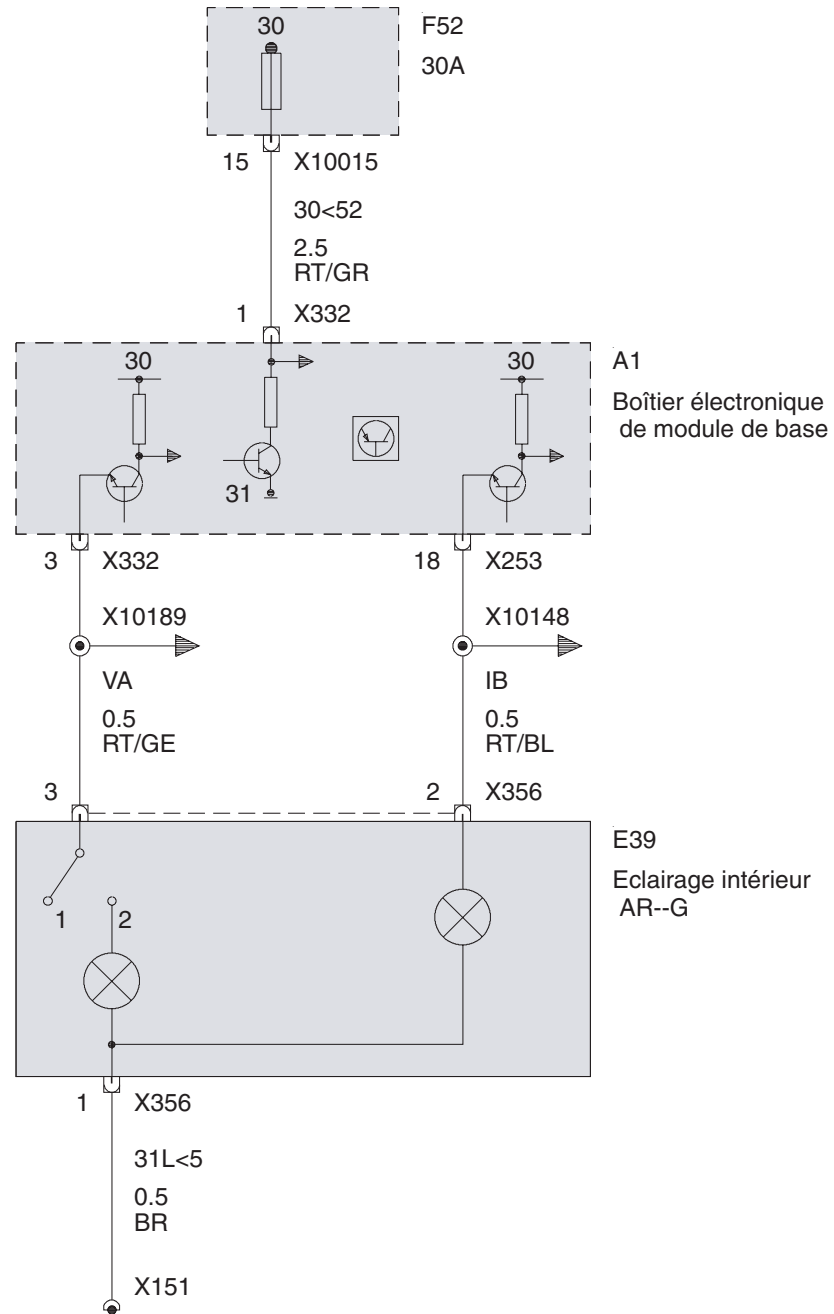

Plafonniers arrière (Touring)

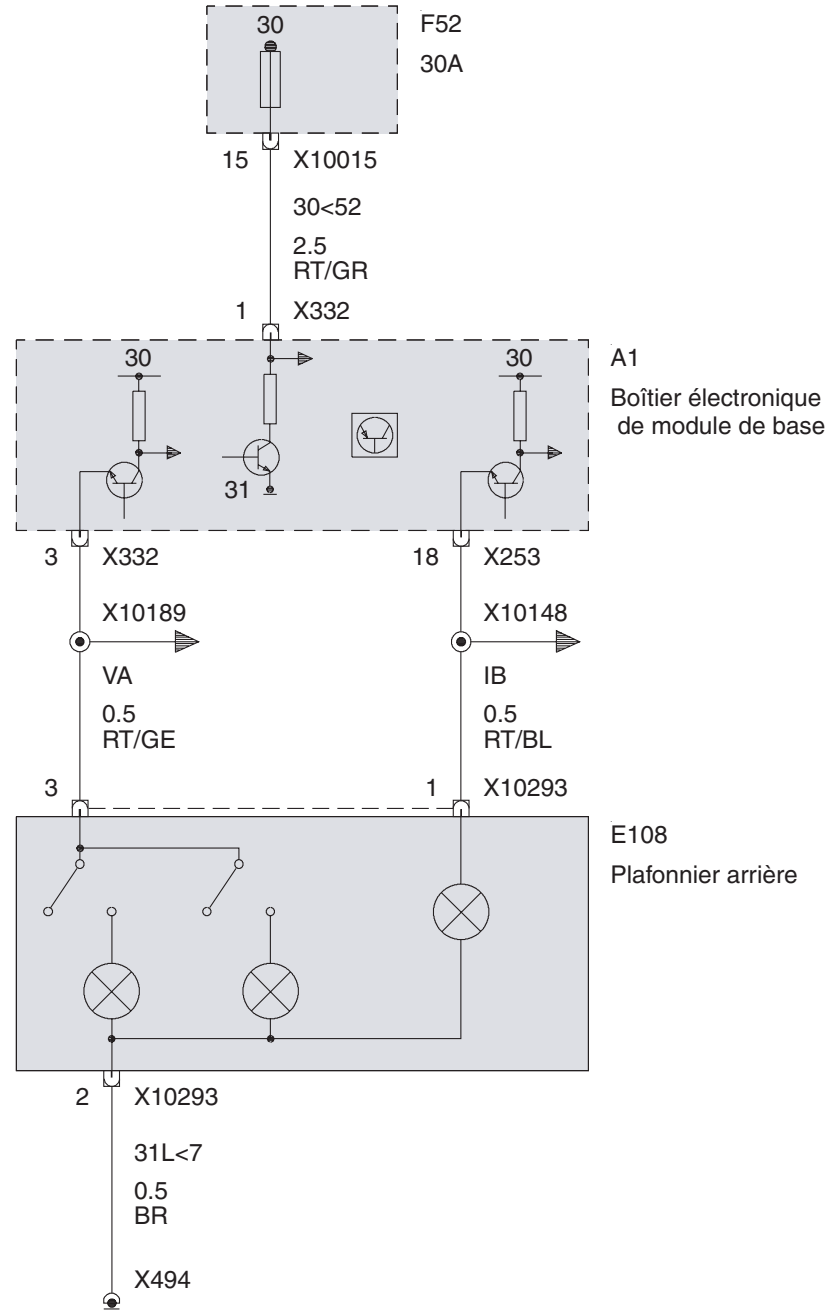

Plafonniers arrière (Compact)

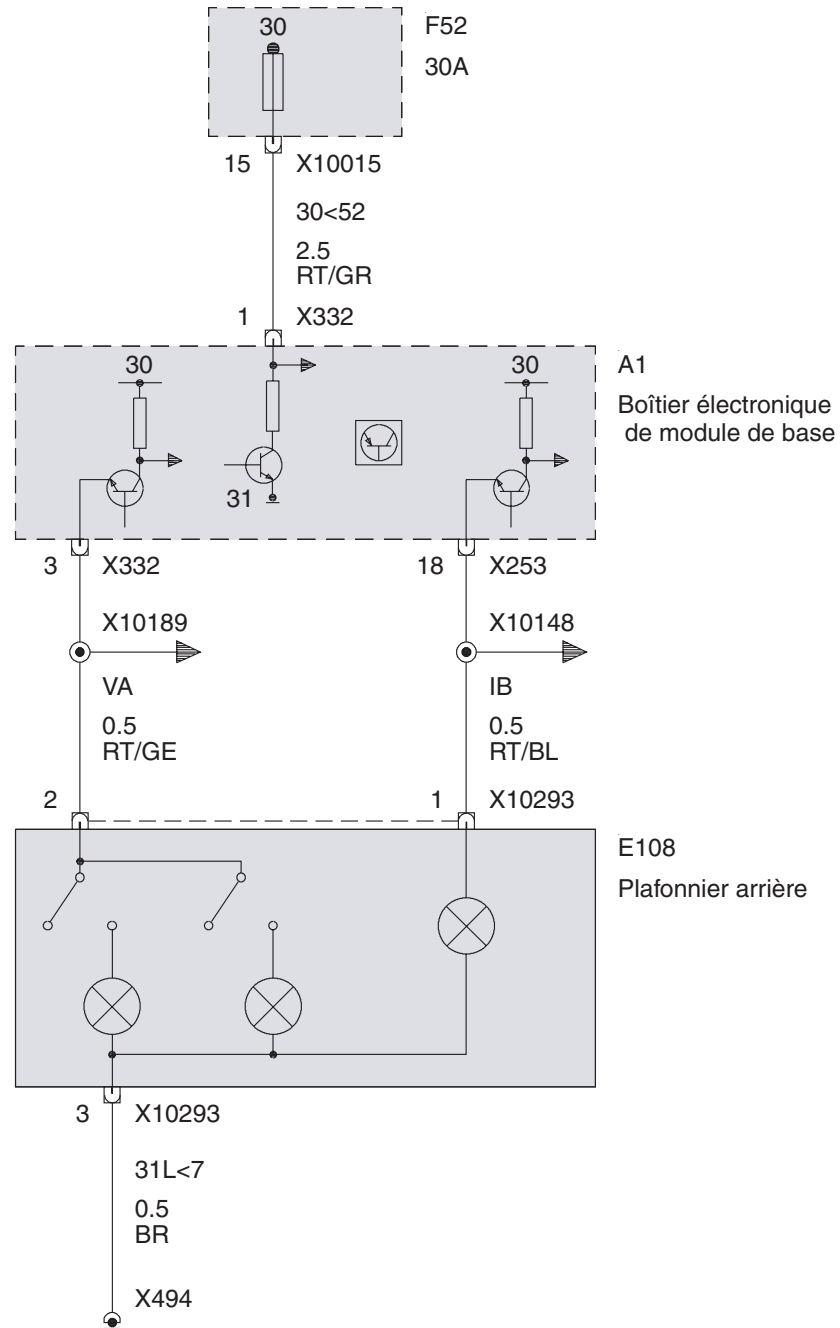

Eclairage intérieur Ar-D (sauf Touring et Cabriolet)

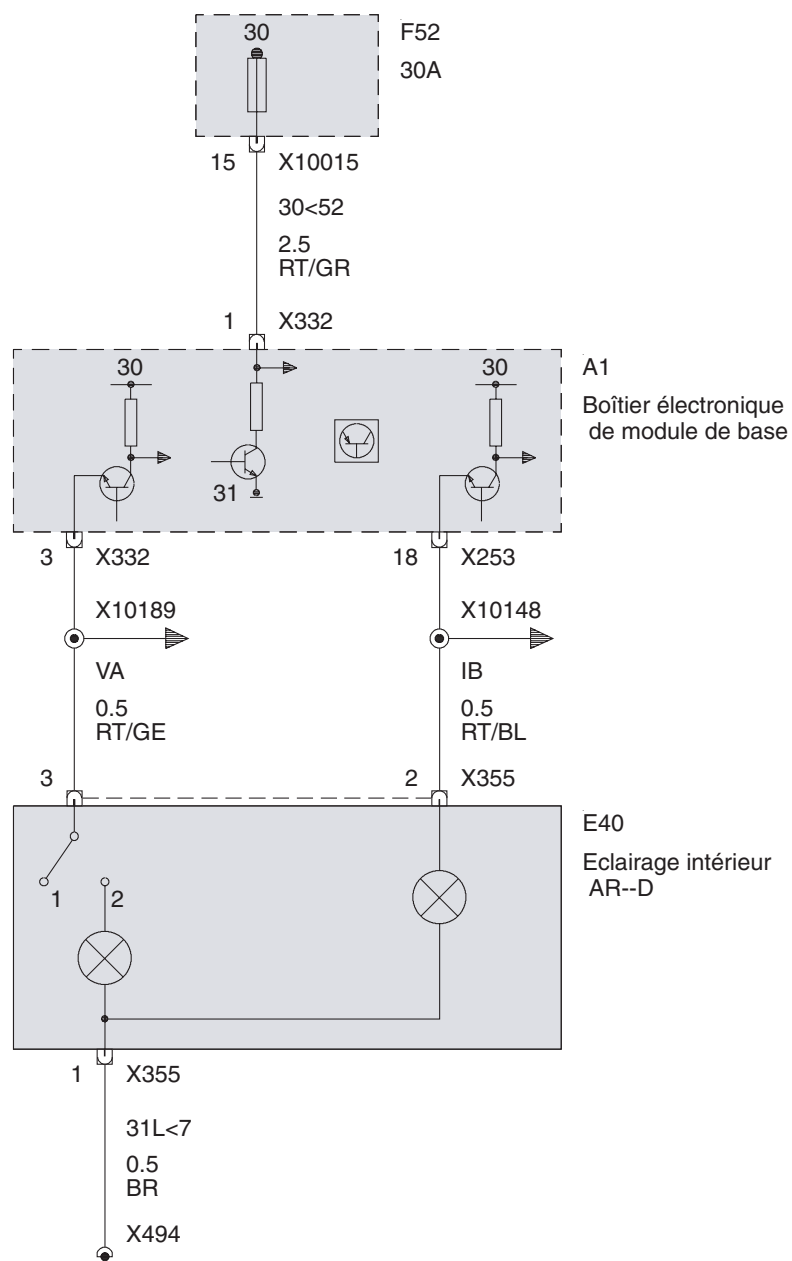

## Lampe de boîte à gants

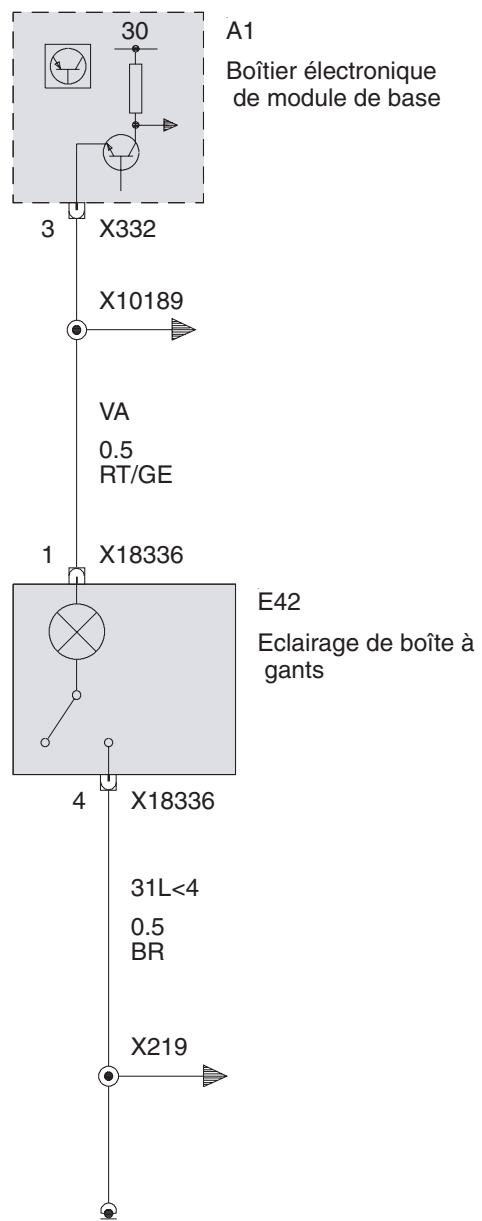

Lampes de bas d'habitacle

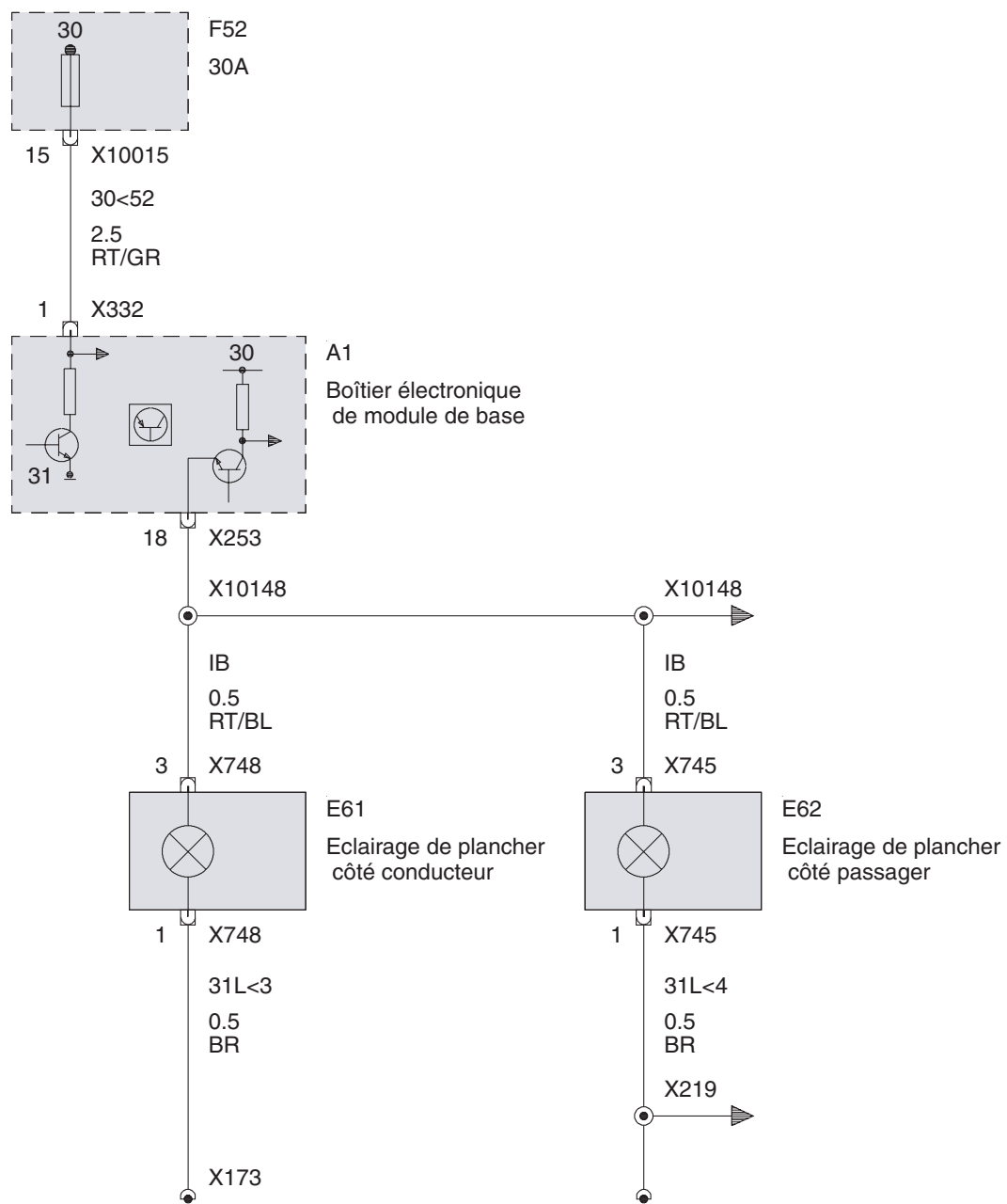

Eclairage coffre à bagages (Compact ou Touring)

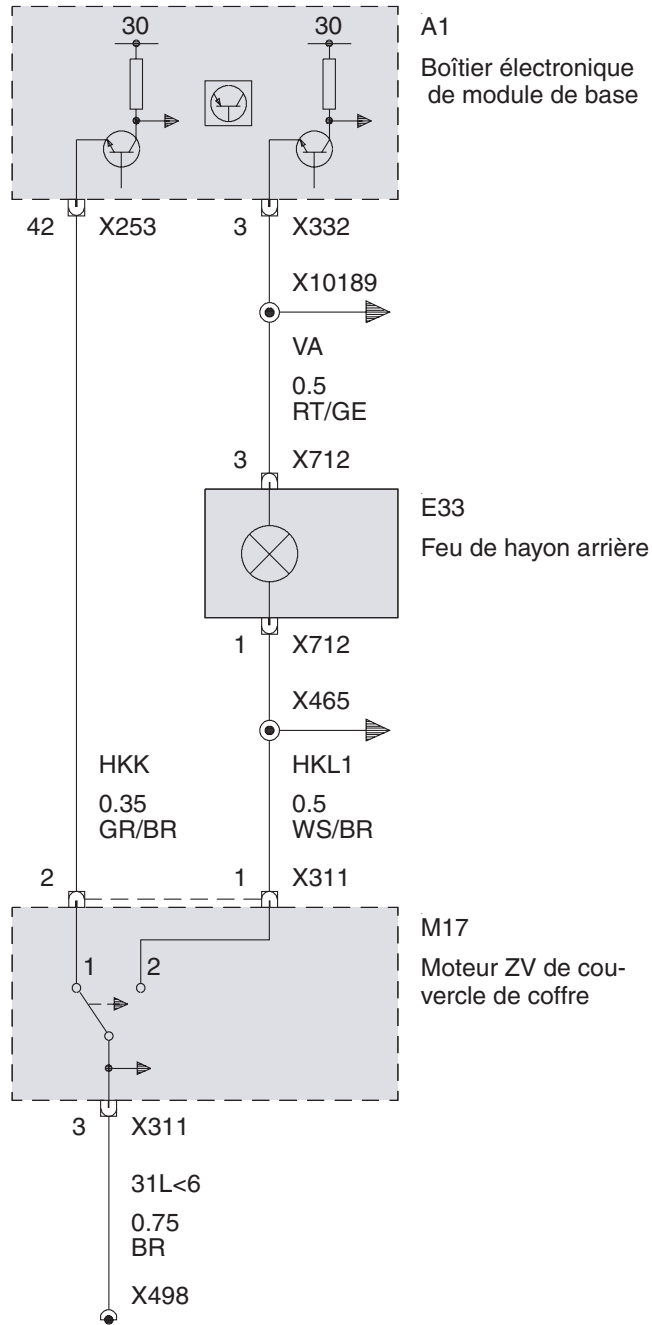

Eclairage coffre à bagages (Coupé ou Cabriolet jusque 2003\_03)

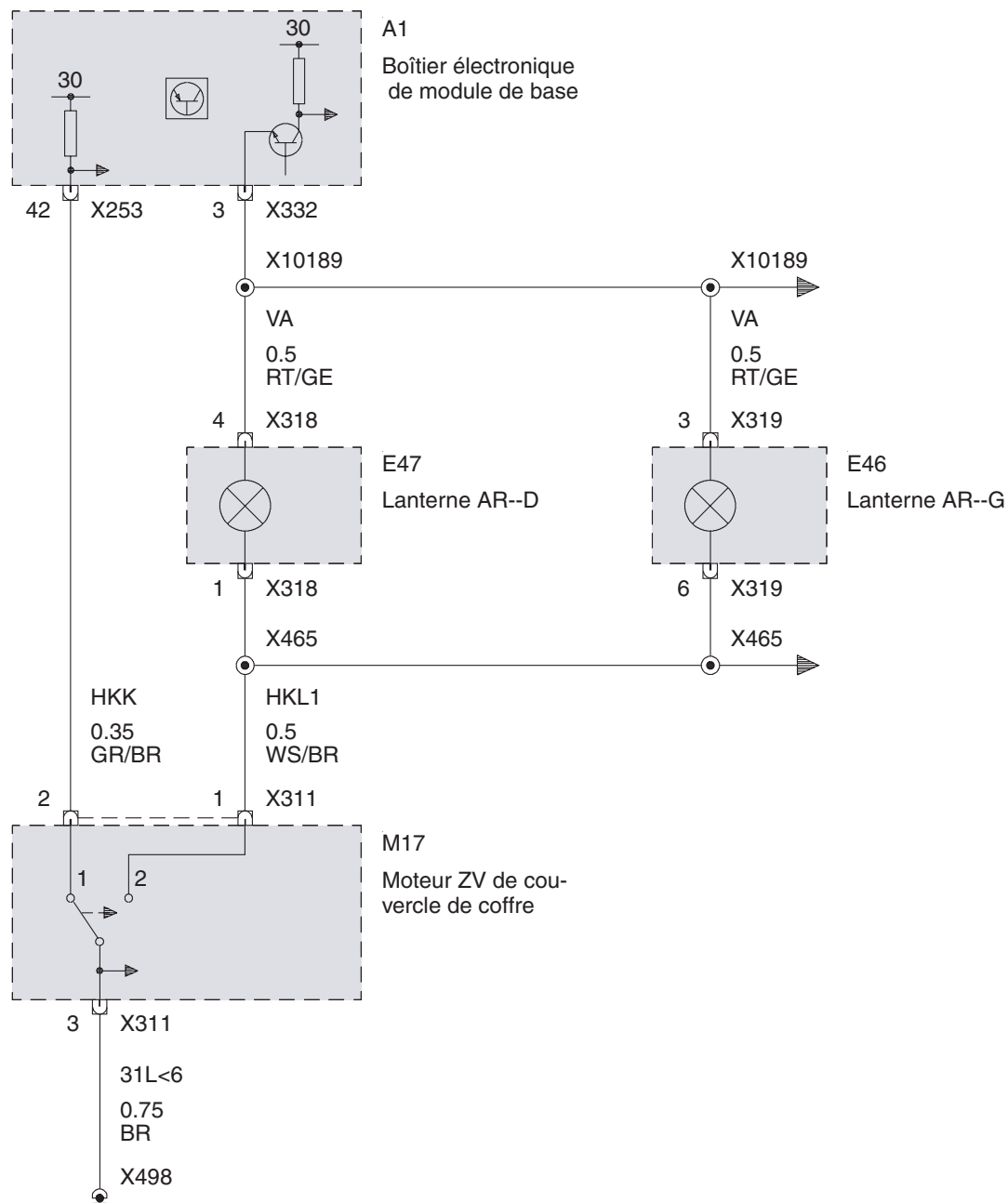



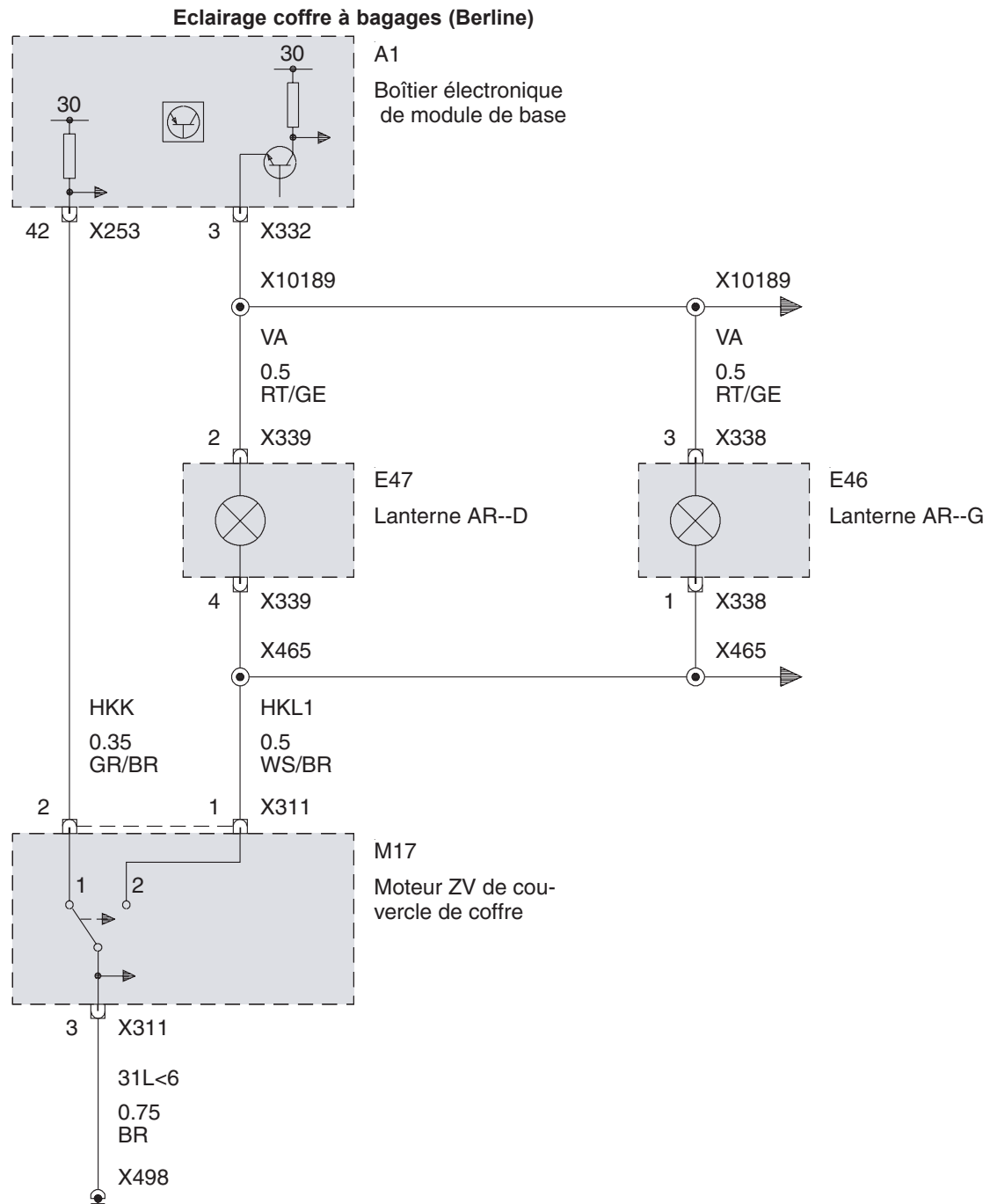

Eclairage coffre à bagages (Coupé ou Cabriolet à partir de 2003\_03)

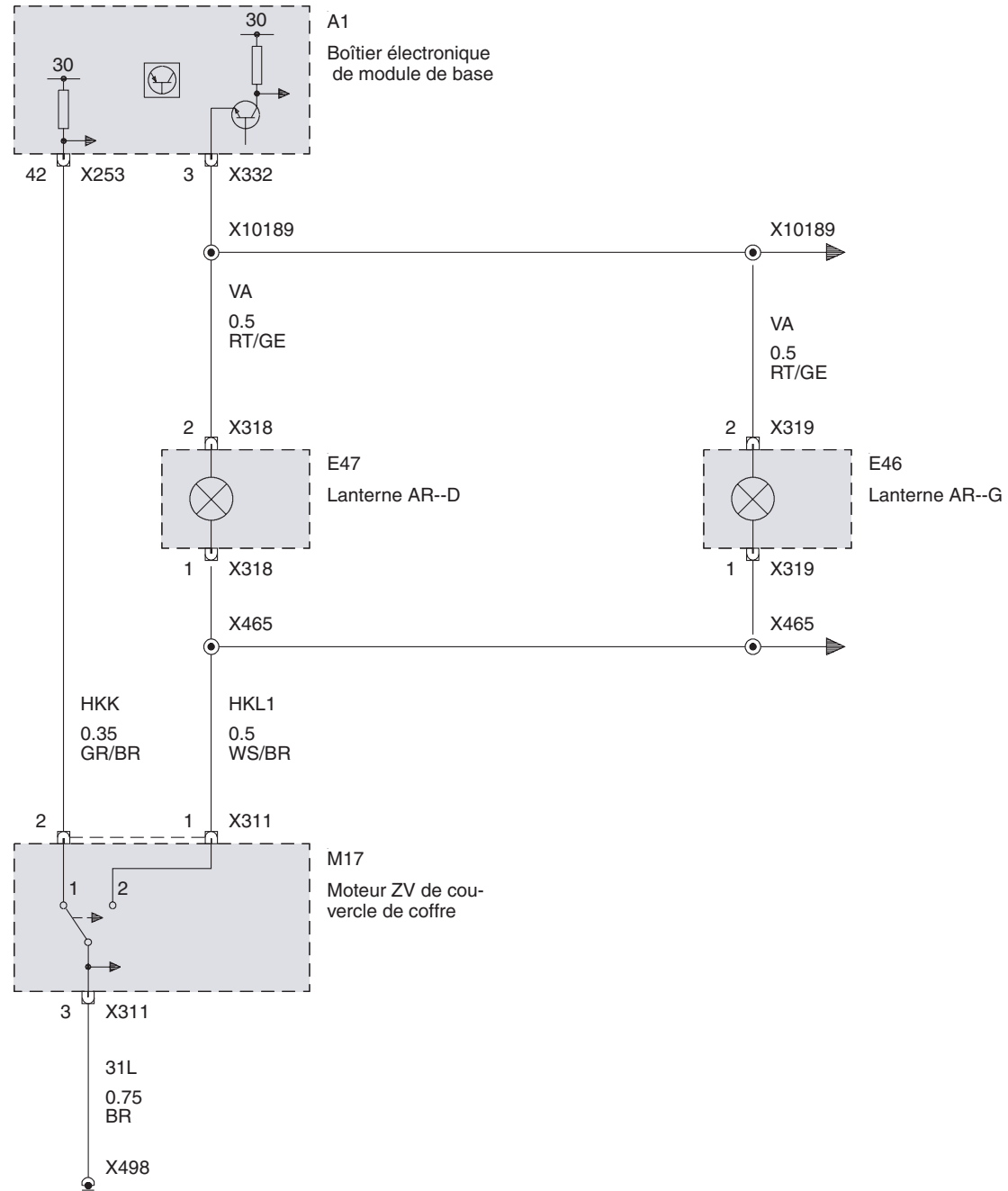

Eclairage de miroir de courtoisie

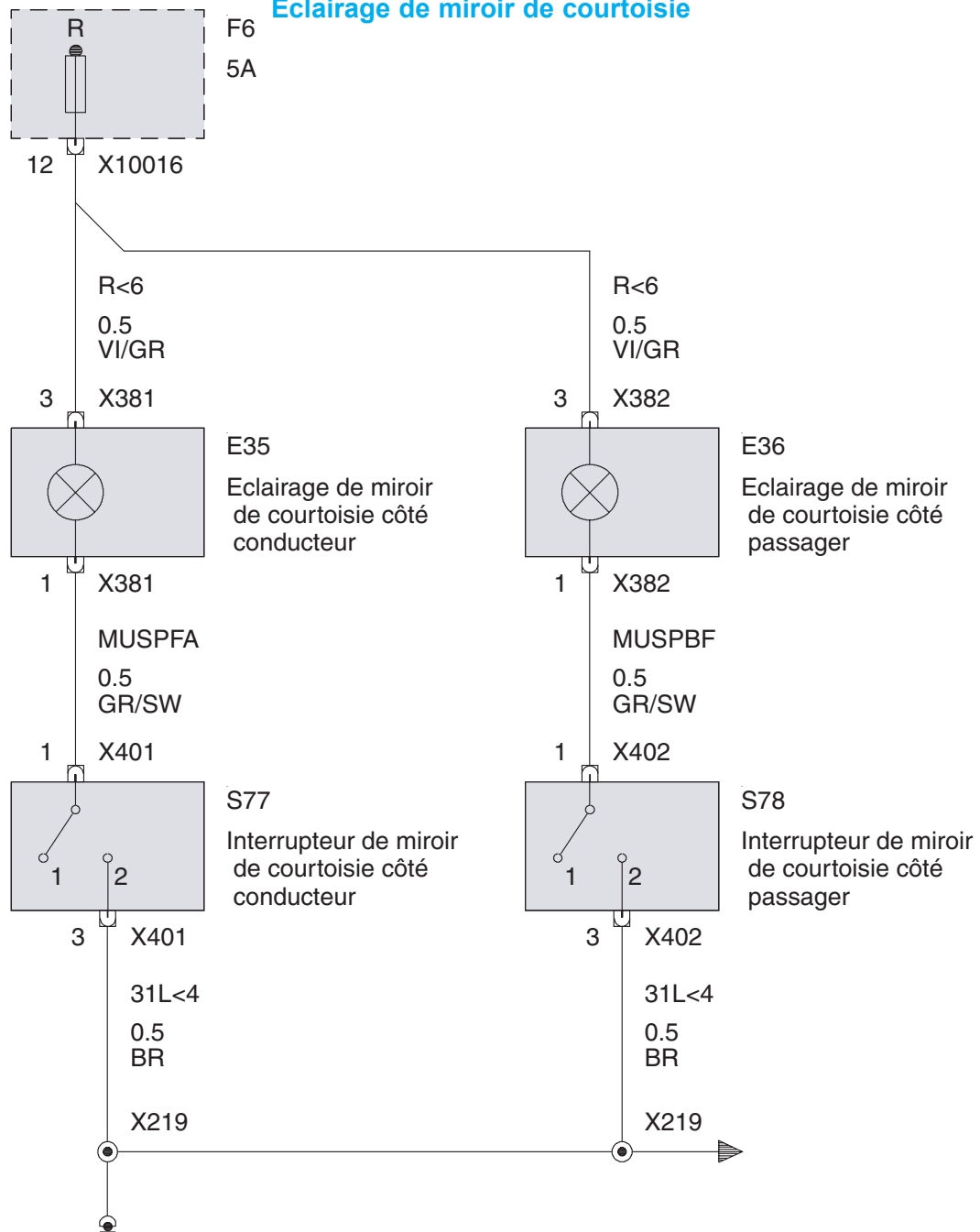

## Rhéostat d'éclairage

Connecteur d'éclairage des instruments et de repérage des commandes X1019 (à partir de 1999\_09 jusque 2003\_03)

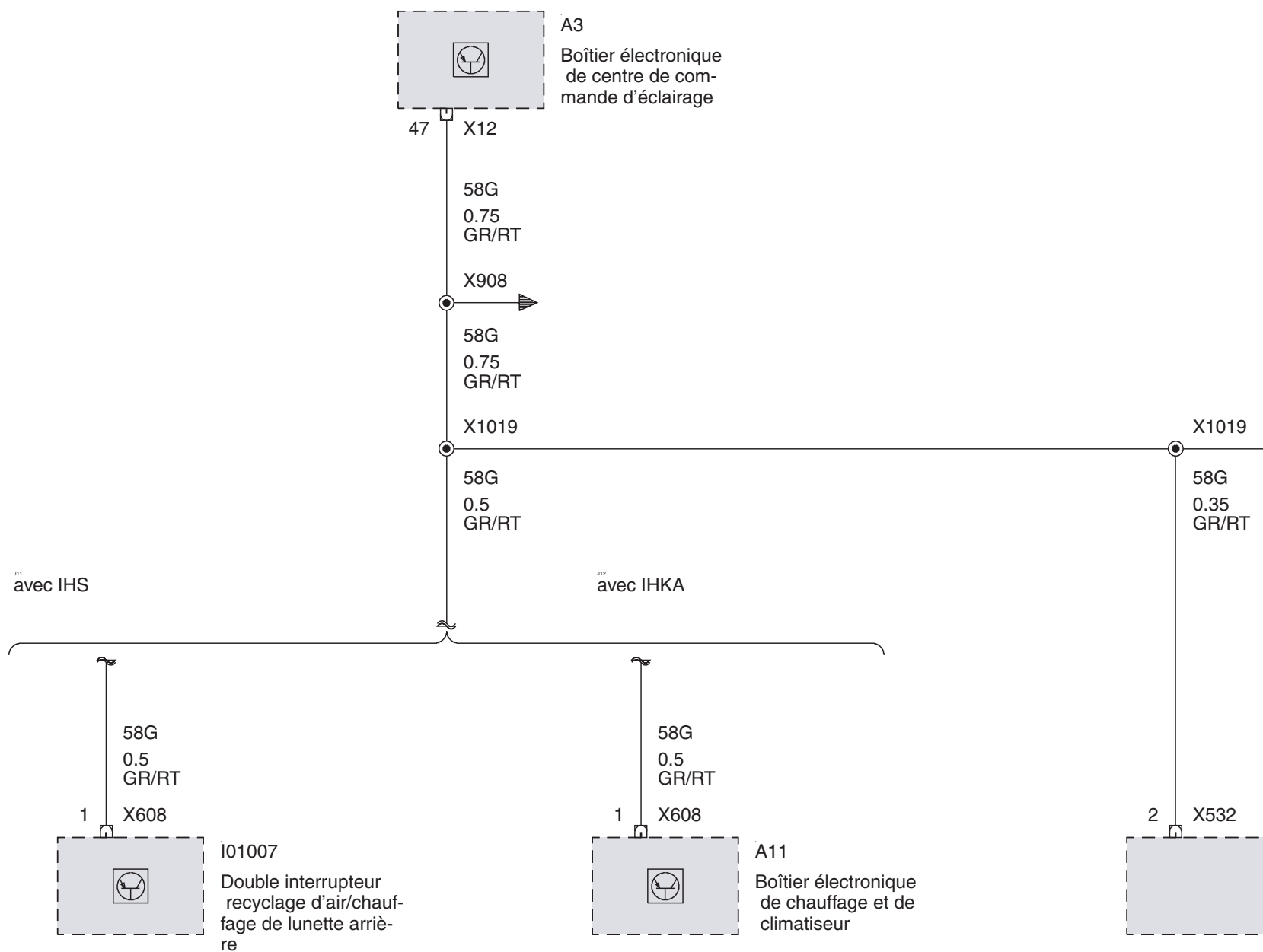

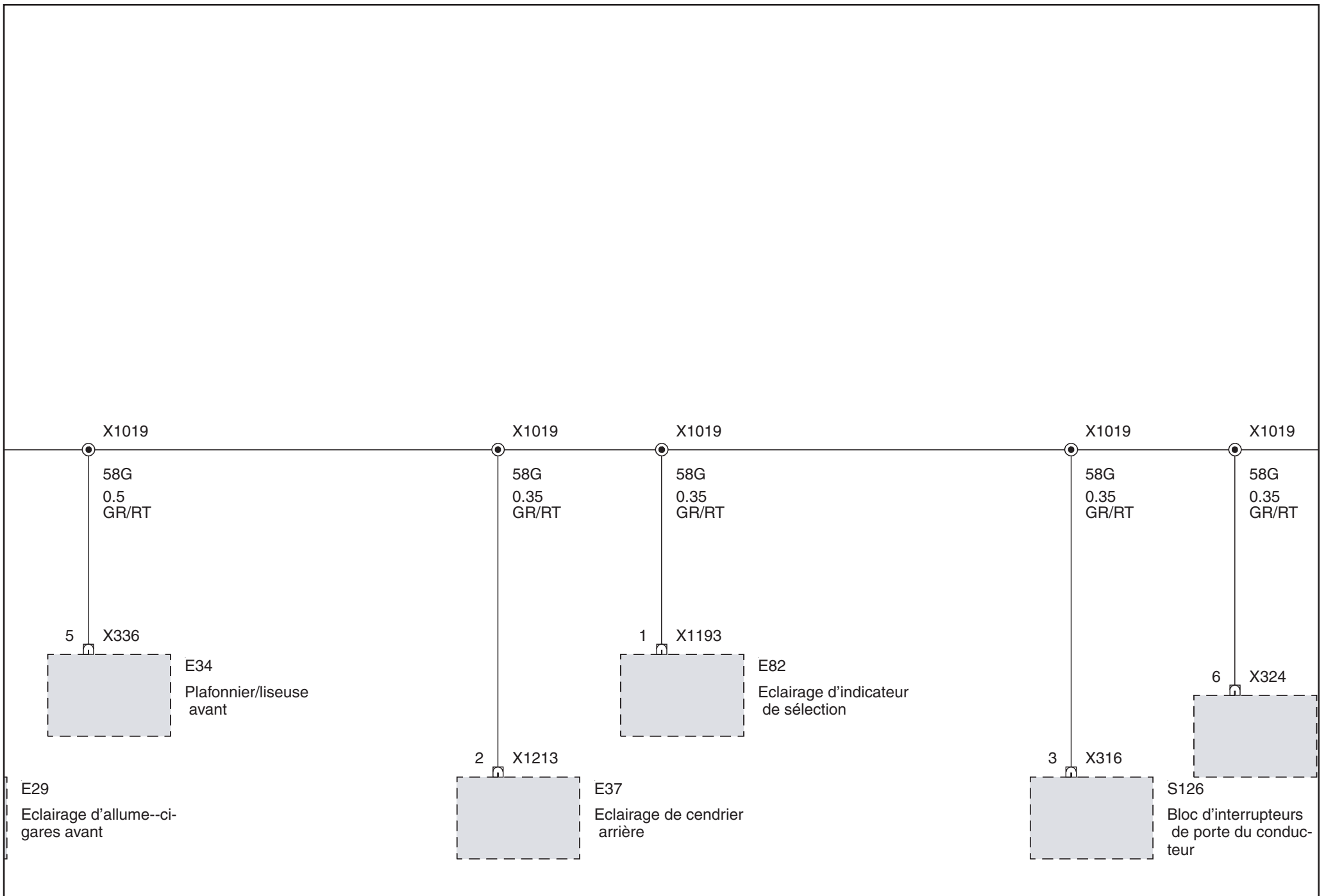

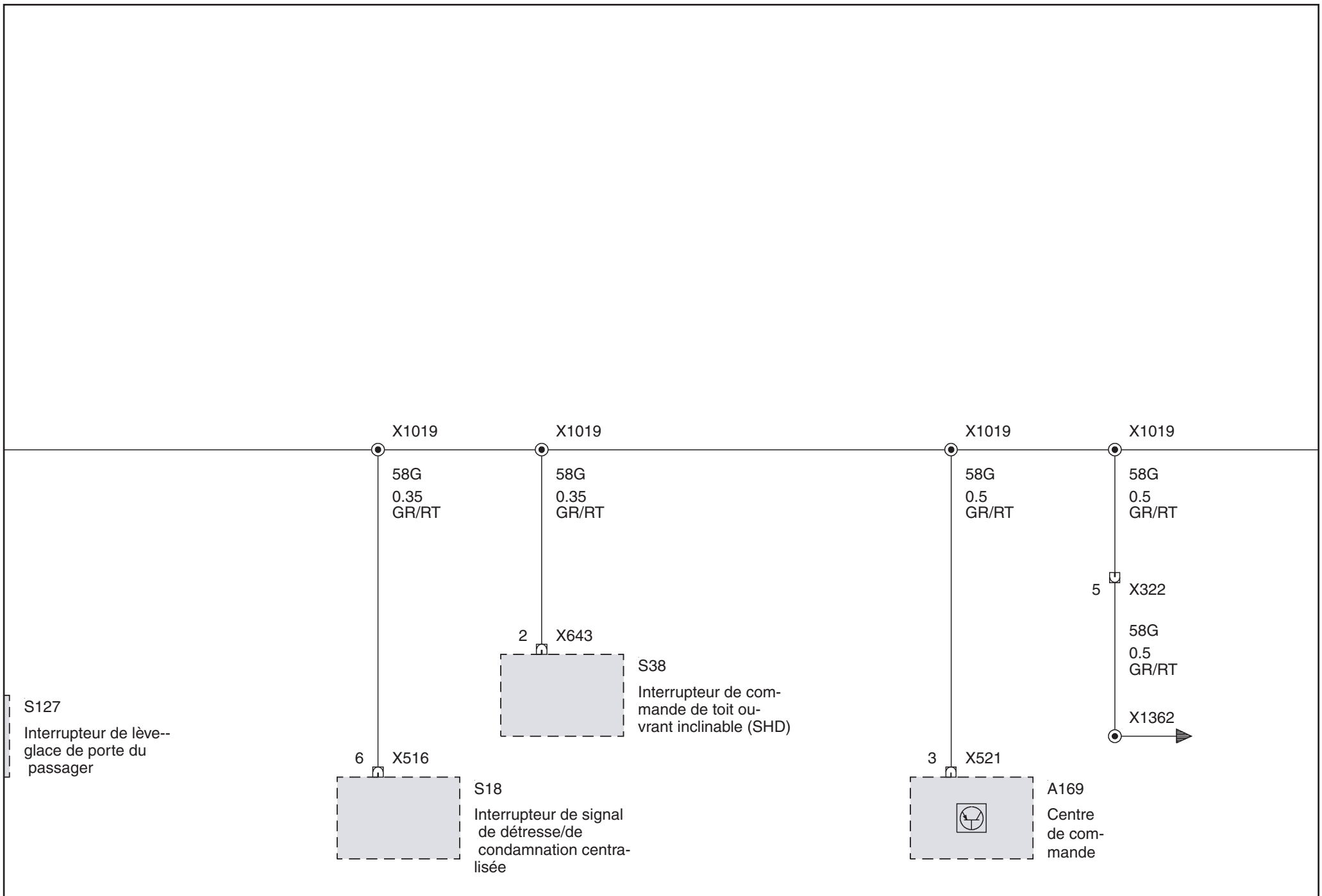

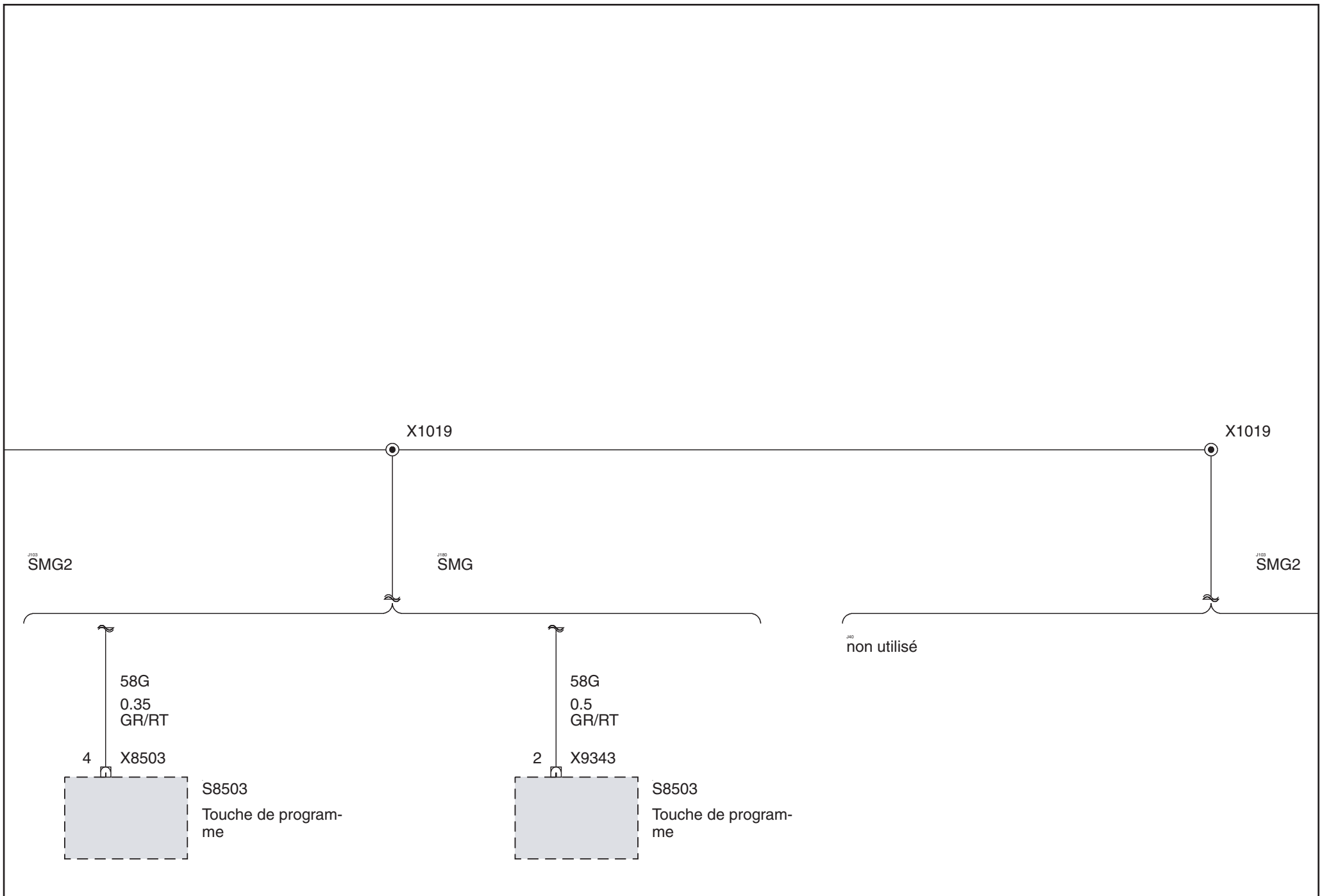

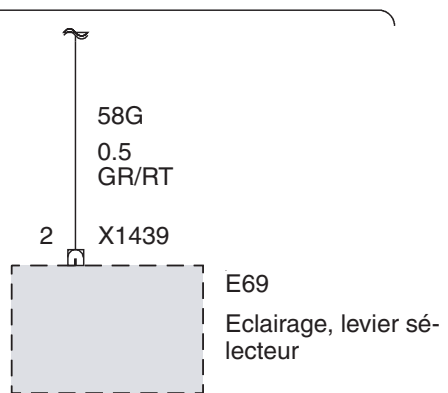



Connecteur d'éclairage des instruments et de repérage des commandes X1019 (à partir de 2003\_03)

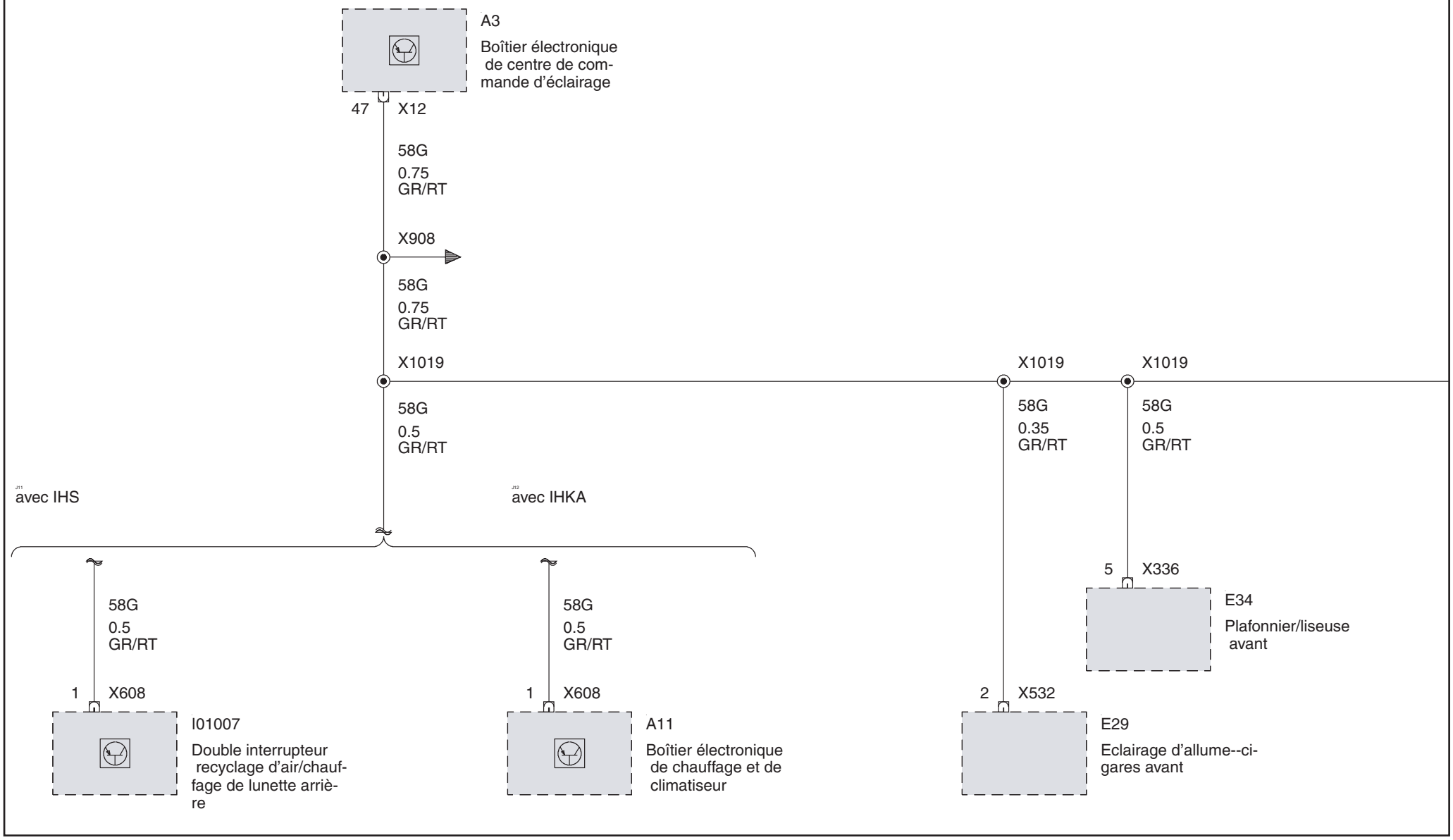

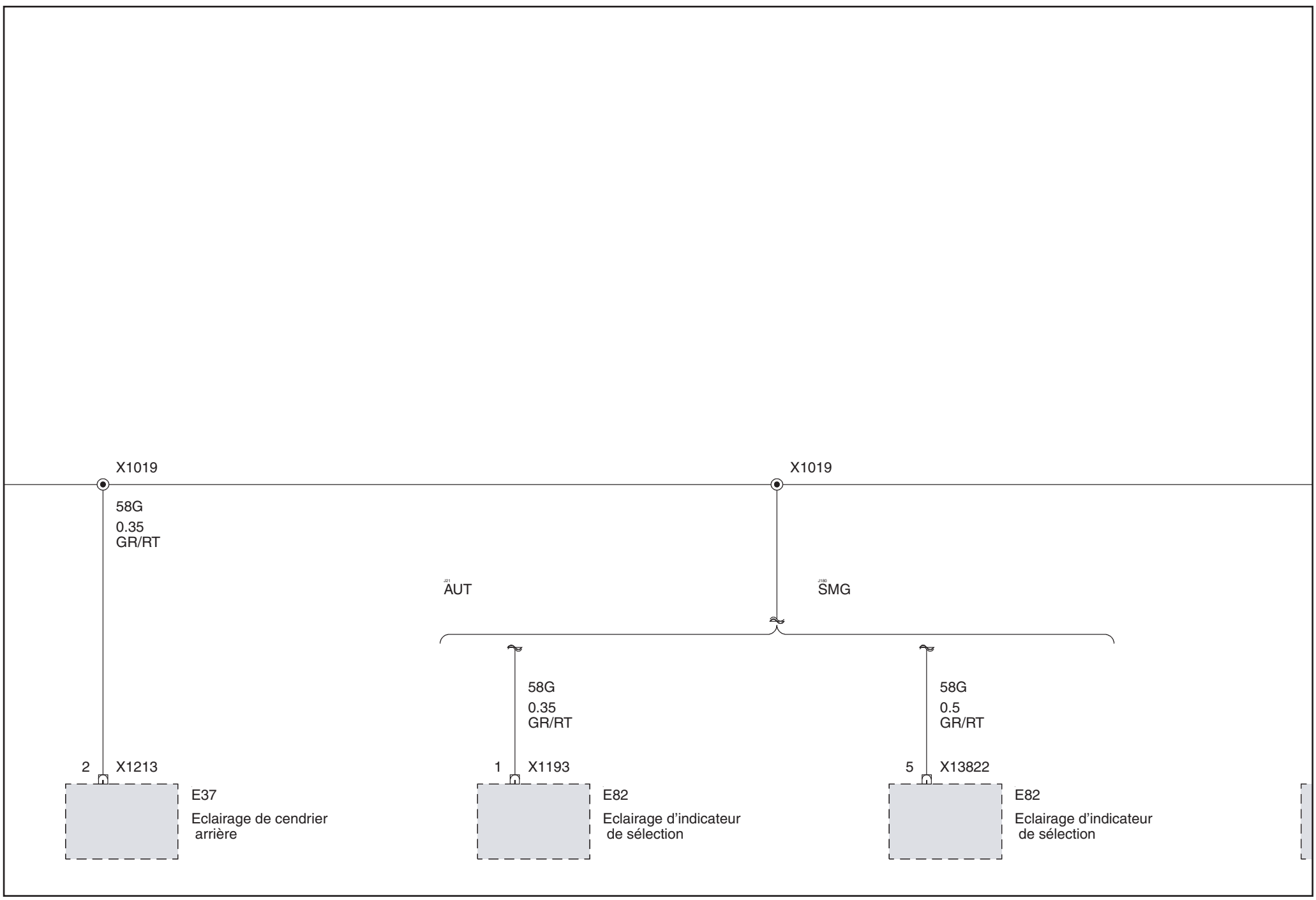

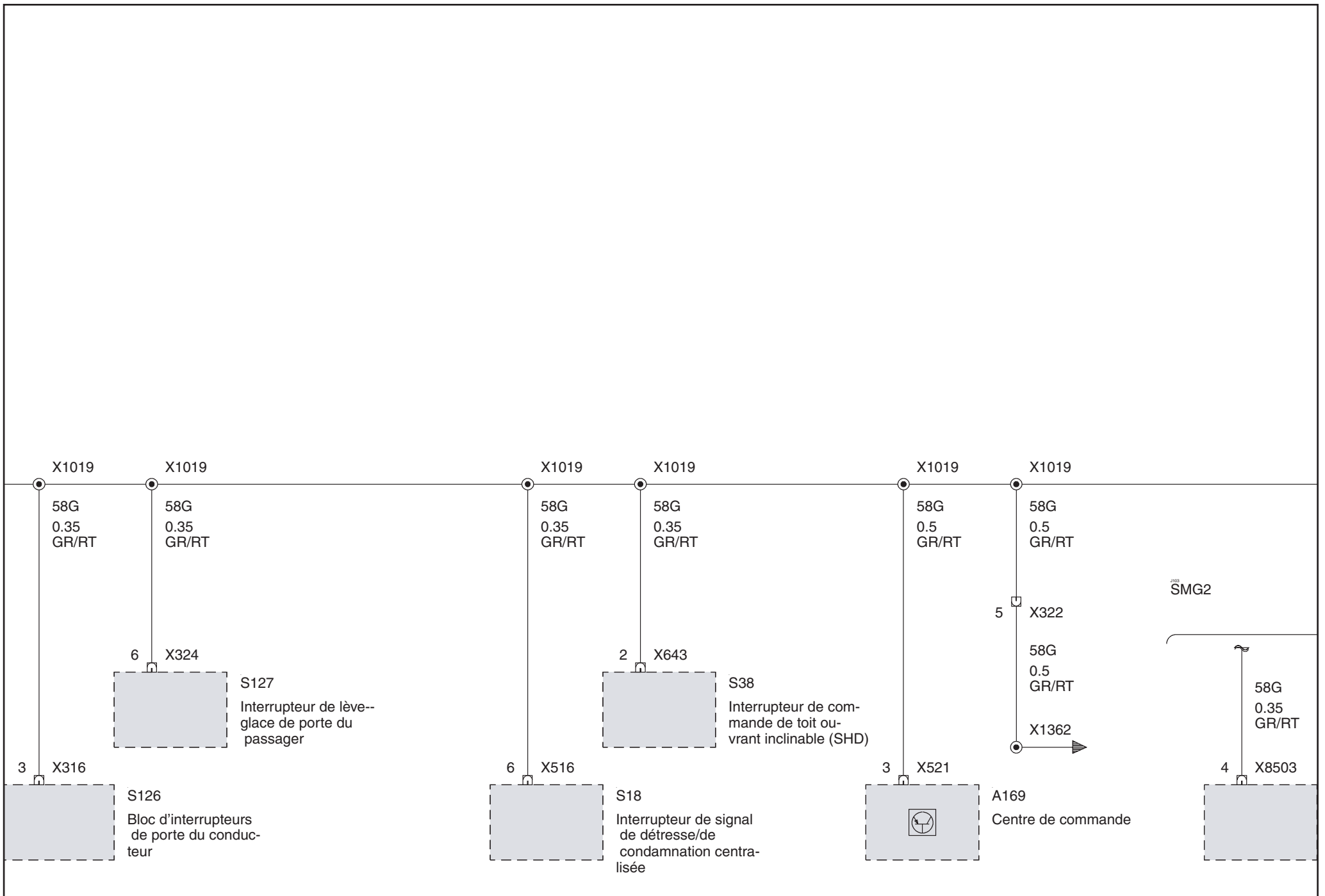

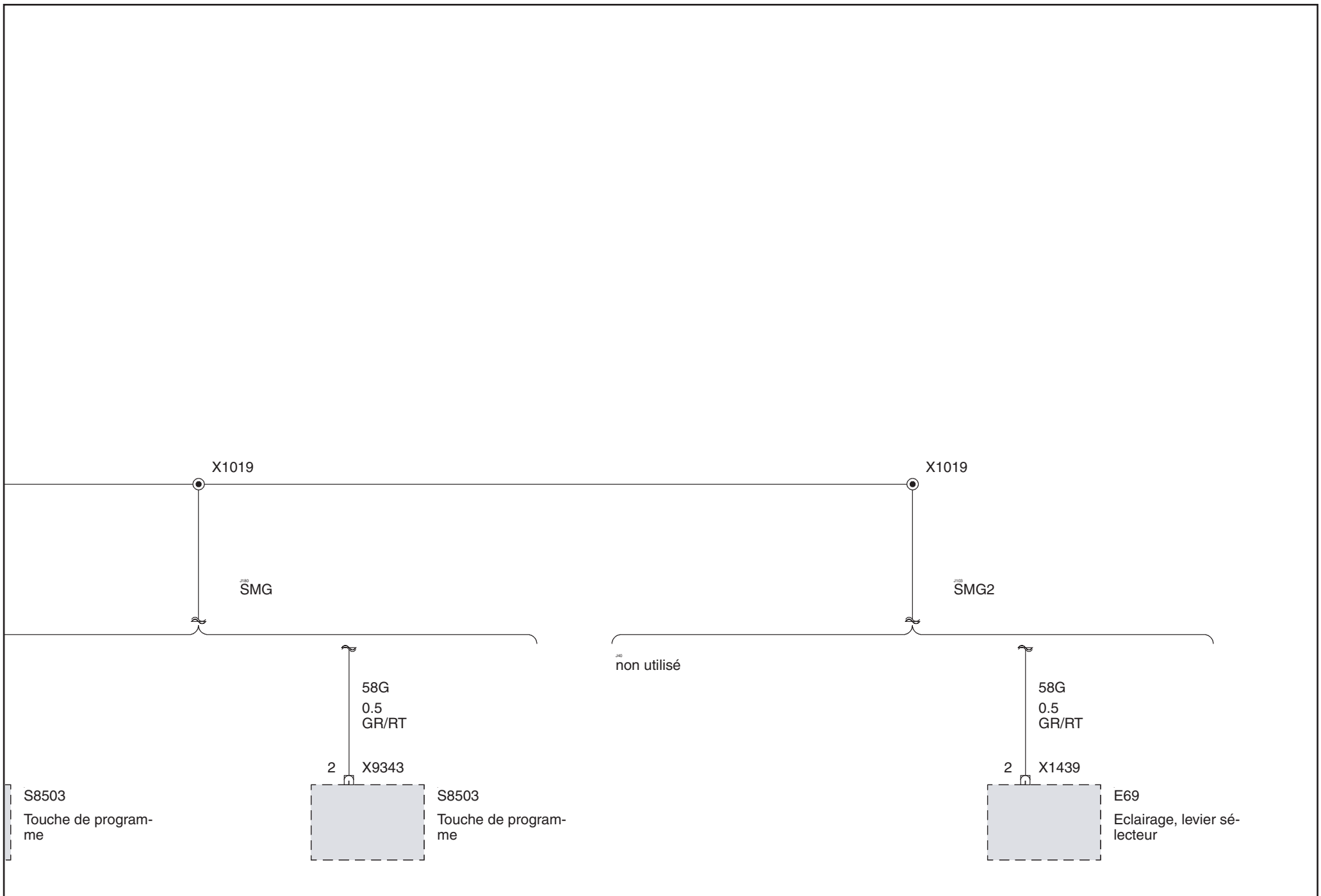

**Fonctions bus**  
**Bus de diagnostic**  
 Connecteur X183

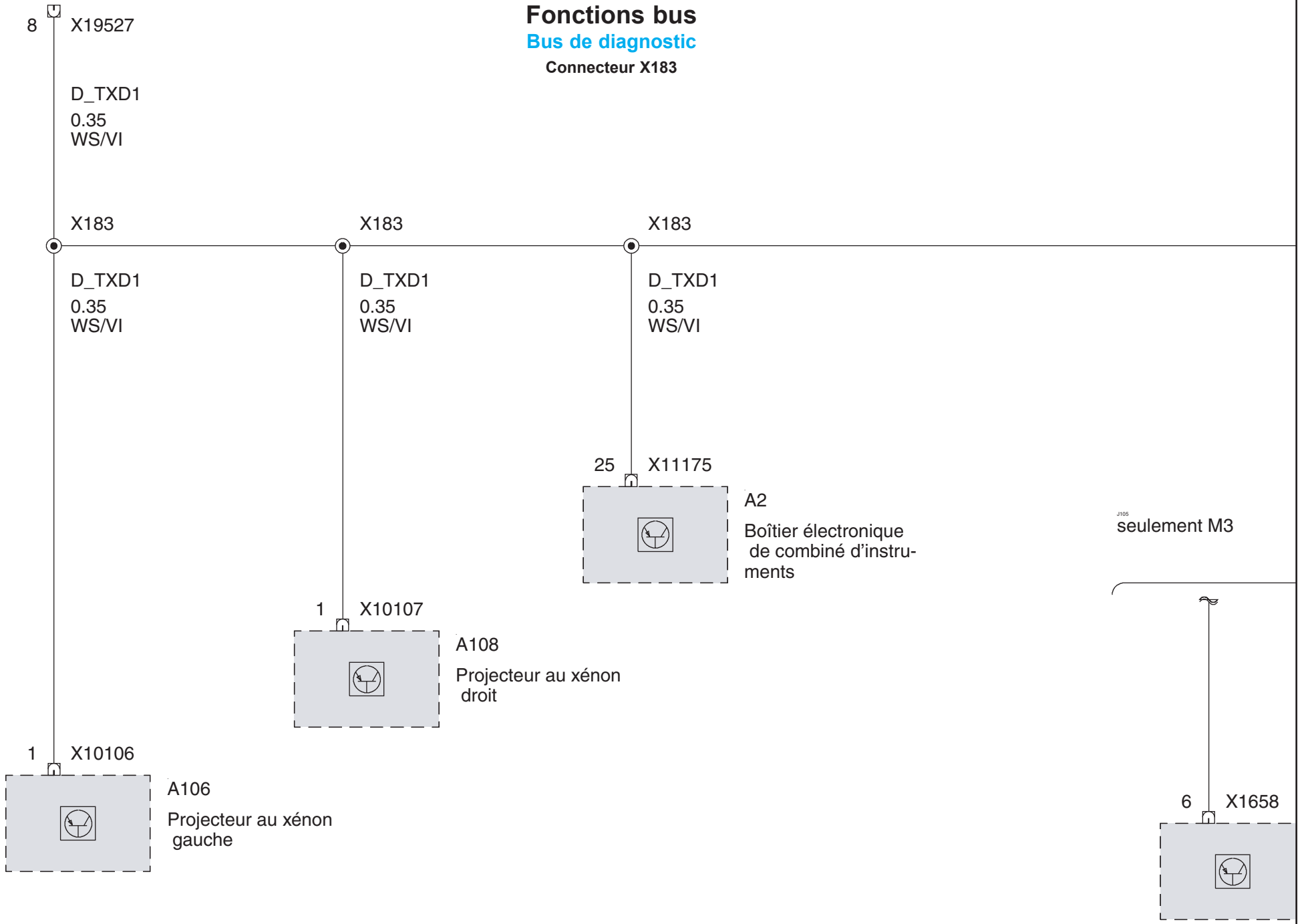

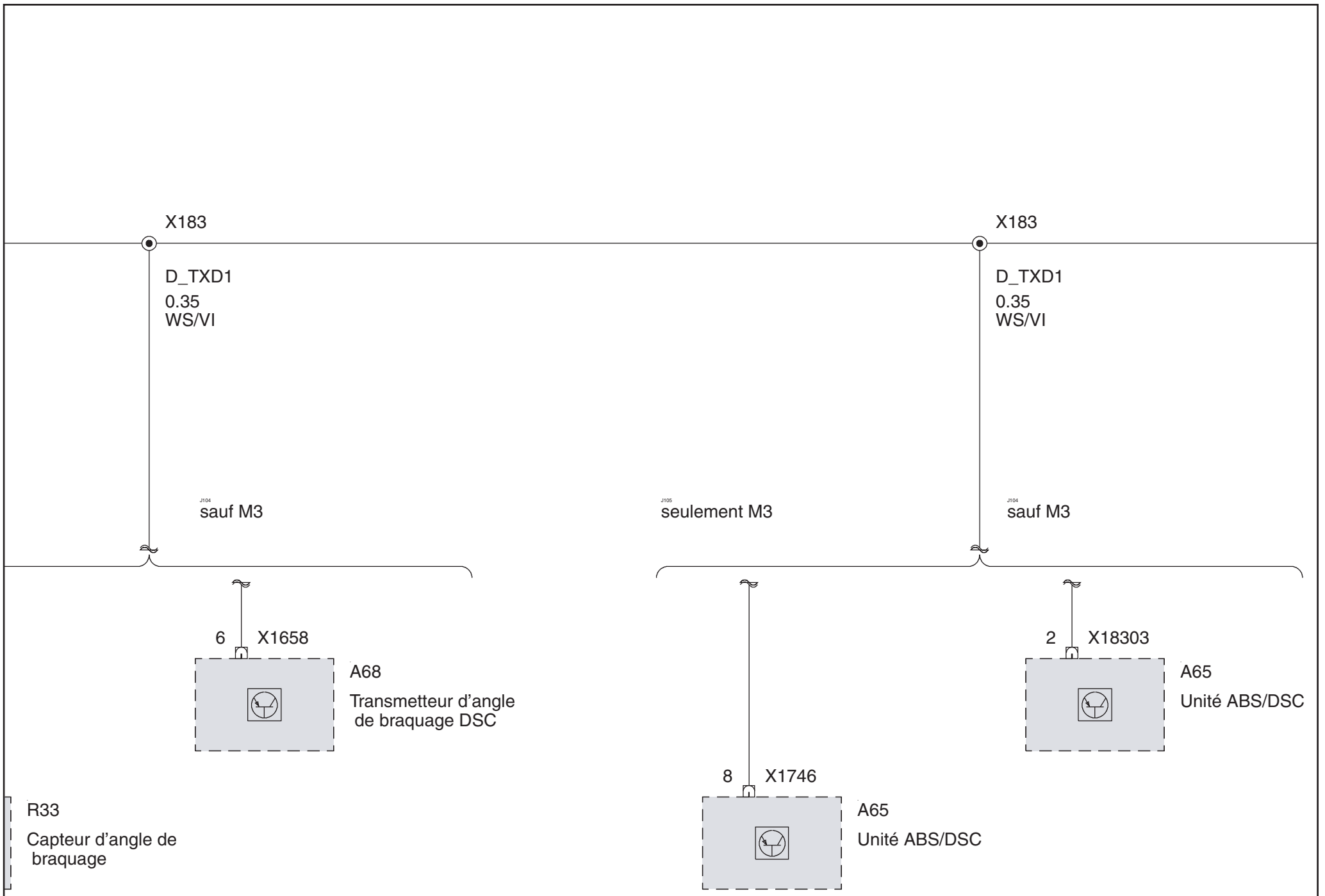

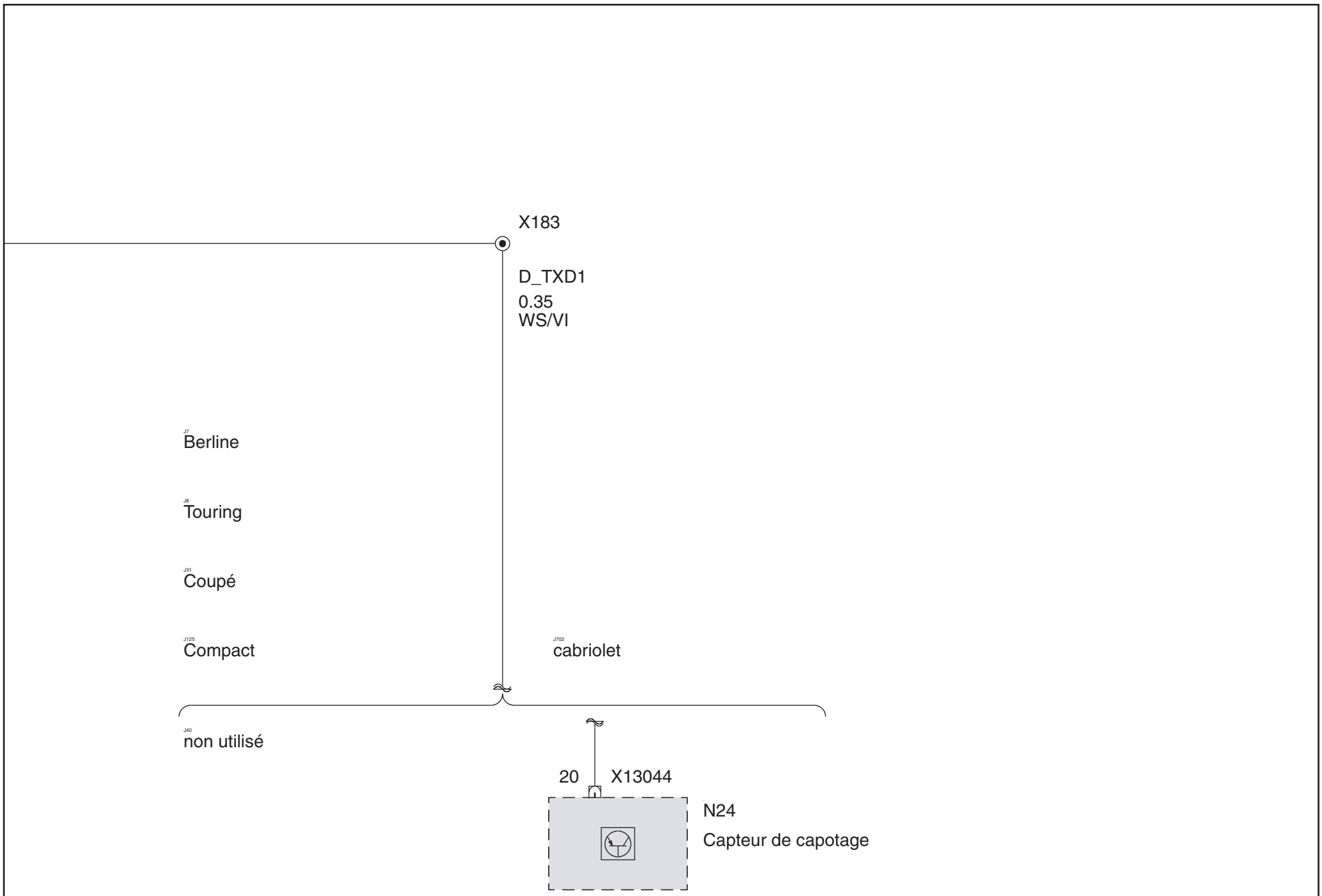

**Bus carrosserie (Bus K)**  
Connecteur X10116

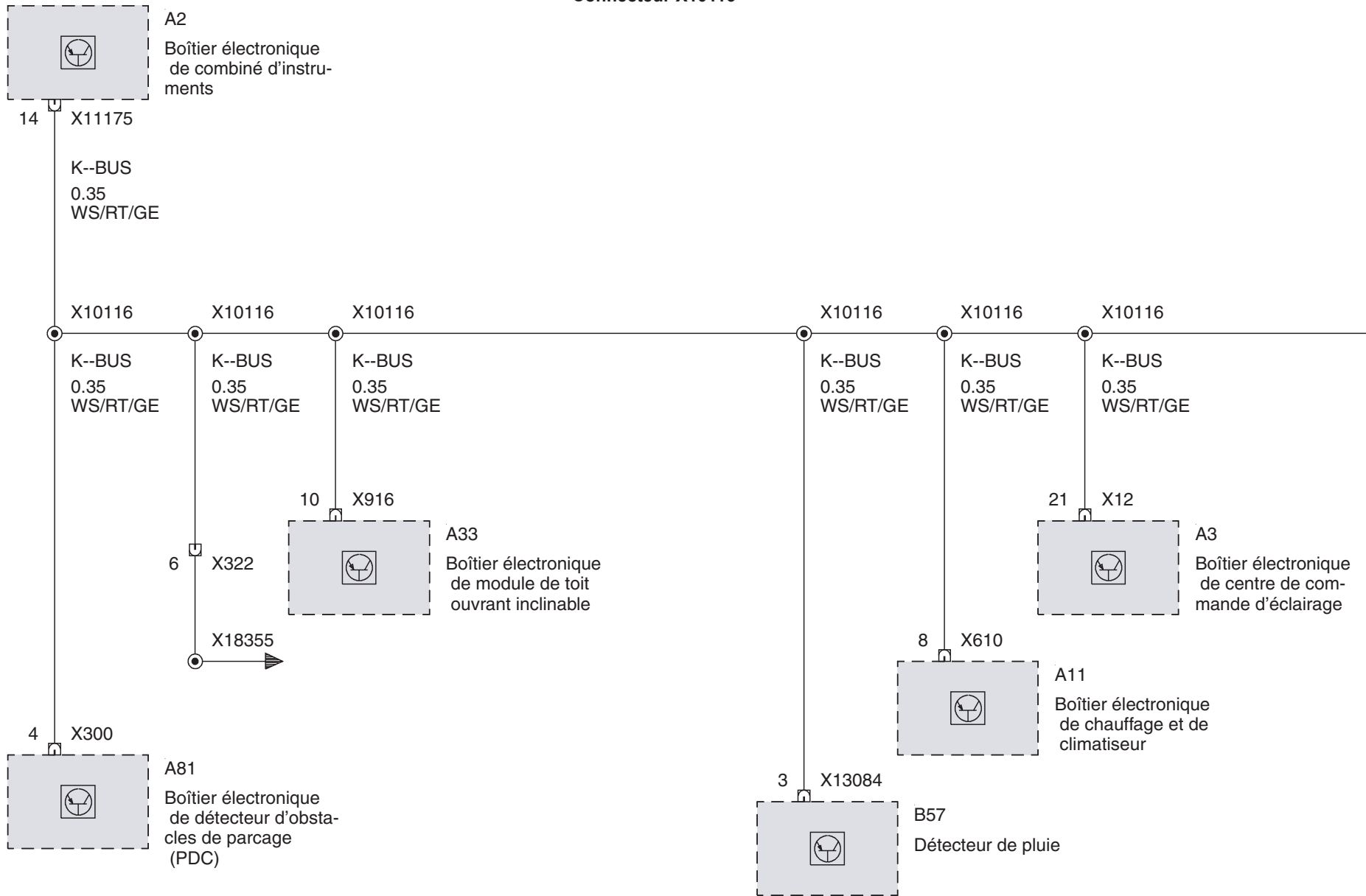



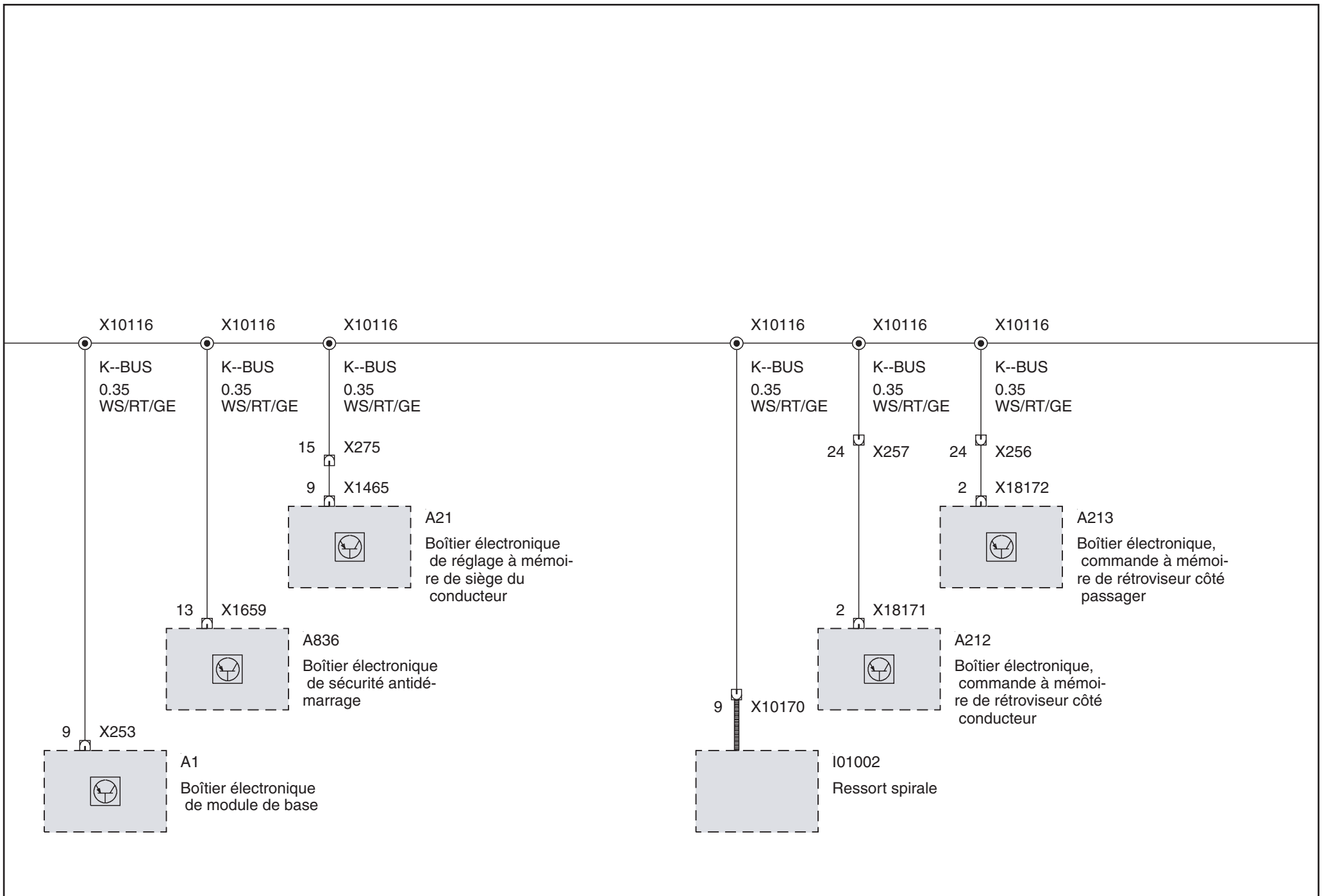

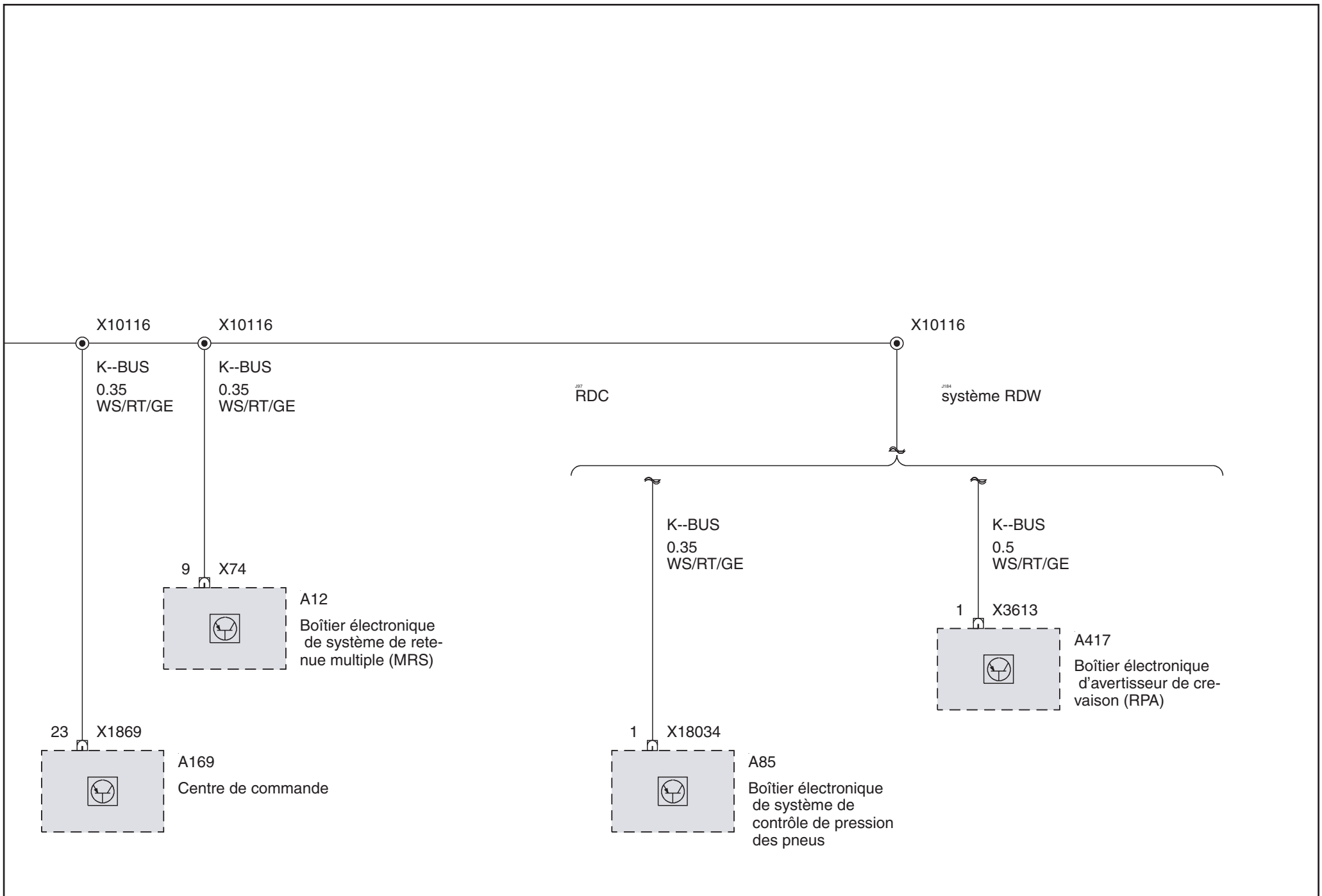

## Bus CAN

Connecteur de bus CAN (DME Electronique moteur MS43 avec DSC MK20 Contrôle dynamique de stabilité)

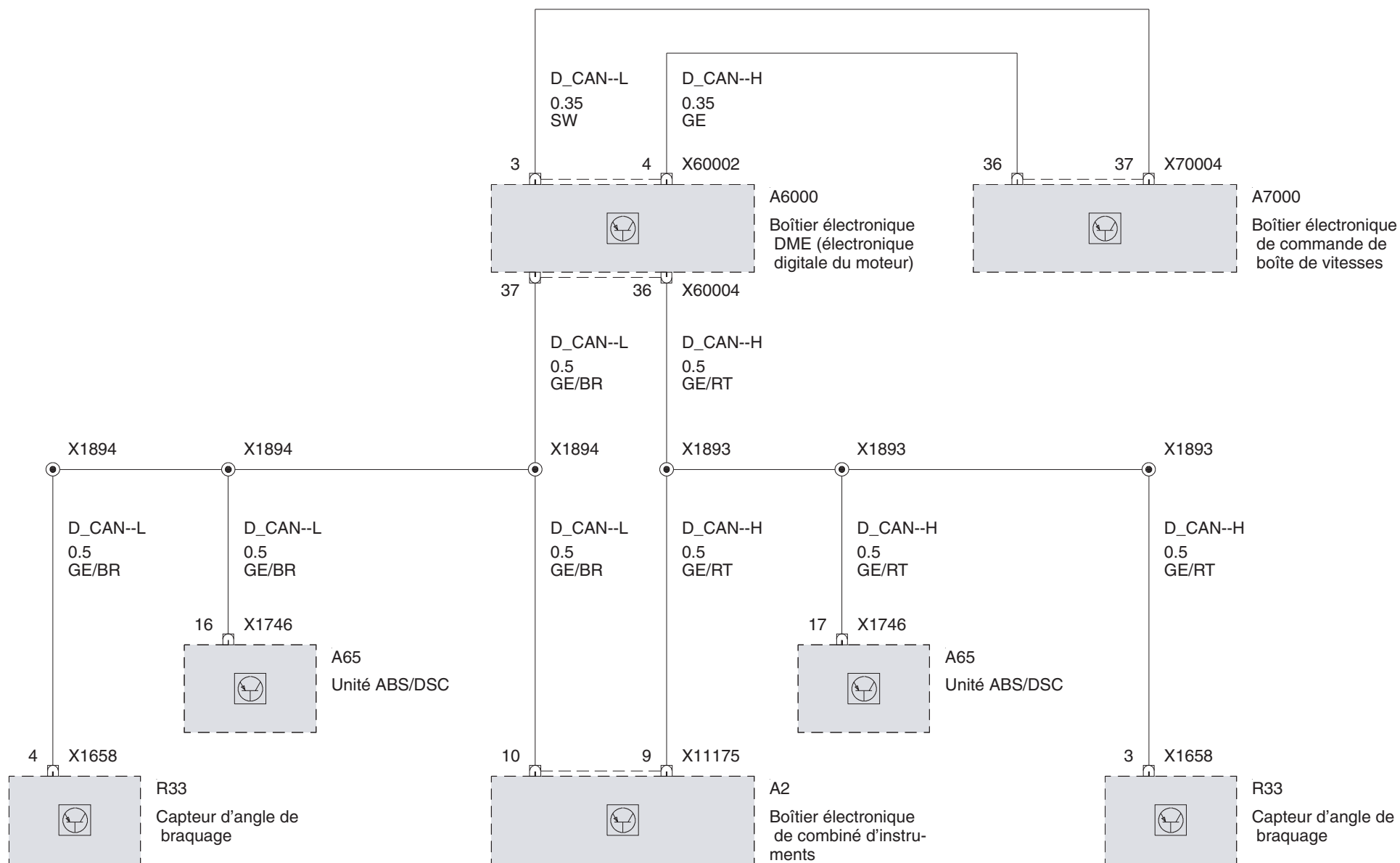

Connecteur de bus CAN (DDE Electronique Diesel DDE50)

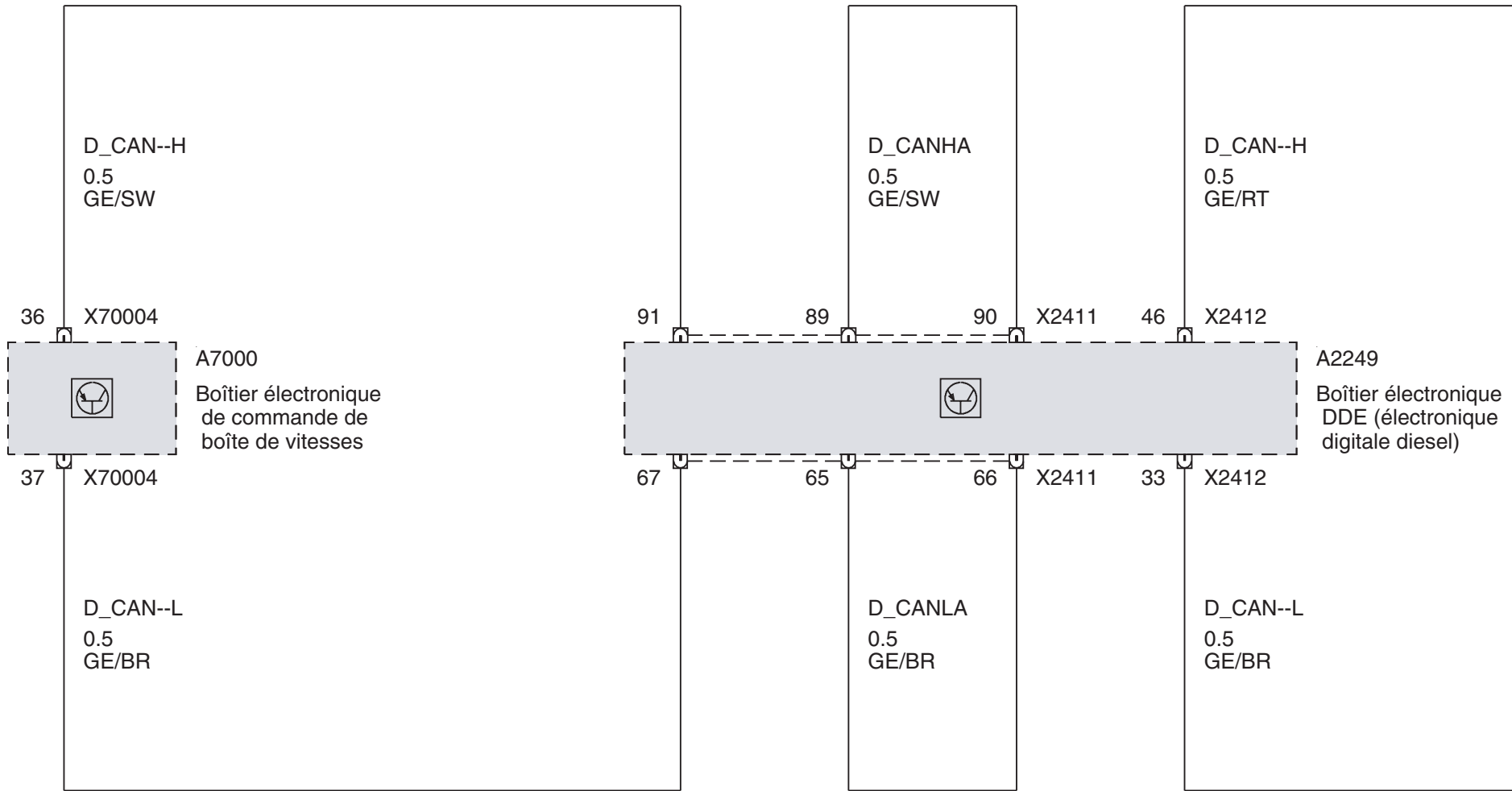

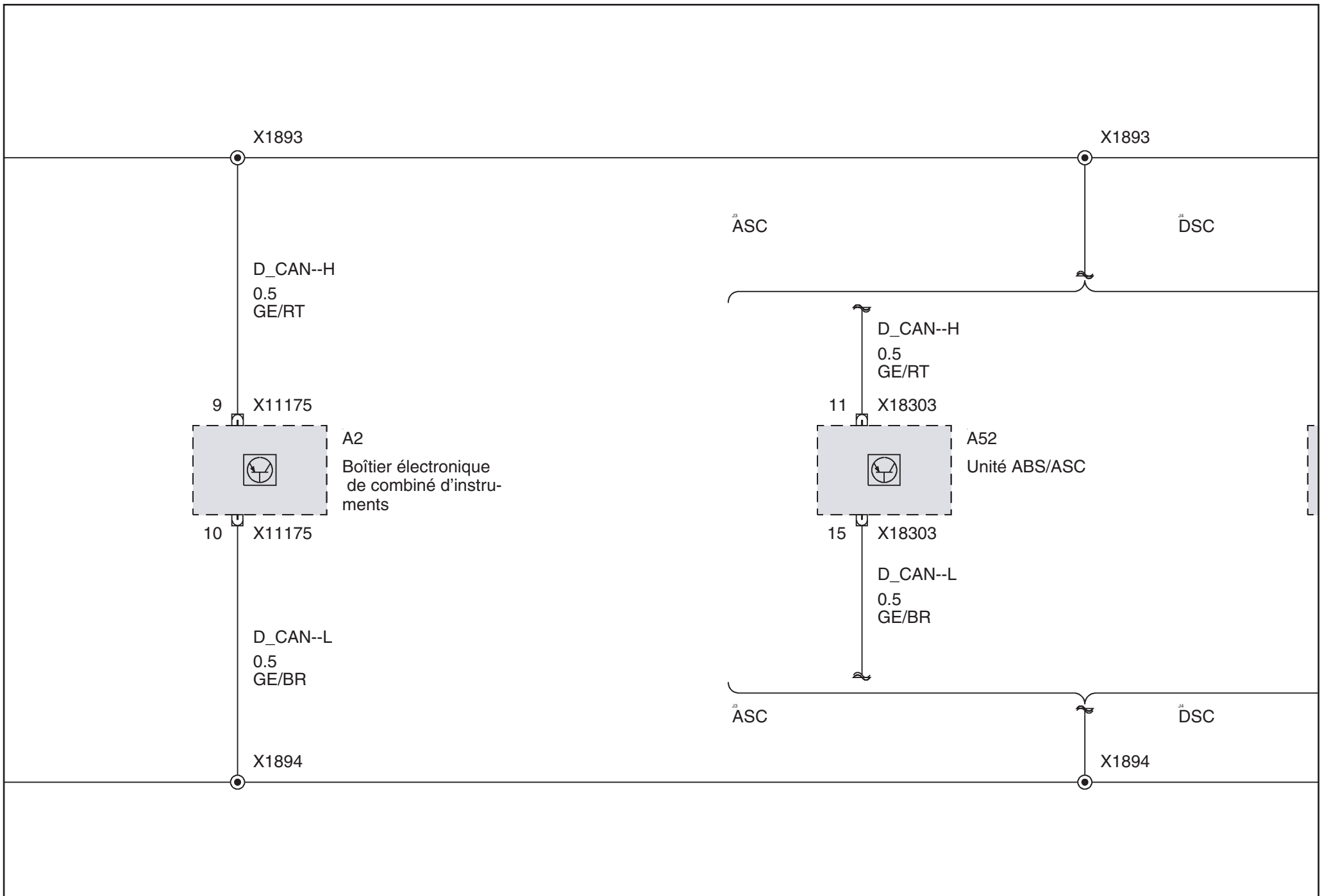

<sup>1177</sup>  
DSC, transmission in-  
tégrale

<sup>15</sup>  
ASC

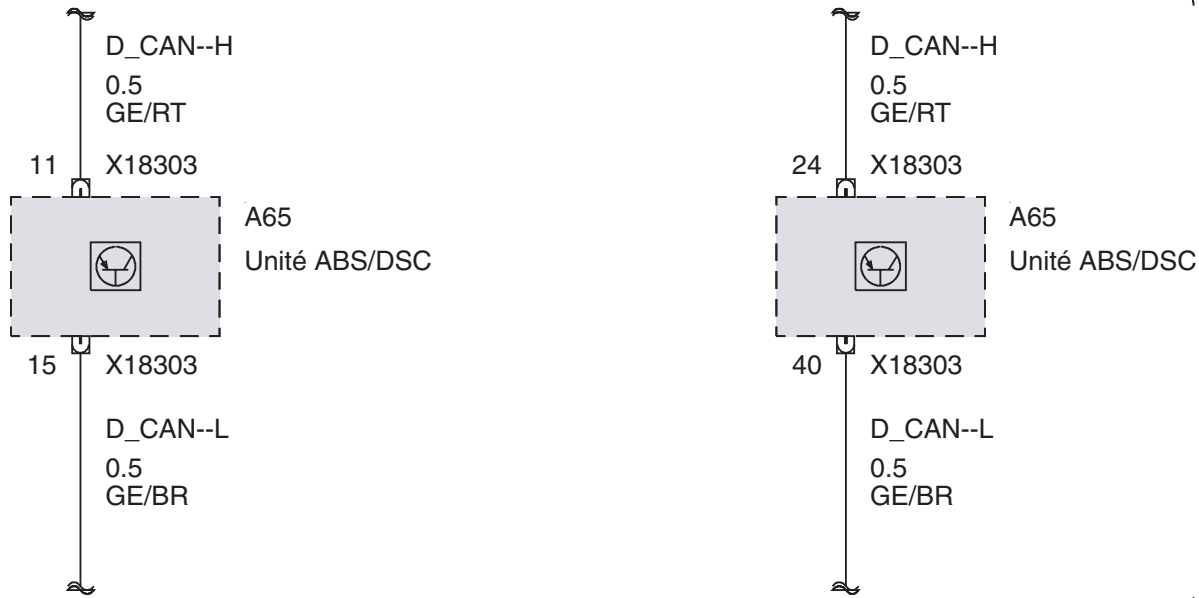

<sup>140</sup>  
non utilisé

<sup>140</sup>  
non utilisé

<sup>1177</sup>  
DSC, transmission in-  
tégrale

<sup>15</sup>  
ASC

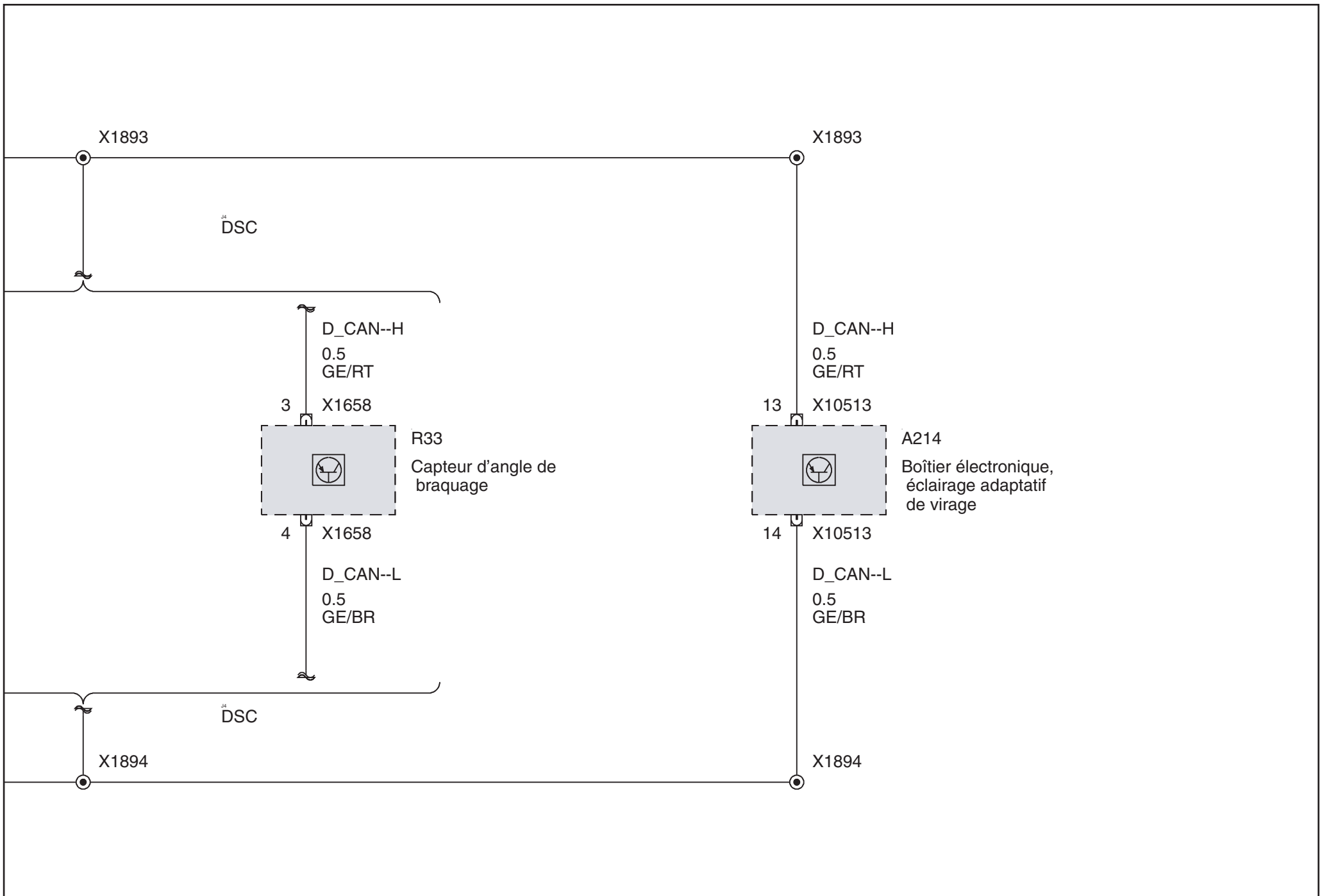

## Connecteur de bus CAN (Essence)

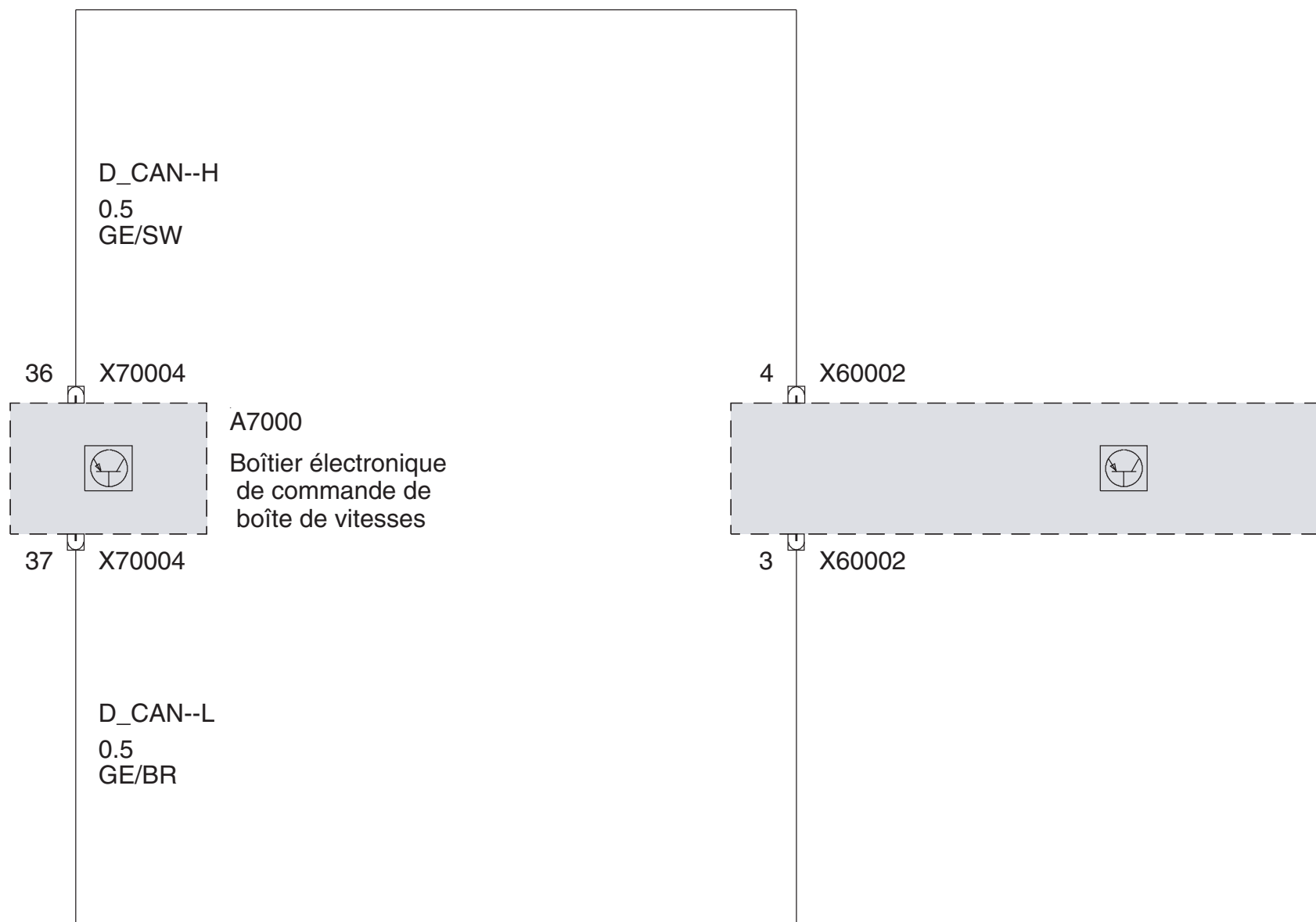



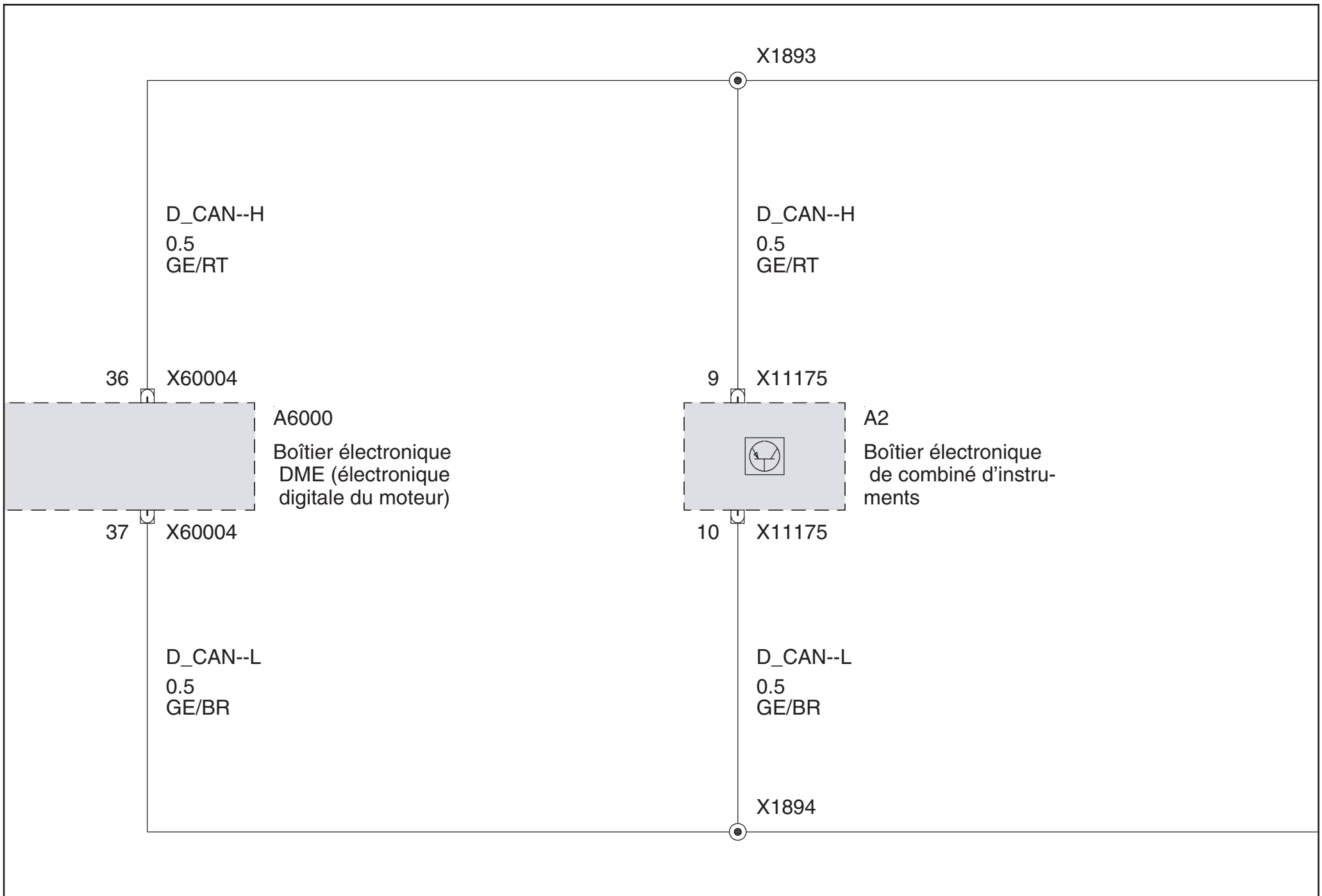

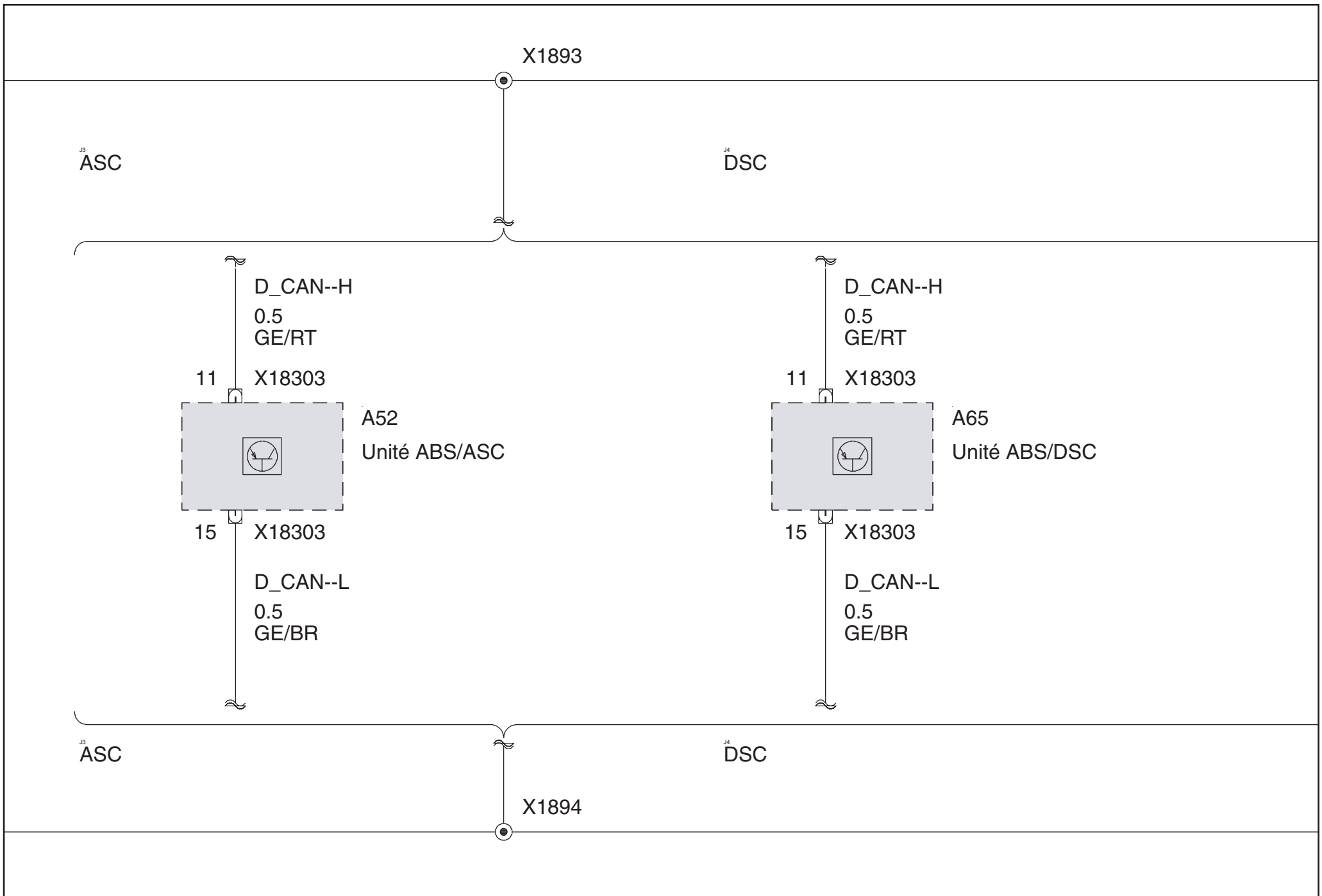



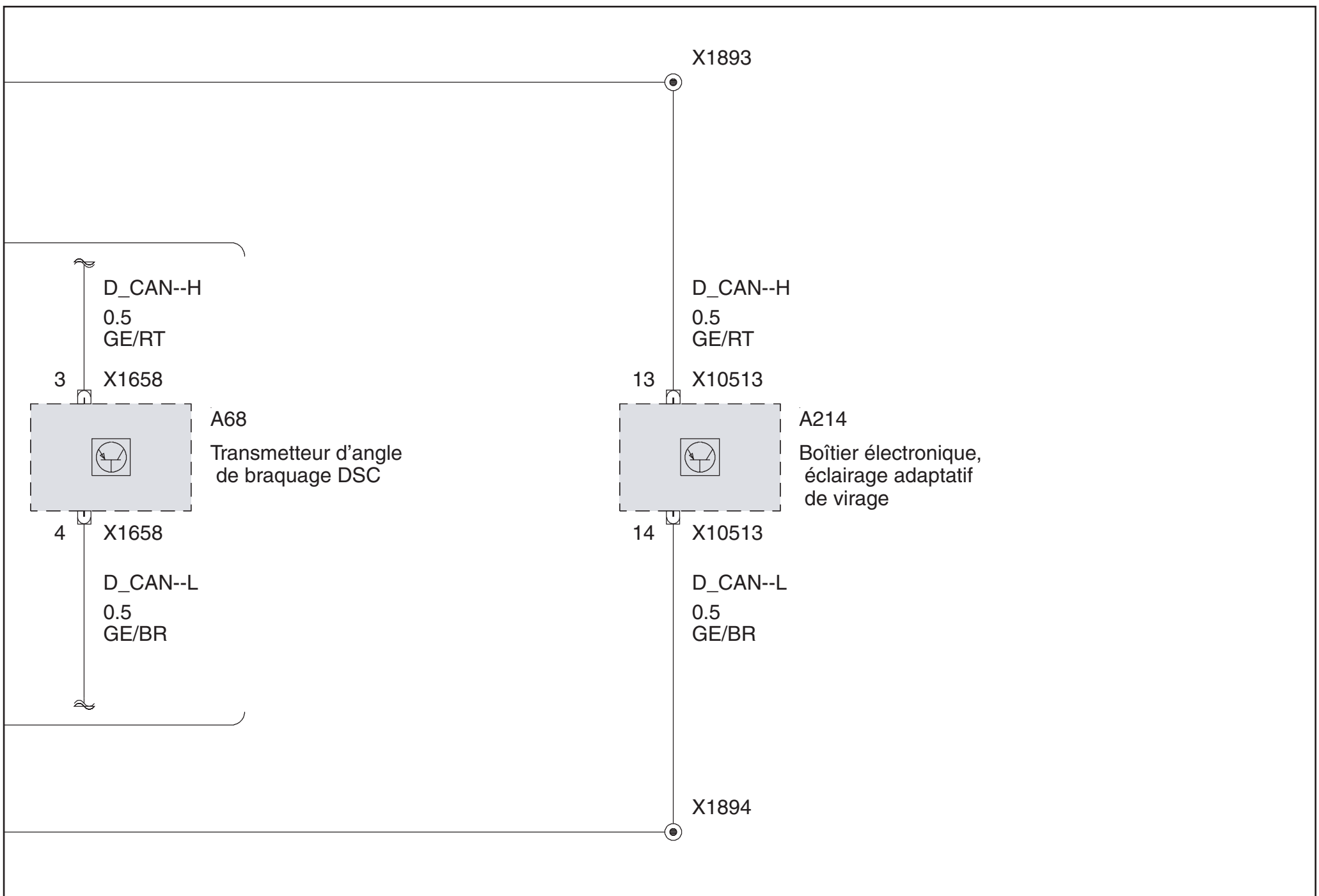

# Fonctions de chauffage et climatisation (IHKA Climatisation automatique ou IHKR Climatisation régulée)

Fonctions de chauffage et climatisation (Essence)

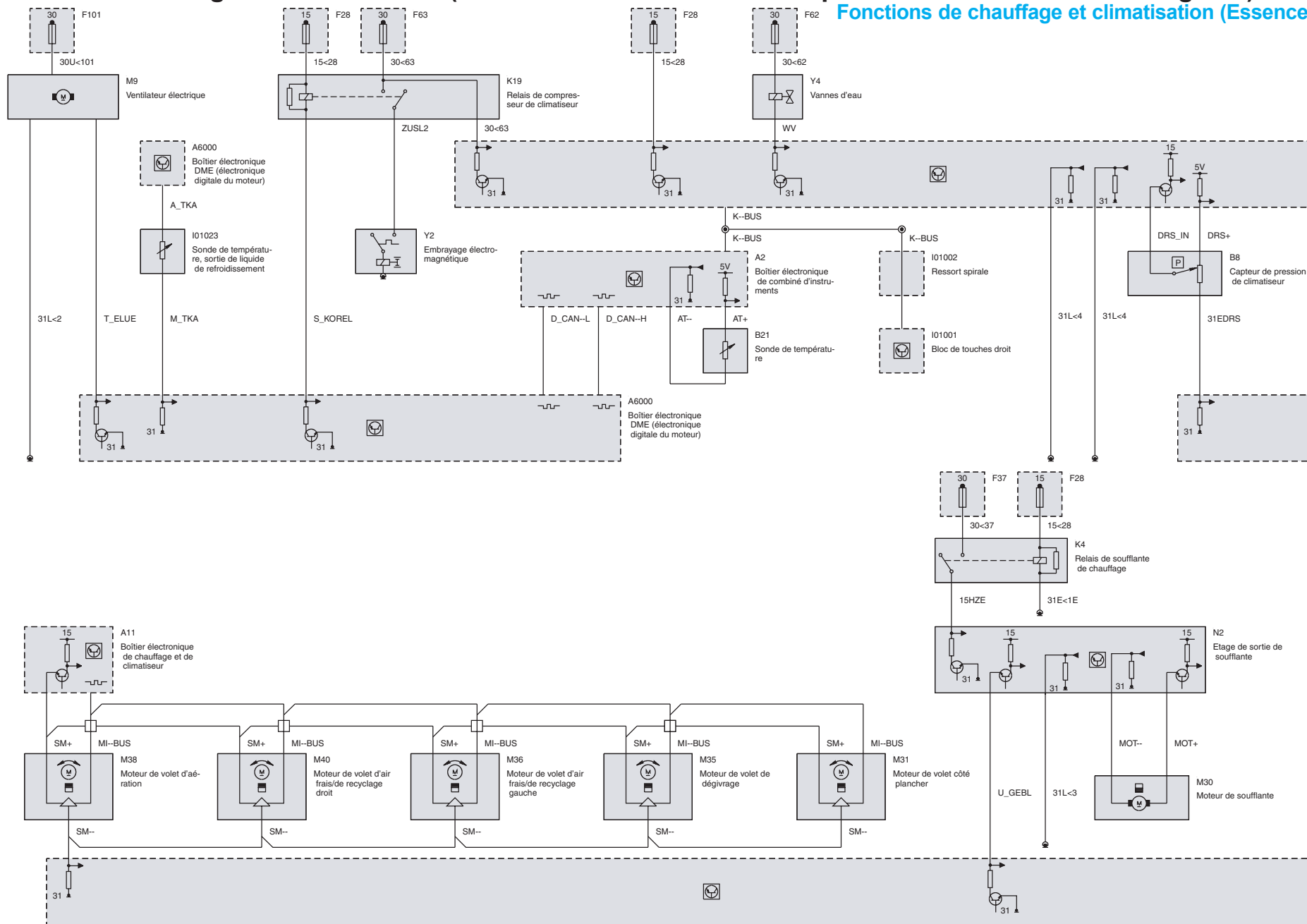

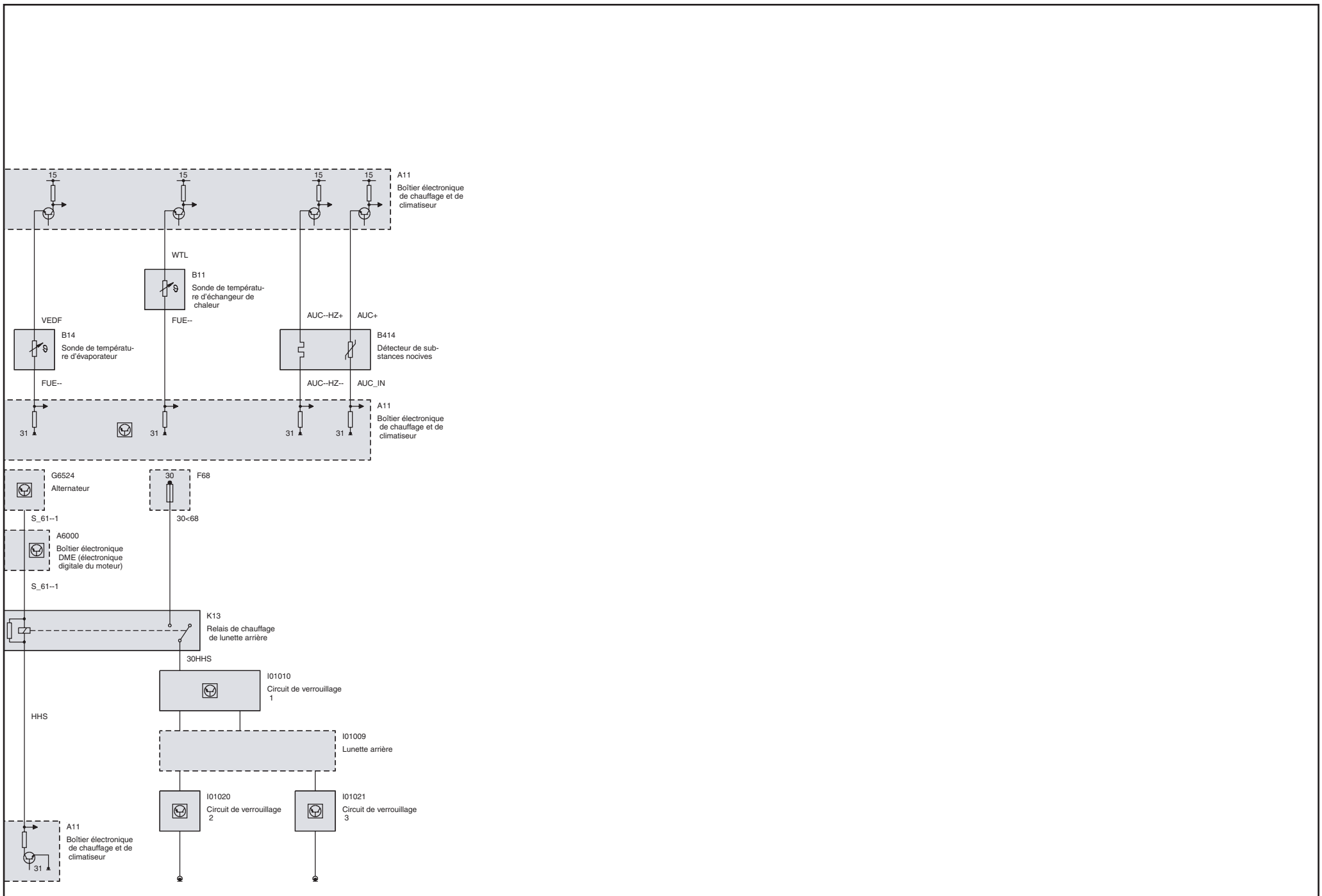



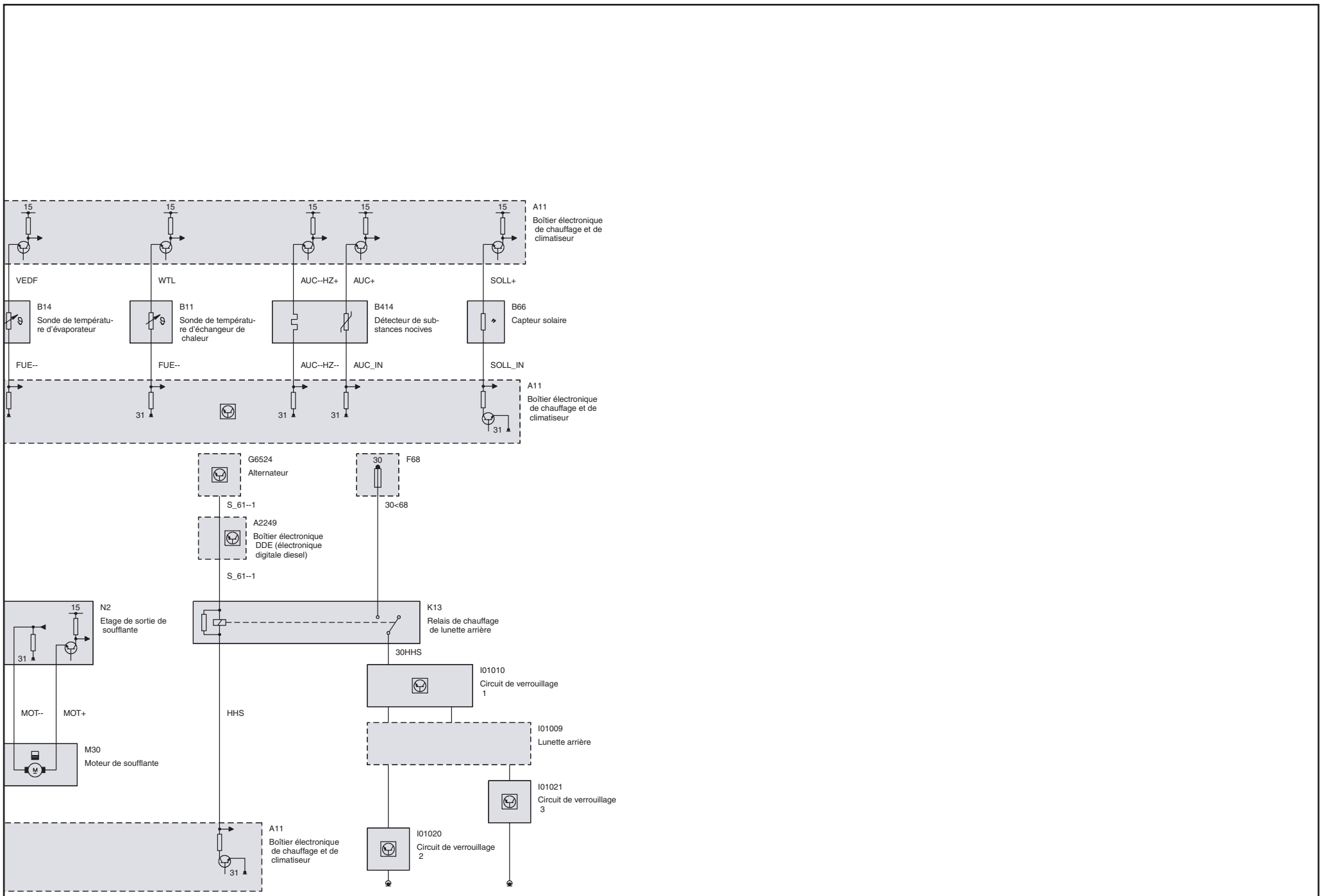



Fonctions de chauffage et climatisation (Diesel avec IHKR)

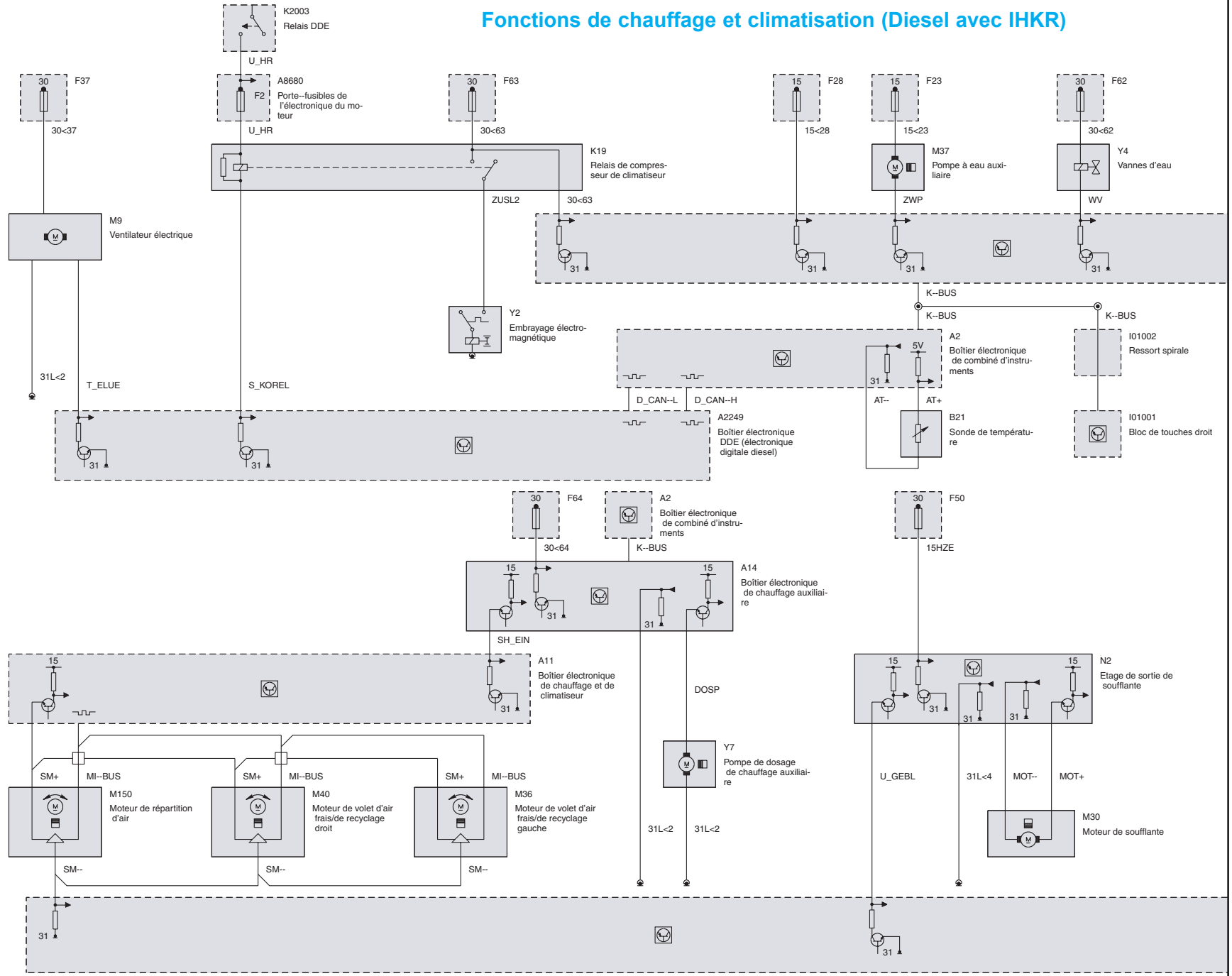

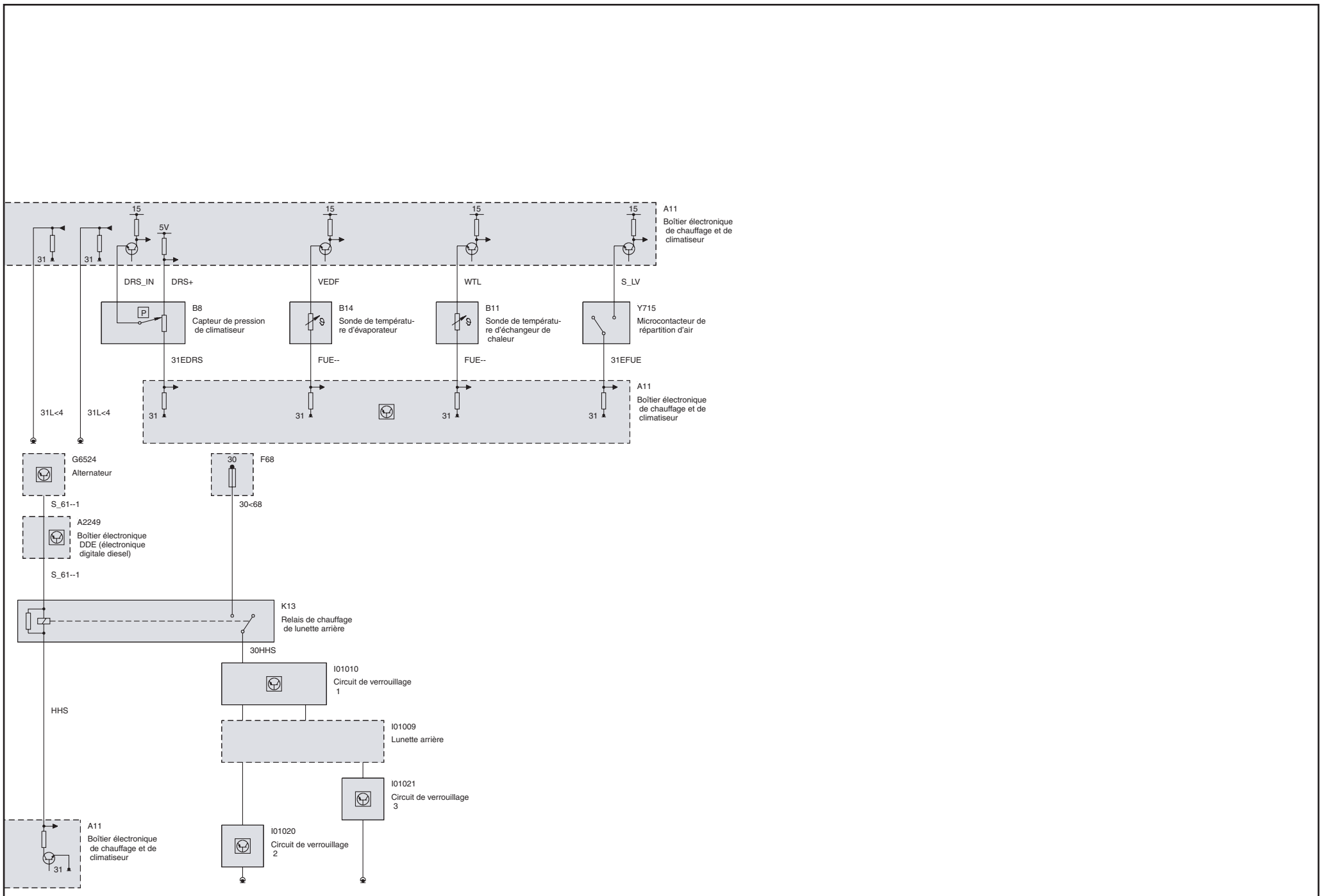

Alimentation (sauf Commande du chauffage)

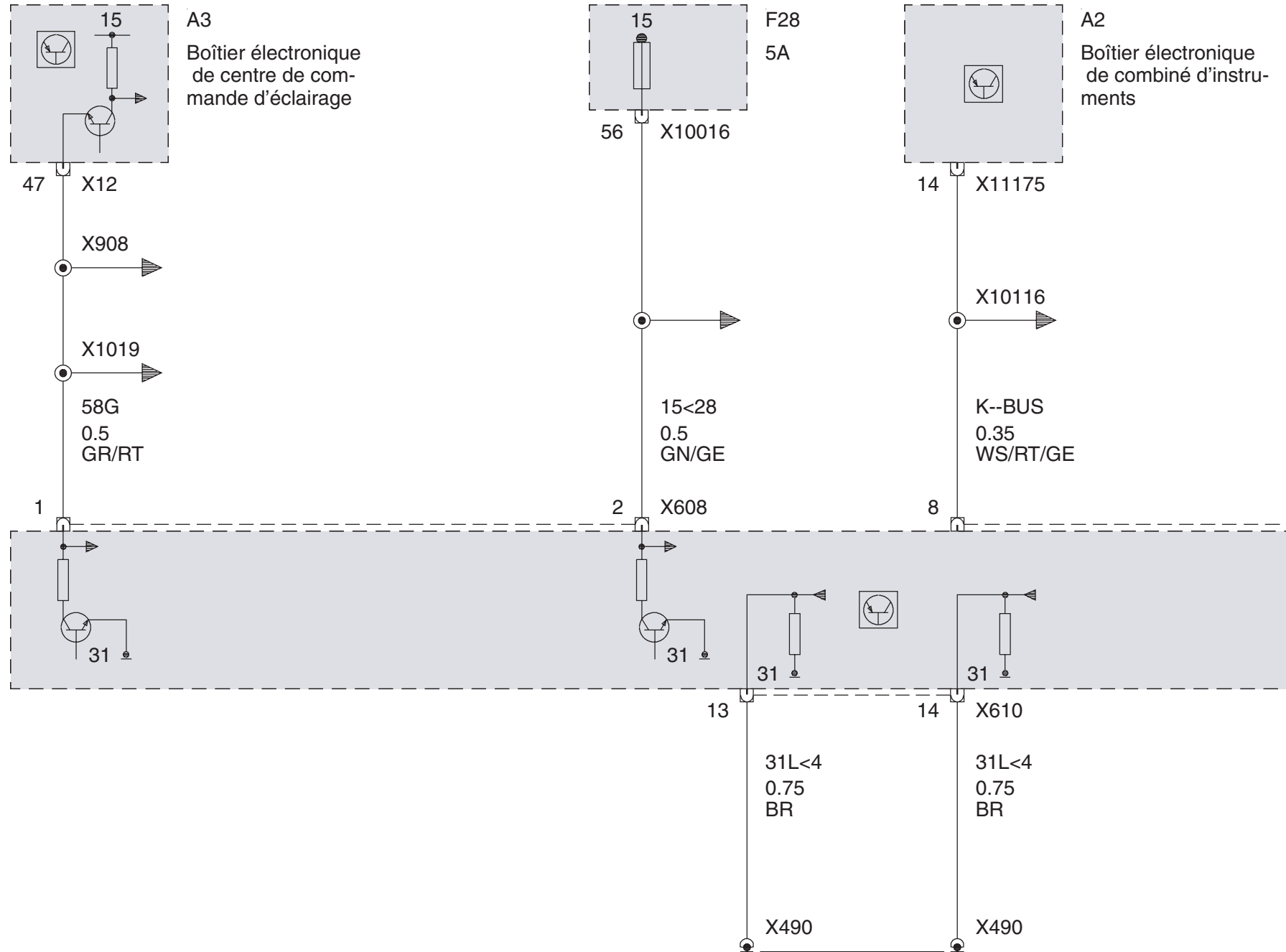

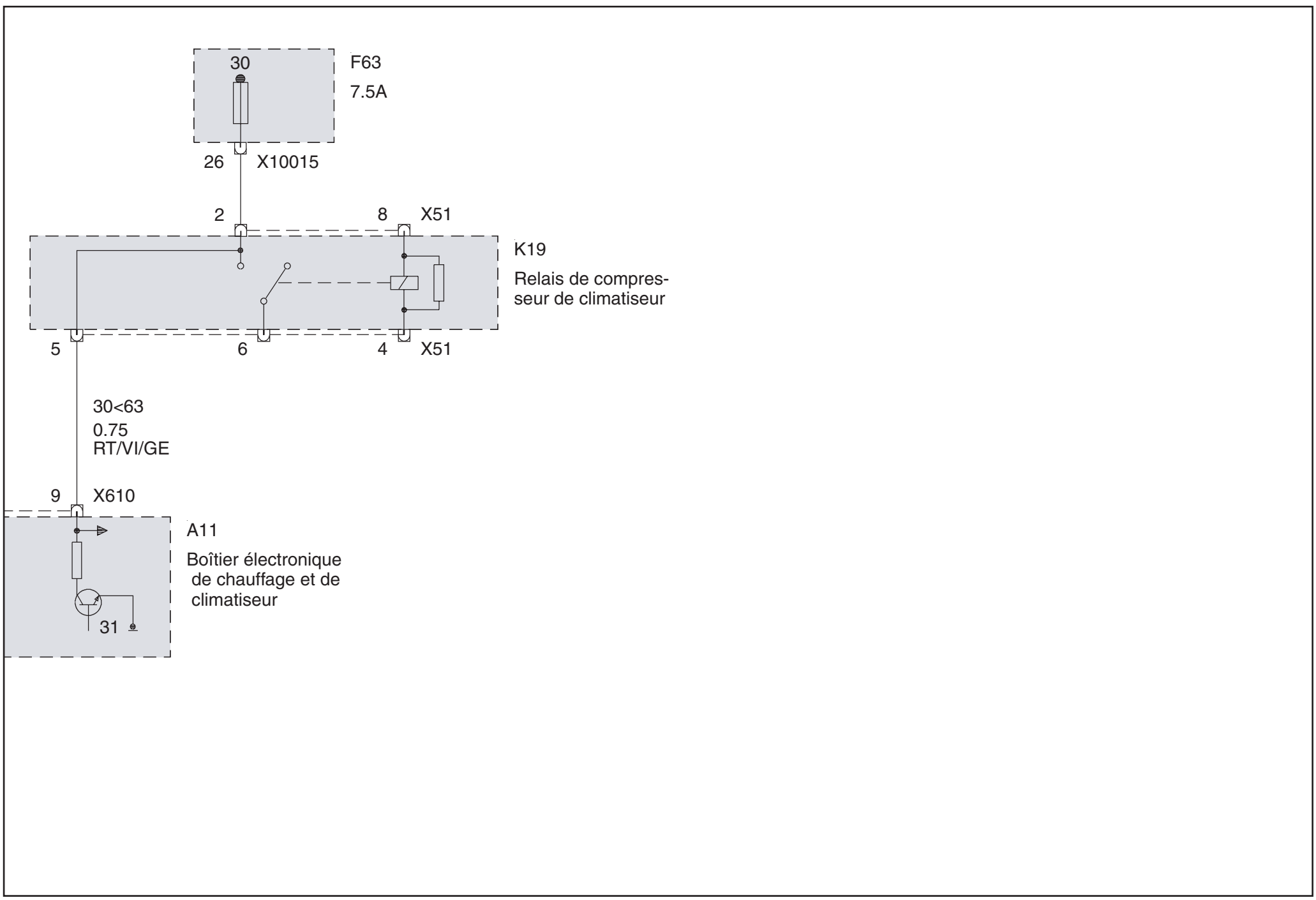

Touches recyclage d'air/chauffage lunette AR (Diesel avec Commande du chauffage)

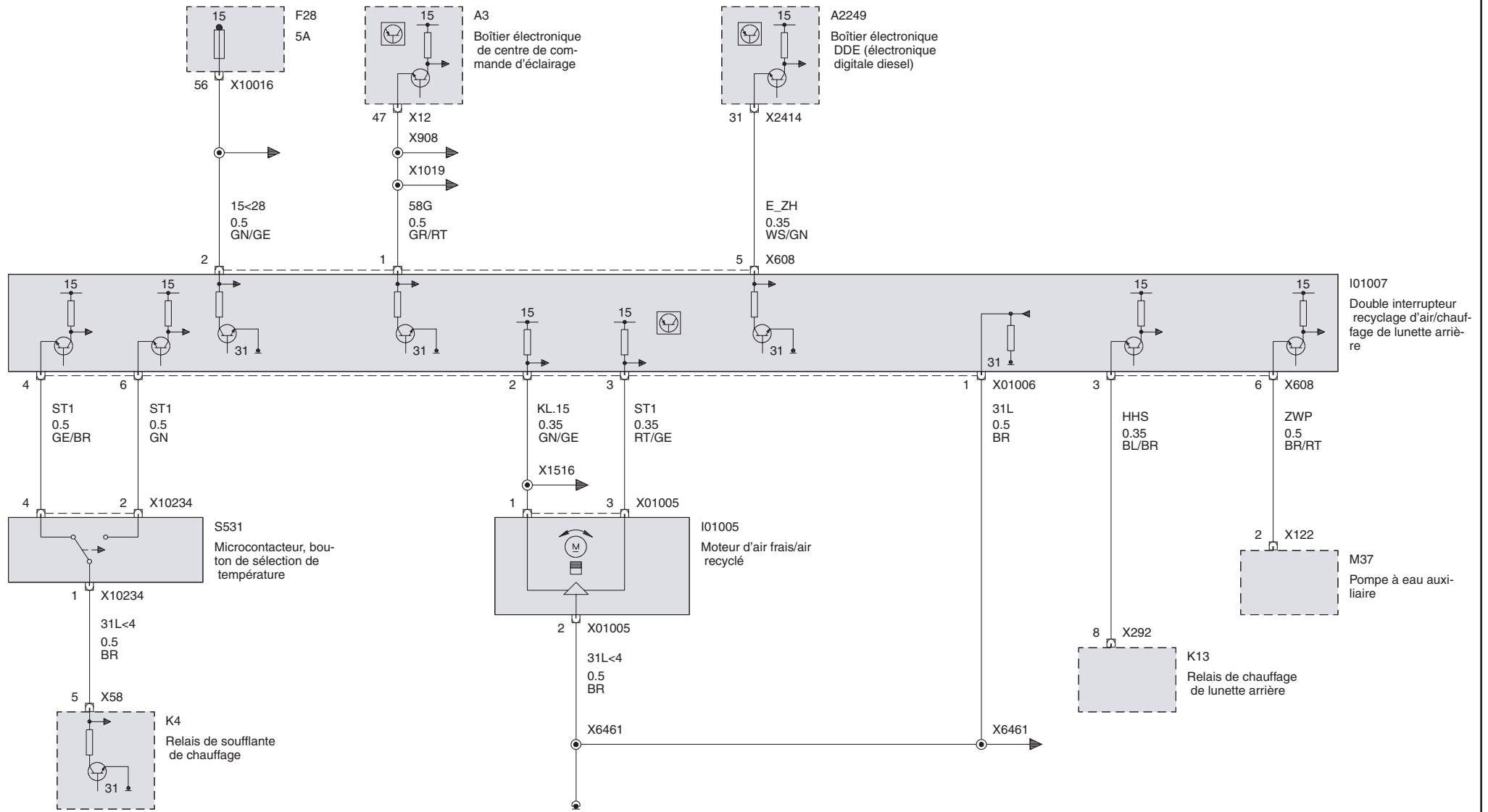

Commande soufflante (Diesel avec Commande du chauffage)

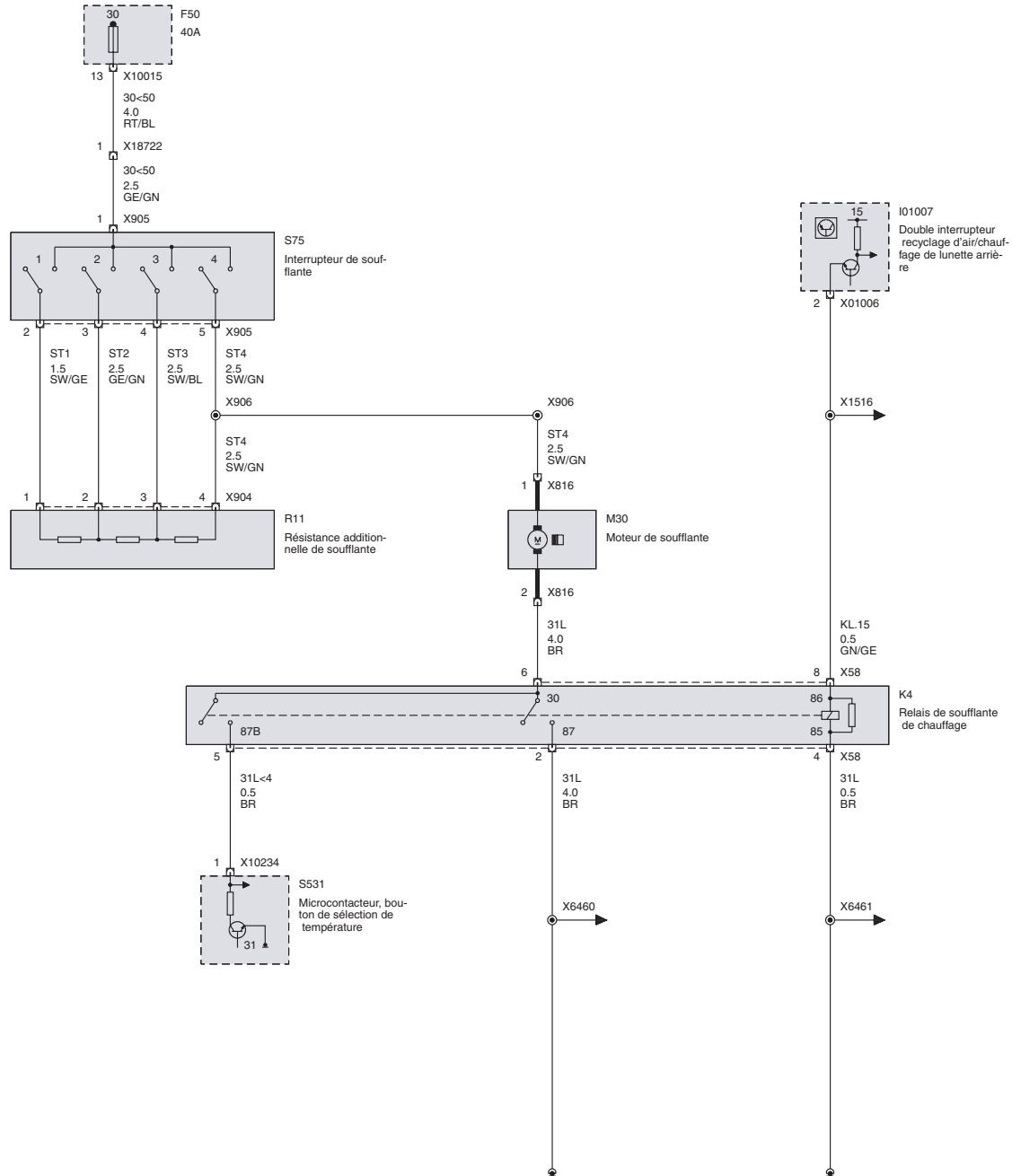

Commande soufflante (avec IHKA / IHKR)

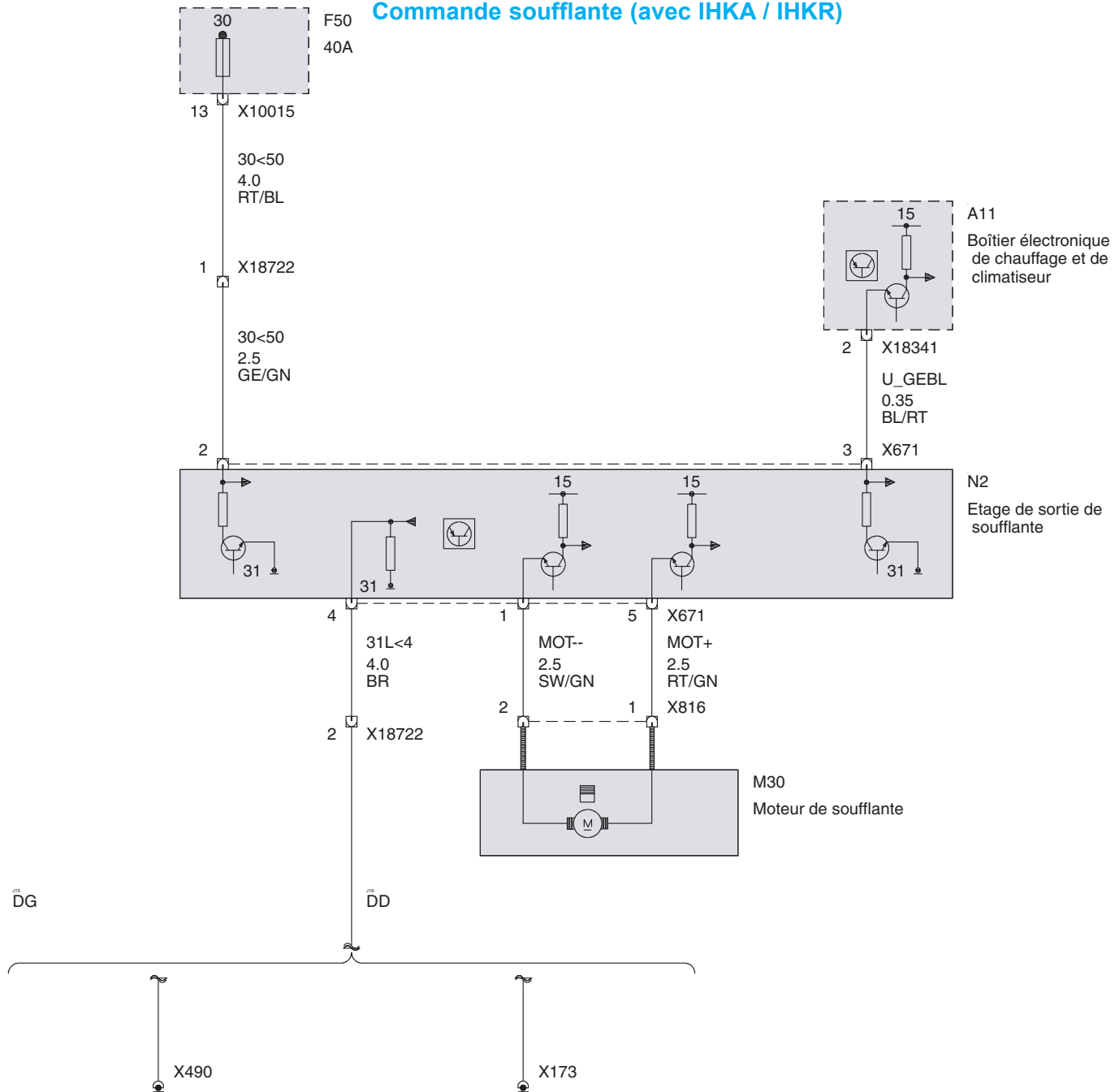

Admission d'air et dégivrage (IHKA)

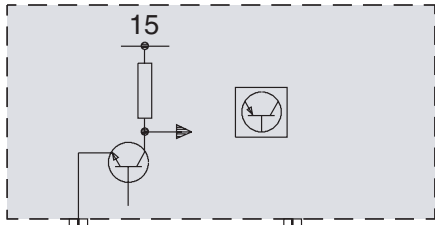

A11  
Boîtier électronique  
de chauffage et de  
climatiseur

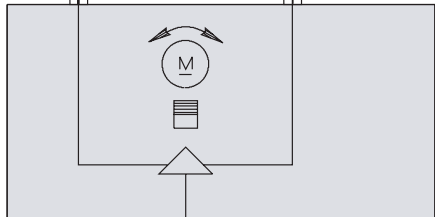
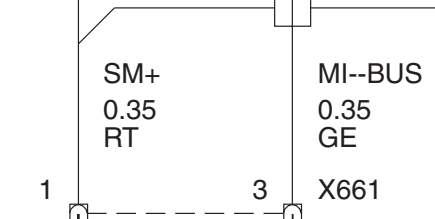
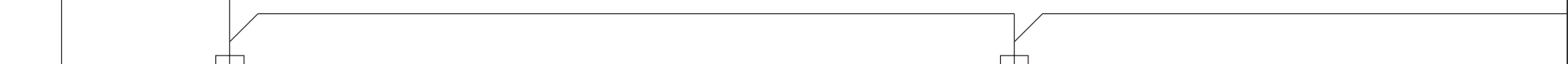

M38  
Moteur de volet d'aé-  
ration

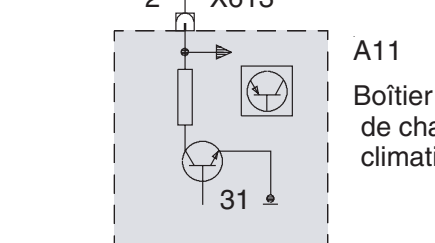
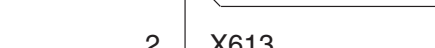
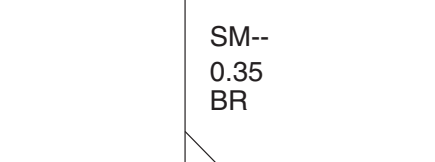
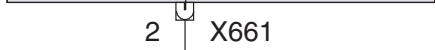

A11  
Boîtier électronique  
de chauffage et de  
climatiseur

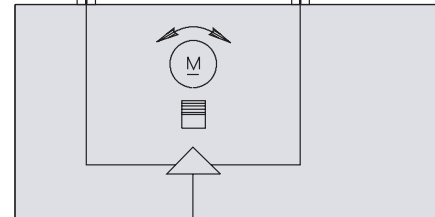
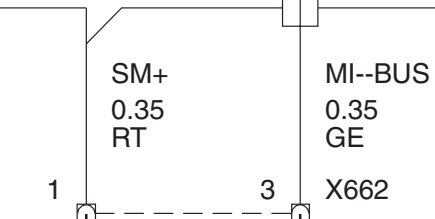

M40  
Moteur de volet d'air  
frais/de recyclage  
droit





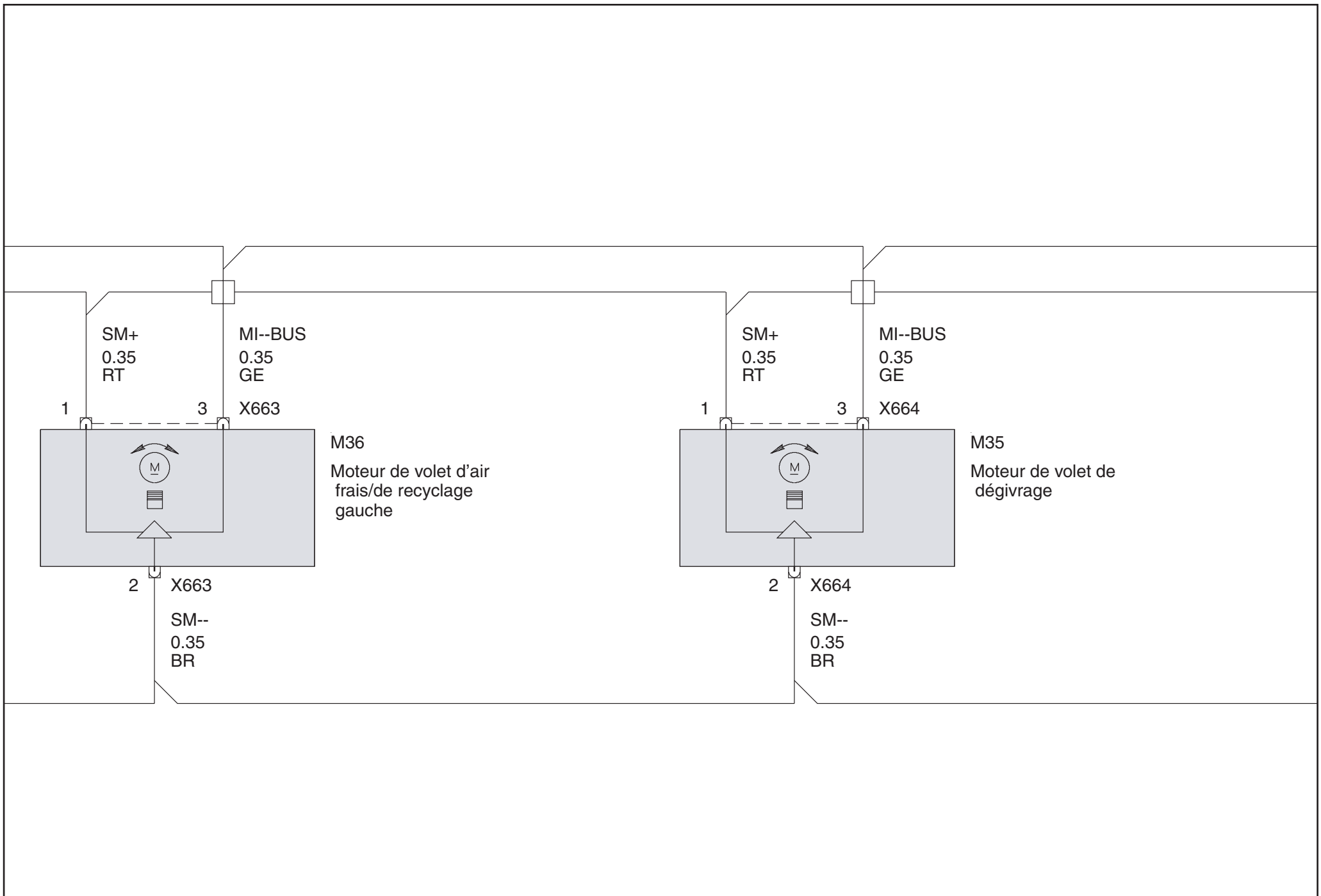

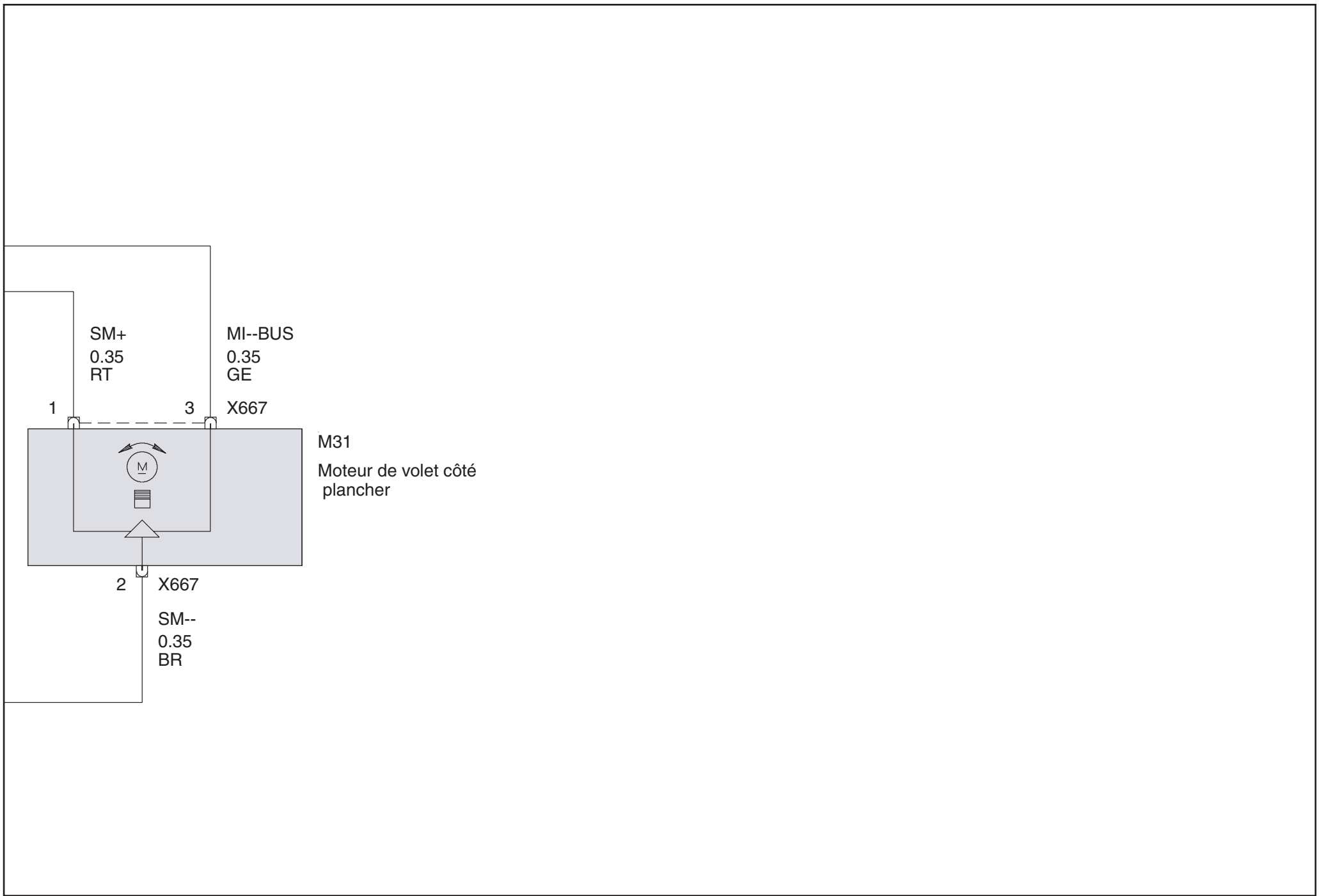

Admission d'air et dégivrage (IHKR)

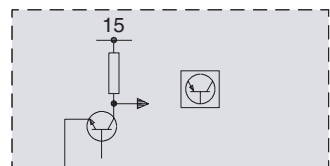

A11  
Boîtier électronique  
de chauffage et de  
climatiseur

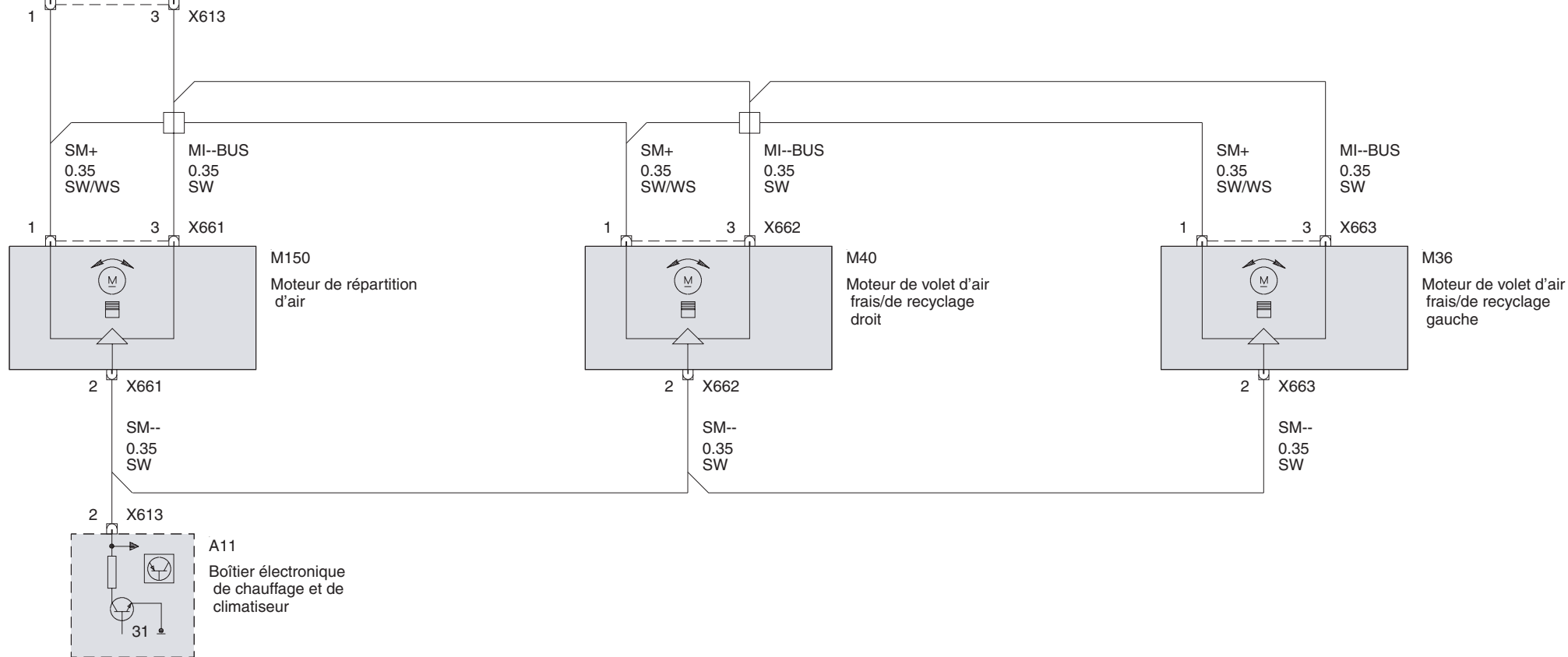

Capteur AUC (Recyclage automatique de l'air intérieur) (IHKA)

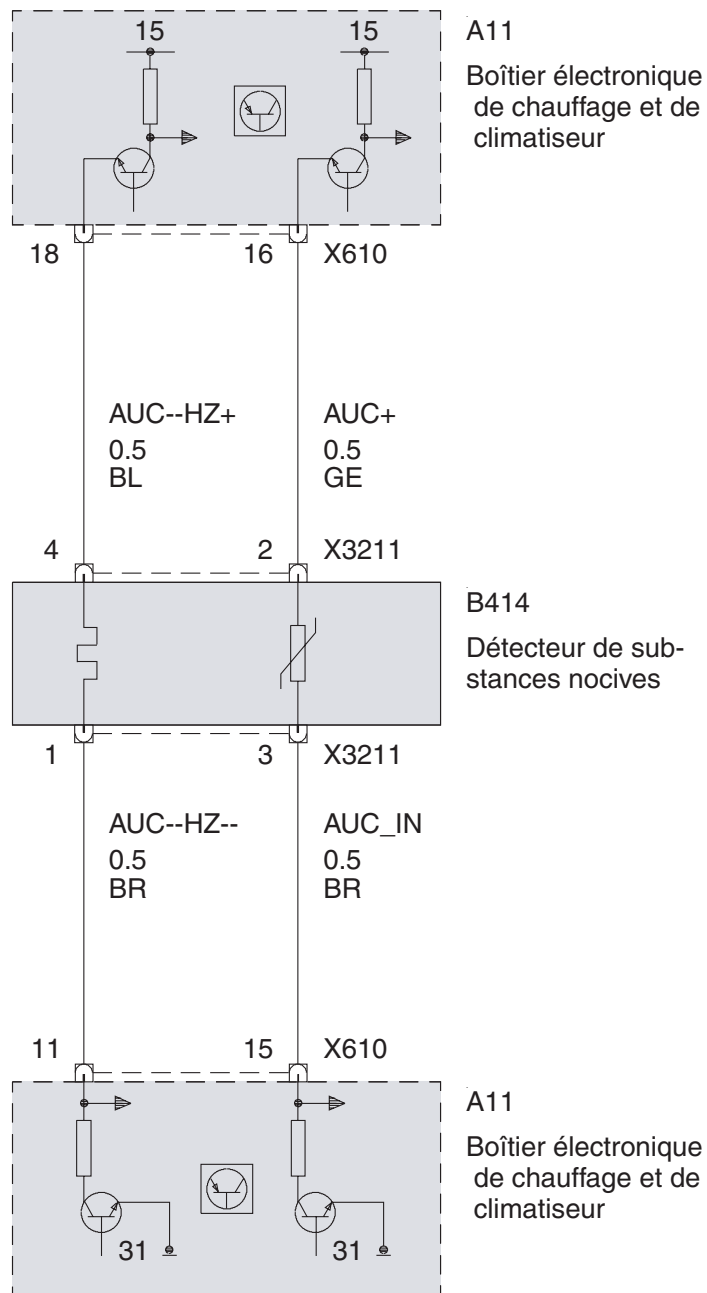

Sonde de l'échangeur de chaleur

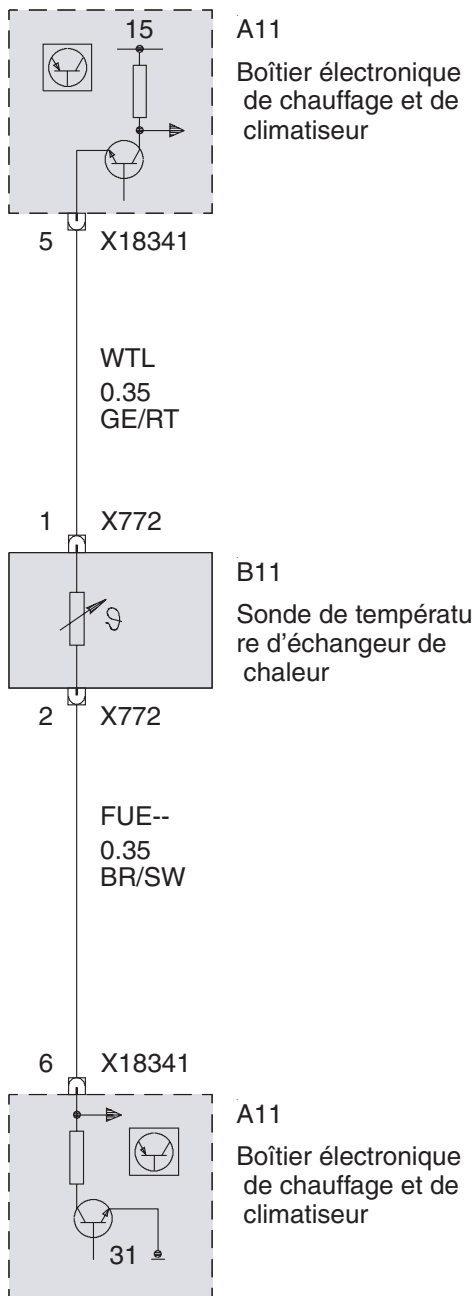

### Sonde de l'évaporateur

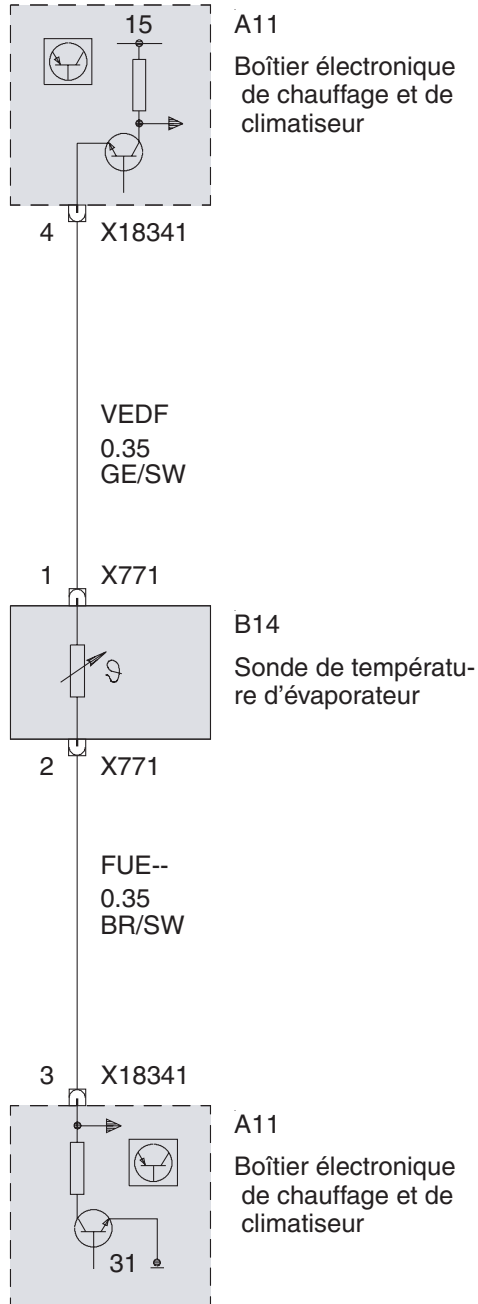

Capteur solaire (IHKA)

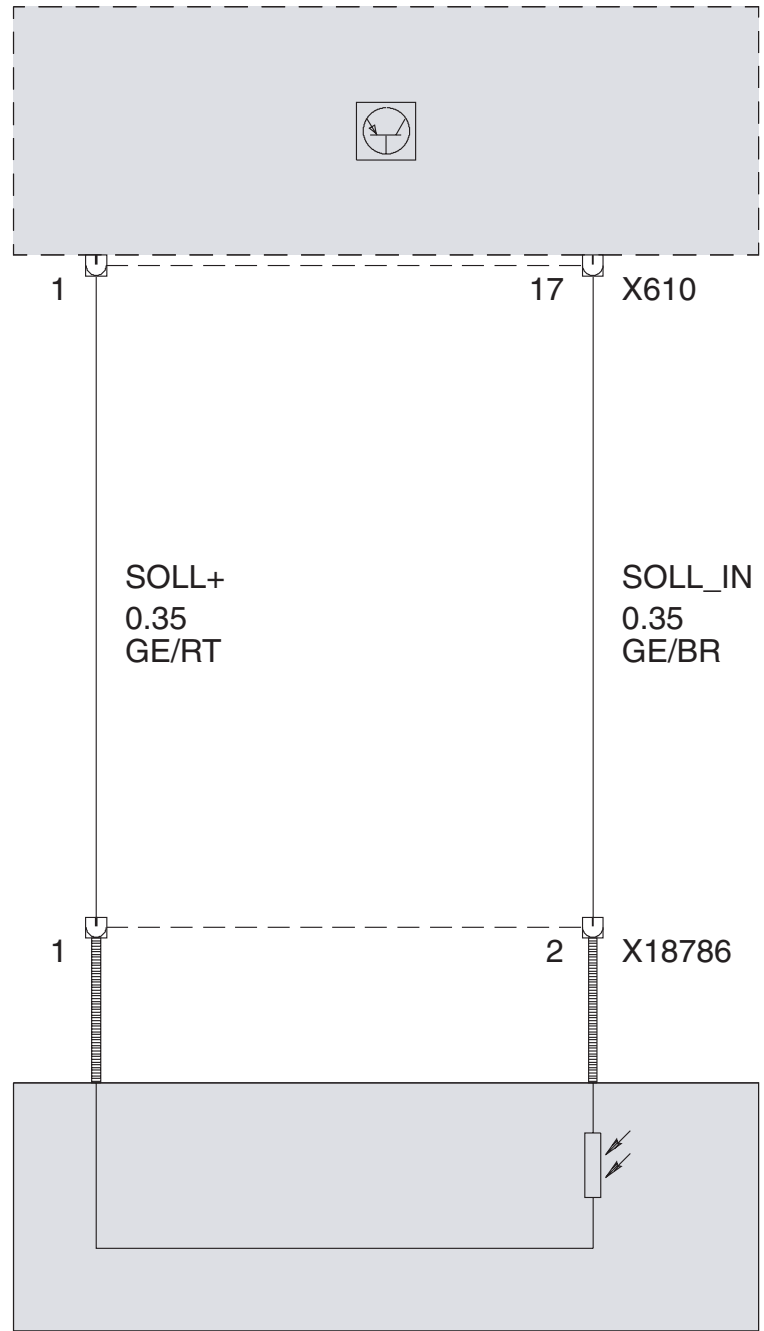

A11

Boîtier électronique  
de chauffage et de  
climatiseur

B66

Capteur solaire

Pompe à eau supplémentaire (avec IHKA / IHKR)

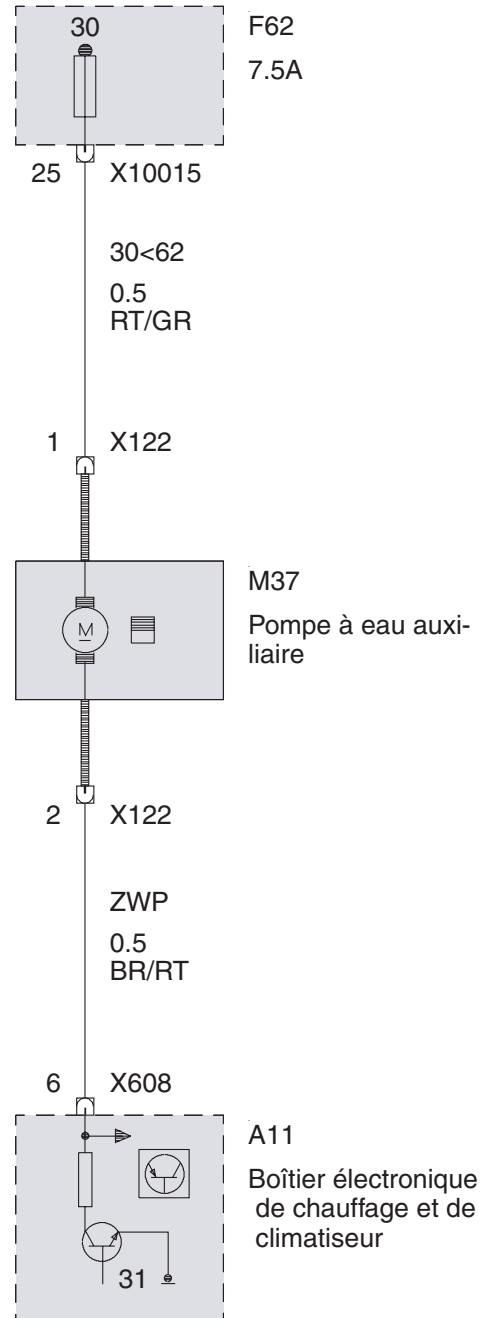



Pompe à eau additionnelle (Commande du chauffage)

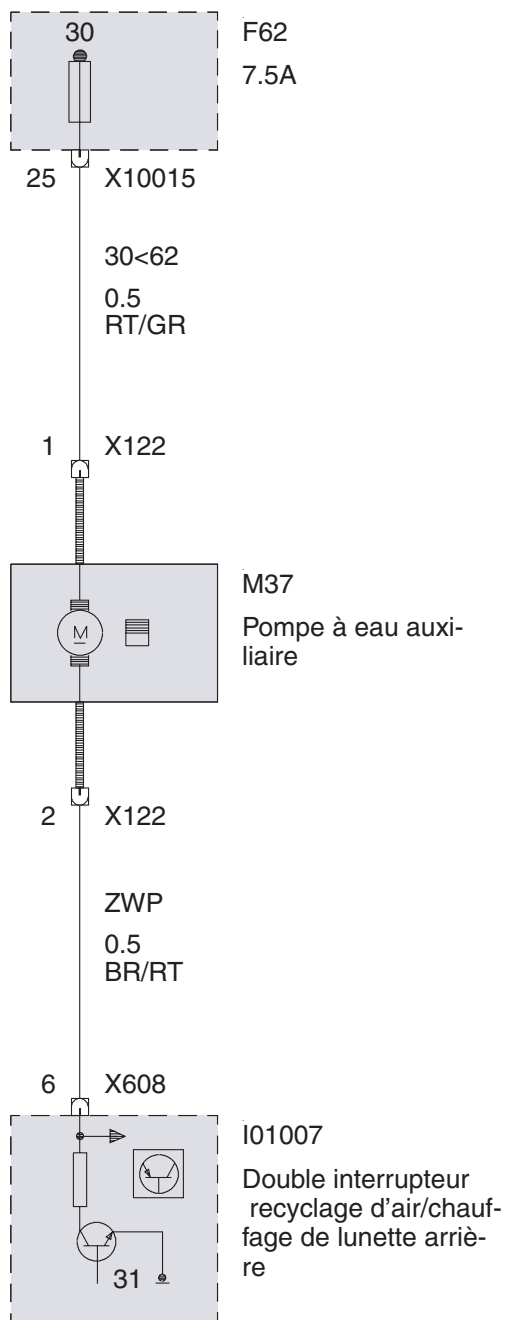

Vanne d'eau (avec IHKA / IHKR)

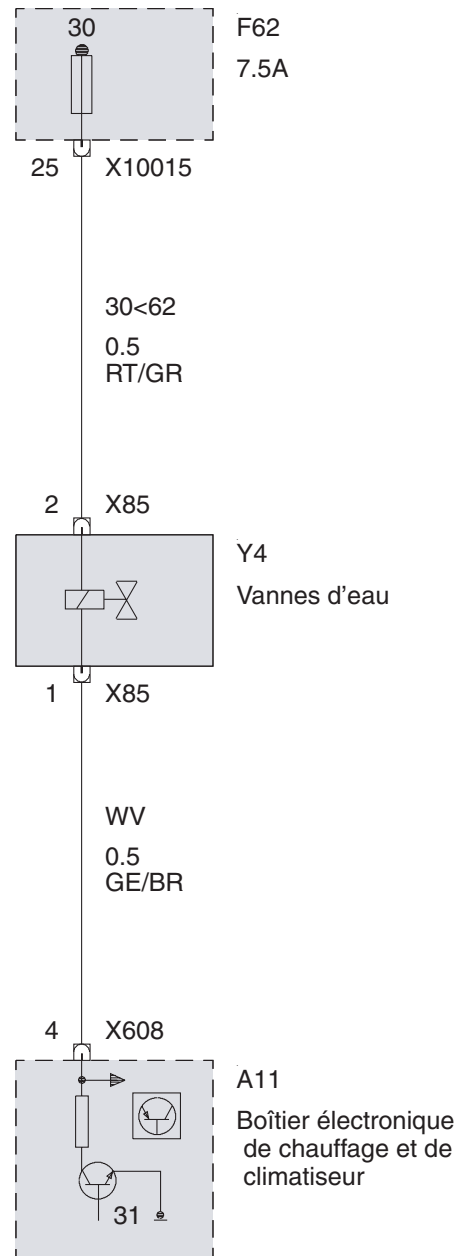

Connecteur X10116

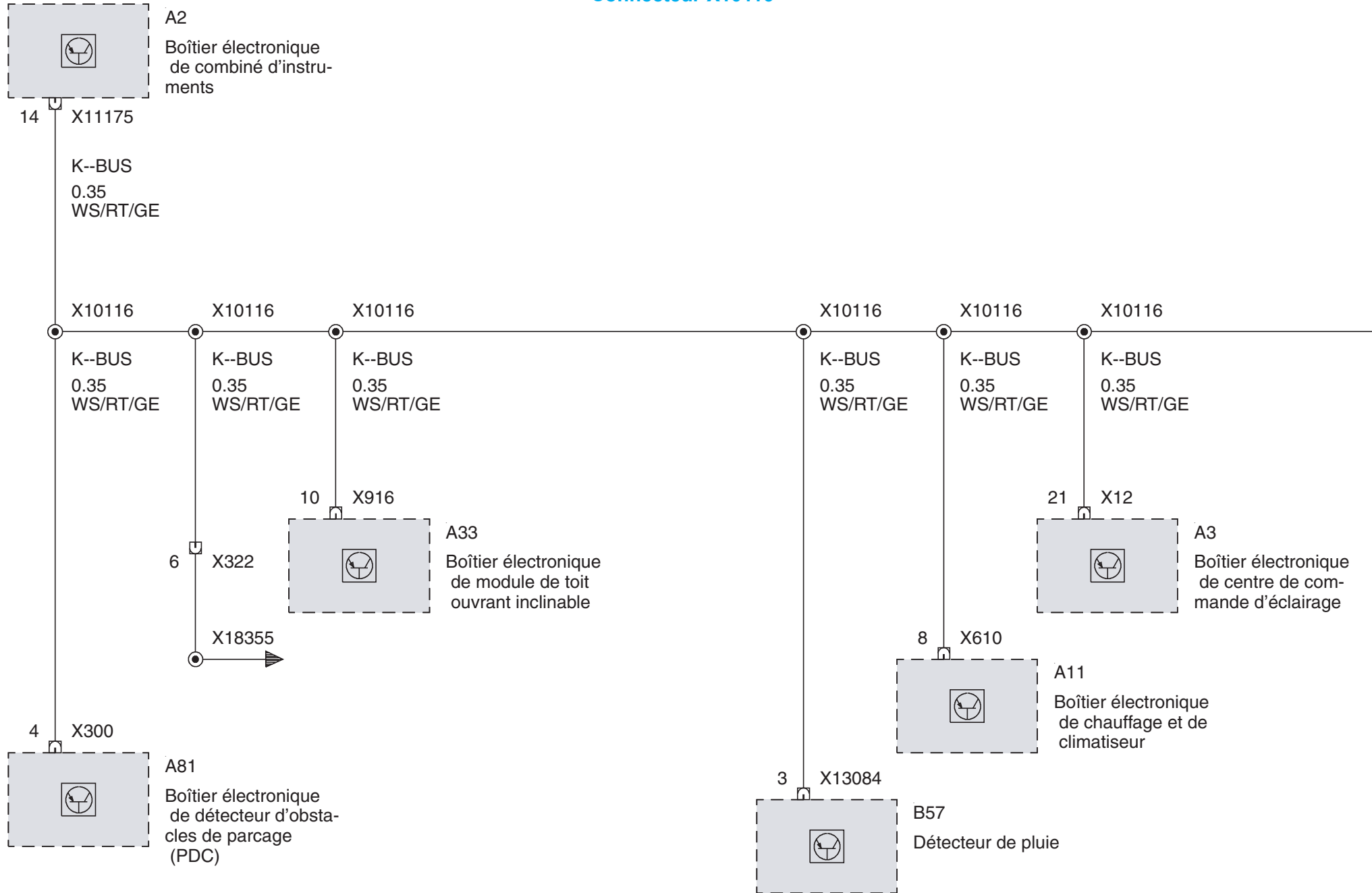

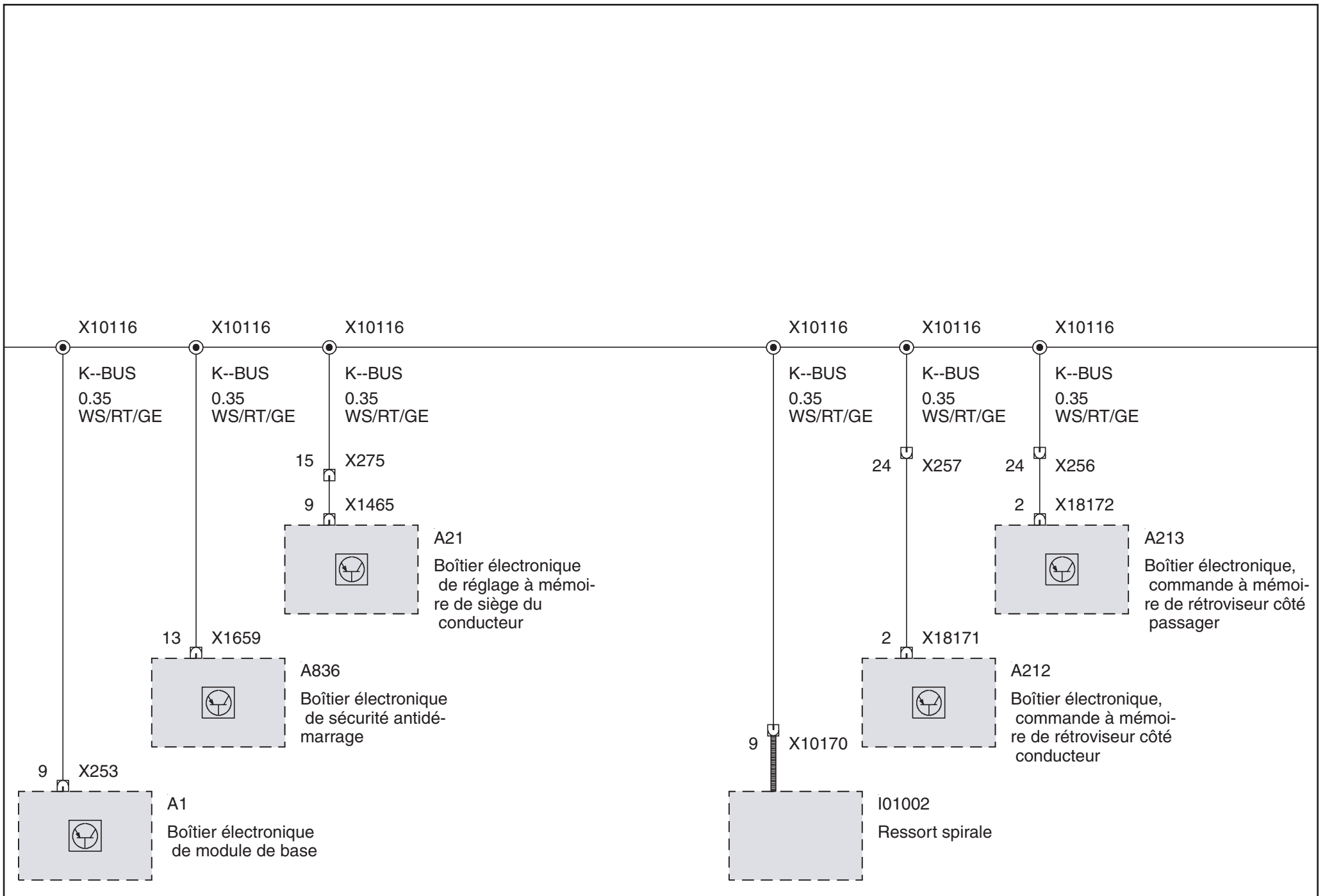

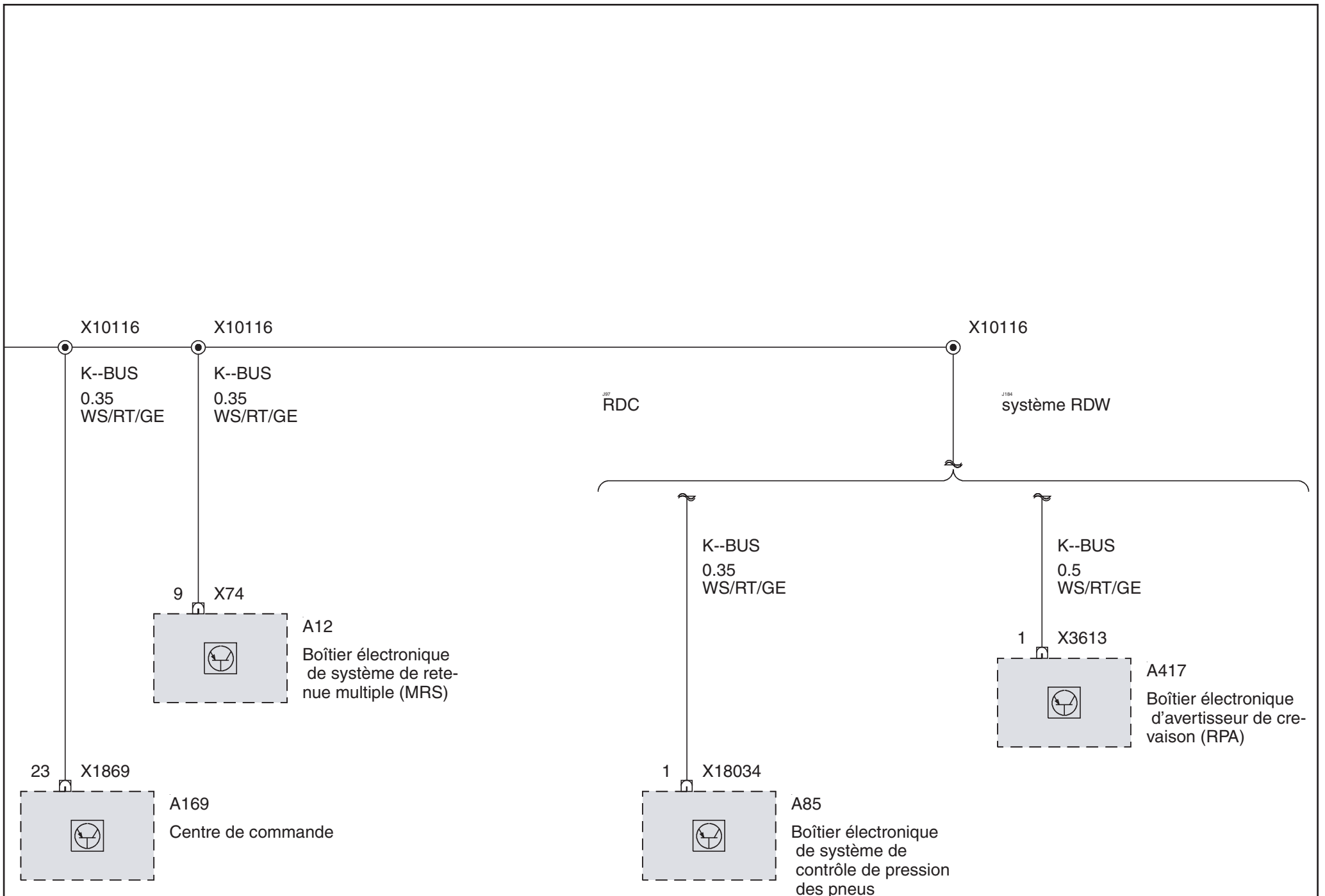

Commande du compresseur (DME Electronique moteur ME9)

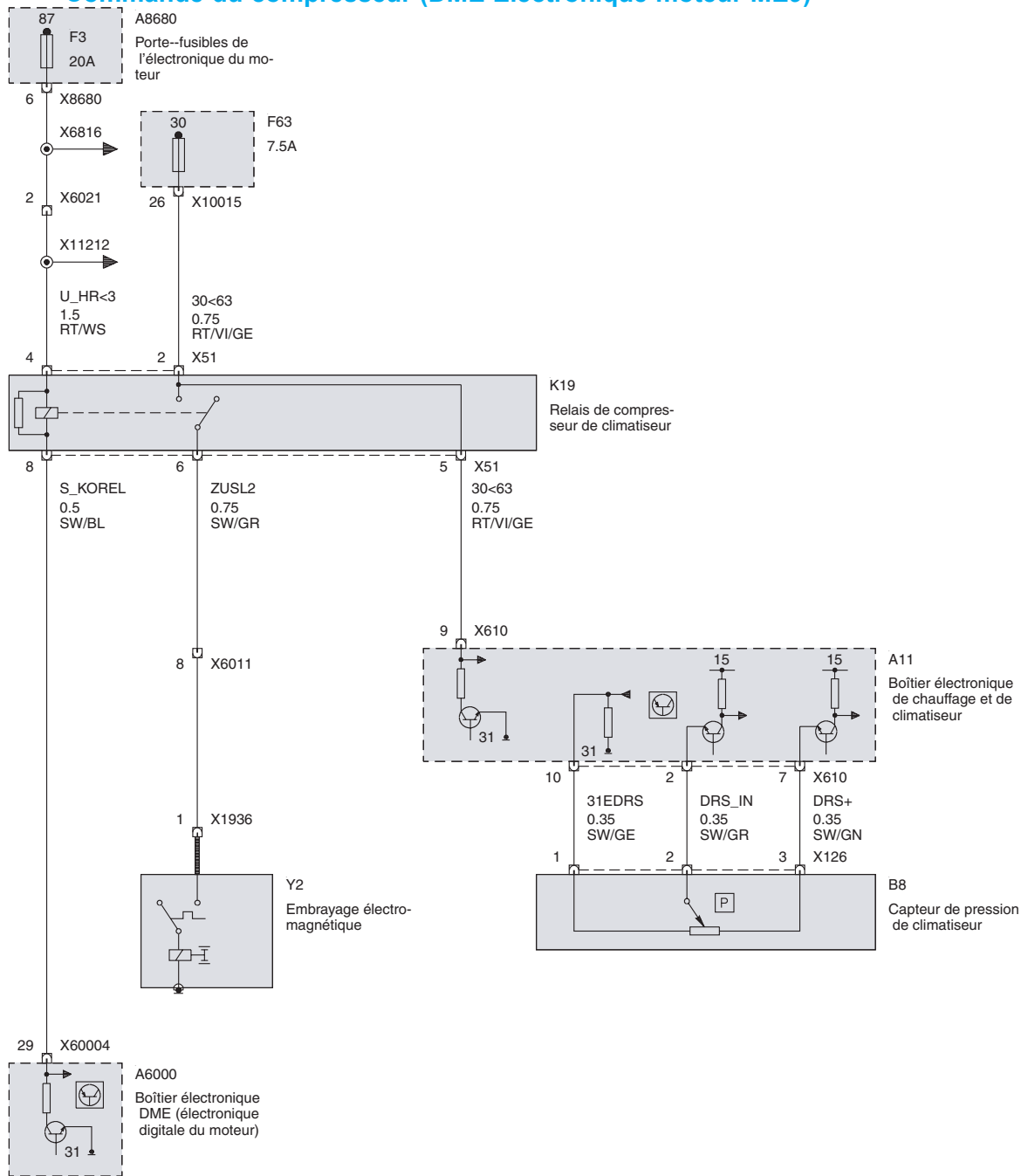

Commande du compresseur (DDE Electronique Diesel DDE50)

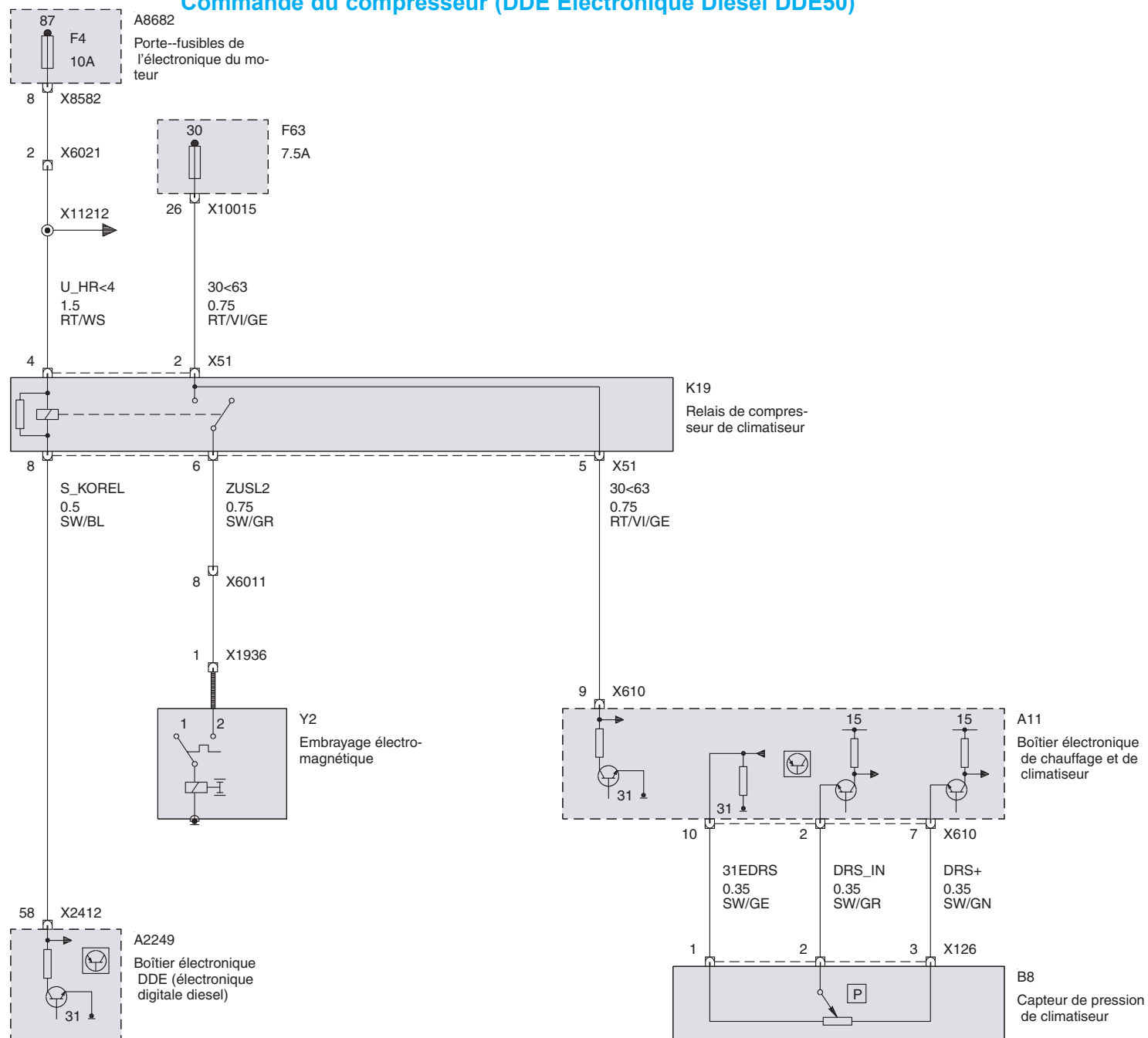

Commande du compresseur (DME Electronique moteur MS43)

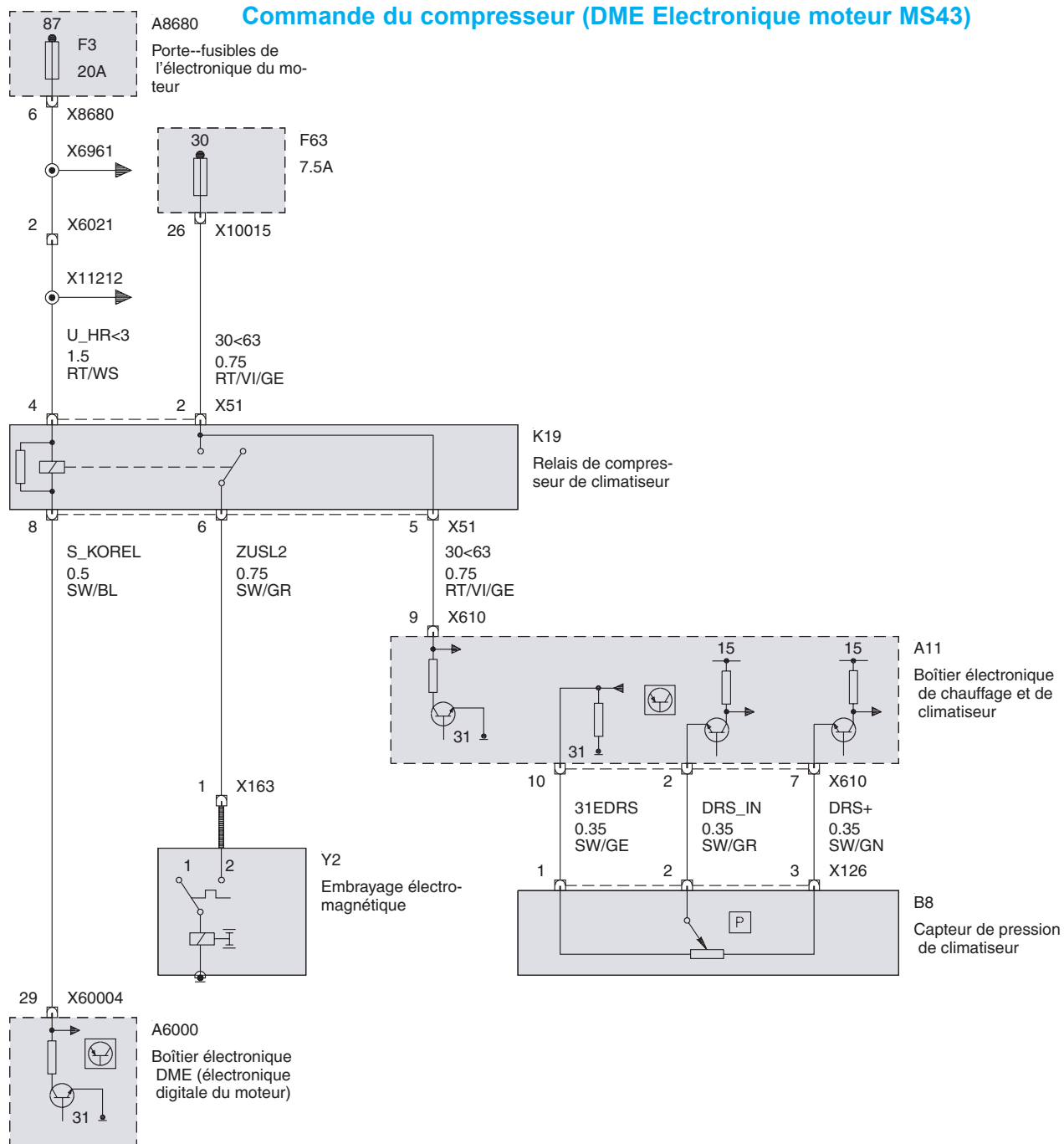



Température de liquide de refroidissement/ventilateur électrique (DME Electronique moteur MS43 ou ME9, jusque 2003\_03)

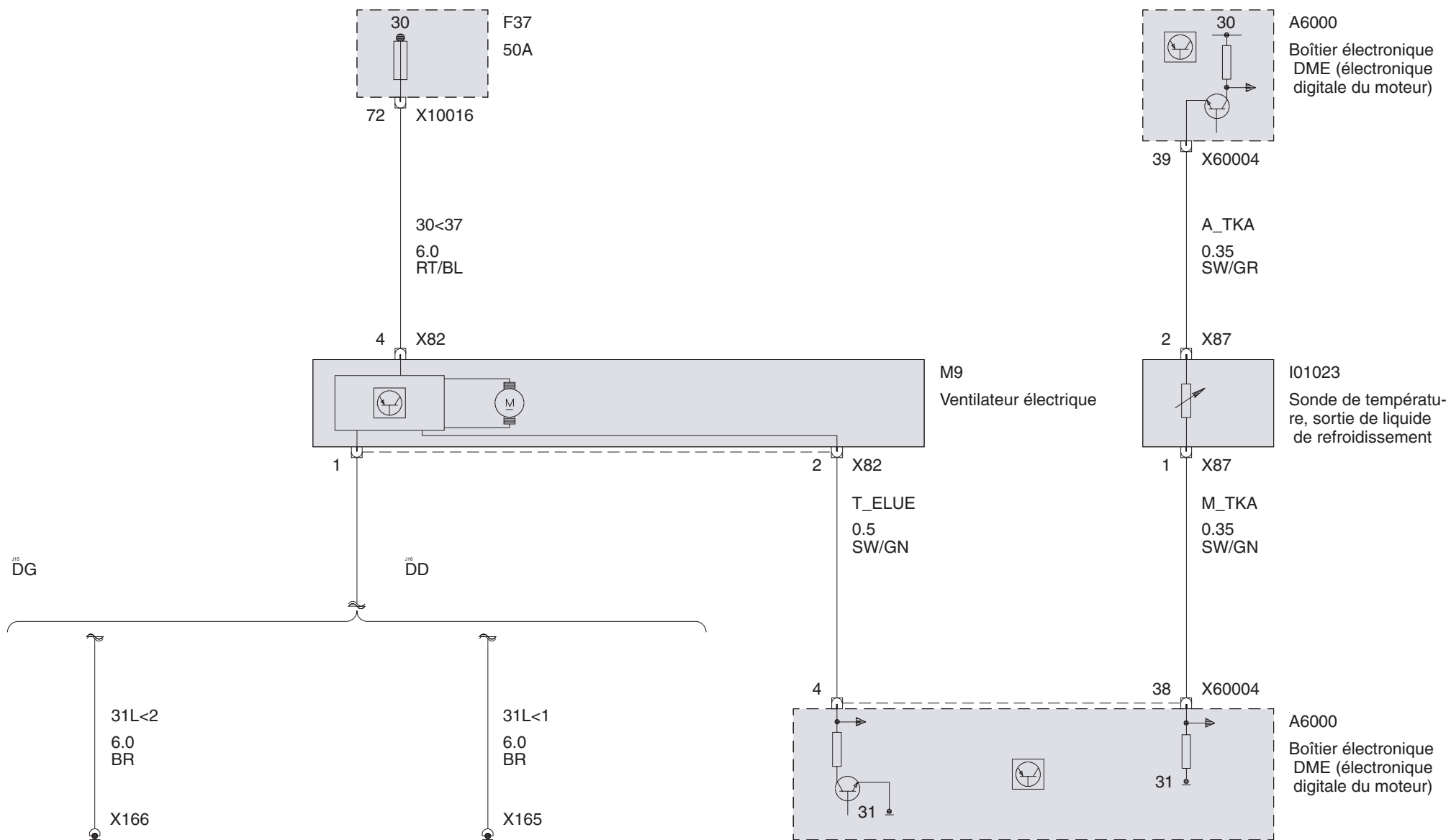

Température de liquide de refroidissement/ventilateur électrique ((Berline ou Compact ou Touring ) DME Electronique moteur MS43 ou ME9 à partir de 2003\_03)

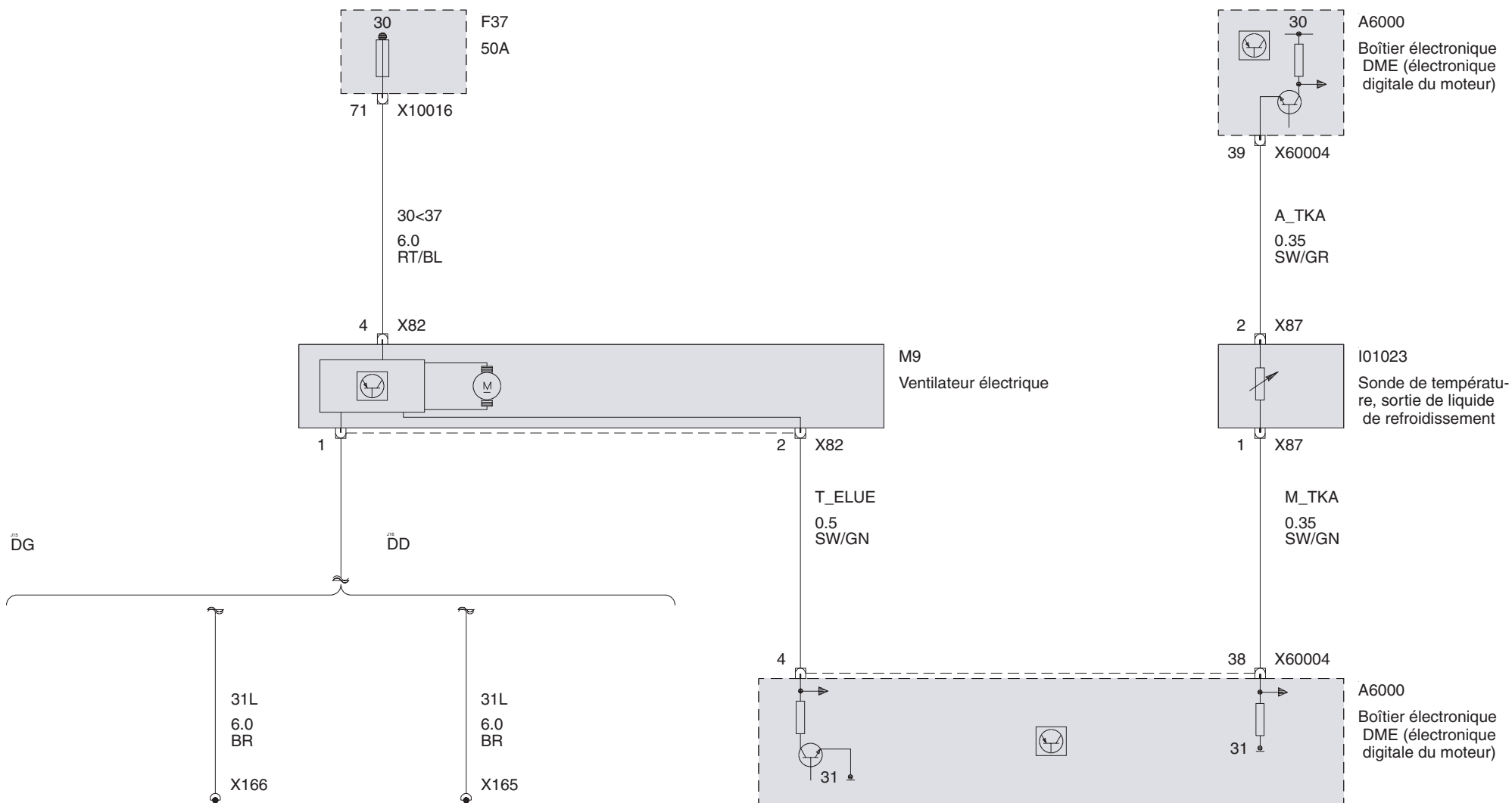

Température de liquide de refroidissement/ventilateur électrique (( Coupé ou Cabriolet ) DME Electronique moteur MS43 ou ME9 à partir de 2003\_03)

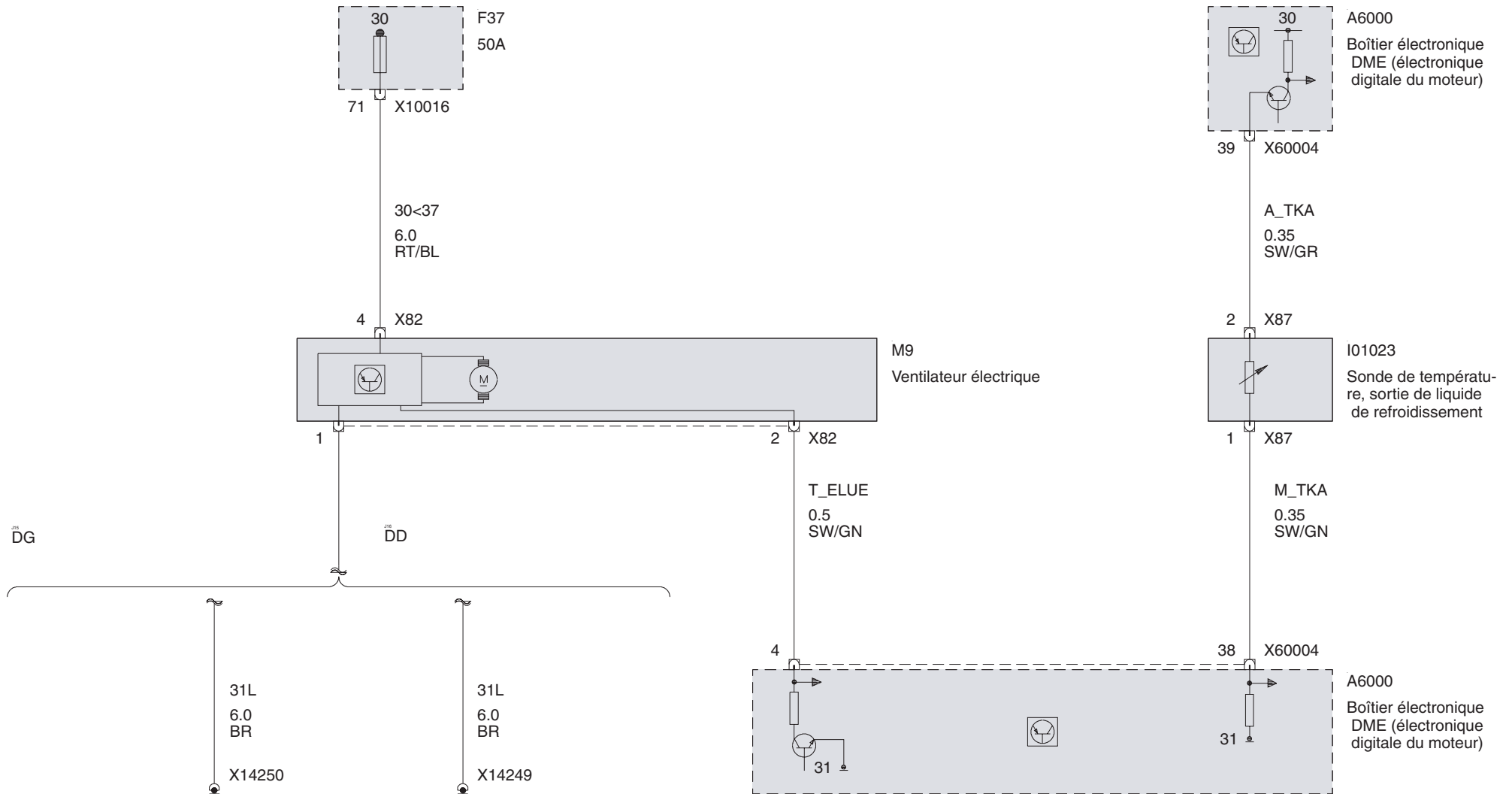

Température de liquide de refroidissement/ventilateur électrique (Diesel)

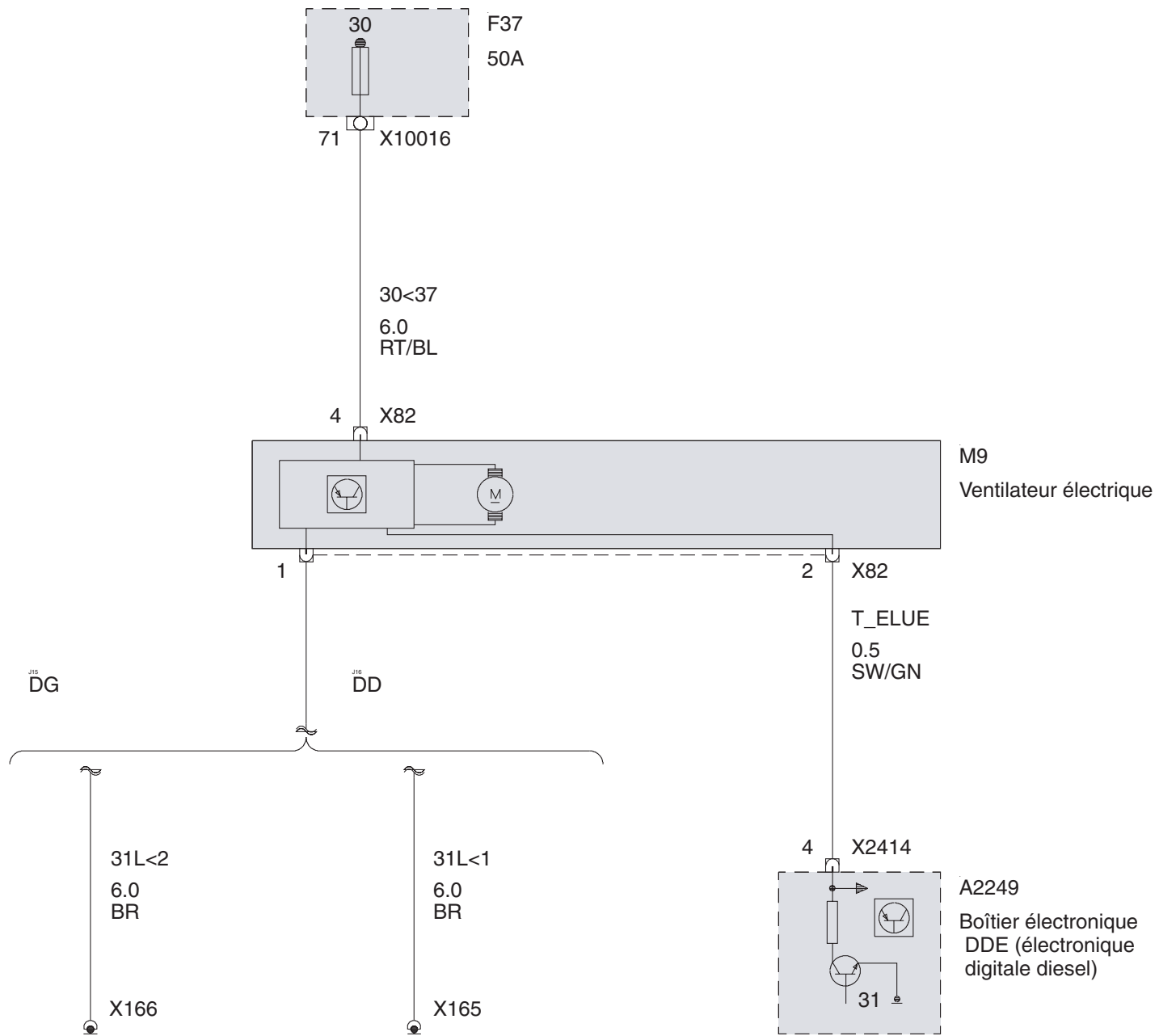

Chauffage lunette arrière (Berline ou Coupé)

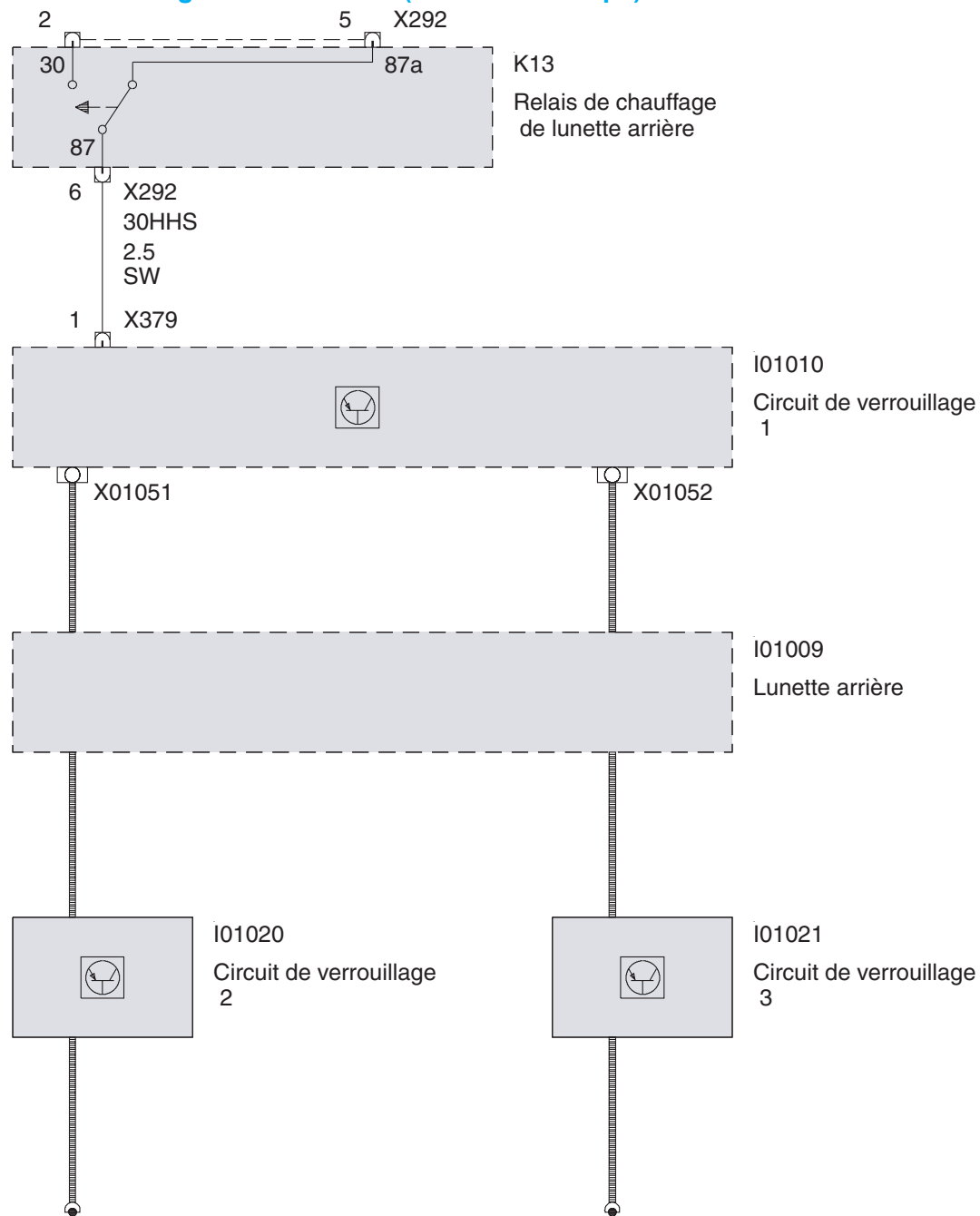

Chauffage lunette arrière (Touring)

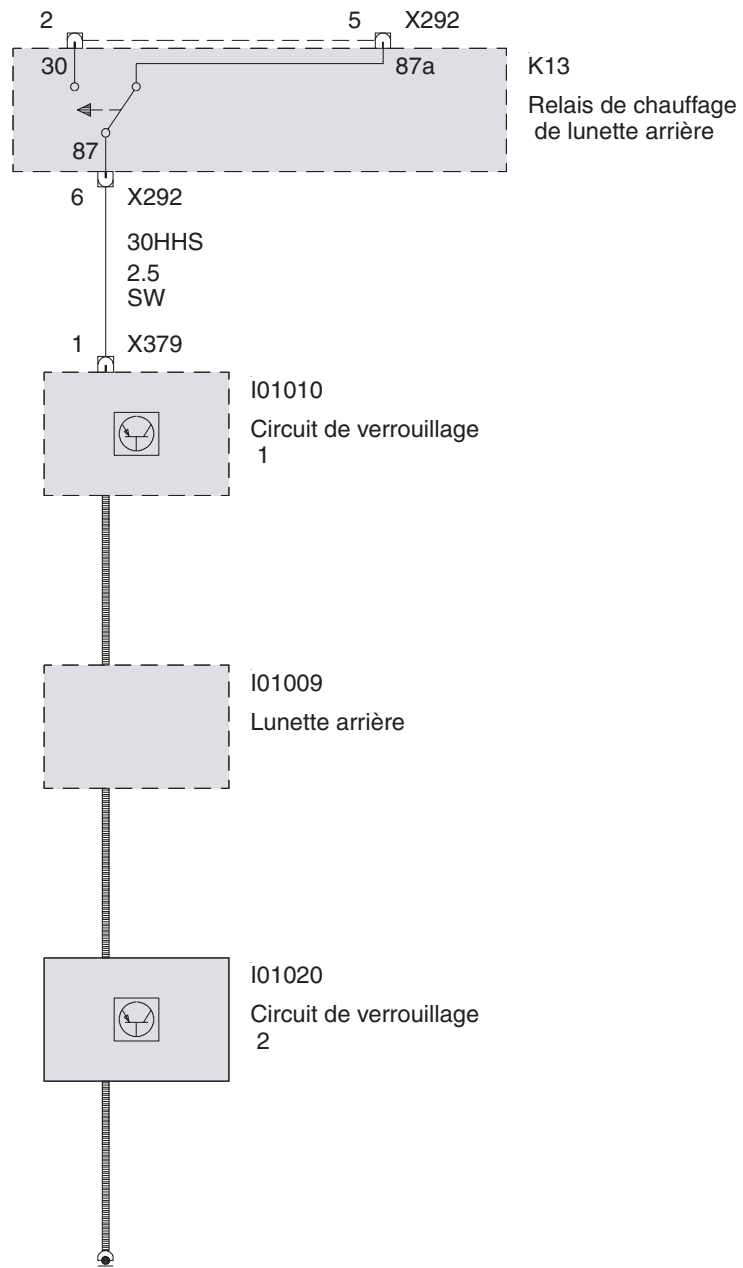

Chauffage lunette arrière (Compact)

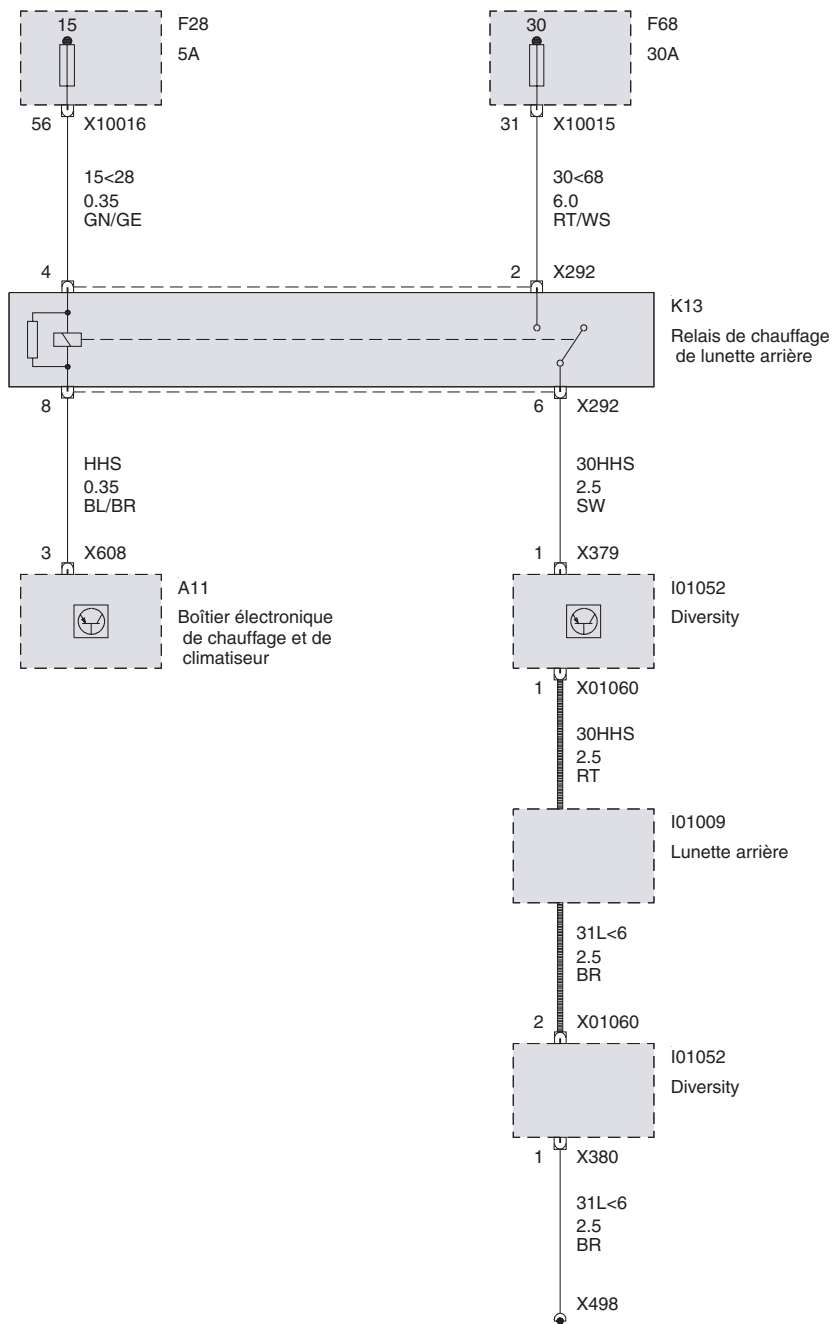

## Fonctions de retenue et de protection

### Fonctions de retenue (avec MRS Système de retenue multiple III/IV)

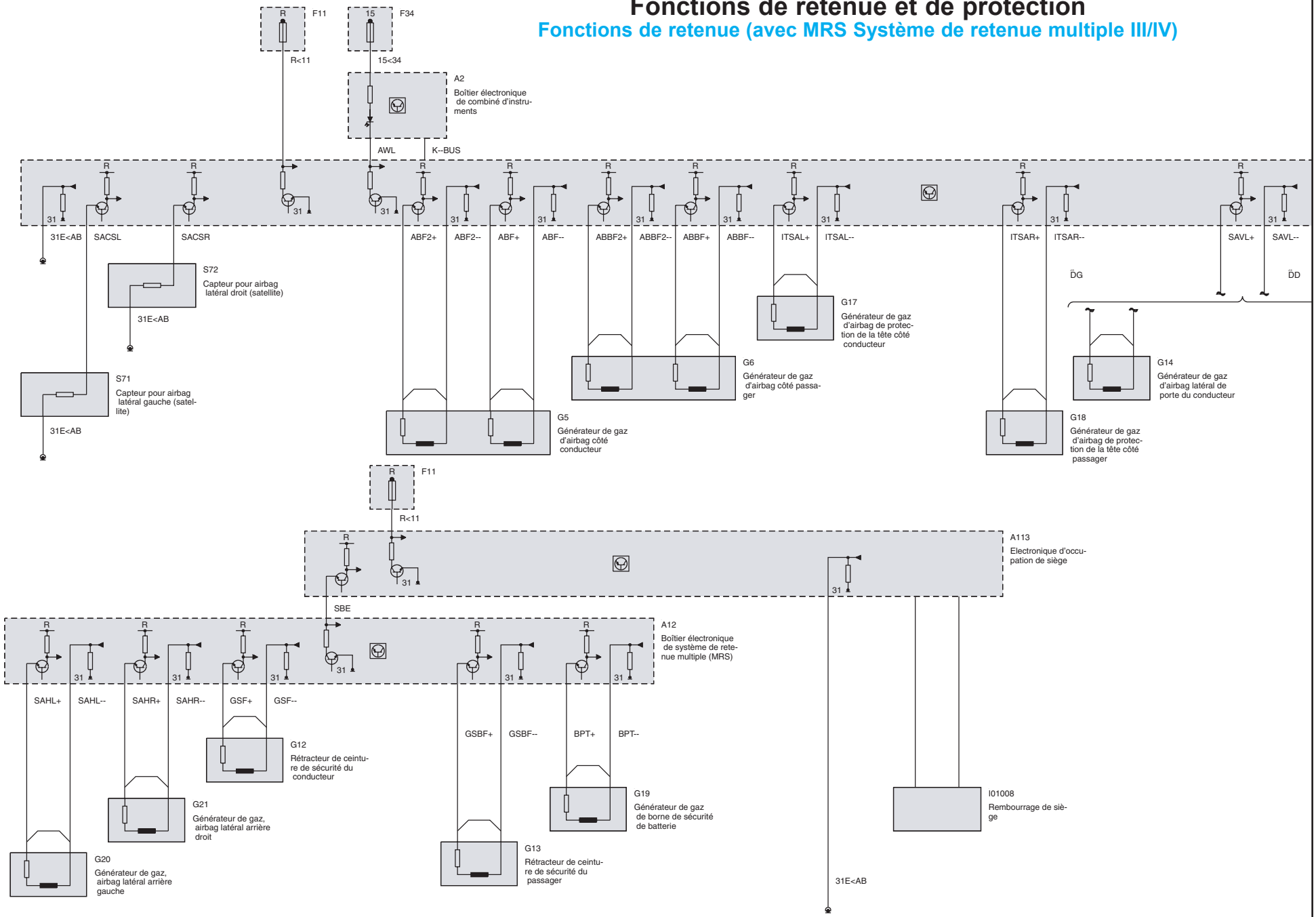



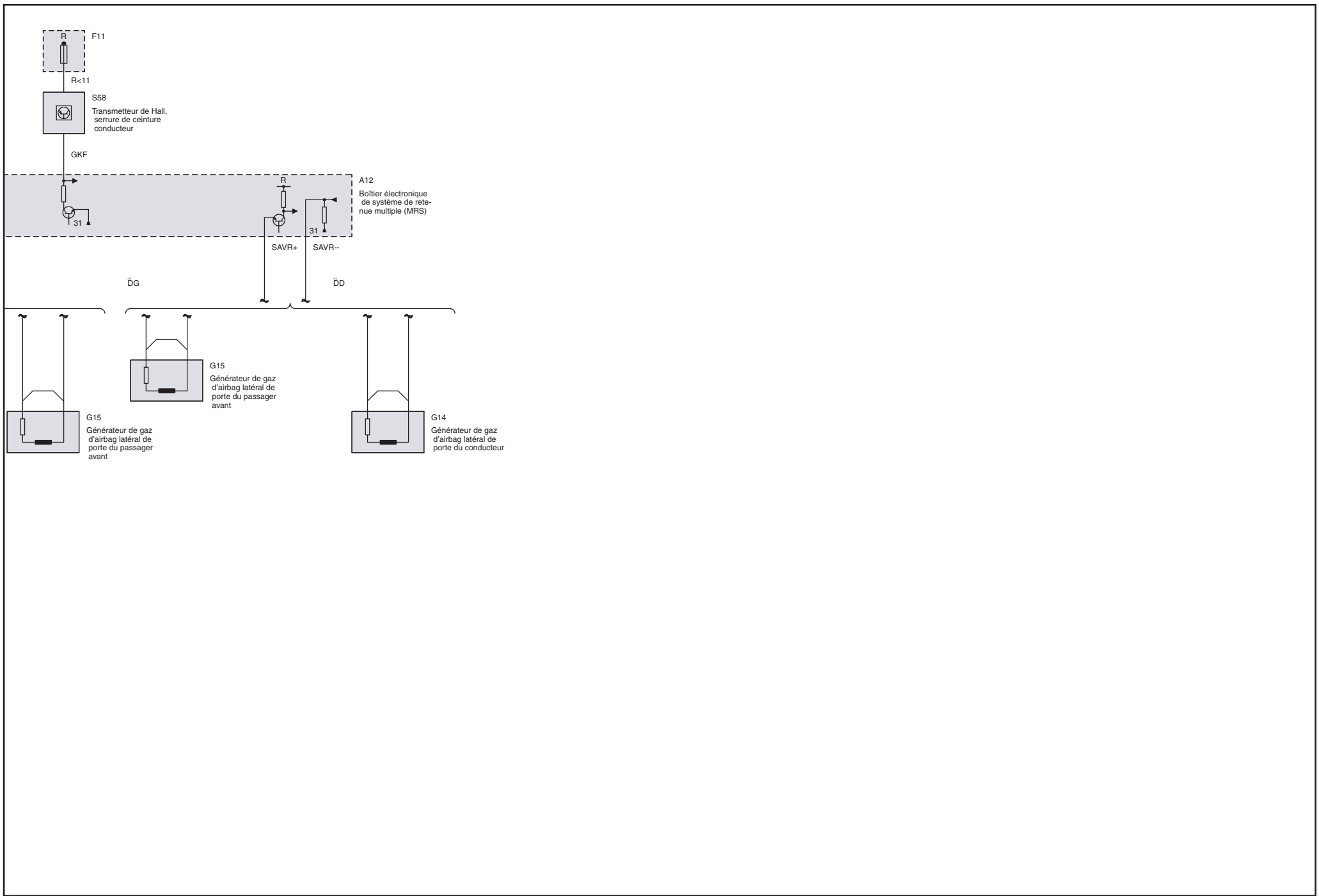

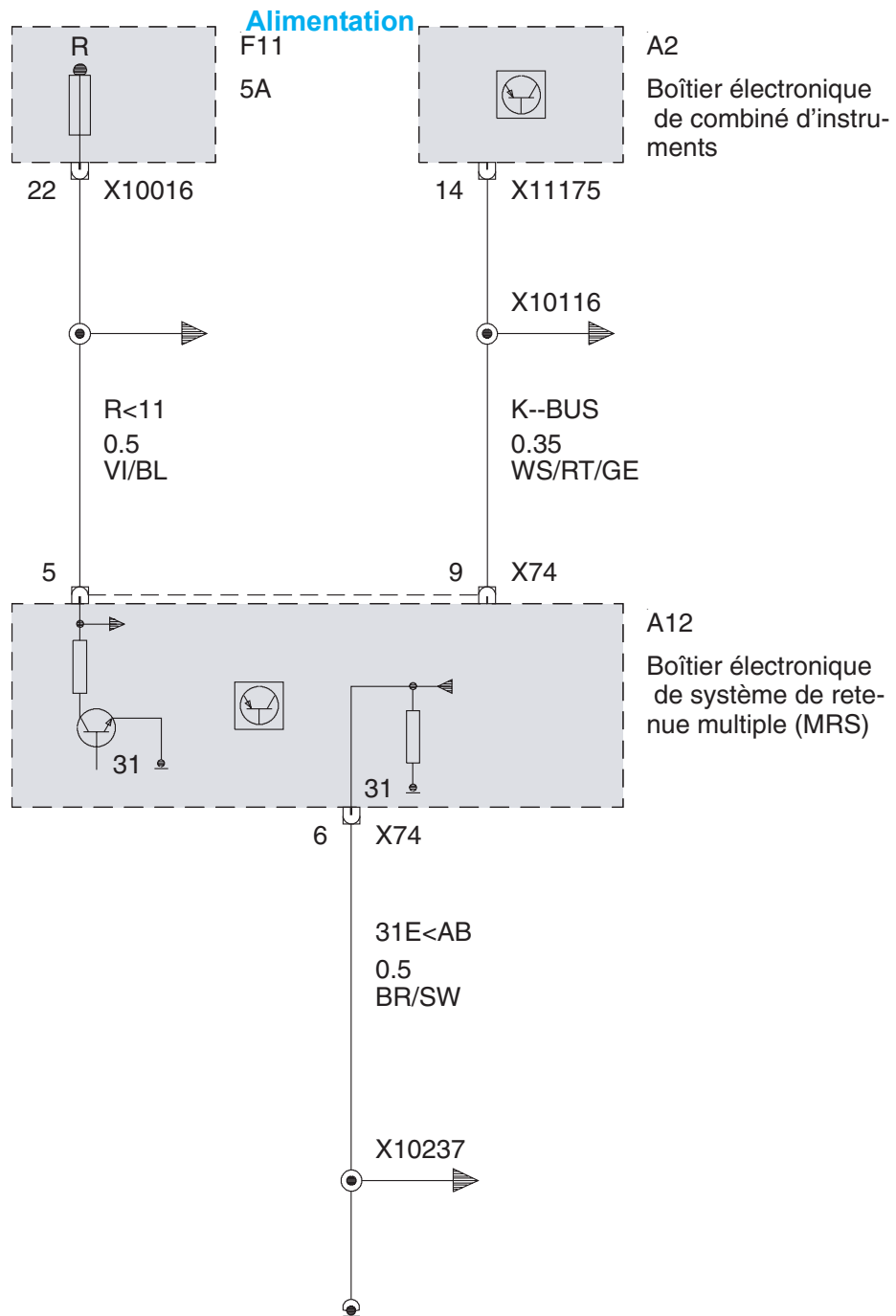

Voyant airbag

Connecteur X10116 (Berline ou Touring)

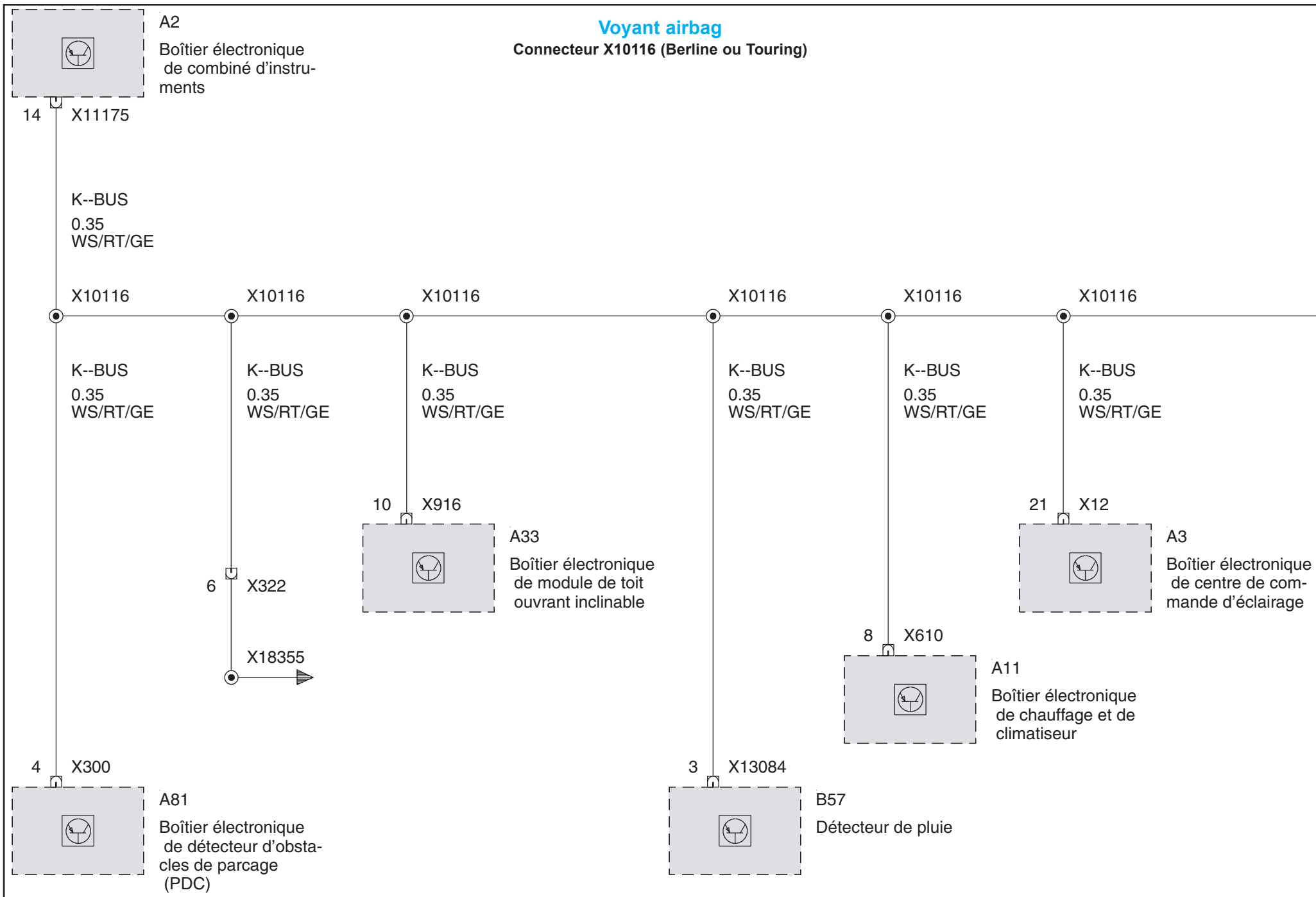

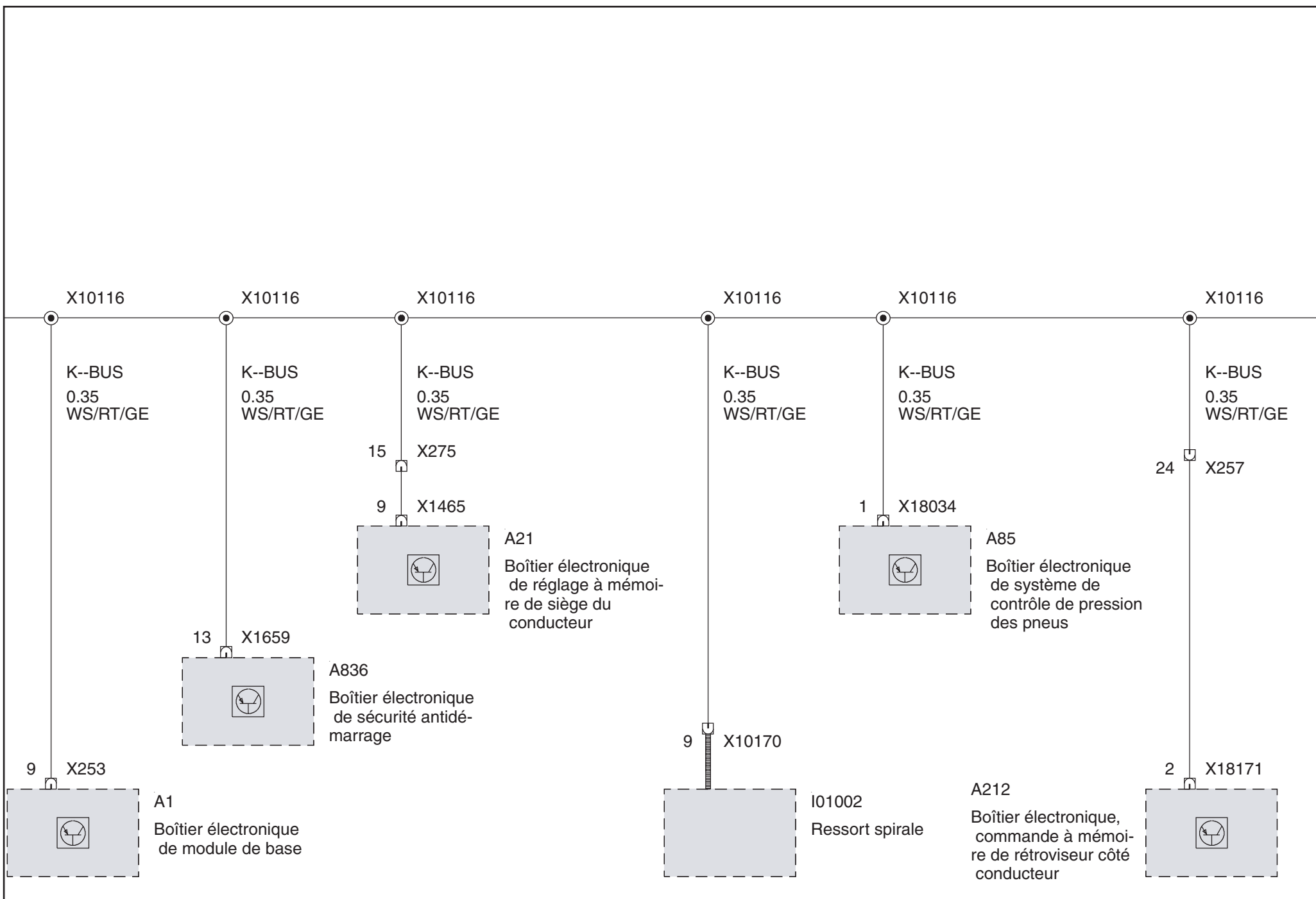

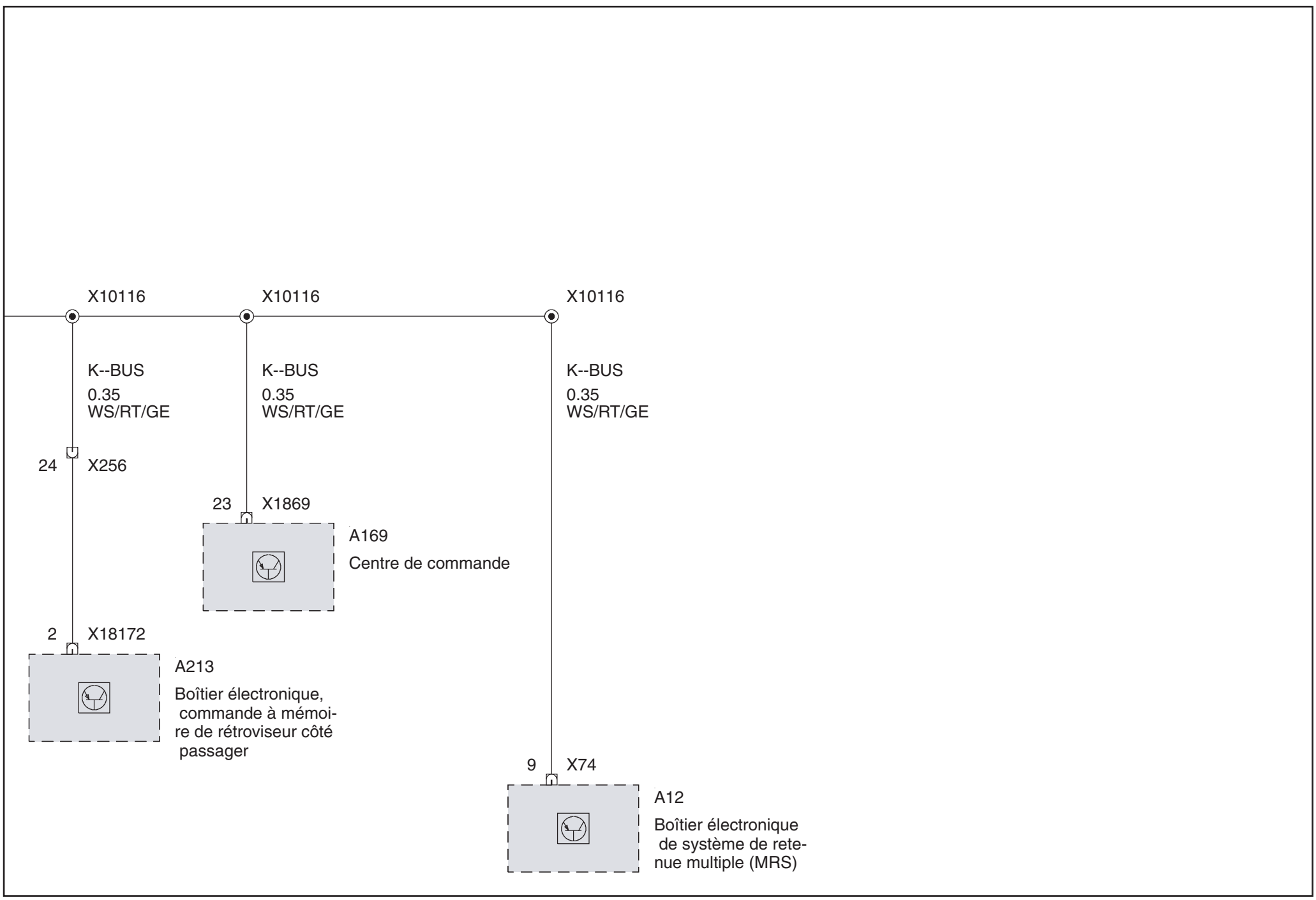

Connecteur X10116 (Coupé ou Cabriolet ou Compact)

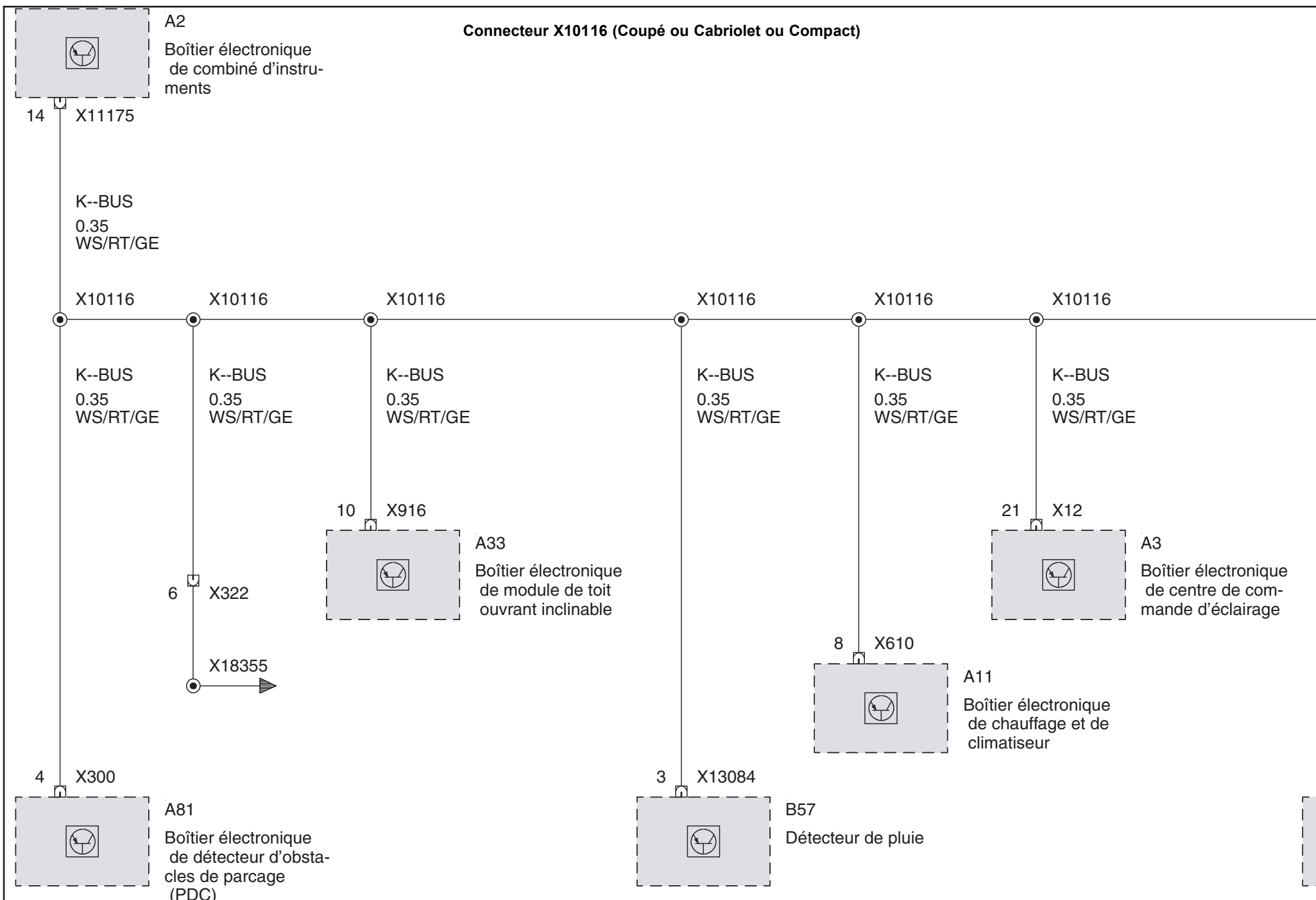

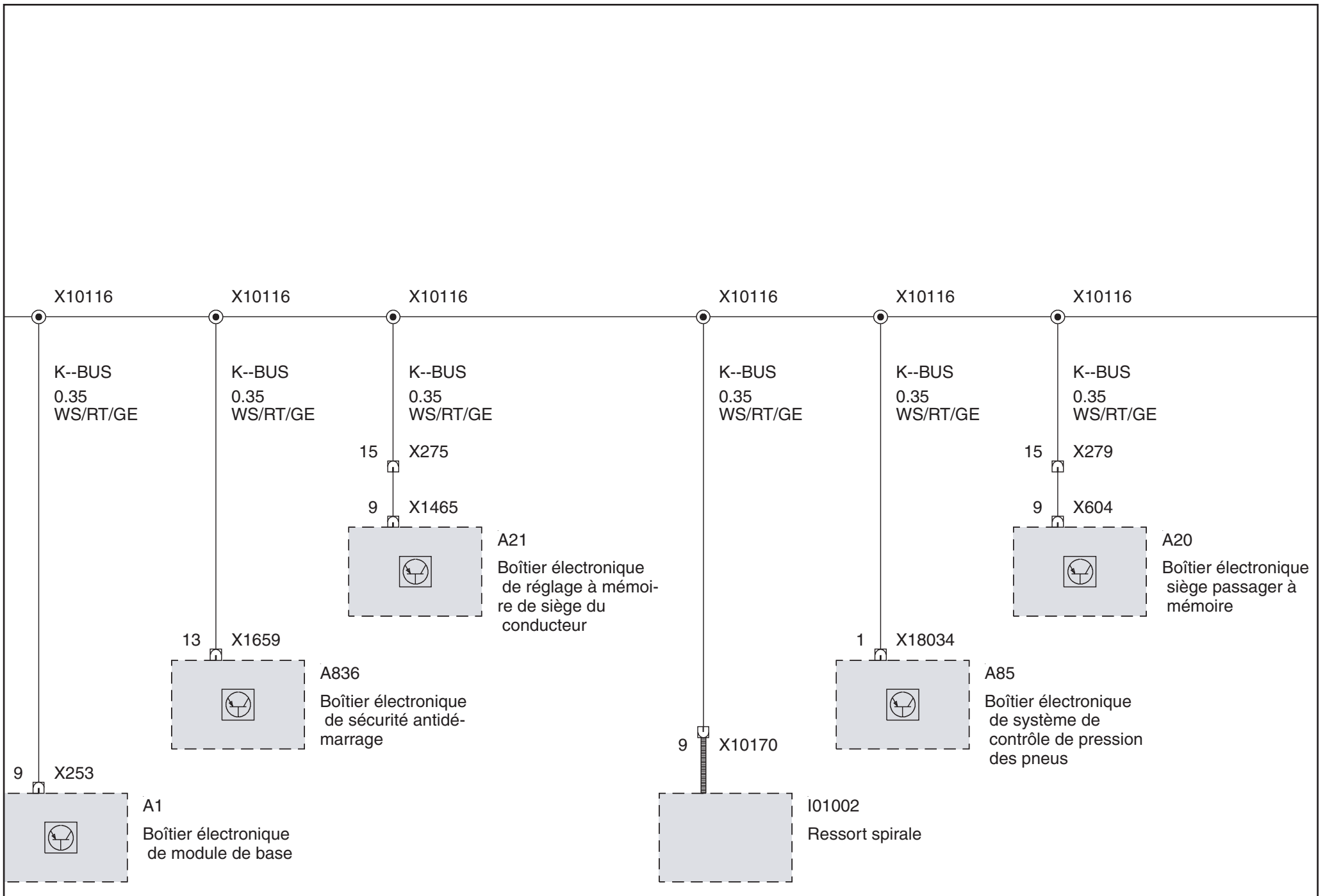

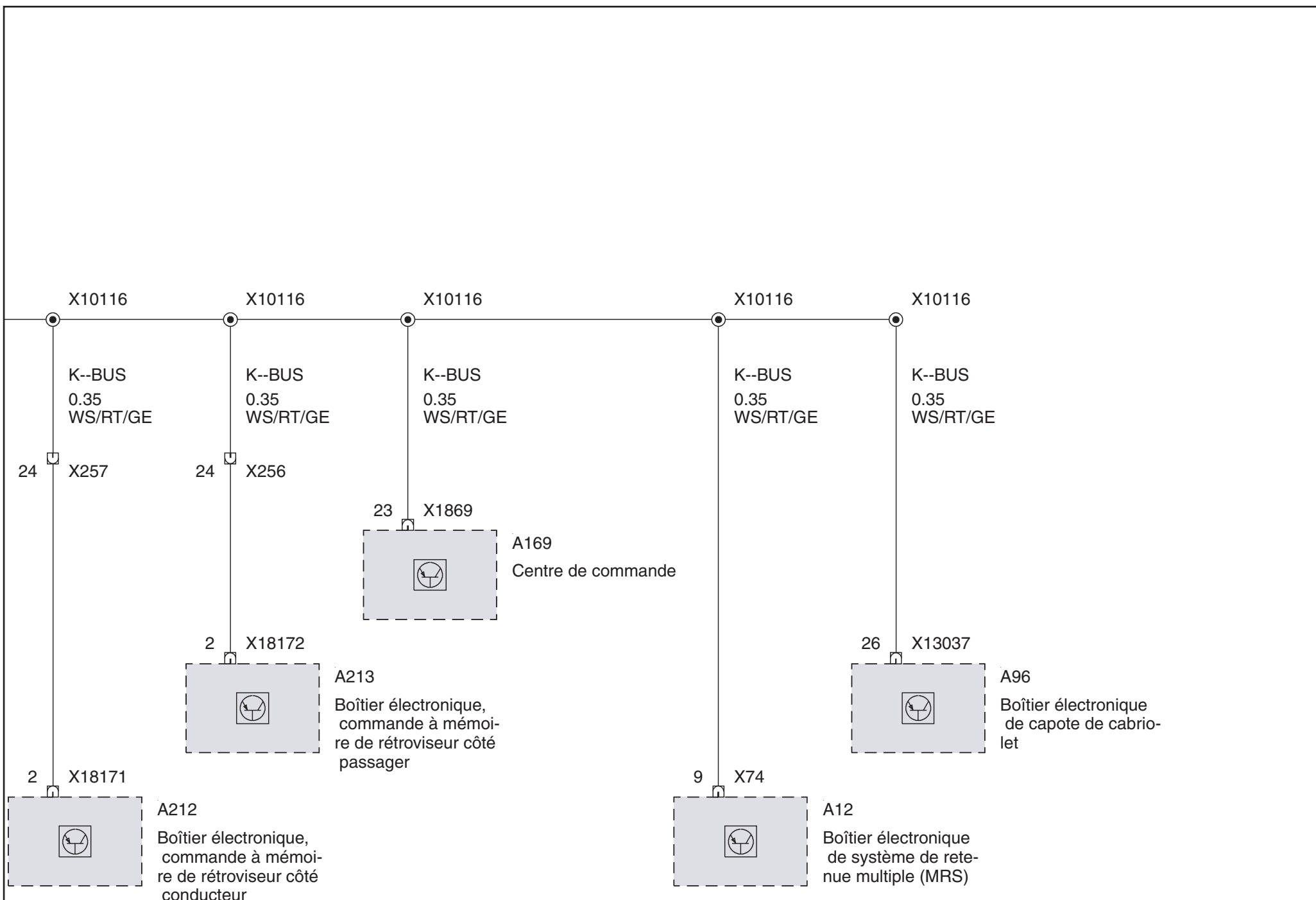



Capteur frontal airbag latéral

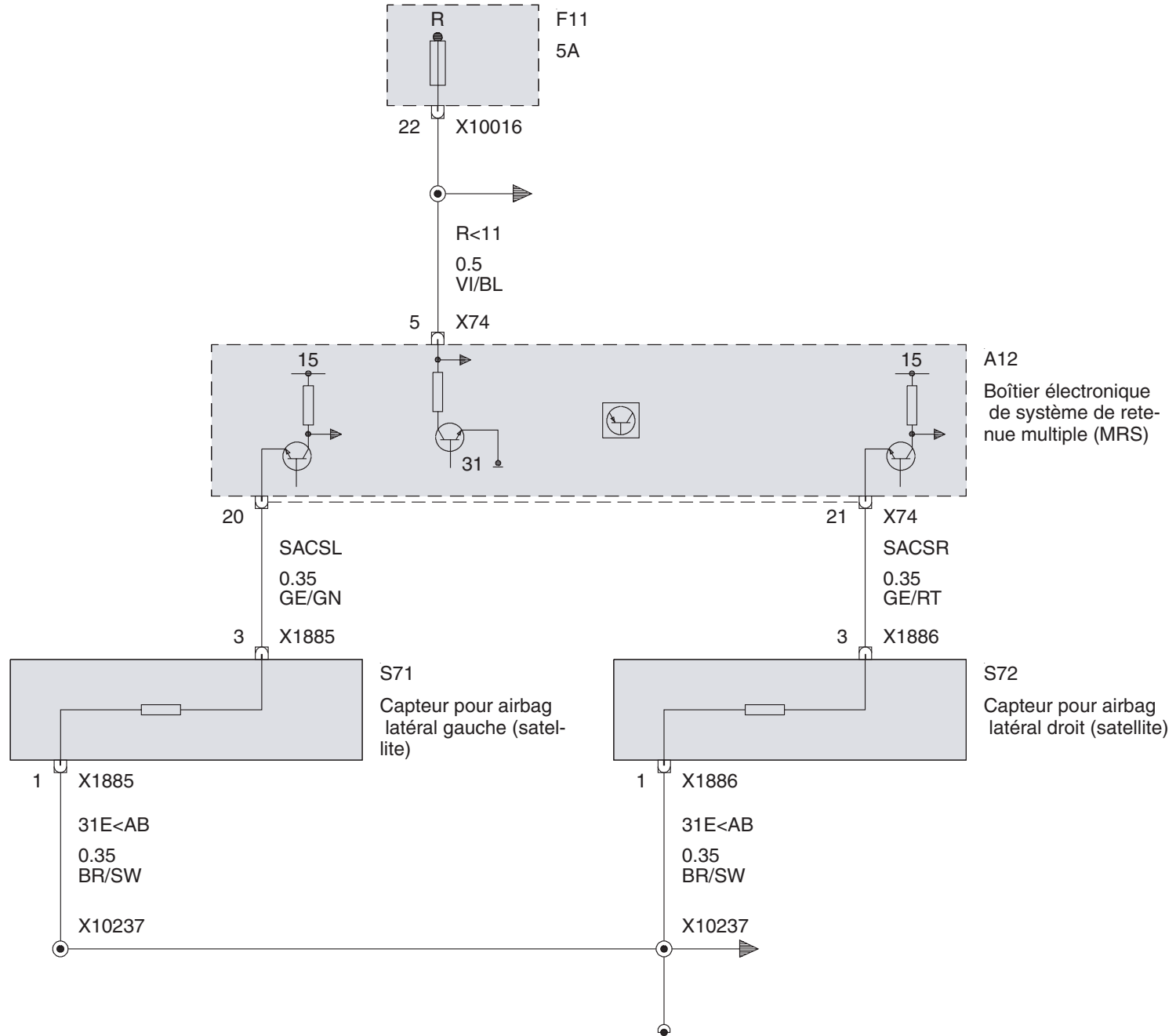

**Airbags**  
Airbags frontaux

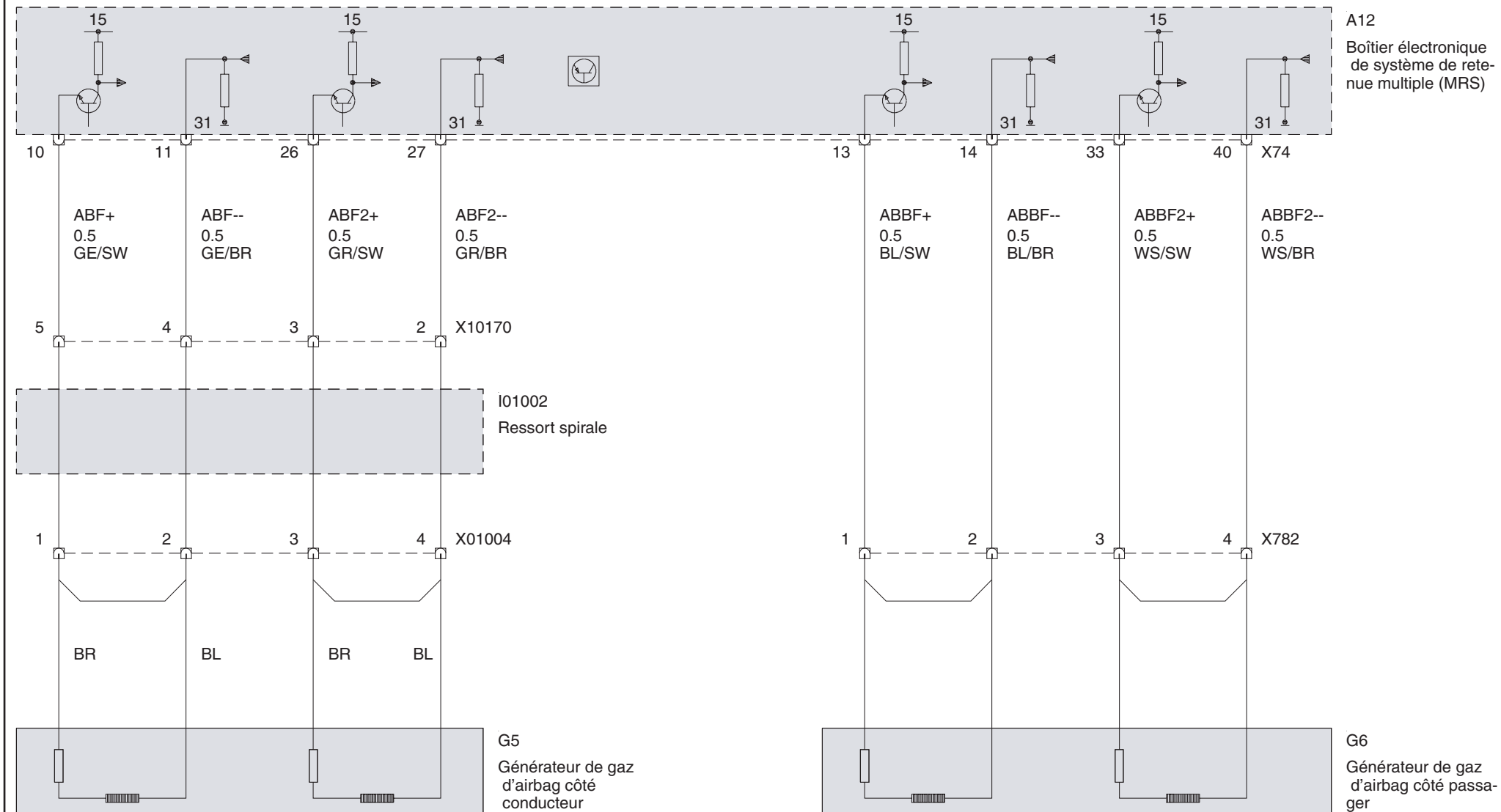

Airbag latéral de protection de la tête (ITS)

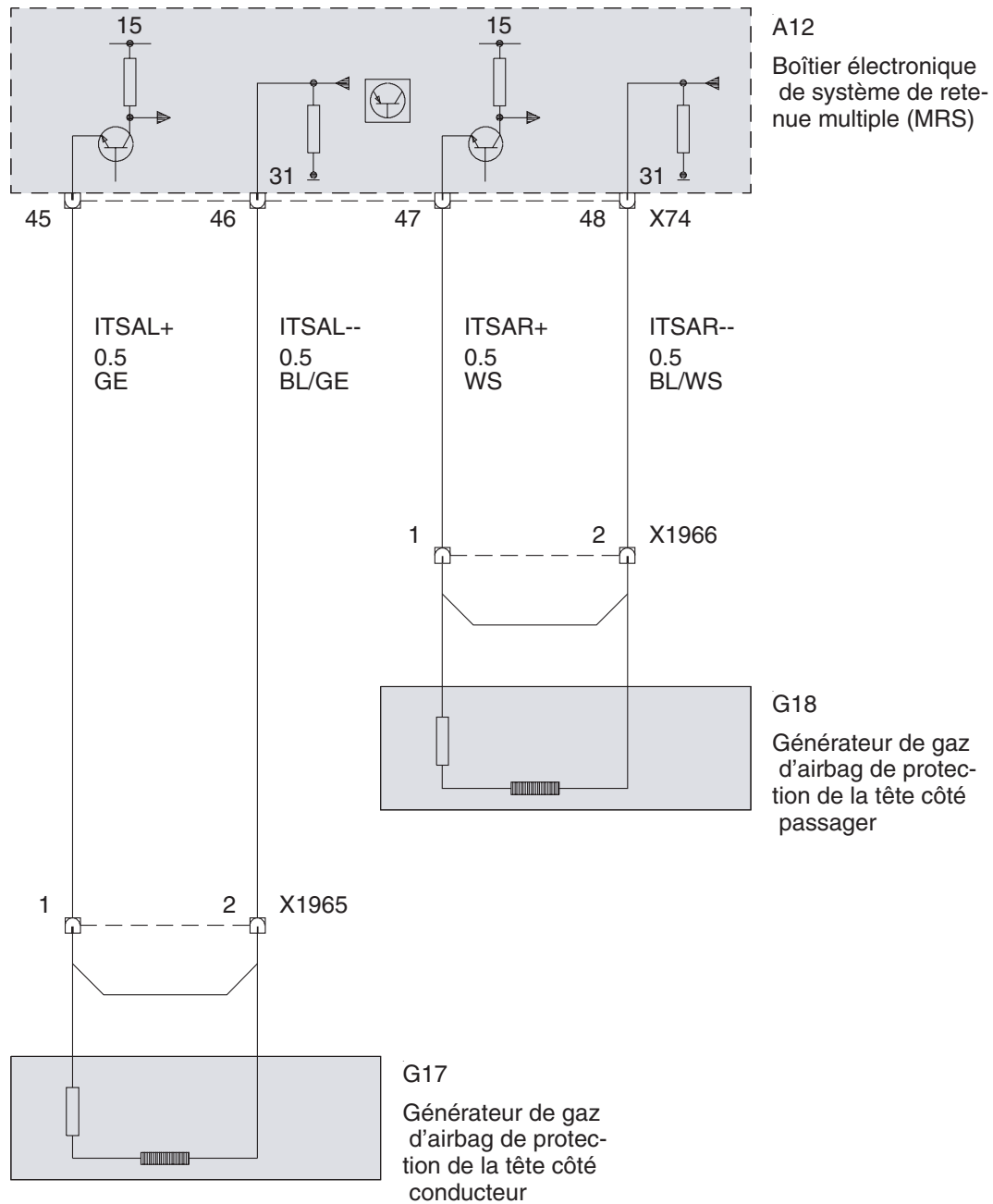

Airbag latéral avant

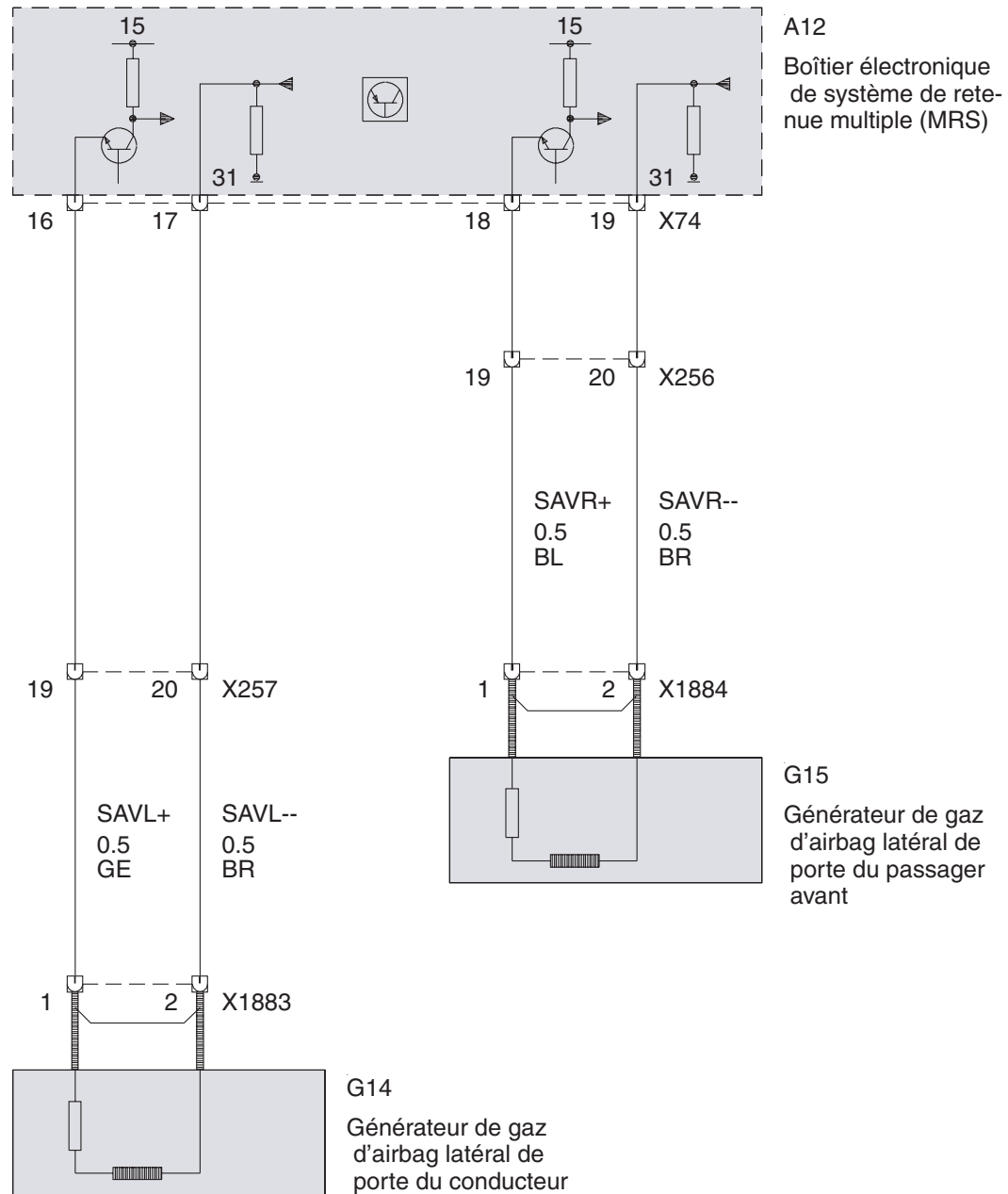

Airbag latéral arrière ( Berline ou Touring)

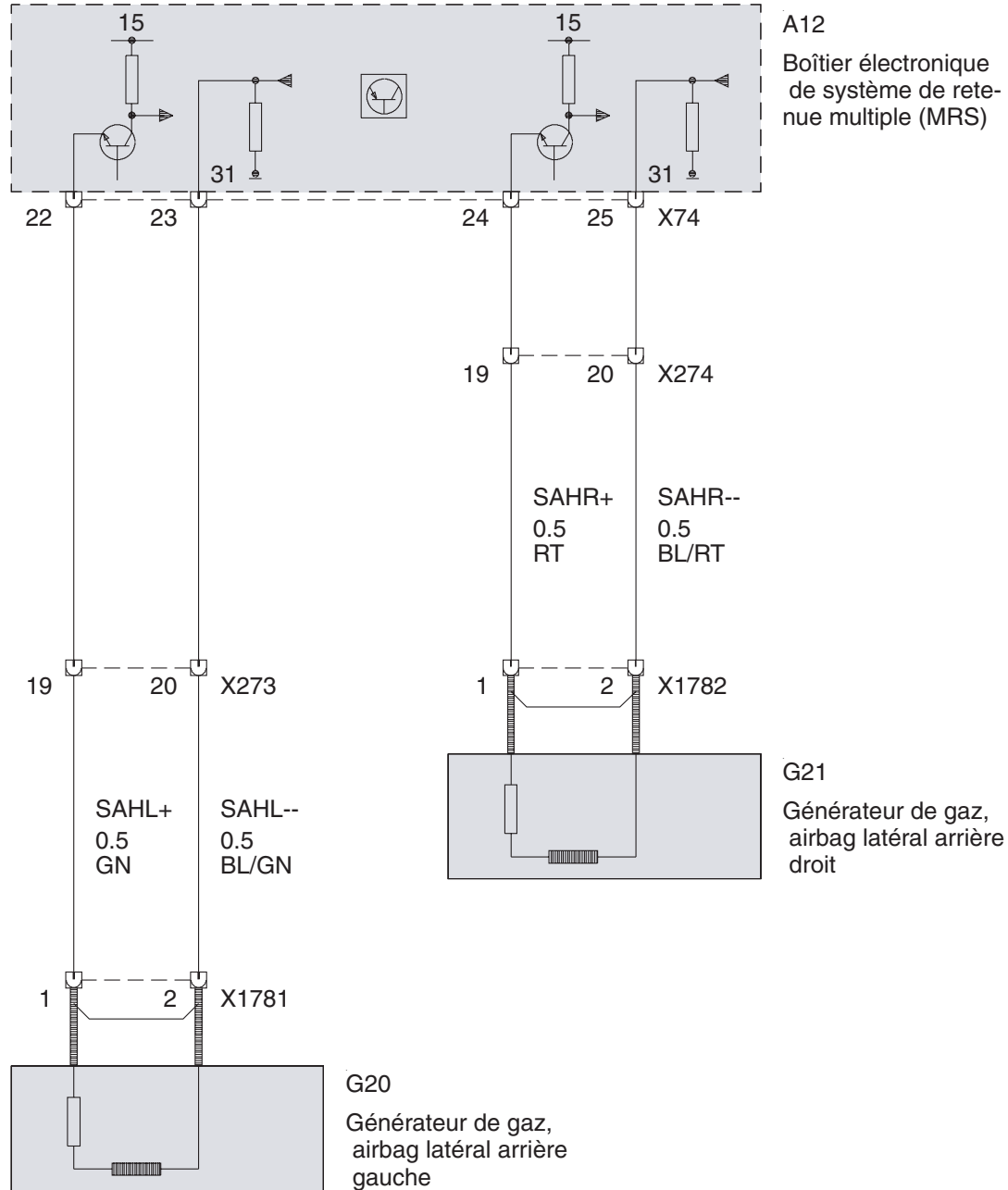

Airbag latéral arrière (Coupé ou Cabriolet ou Compact)

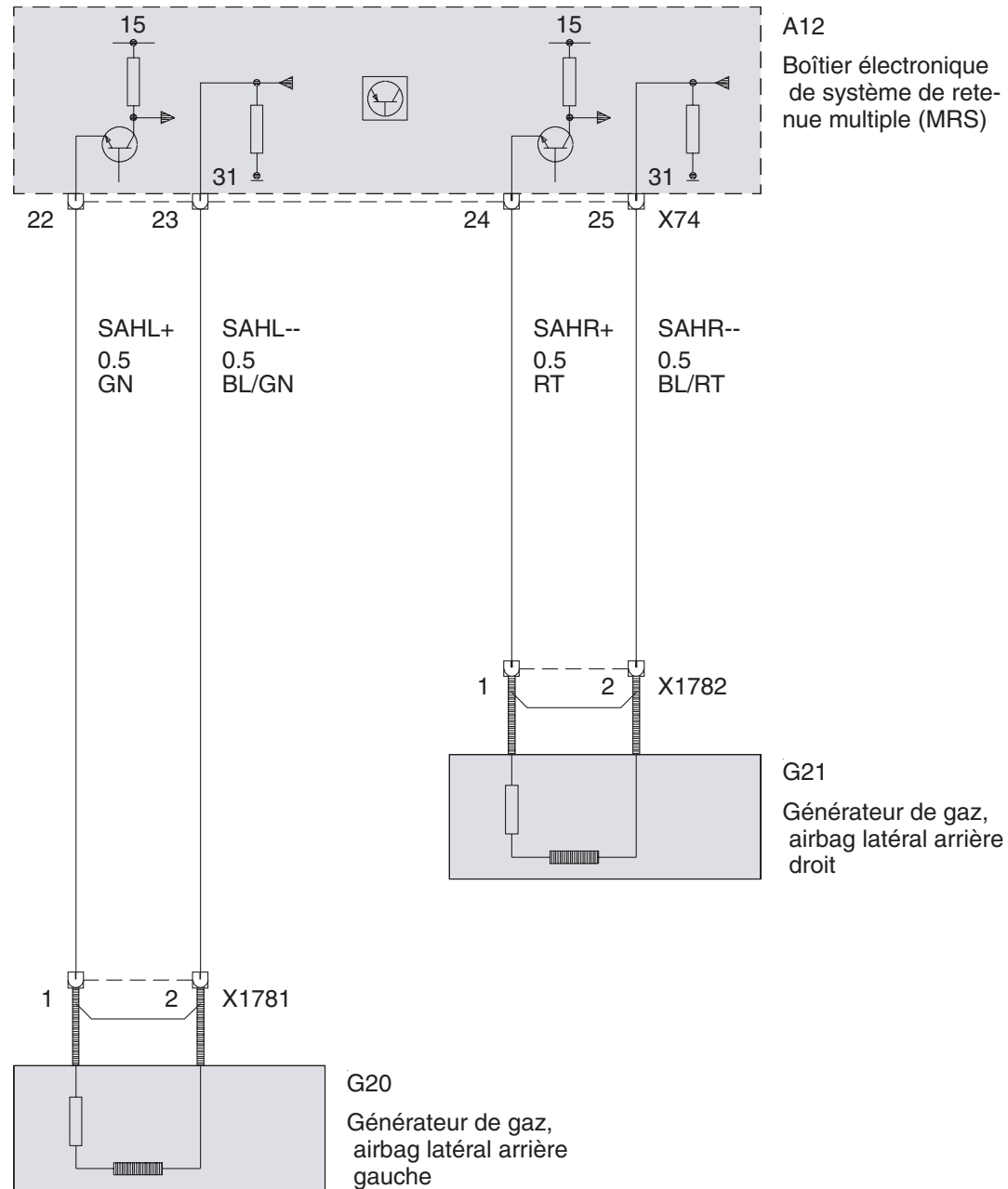

**Ceinture de sécurité**  
Rétracteur de ceinture

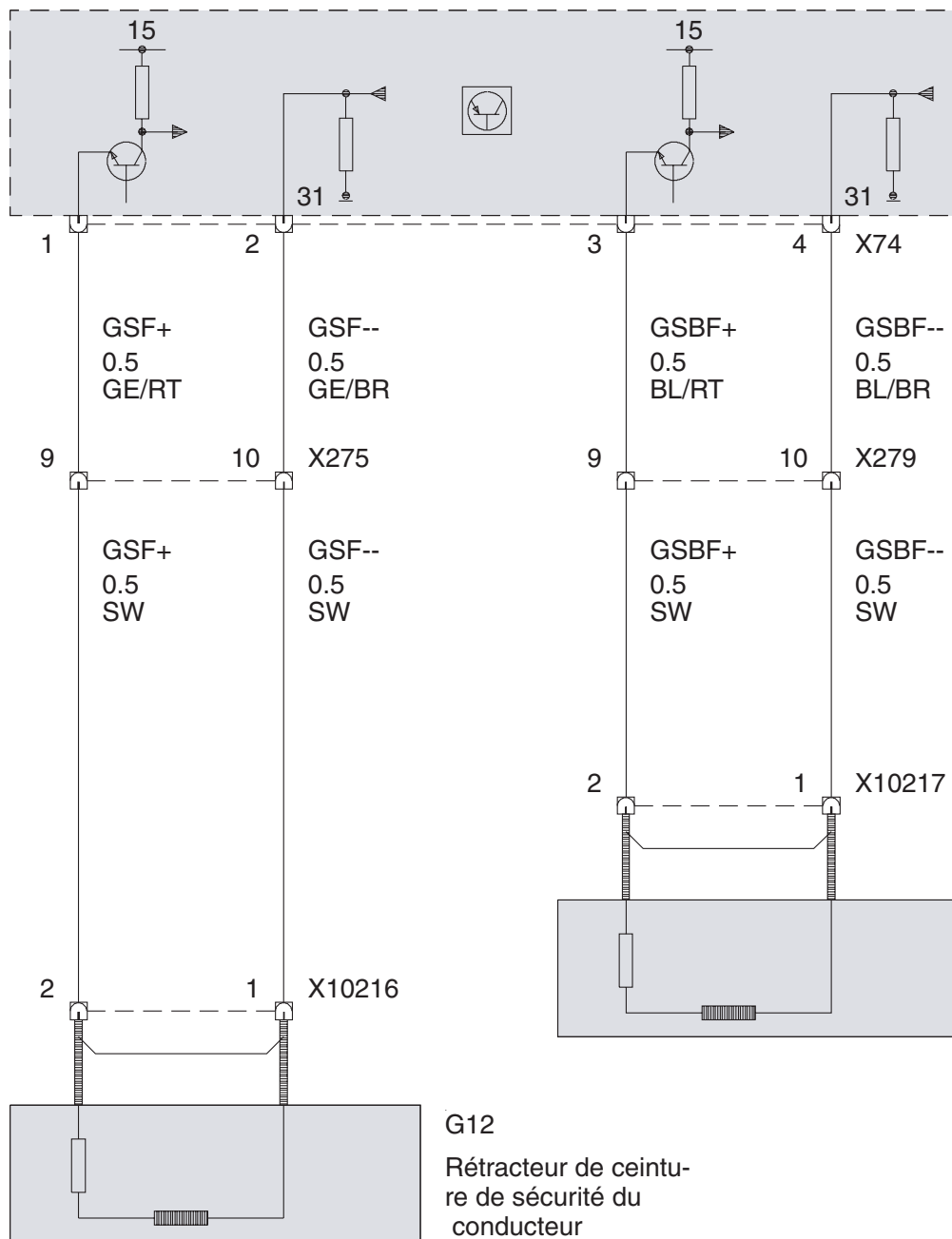

A12  
Boîtier électronique  
de système de rete-  
neue multiple (MRS)

G13  
Rétracteur de ceintu-  
re de sécurité du  
passager

G12  
Rétracteur de ceintu-  
re de sécurité du  
conducteur

Contacteur de ceinture de sécurité côté conducteur

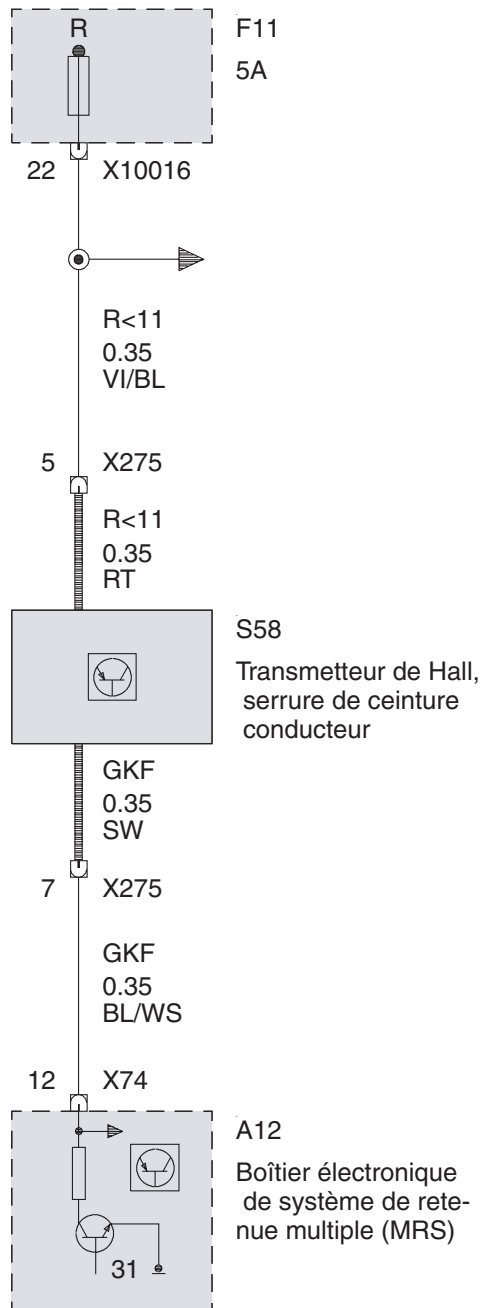



Détection d'occupation de siège

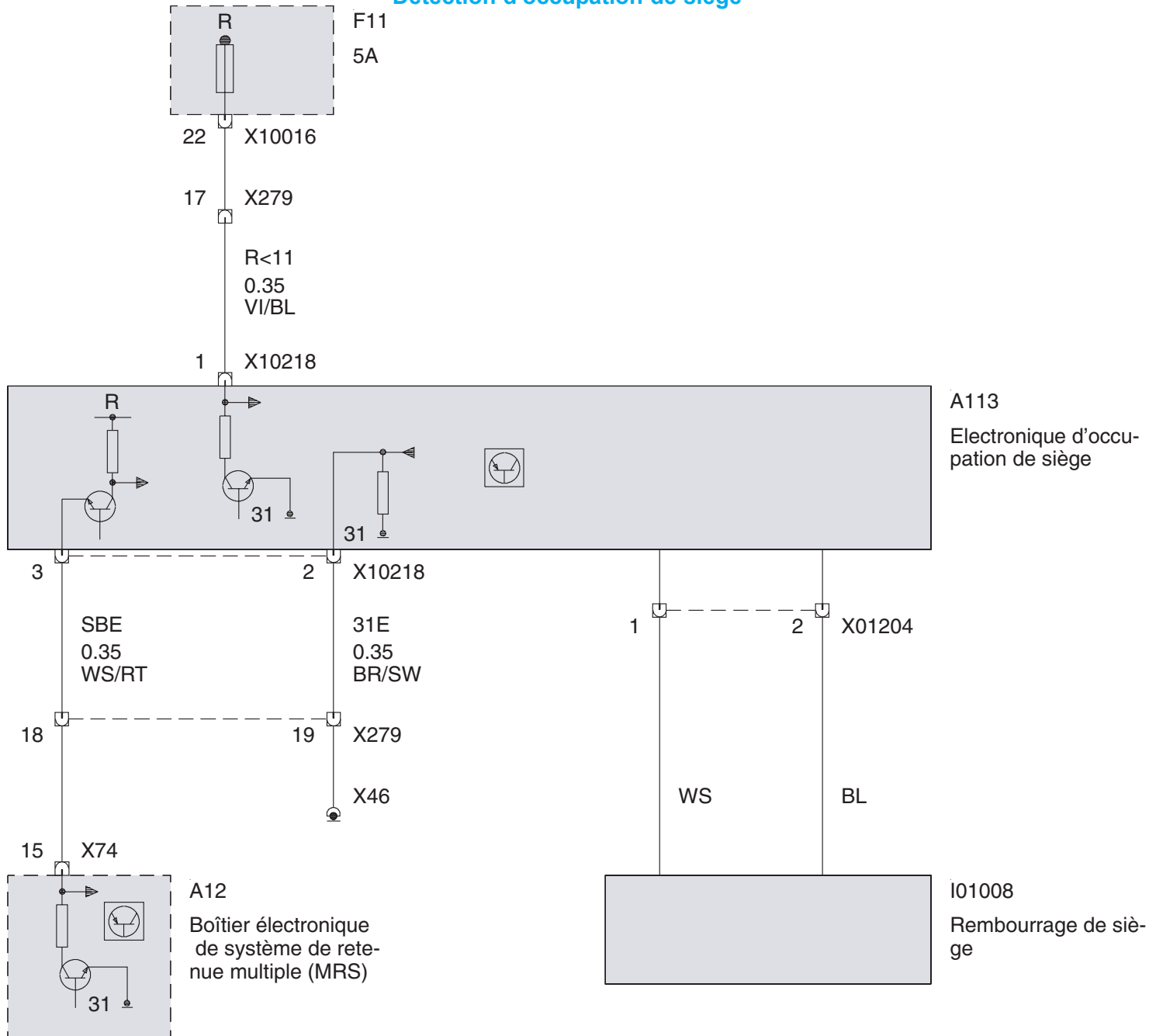

Coupe-câble de batterie

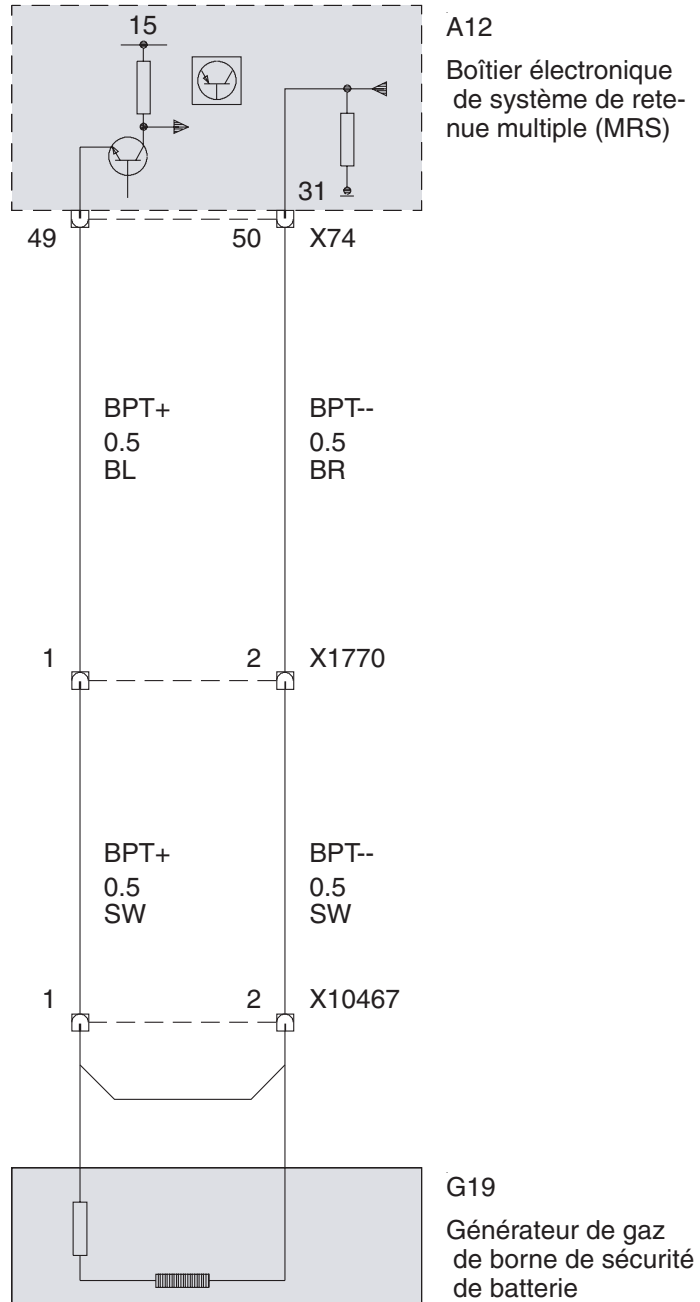

A12  
Boîtier électronique  
de système de rete-  
nue multiple (MRS)

G19  
Générateur de gaz  
de borne de sécurité  
de batterie

Verrouillage dossier de siège

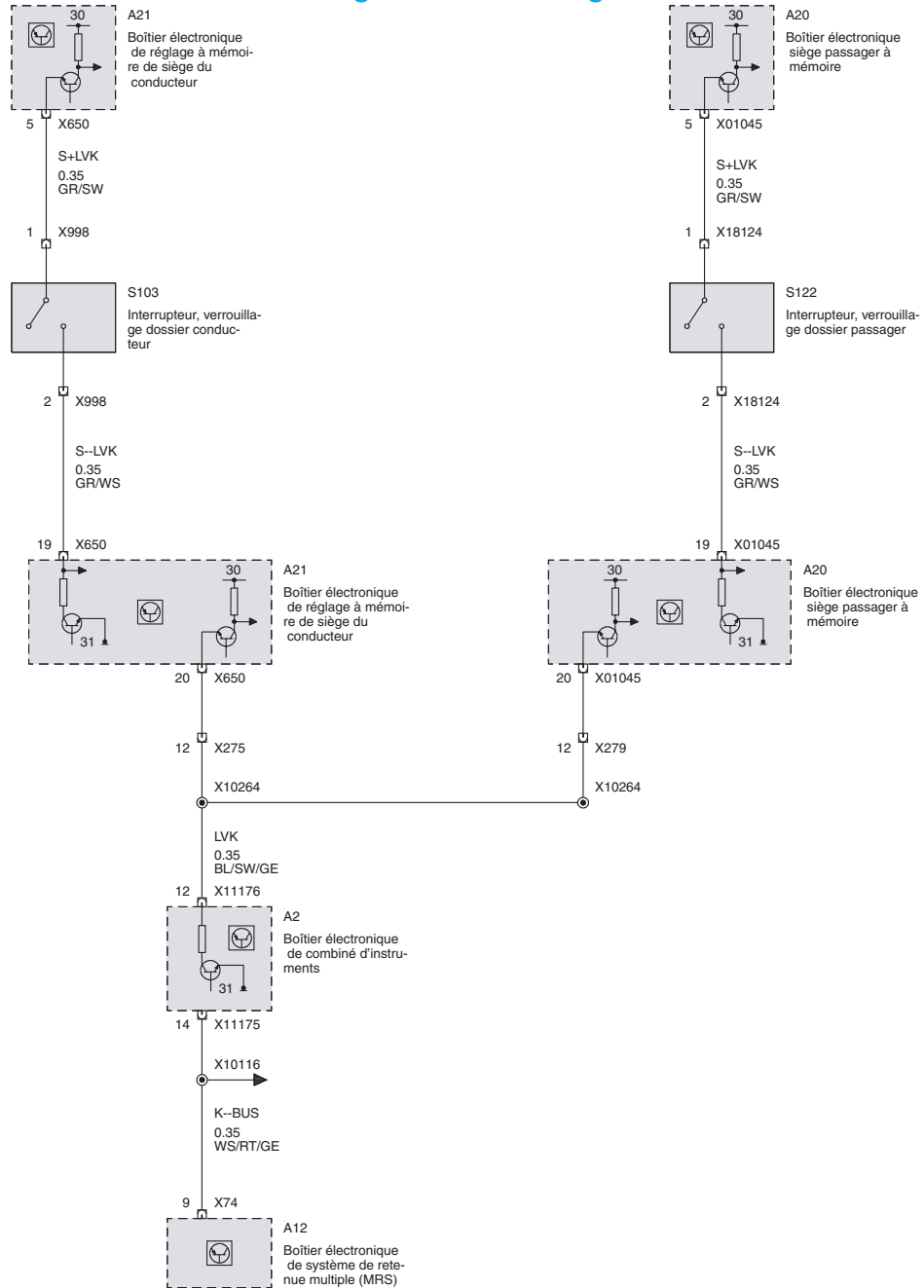

### Lève-glaces et toit ouvrant Lève-glace avant (Berline ou Touring)

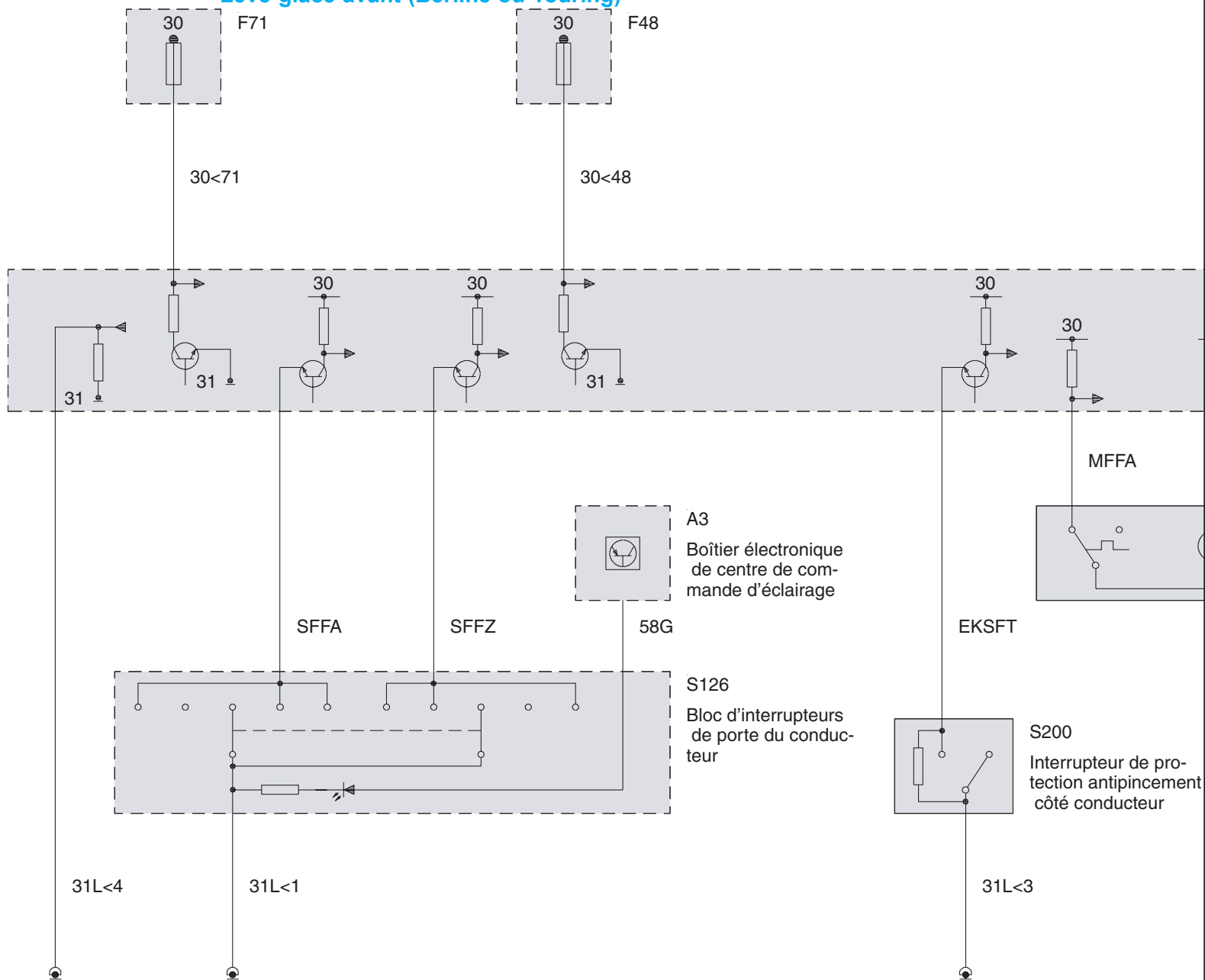

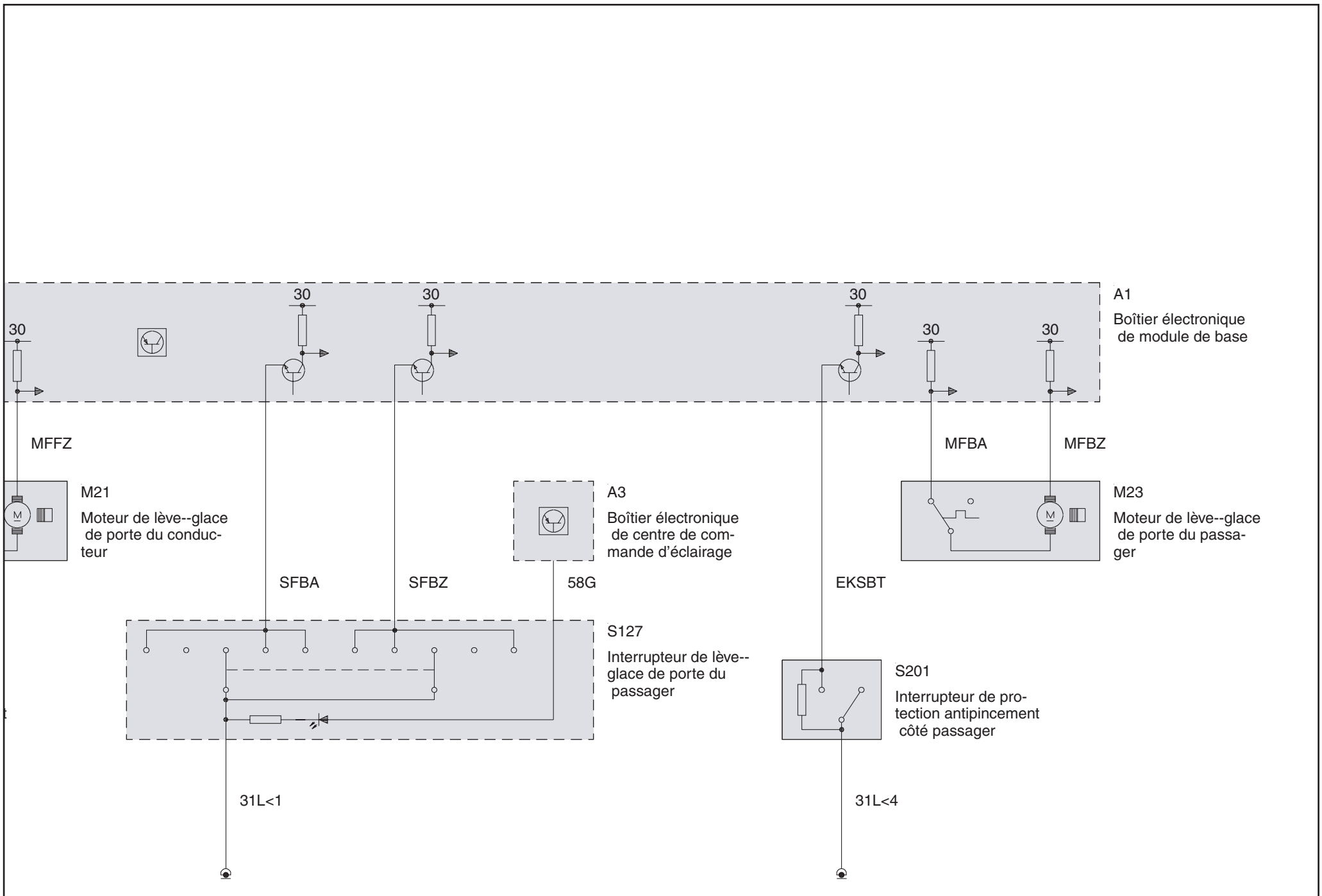

Lève-glace avant (Compact)

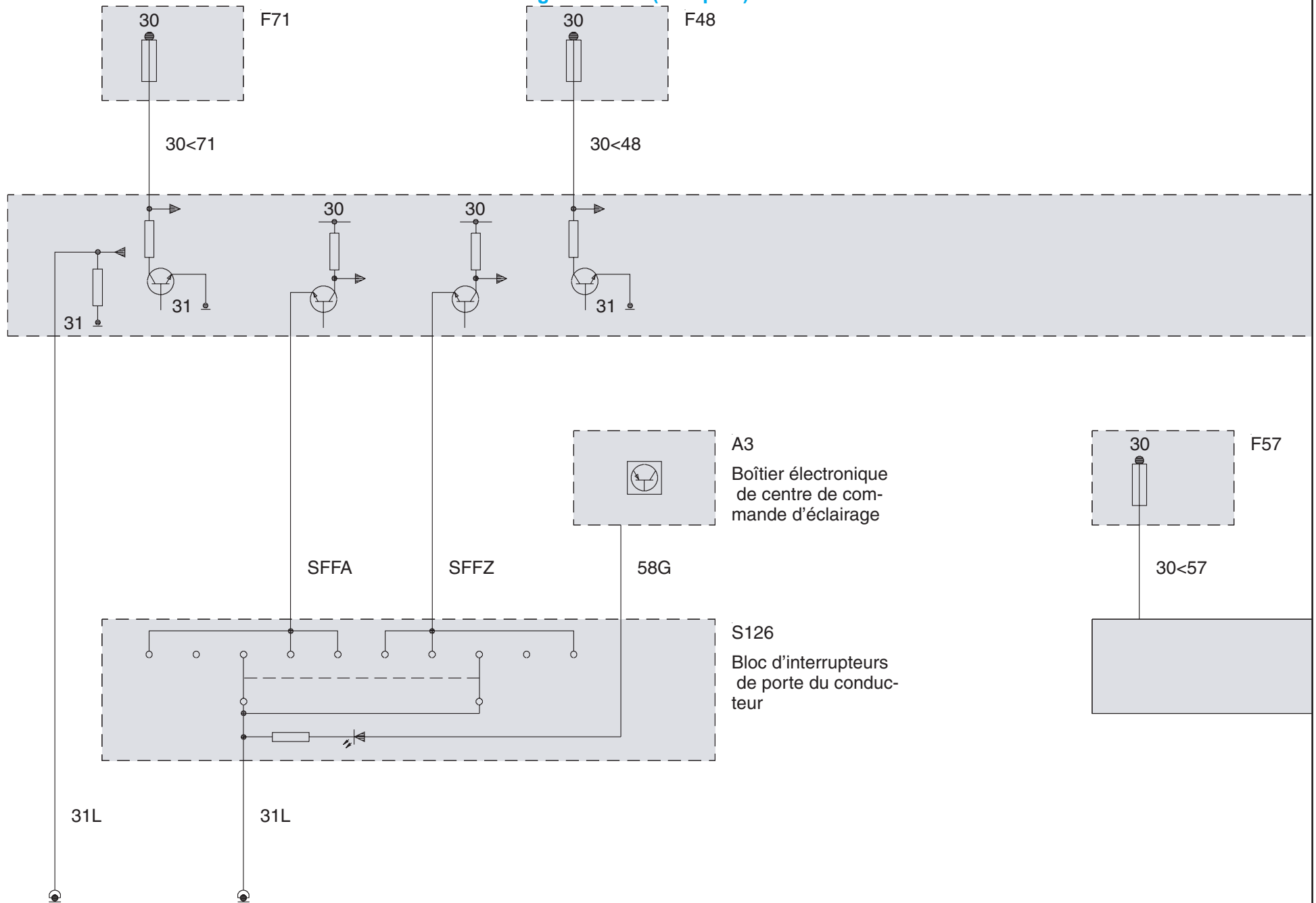

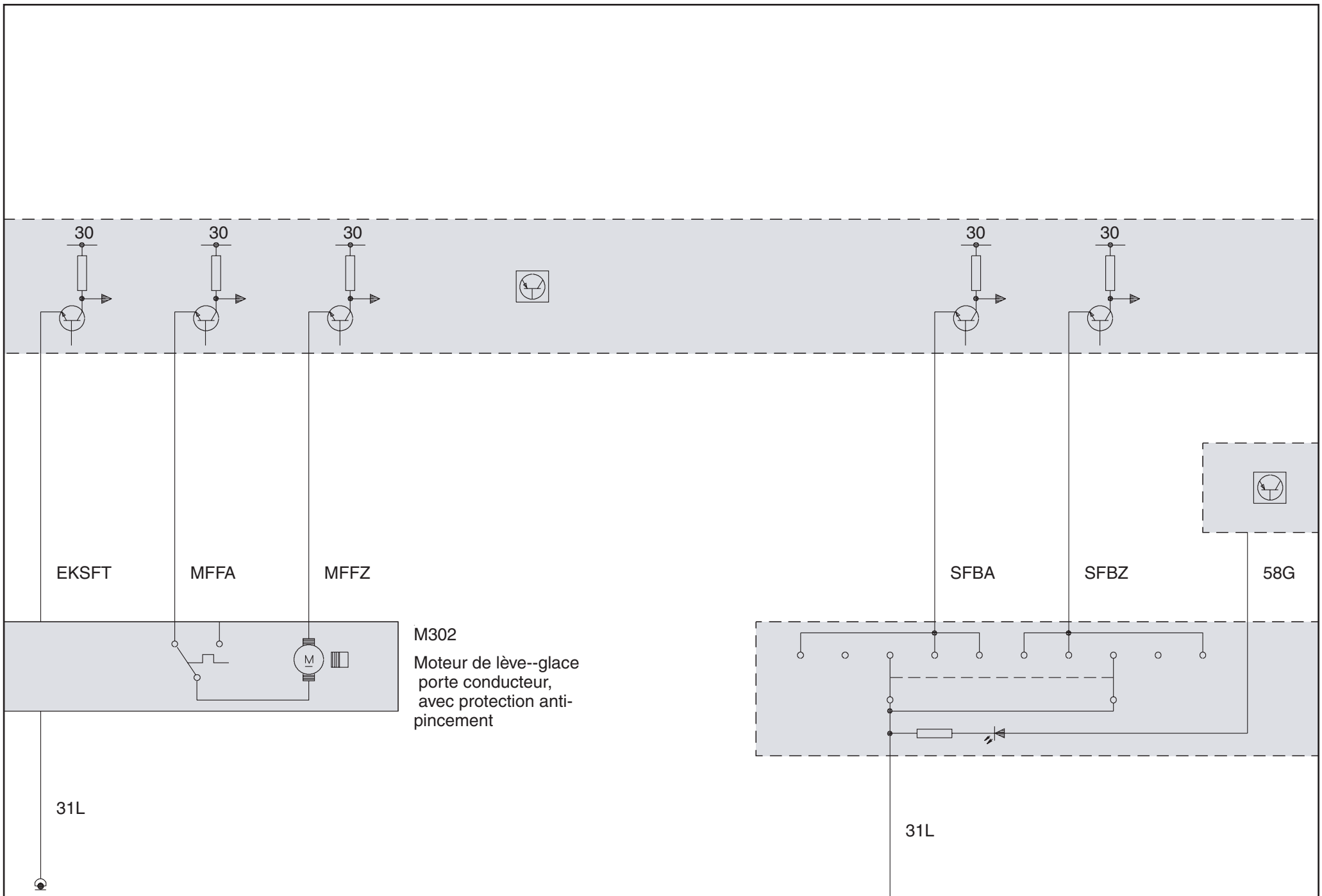

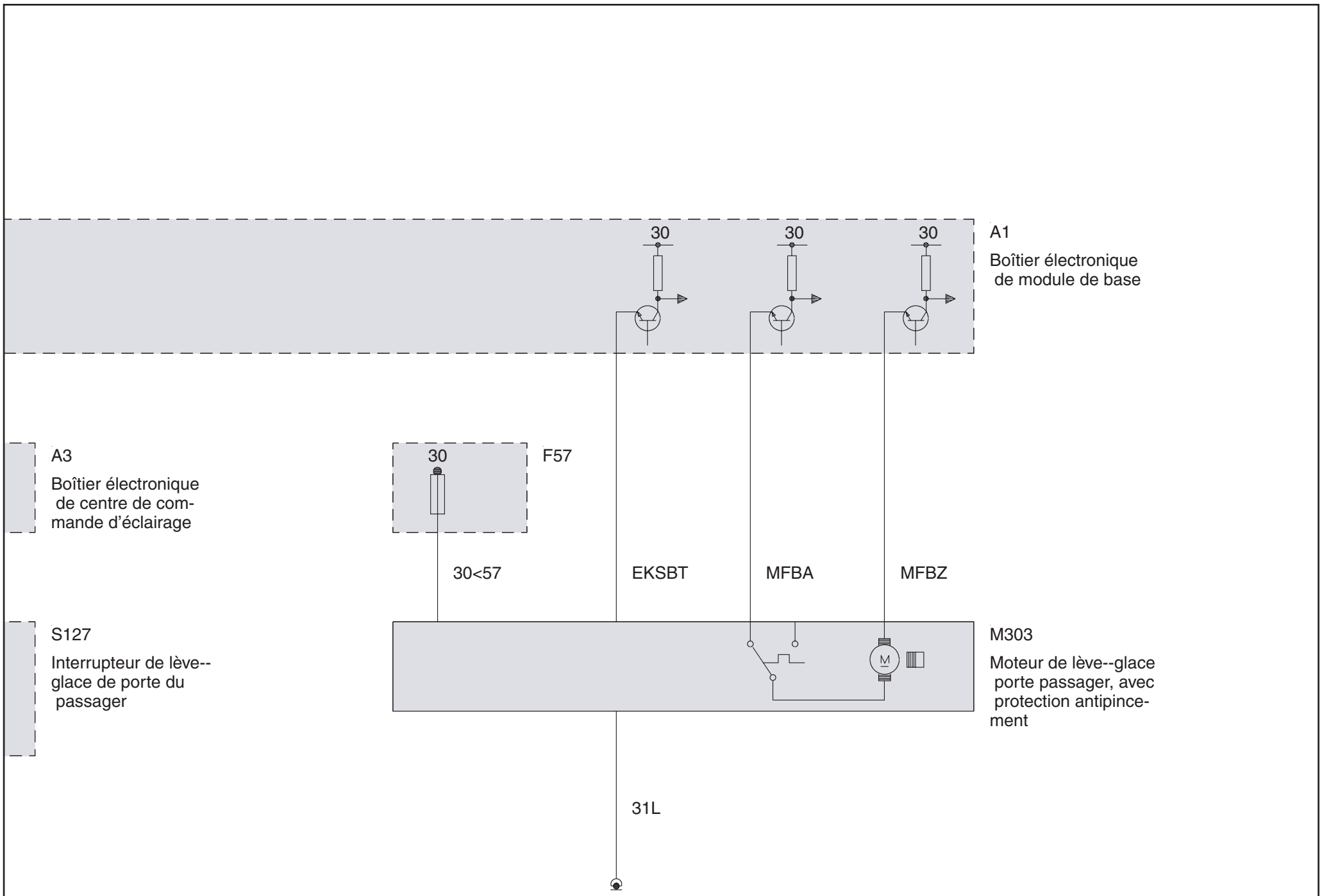



Lève-glace arrière

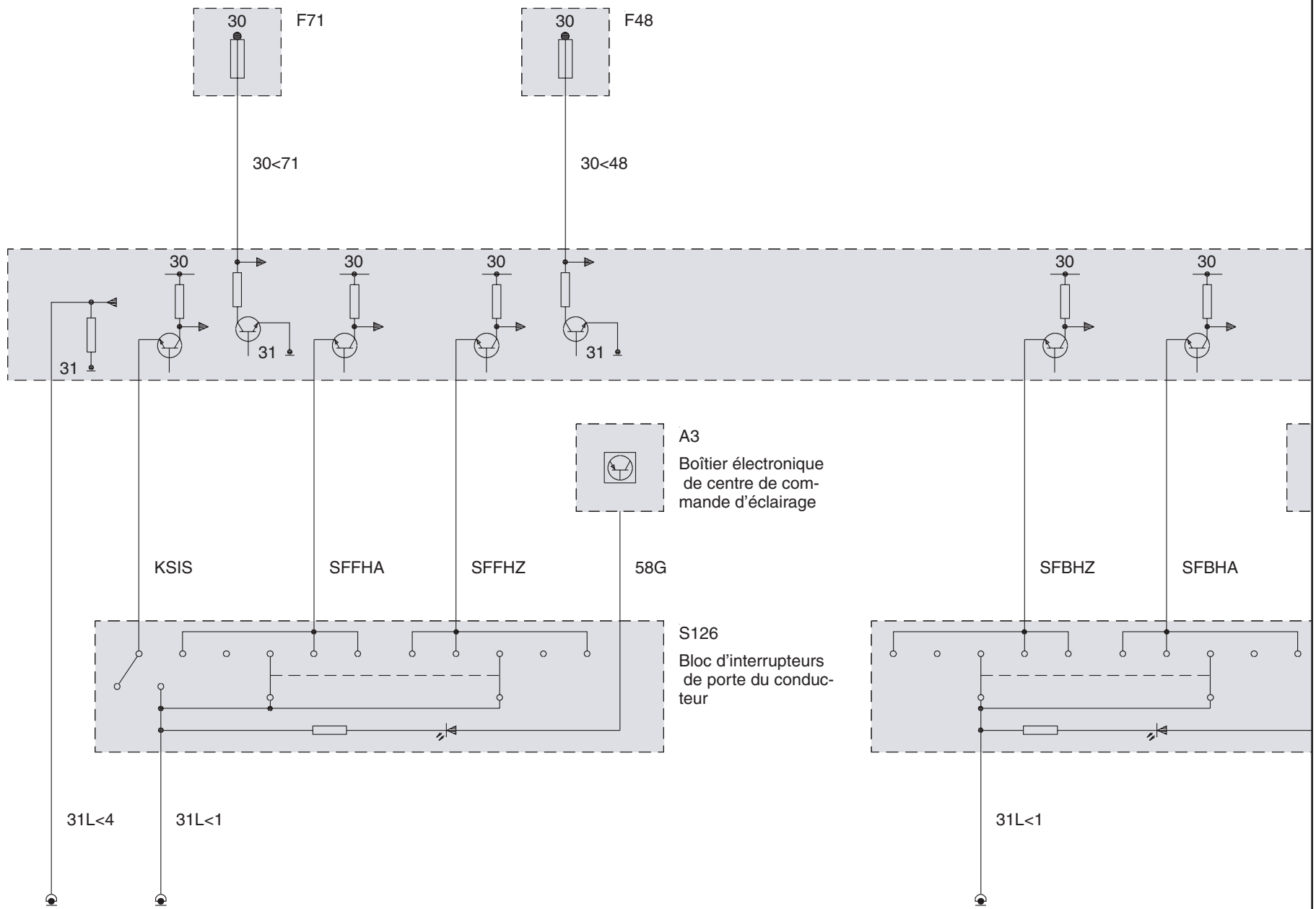

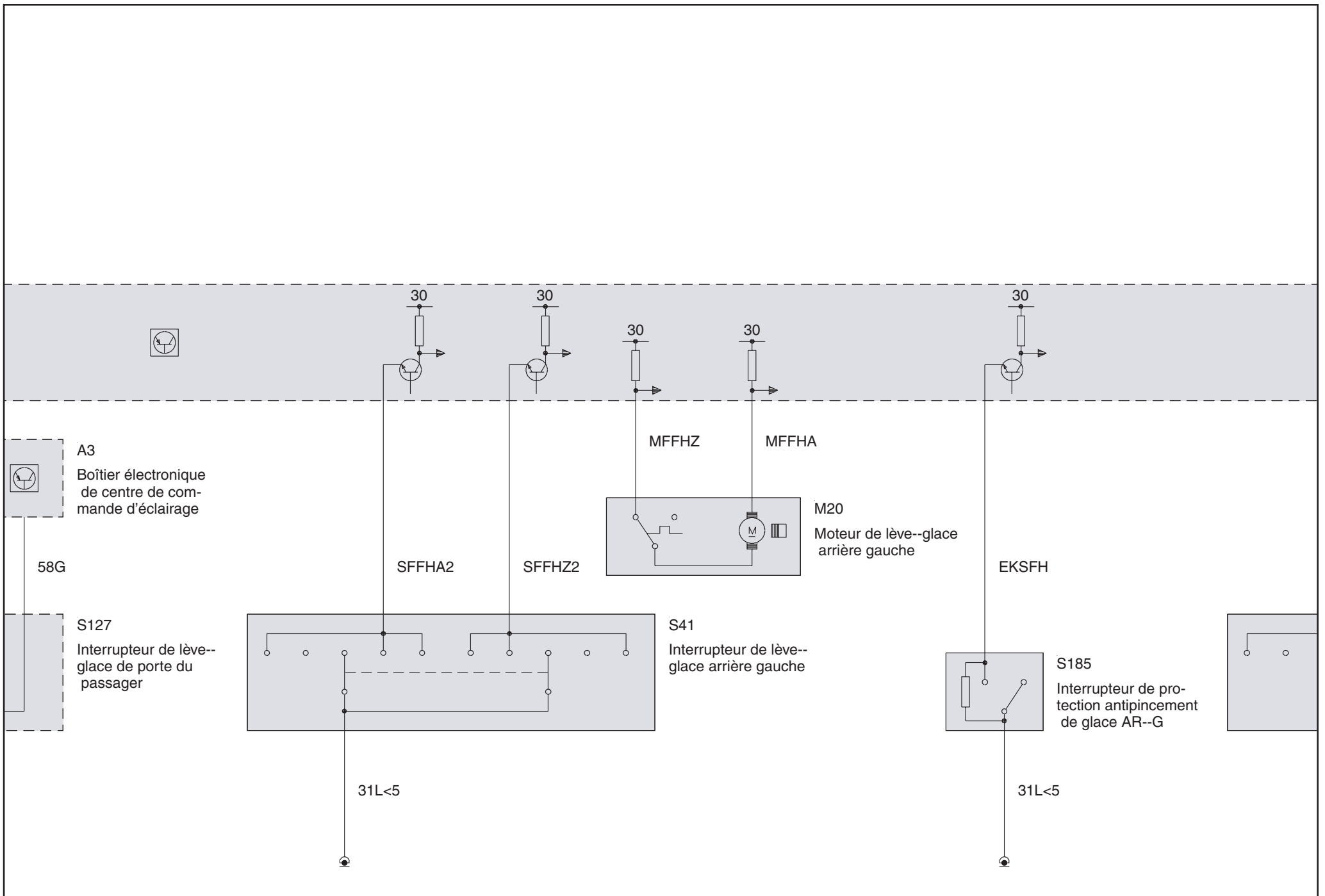

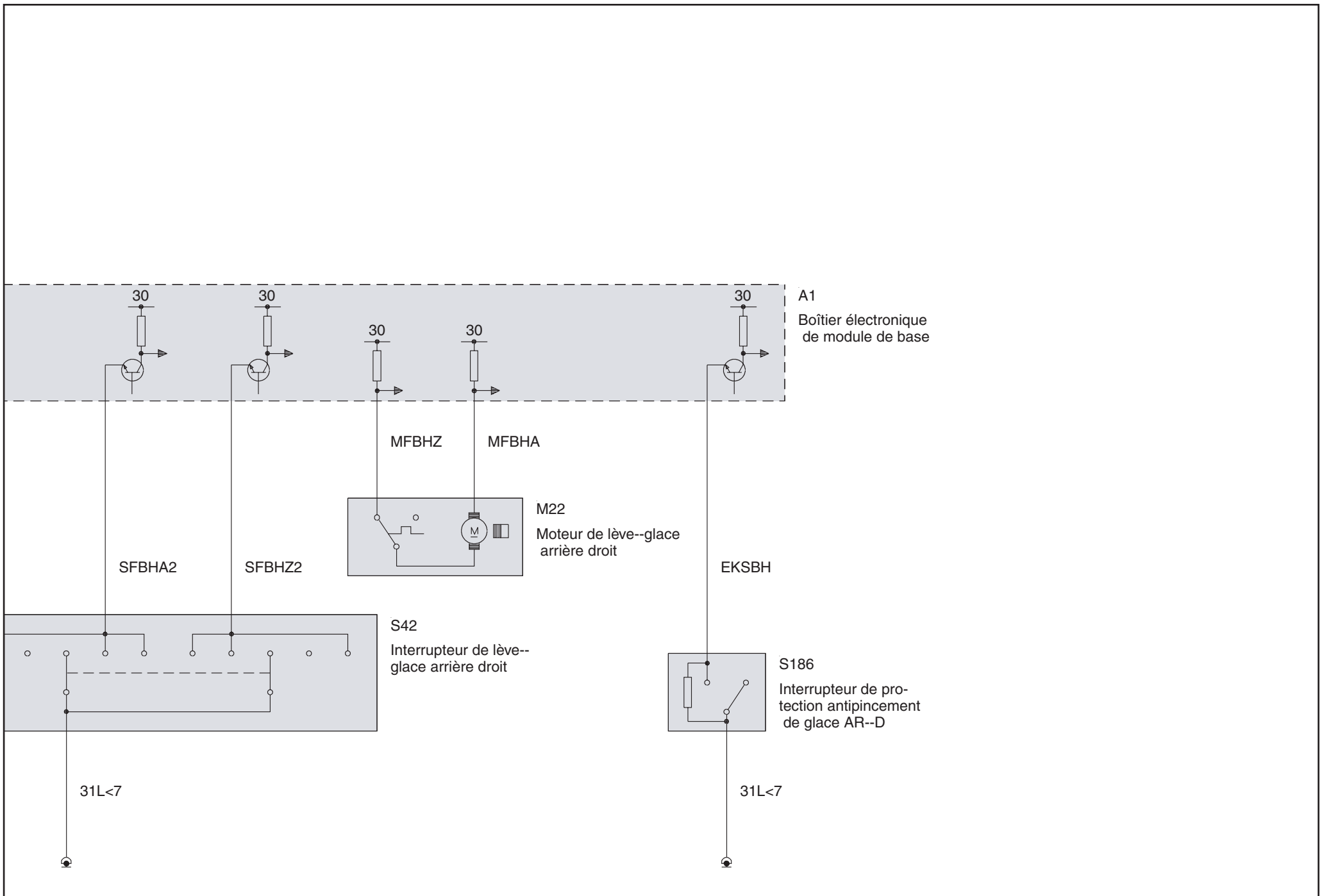

### Commutateur de lève-vitre Commutateur de lève-vitre côté conducteur (Berline ou Touring)

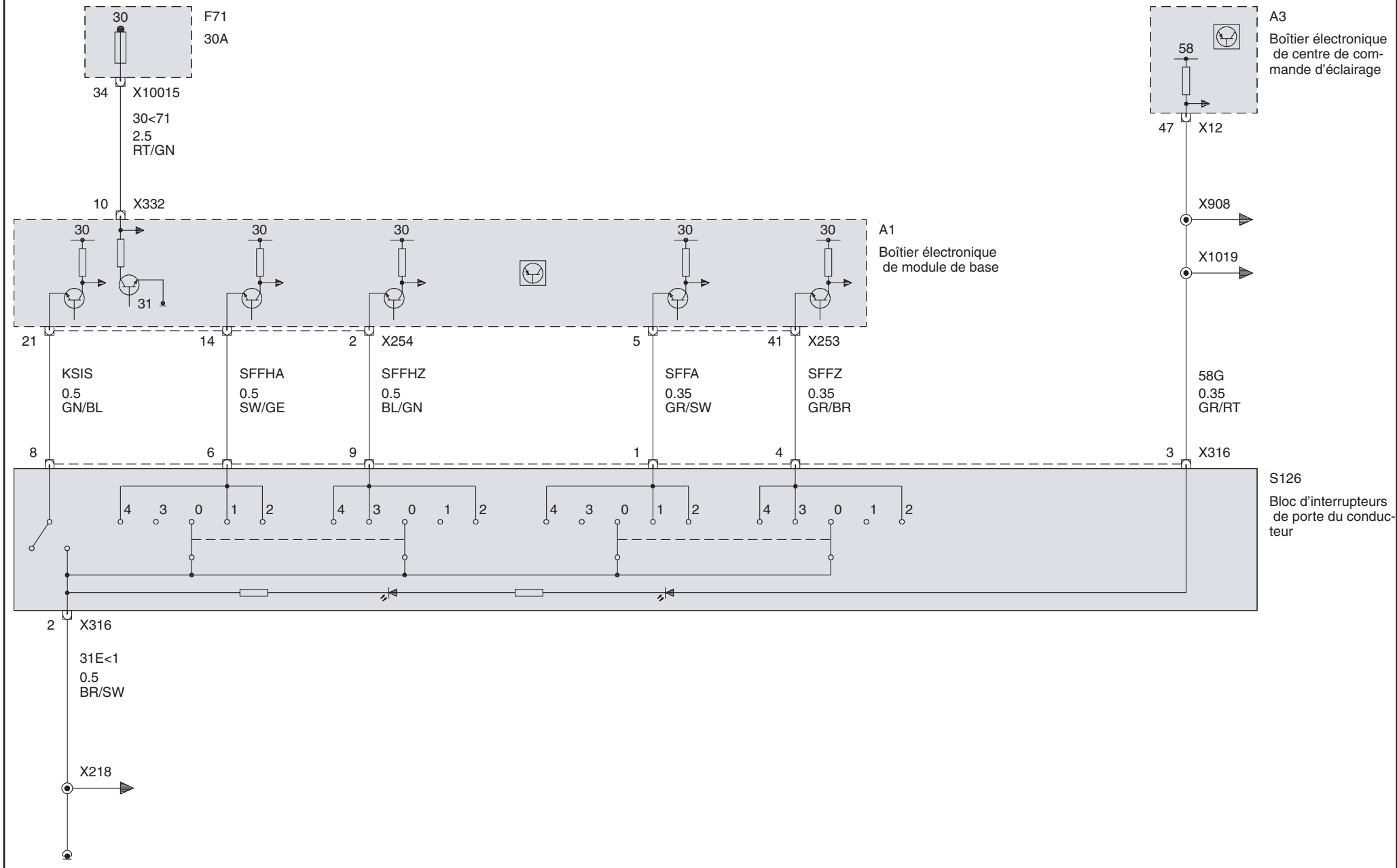

Commutateur de lève-vitre côté conducteur (Coupé)

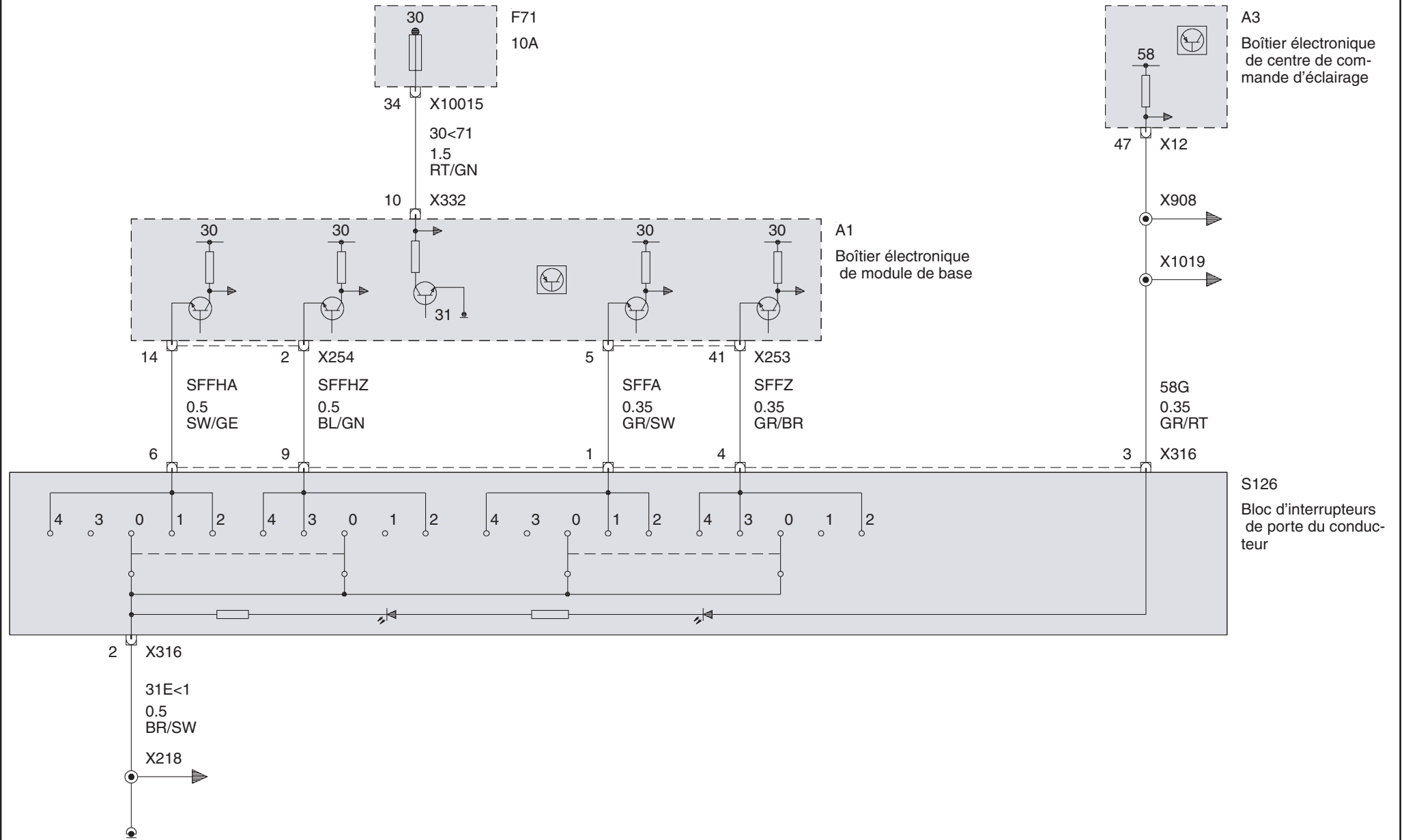

Commutateur de lève-vitre côté conducteur (Compact)

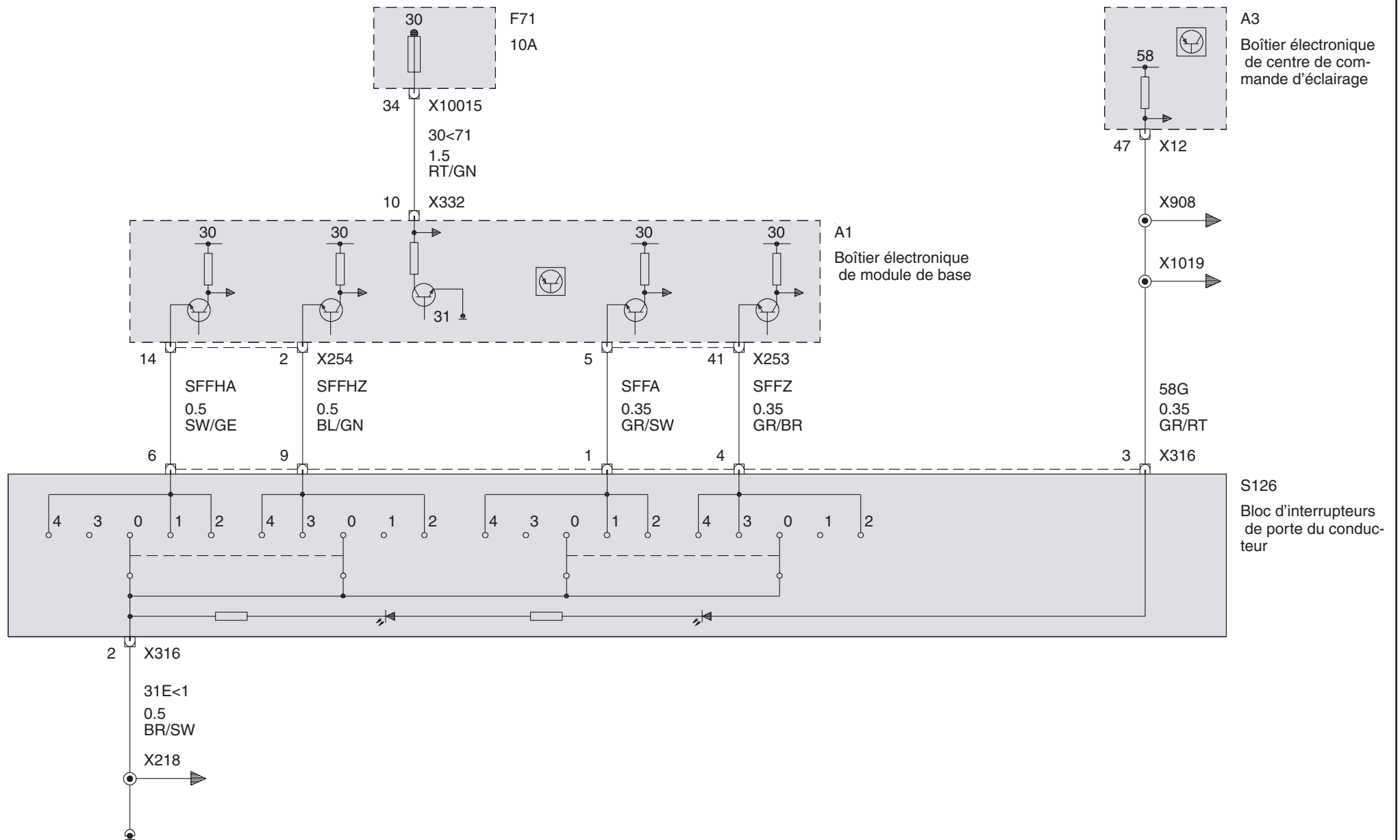

Commutateur de lève-vitre côté passager

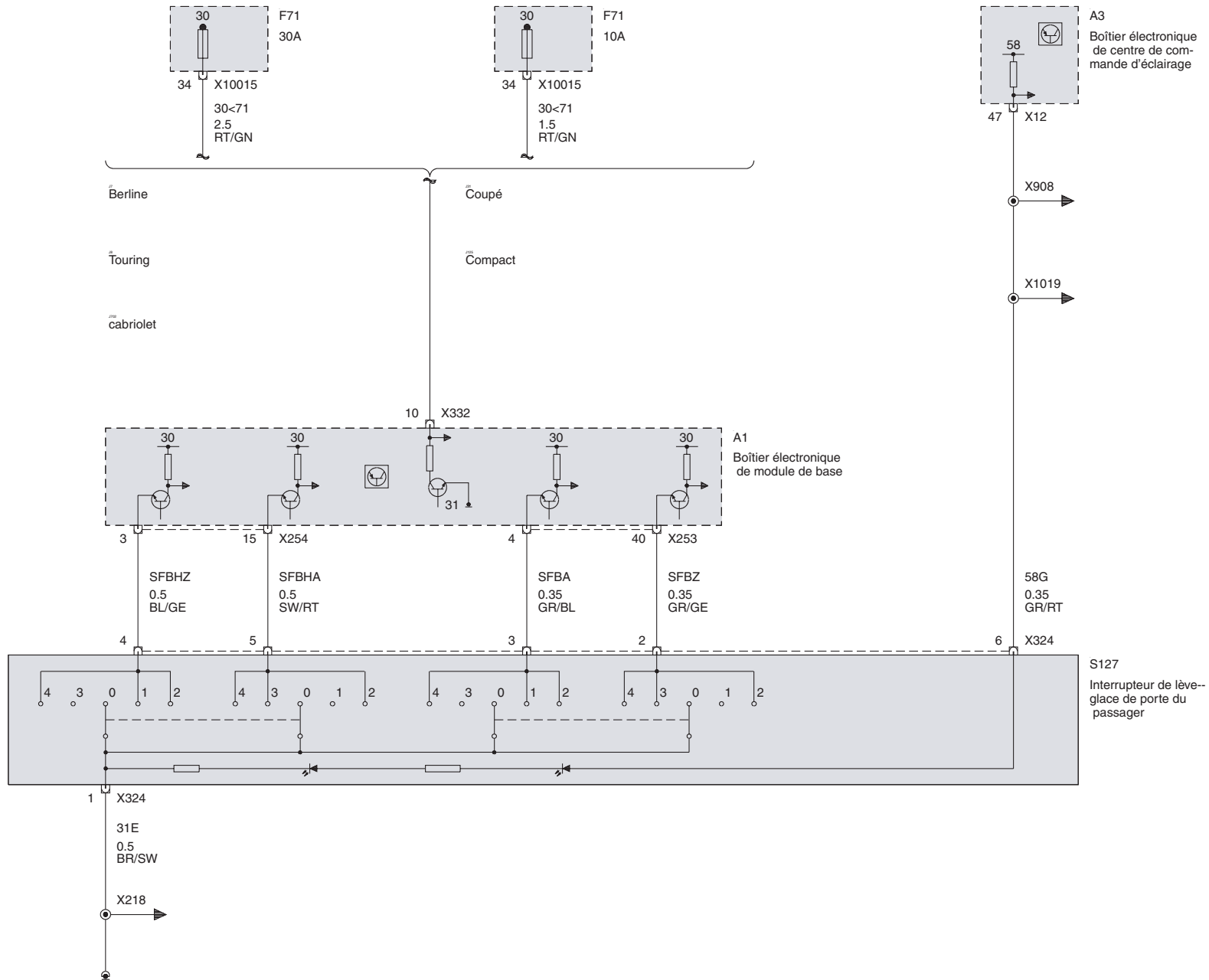

Actionneurs des lève-vitres avant

Moteur de lève-glace avant côté conducteur (Berline ou Touring)

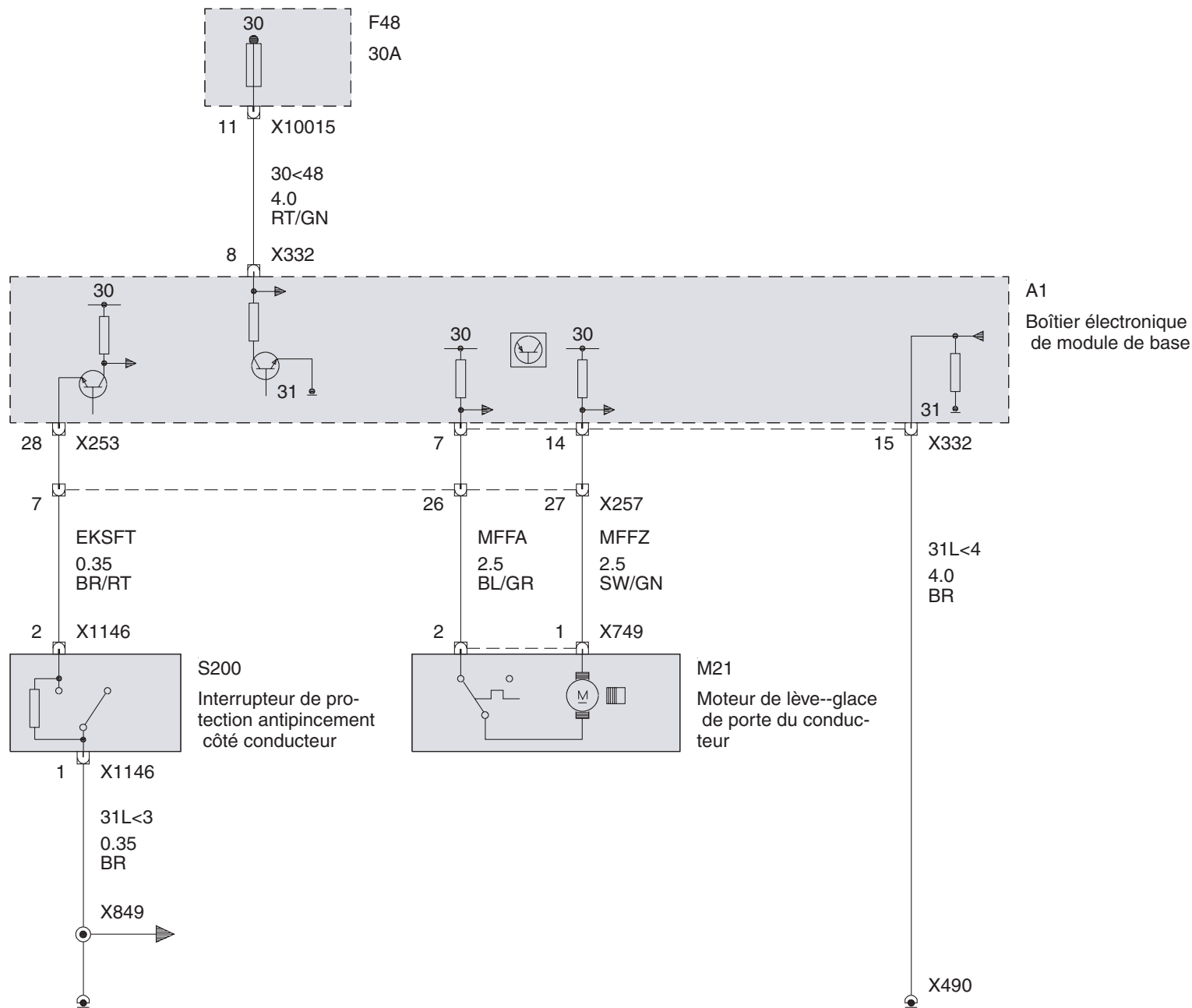



Moteur de lève-glace avant côté conducteur (Compact jusque 2003\_03)

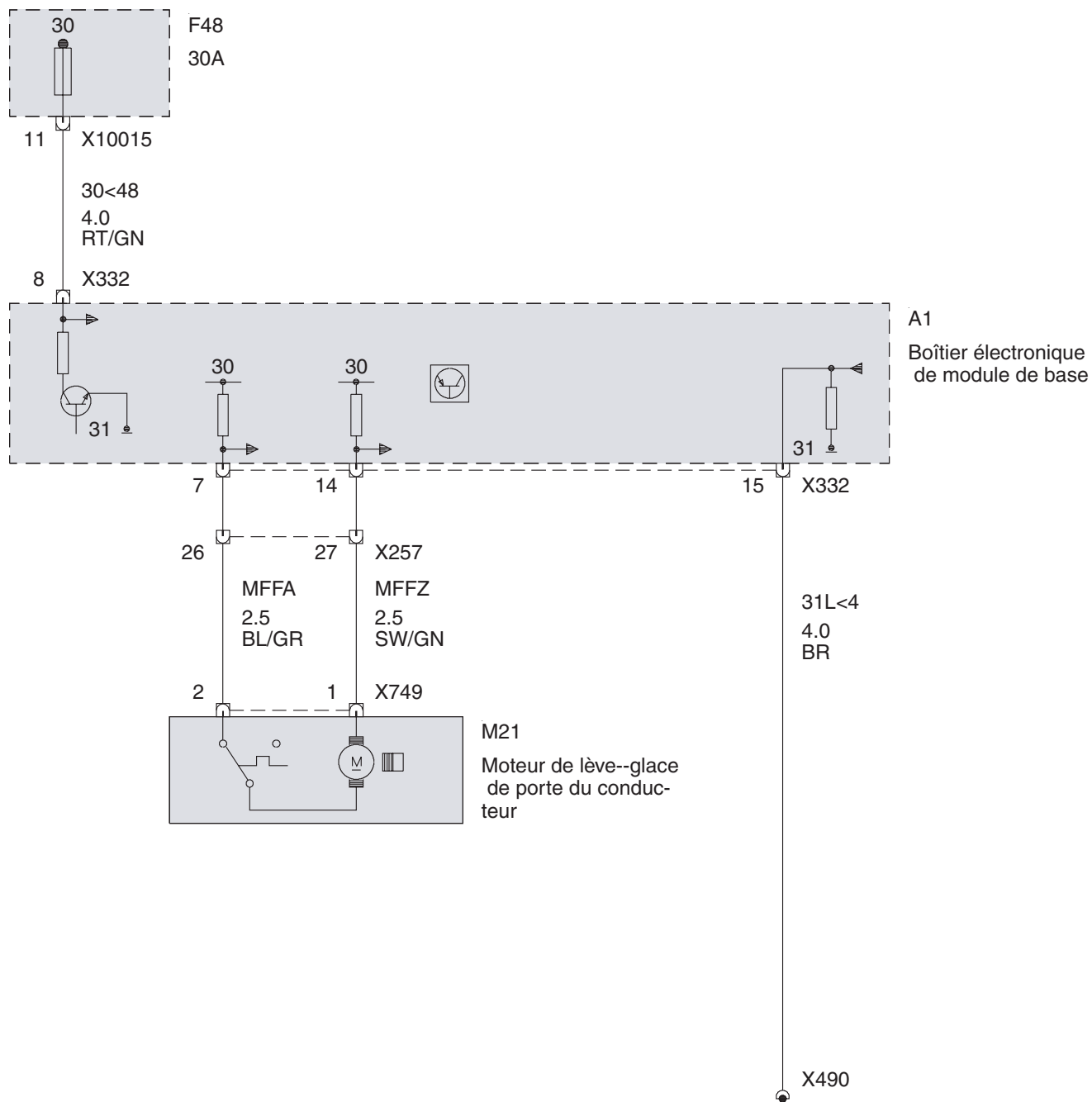

Moteur de lève-glace avant côté conducteur (Compact à partir de 2003\_03)

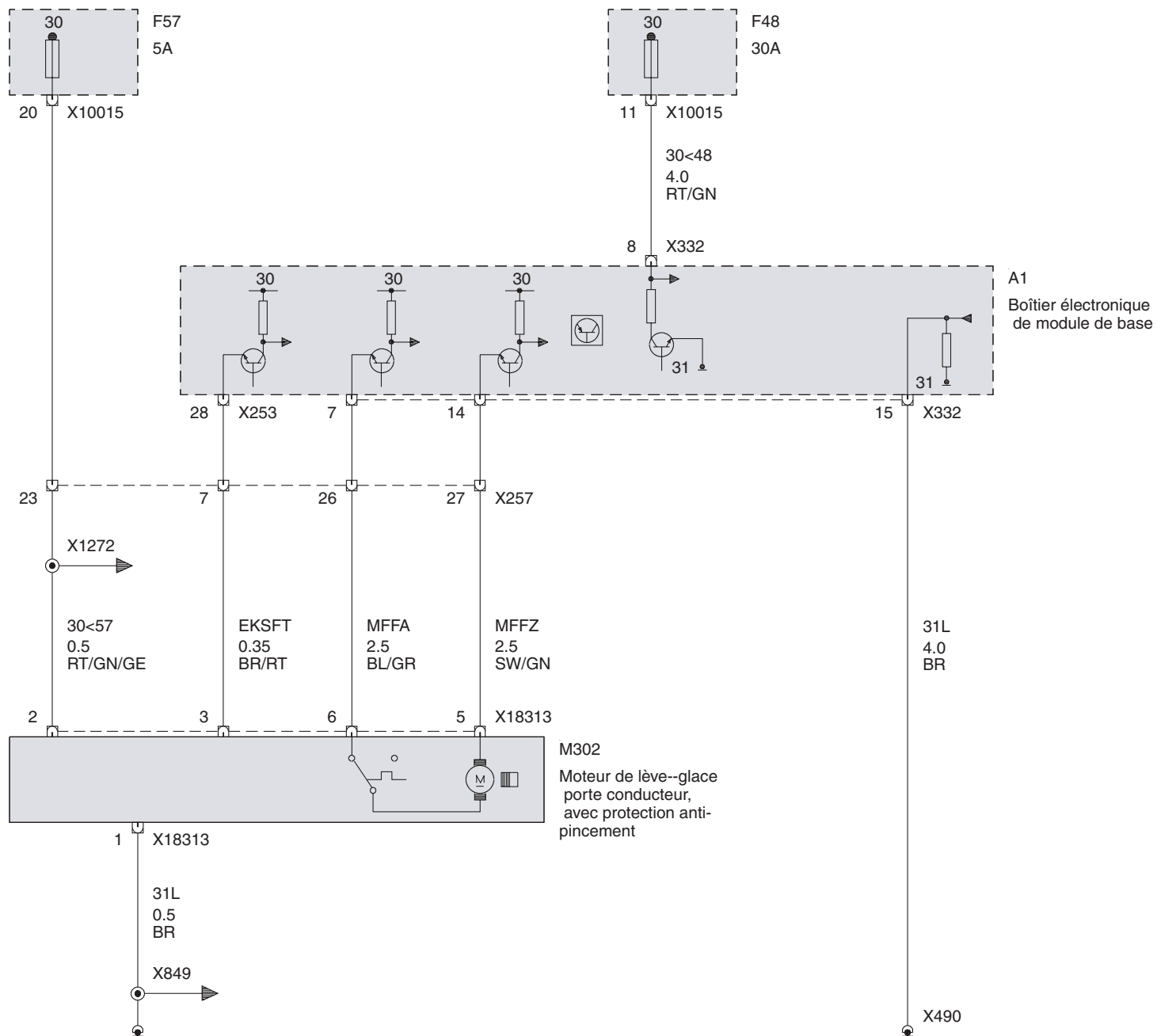

Moteur de lève-glace avant côté conducteur (Coupé)

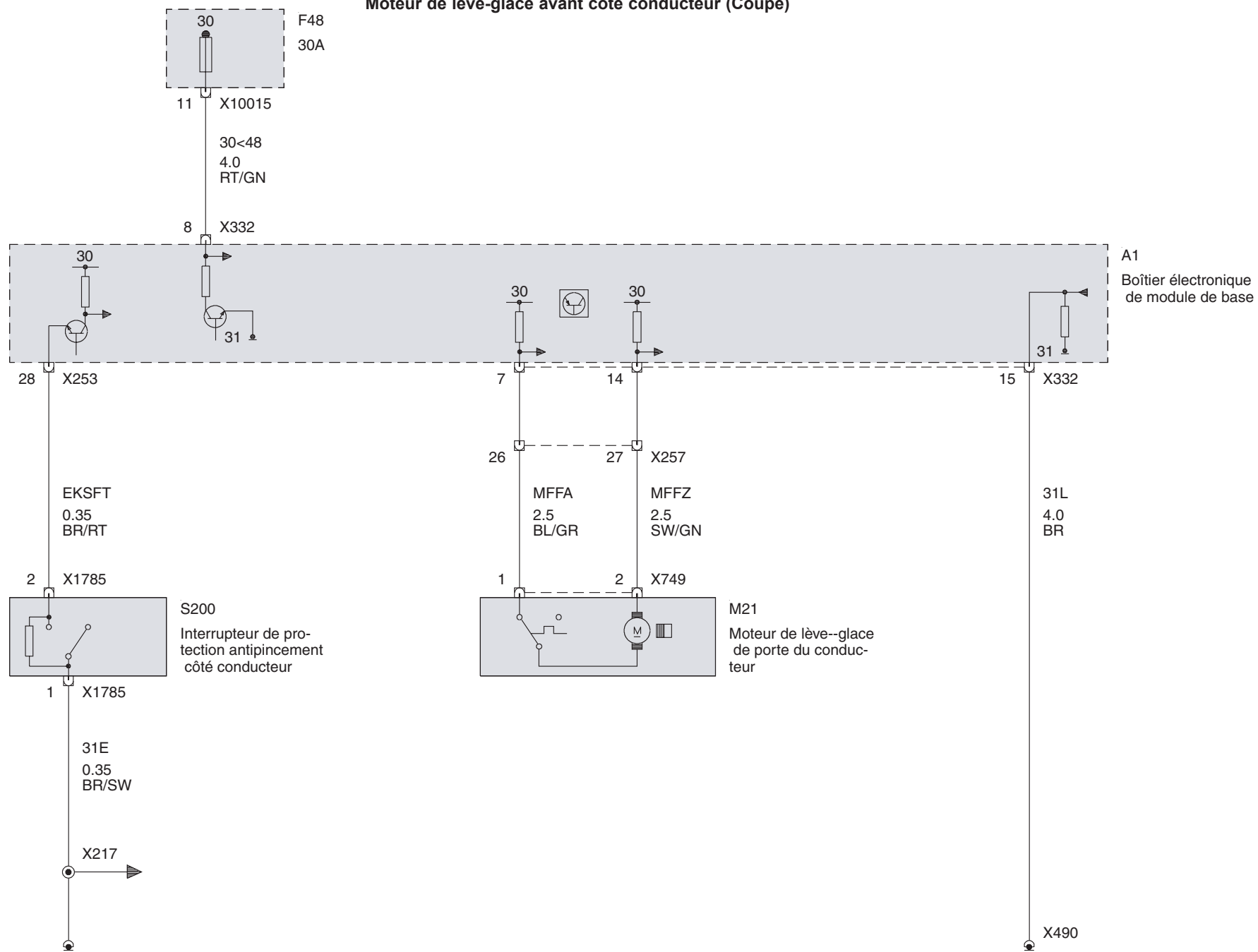

Moteur de lève-glace avant côté passager (Berline ou Touring)

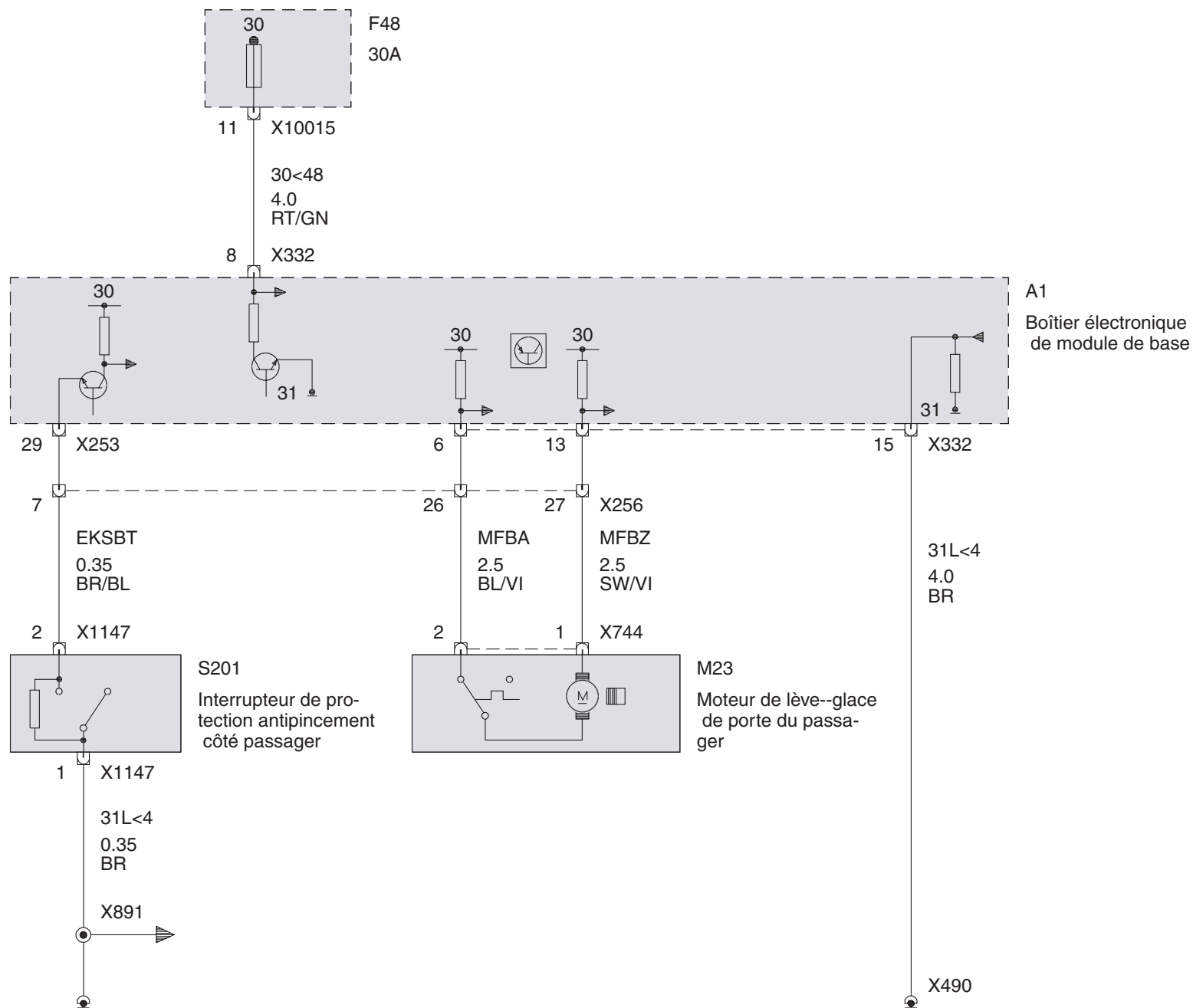

Moteur de lève-glace avant côté passager (Compact jusque 2003\_03)

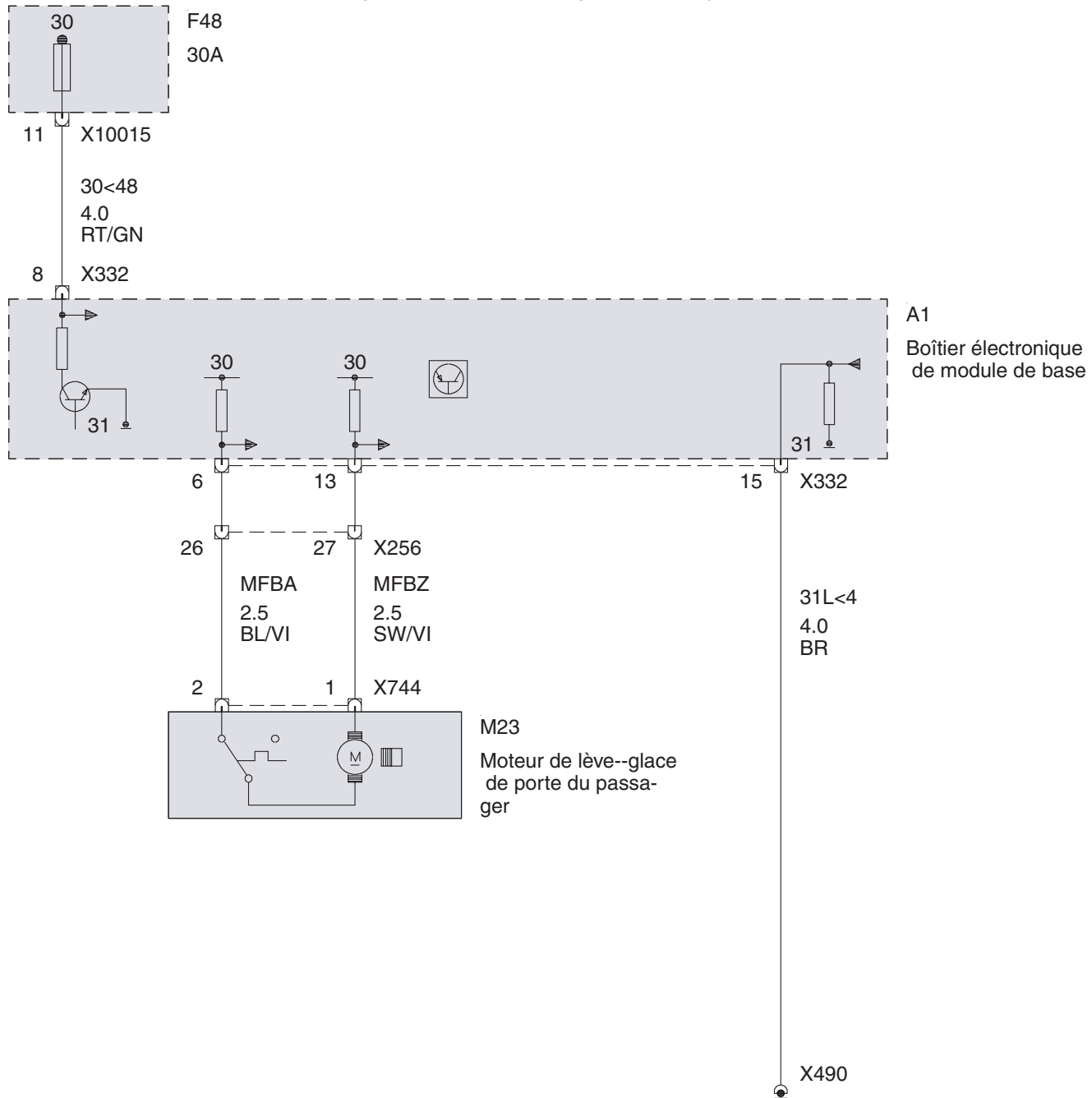

Moteur de lève-glace avant côté passager (Compact à partir de 2003\_03)

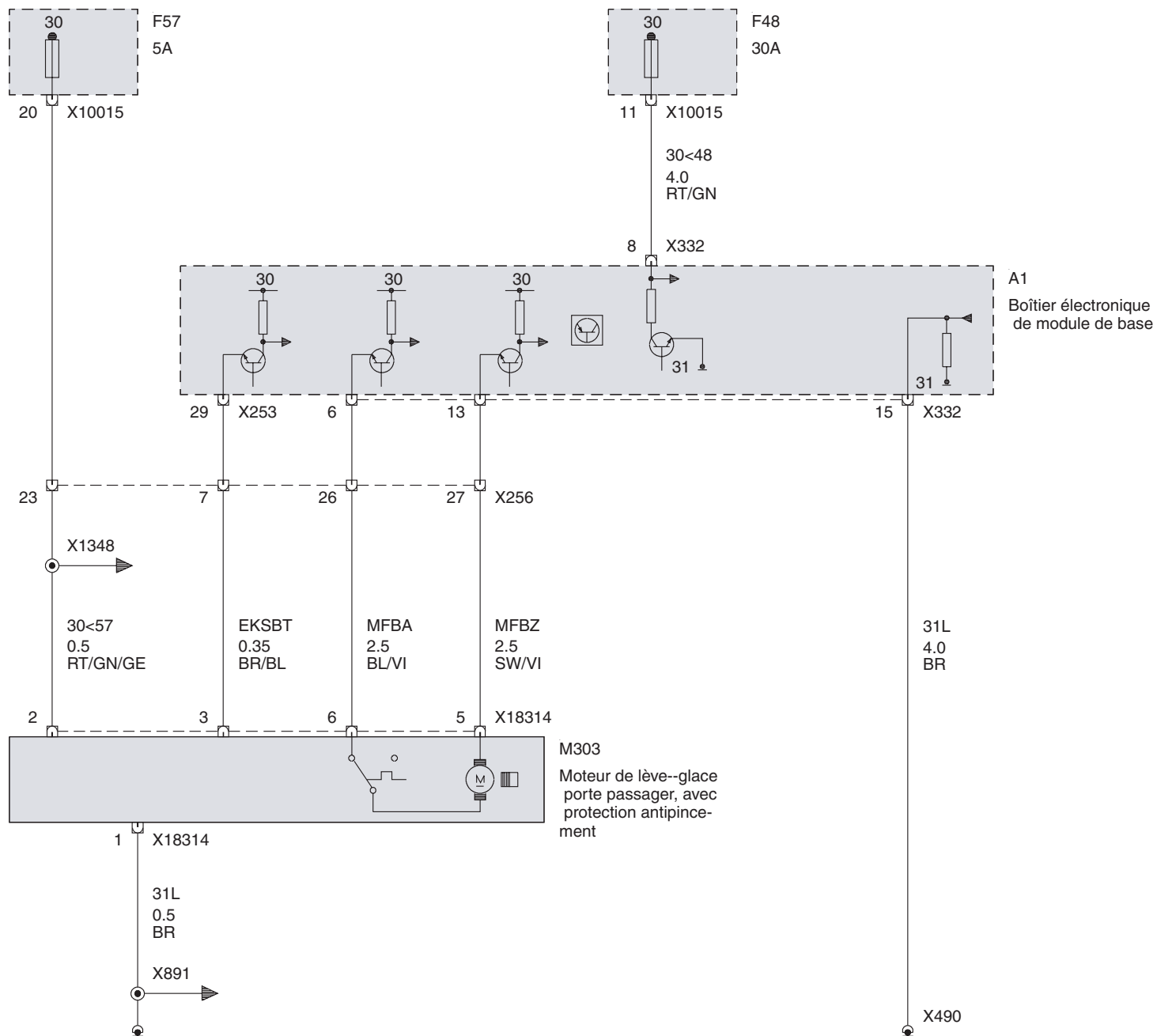



### Actionneurs des lève-vitres arrière (Berline ou Touring)

#### Moteur de lève-glace arrière côté conducteur

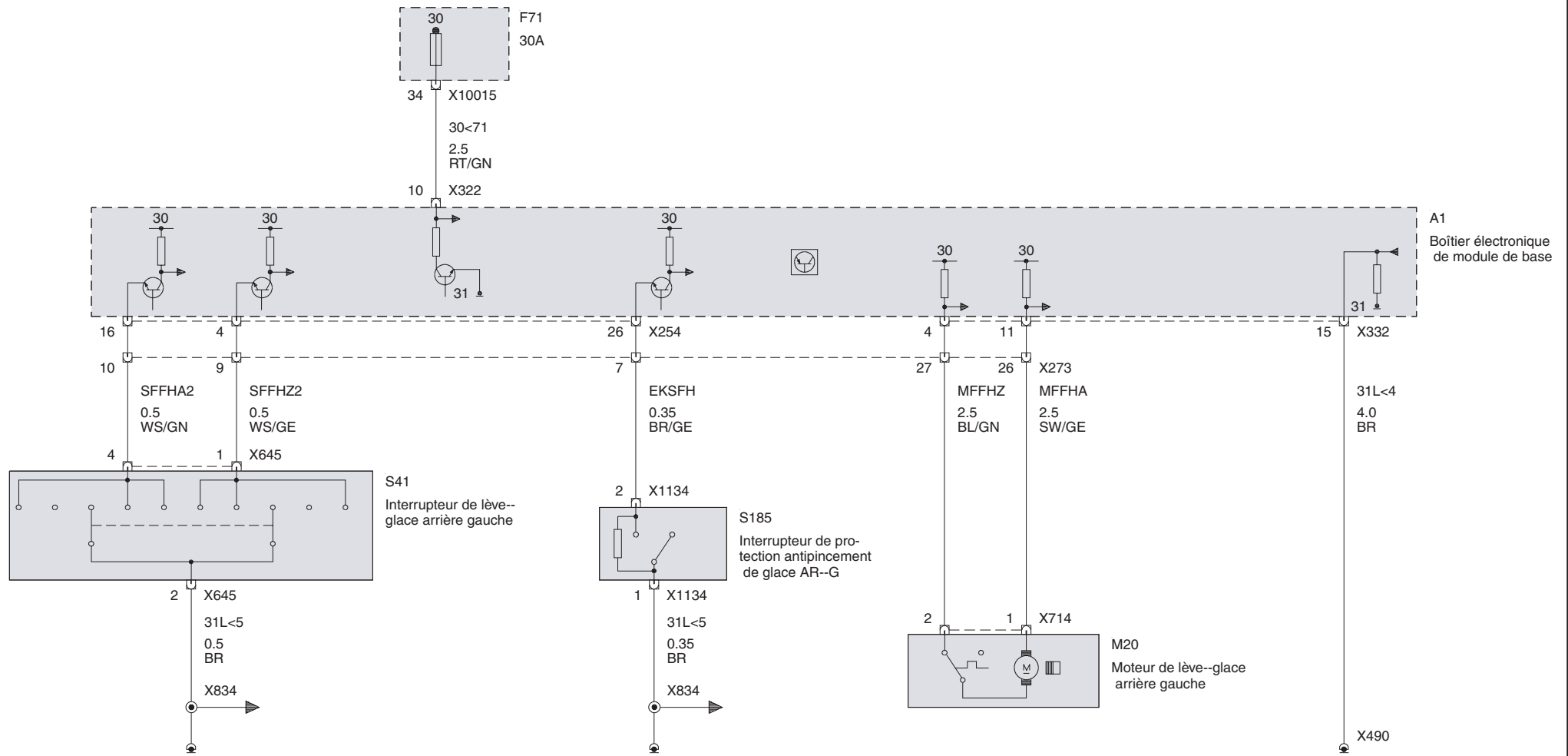



Moteur de lève-glace arrière côté passager

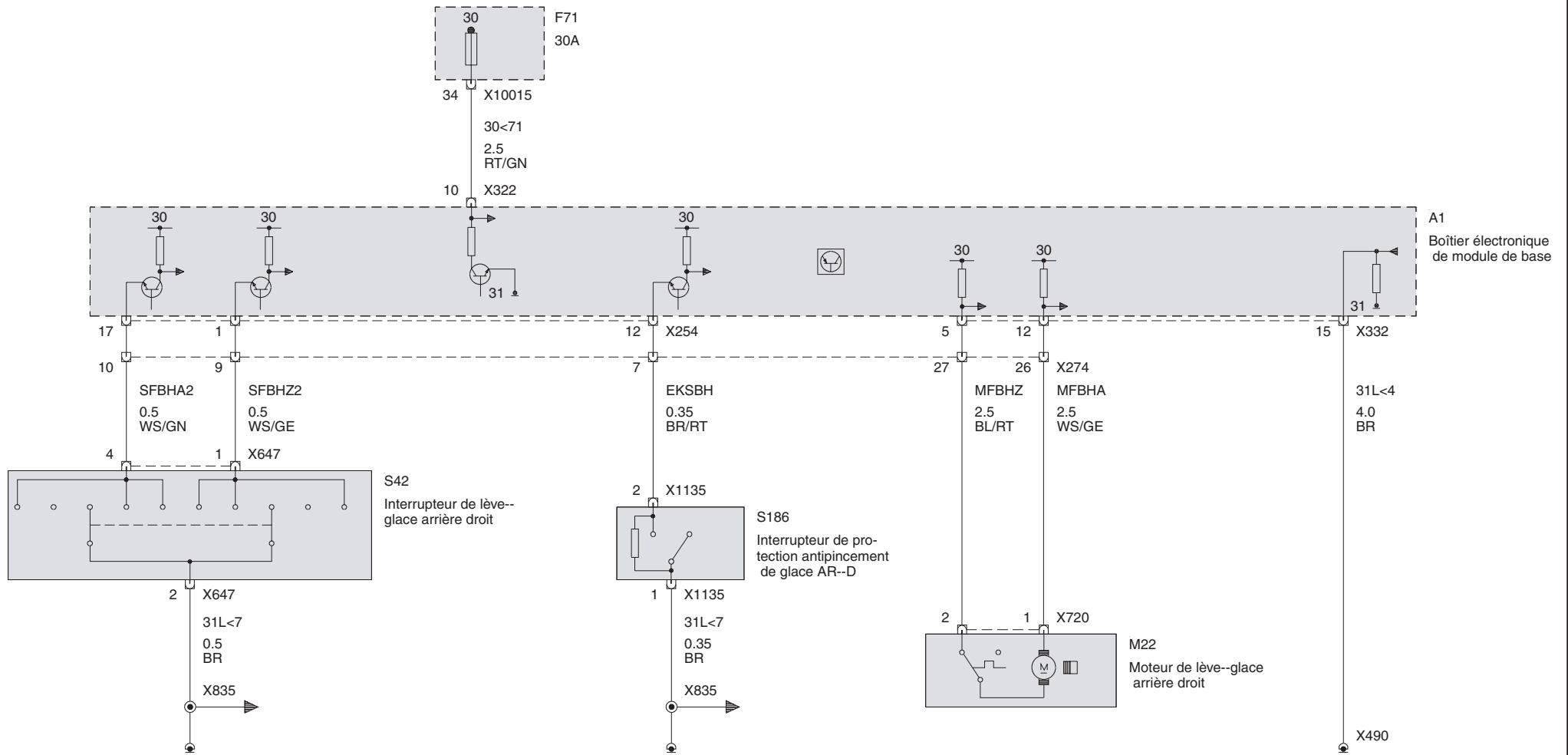

Vitre de custode

Vitre de custode entr'ouvrable (Coupé)

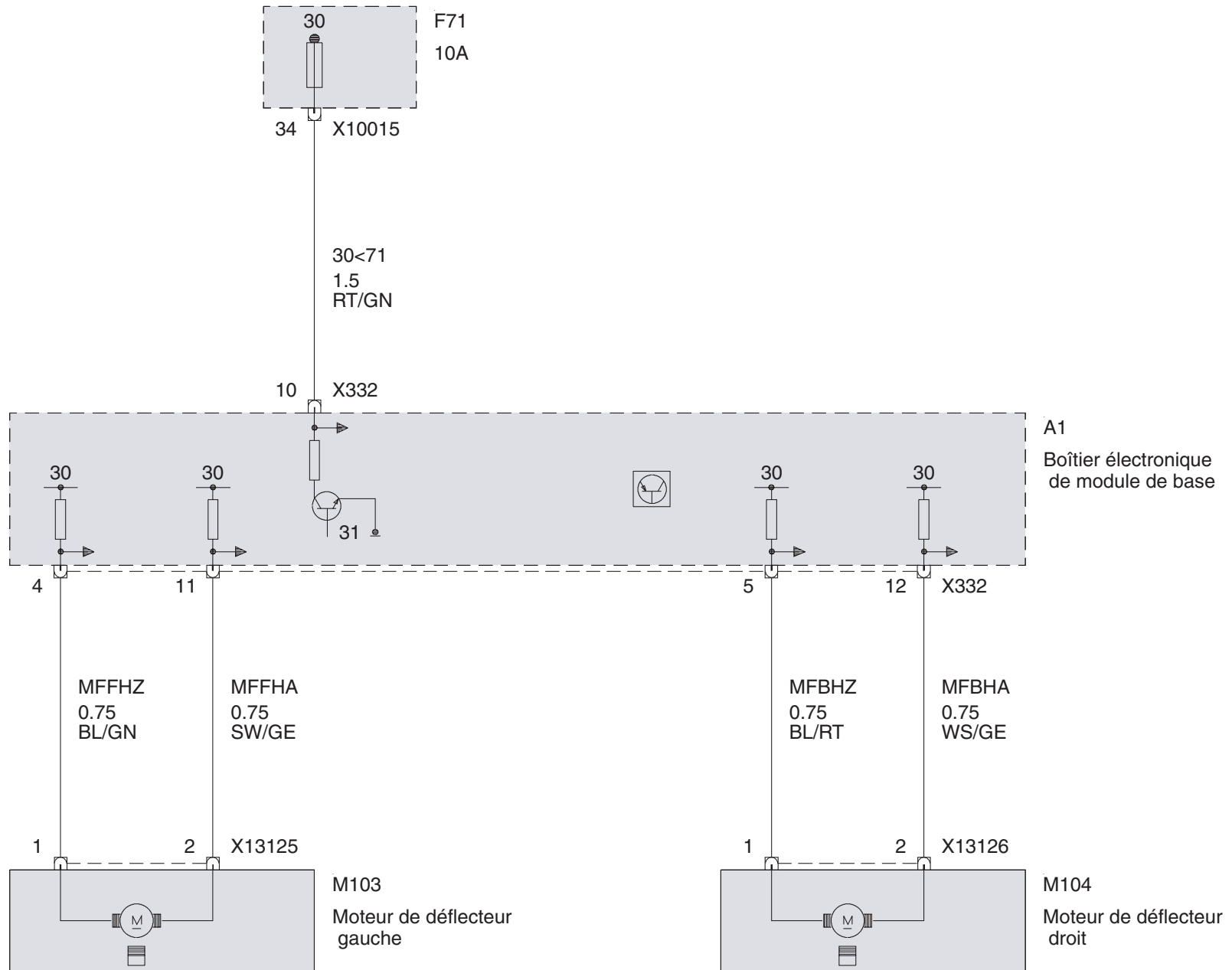

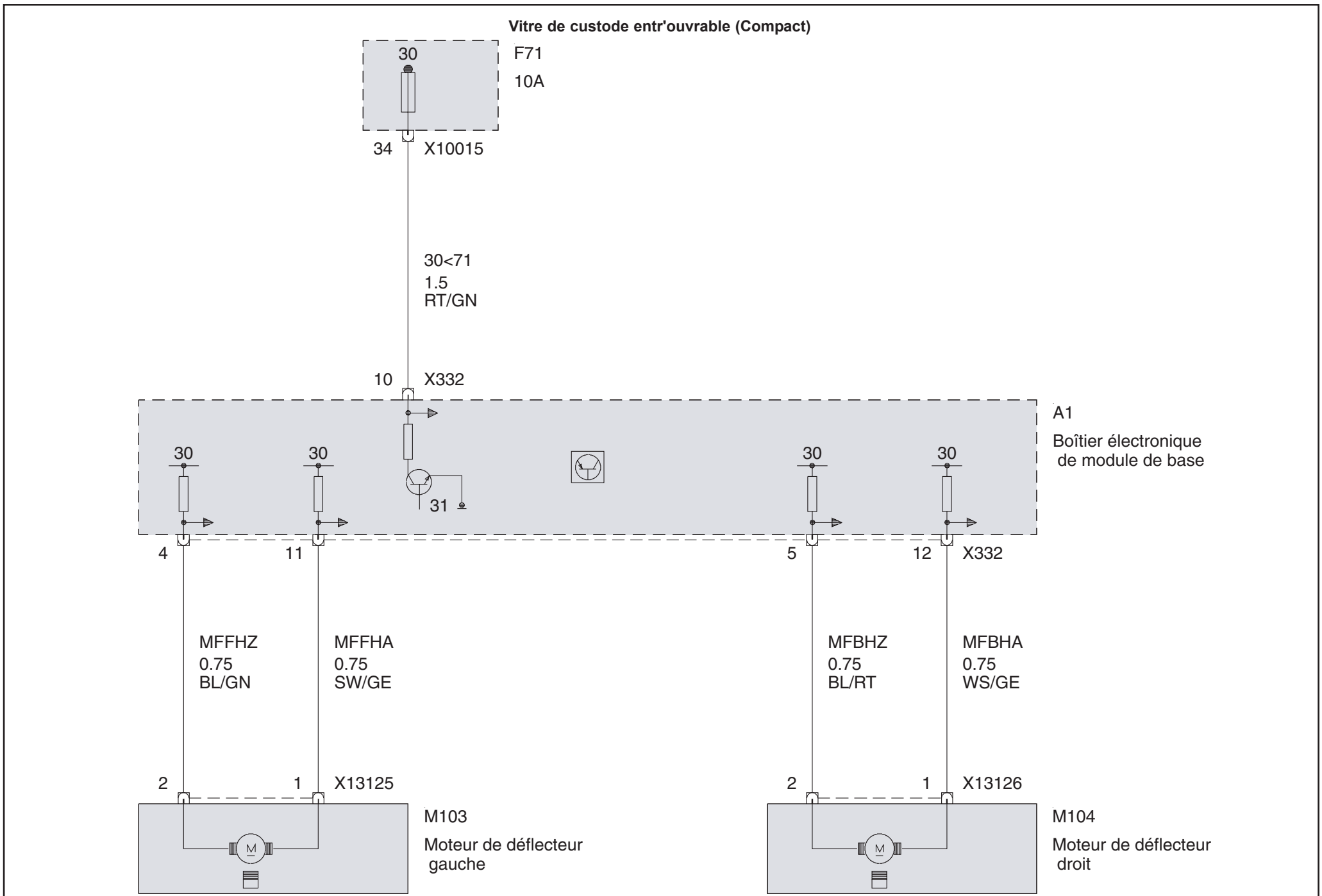

Toit ouvrant inclinable

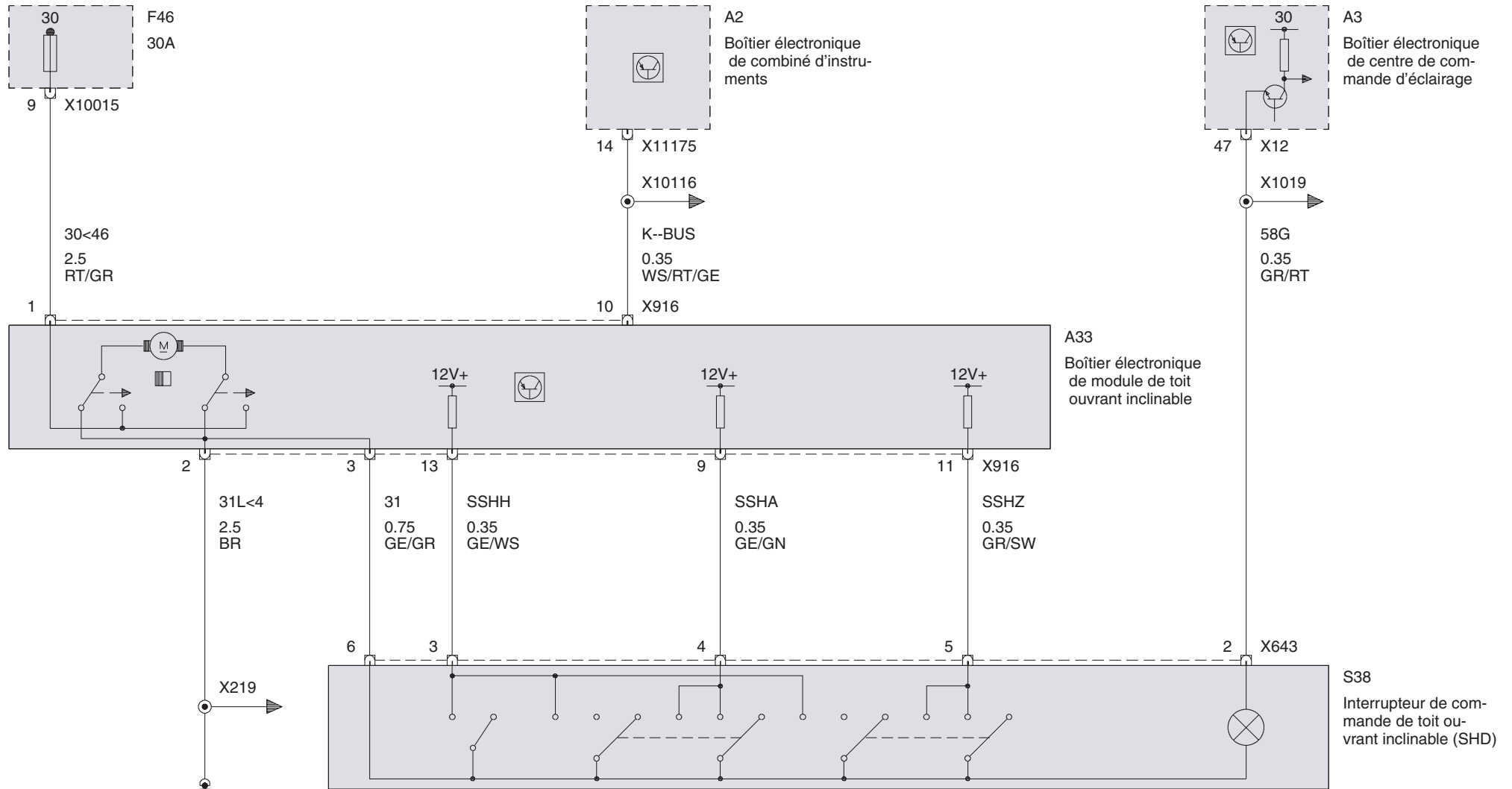

**Verrouillage centralisé**  
 Verrouillage centralisé (Berline avec Radiocommande)

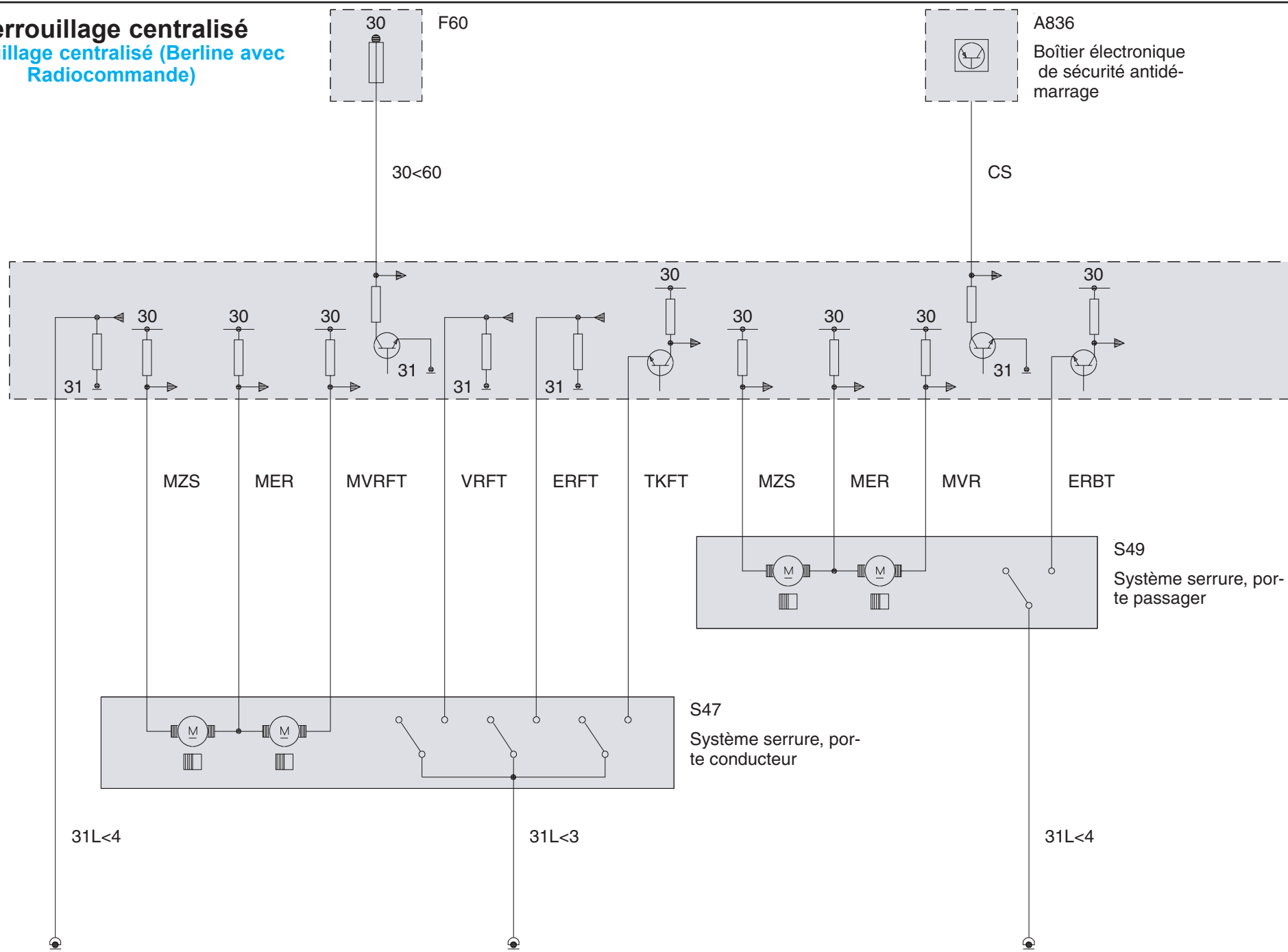

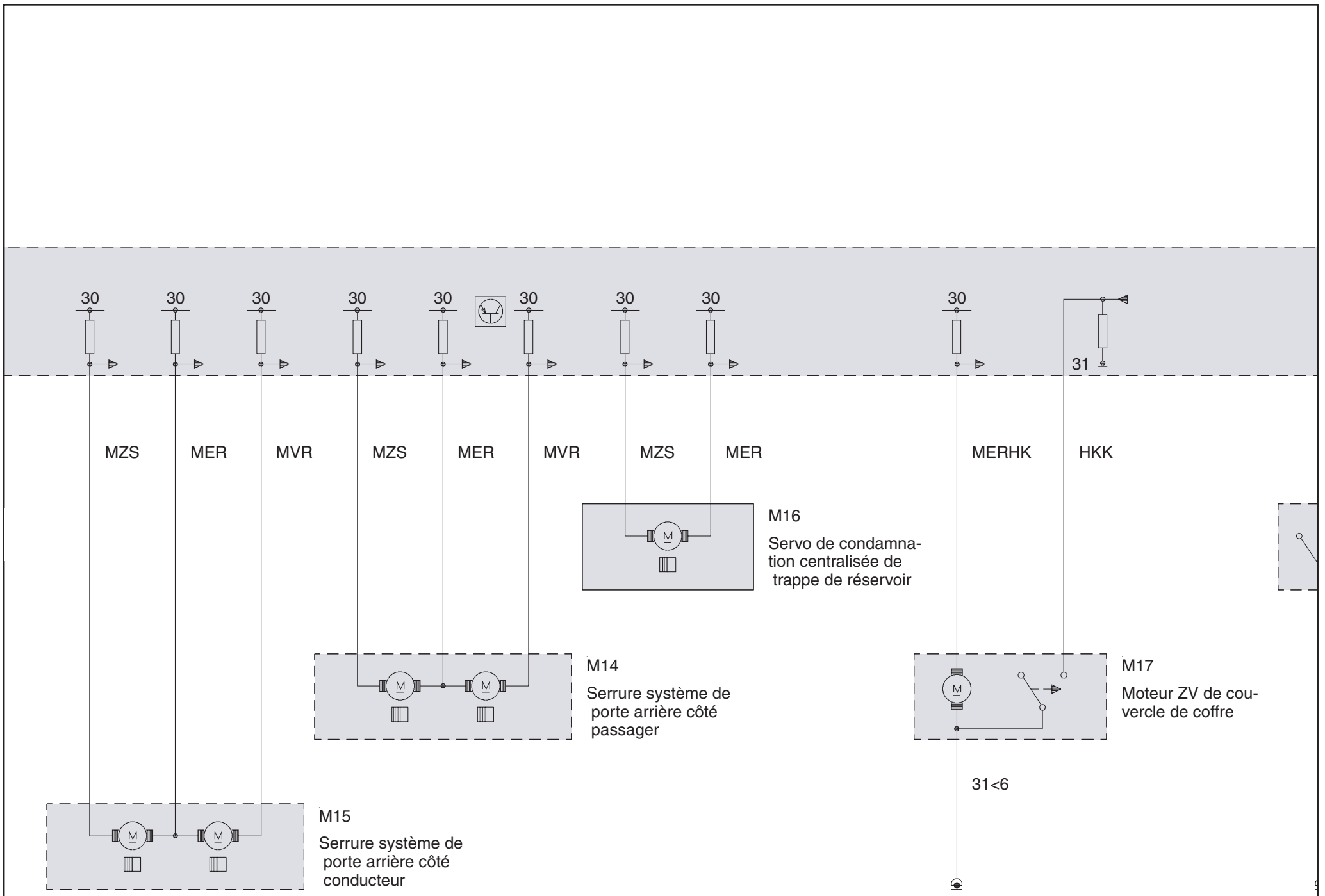

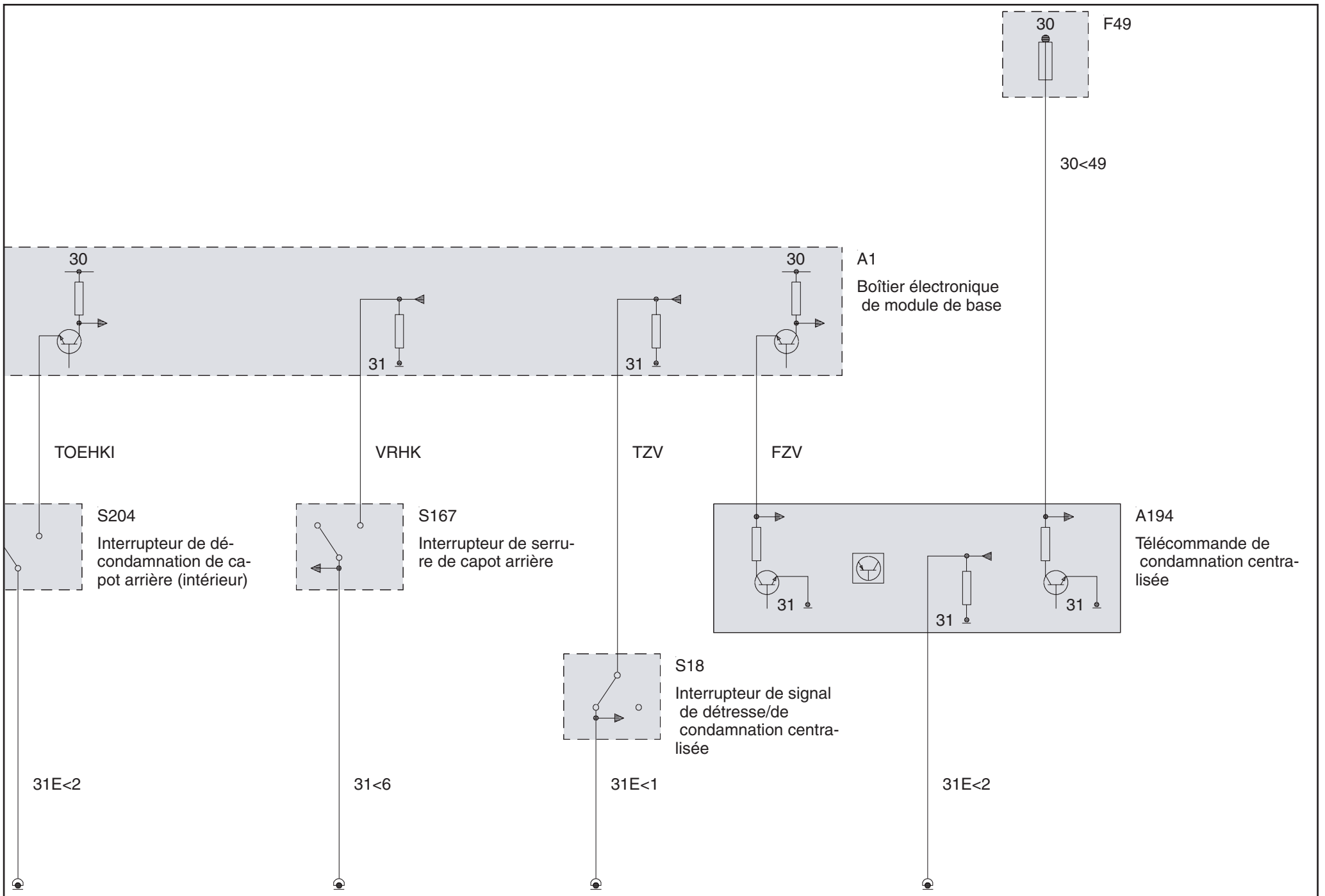

Verrouillage centralisé (Berline avec Télécommande à infrarouge et Boîte automatique)

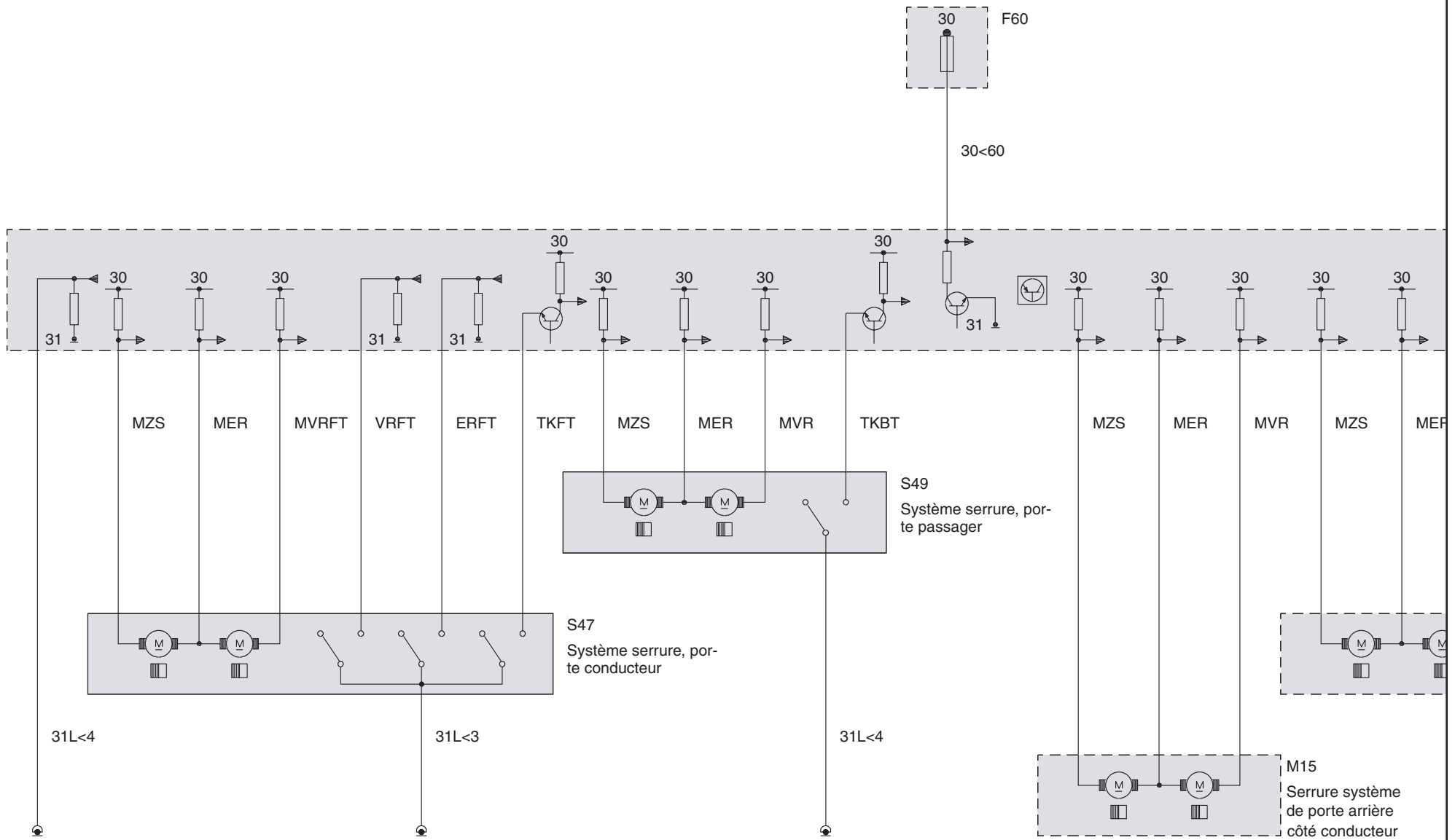



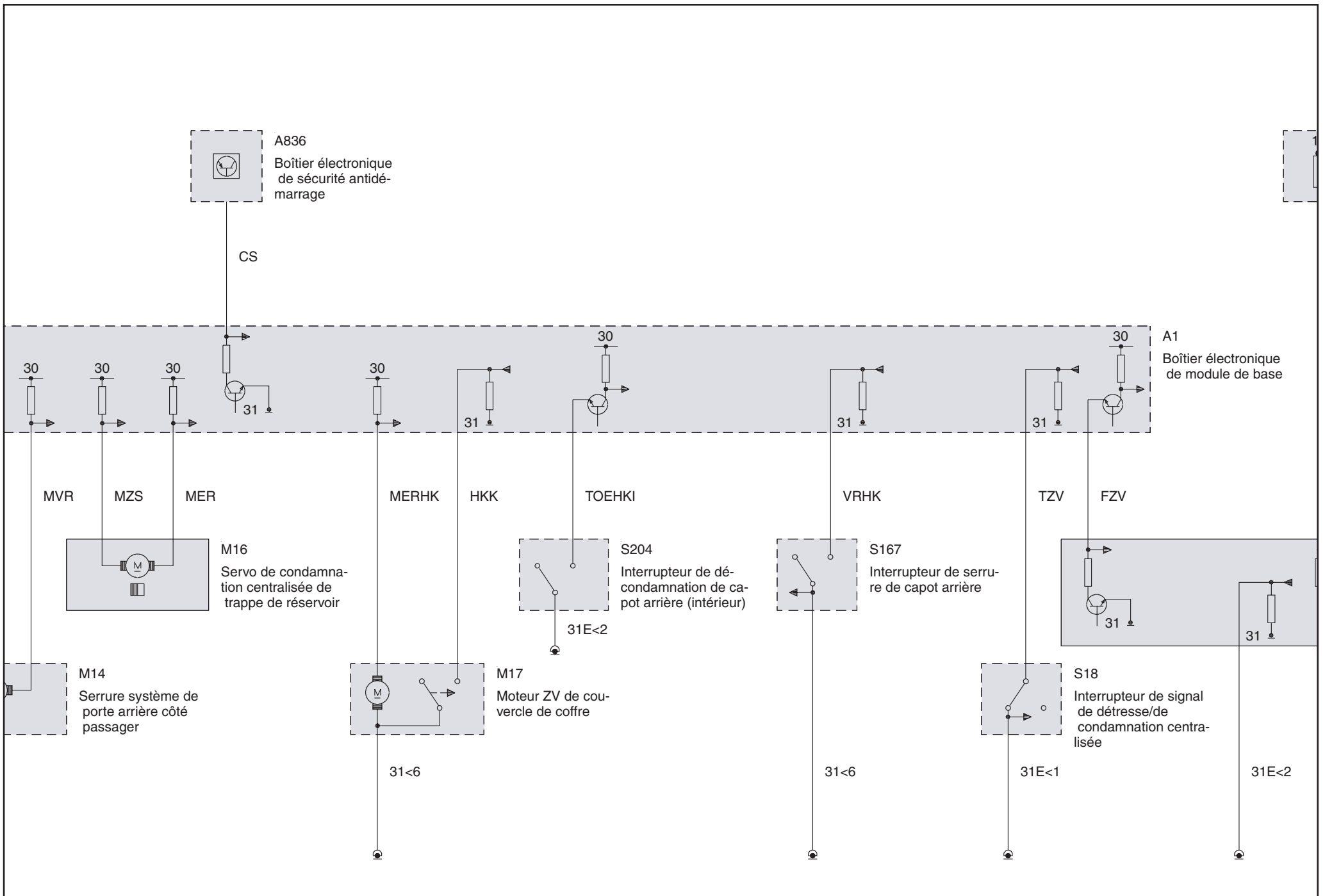

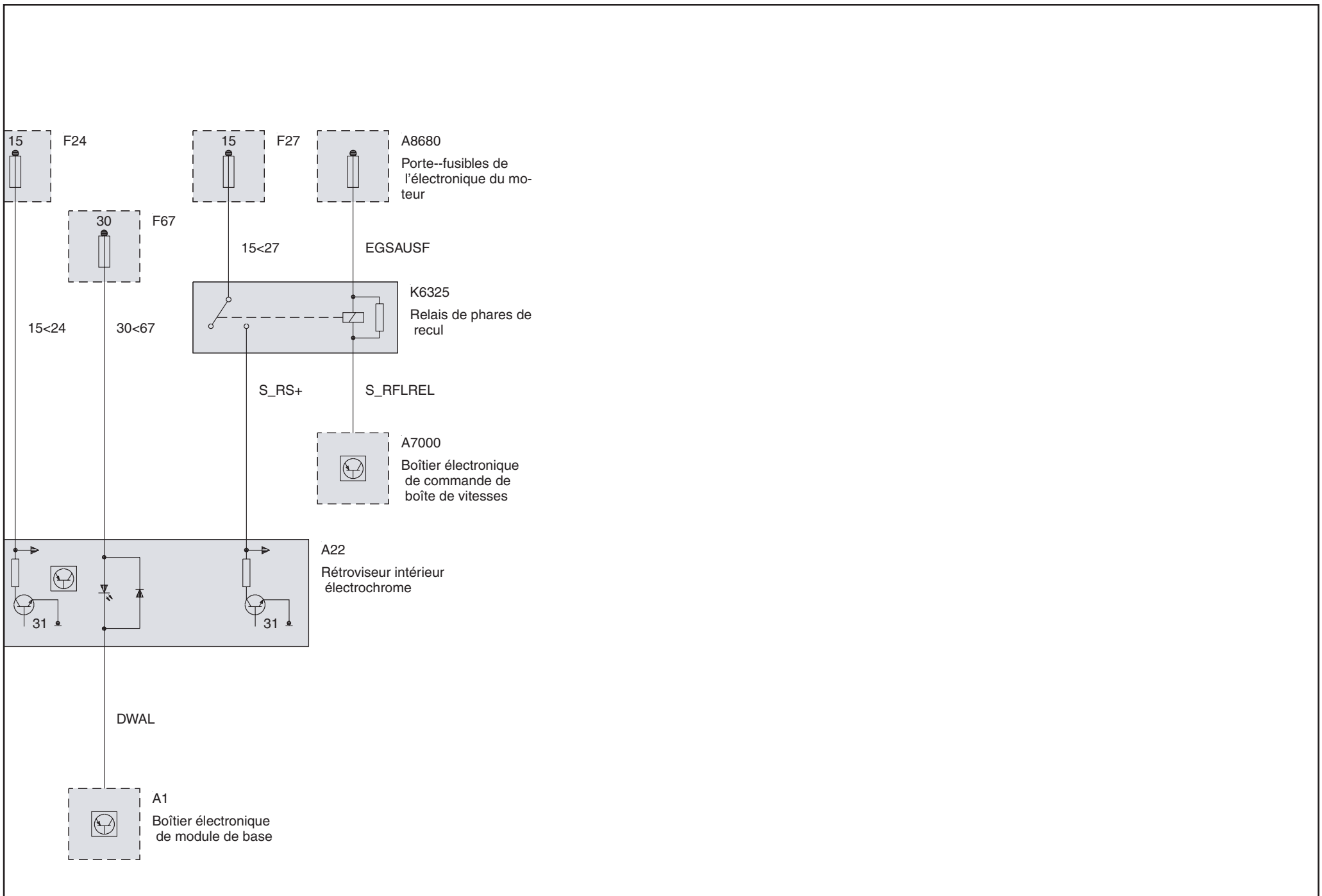

Verrouillage centralisé (Berline Diesel avec Télécommande à infrarouge, sans Boîte automatique)

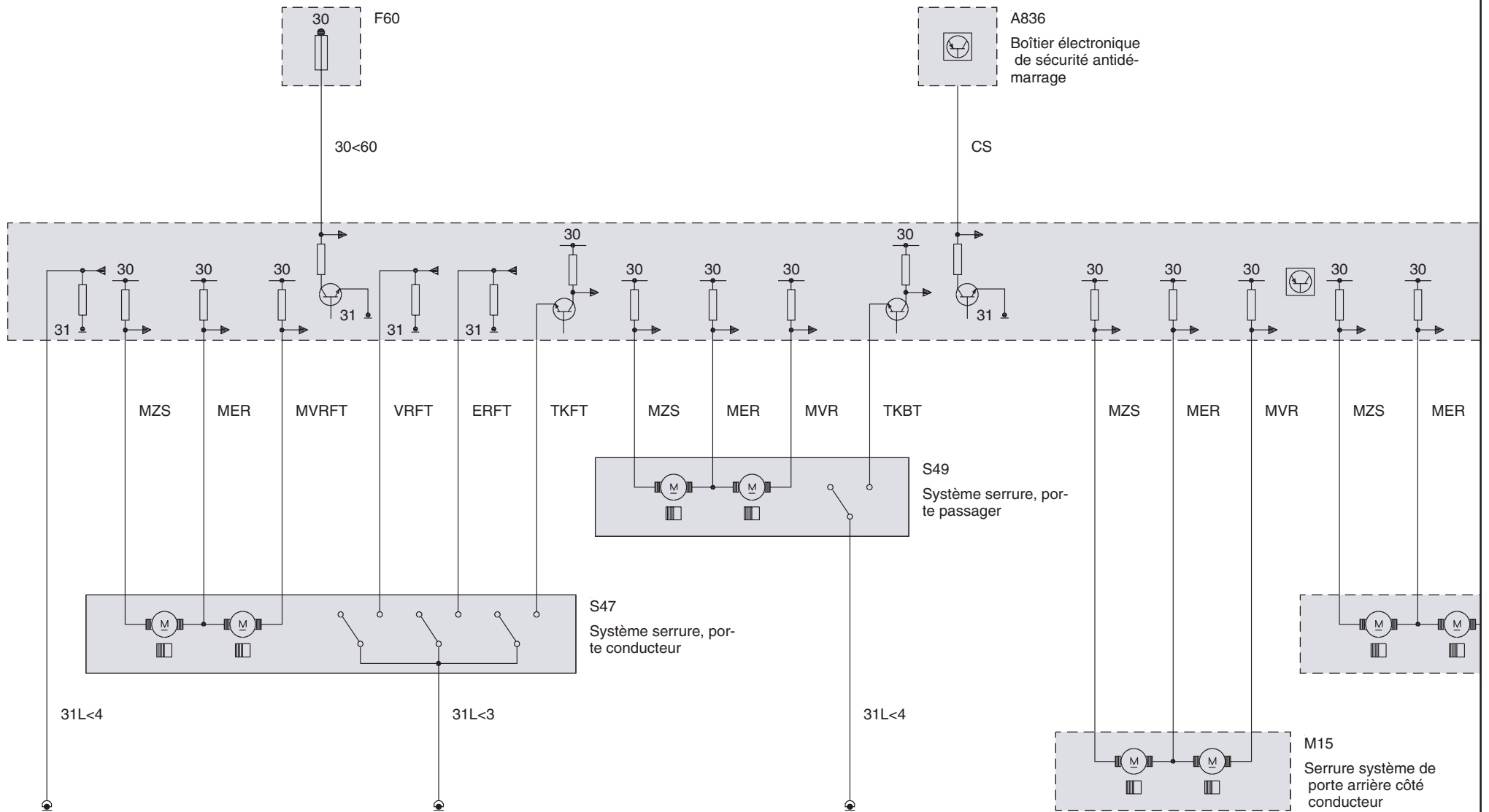

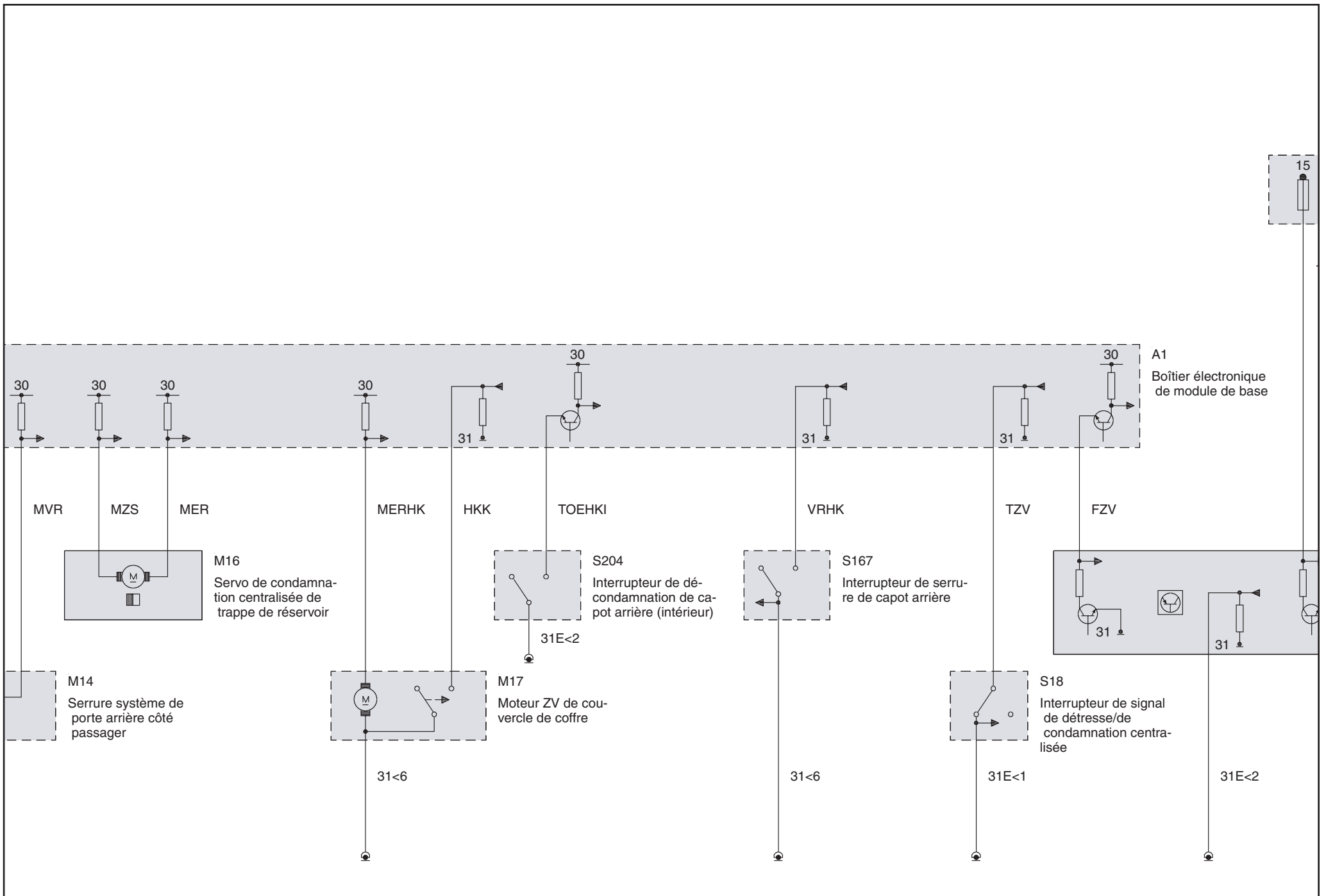

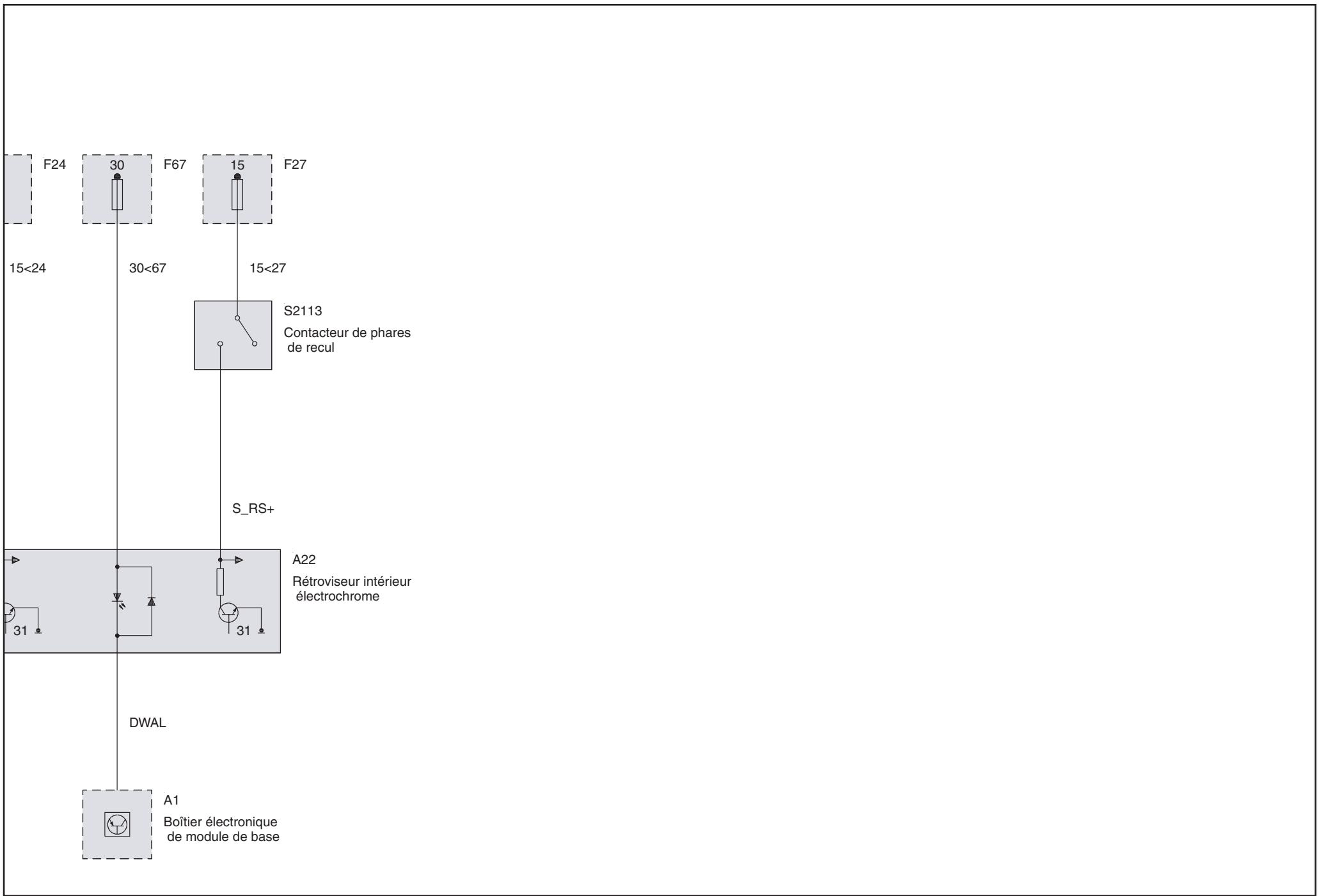

Verrouillage centralisé (Berline Essence avec Télécommande à infrarouge, sans Boîte automatique)

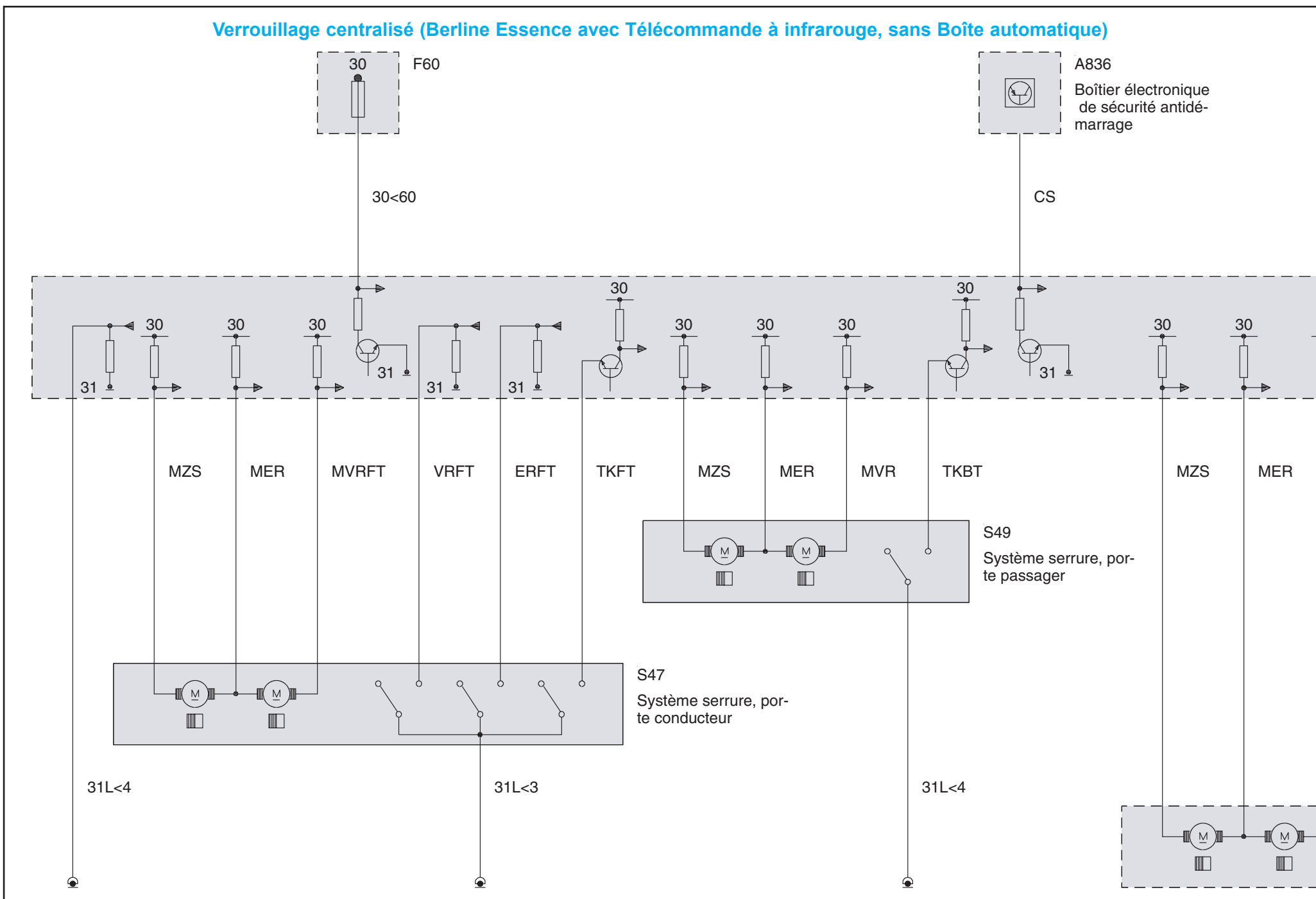

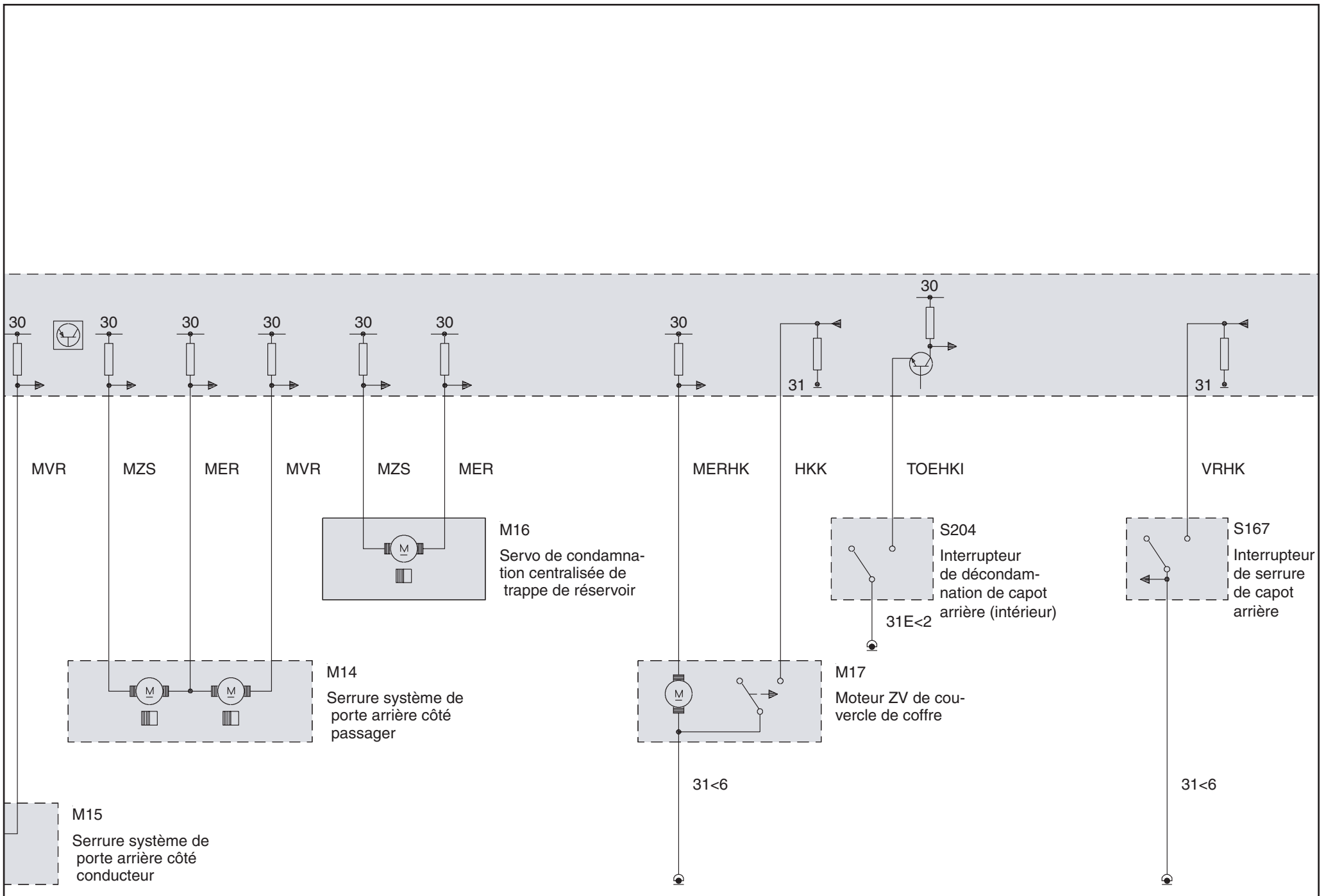

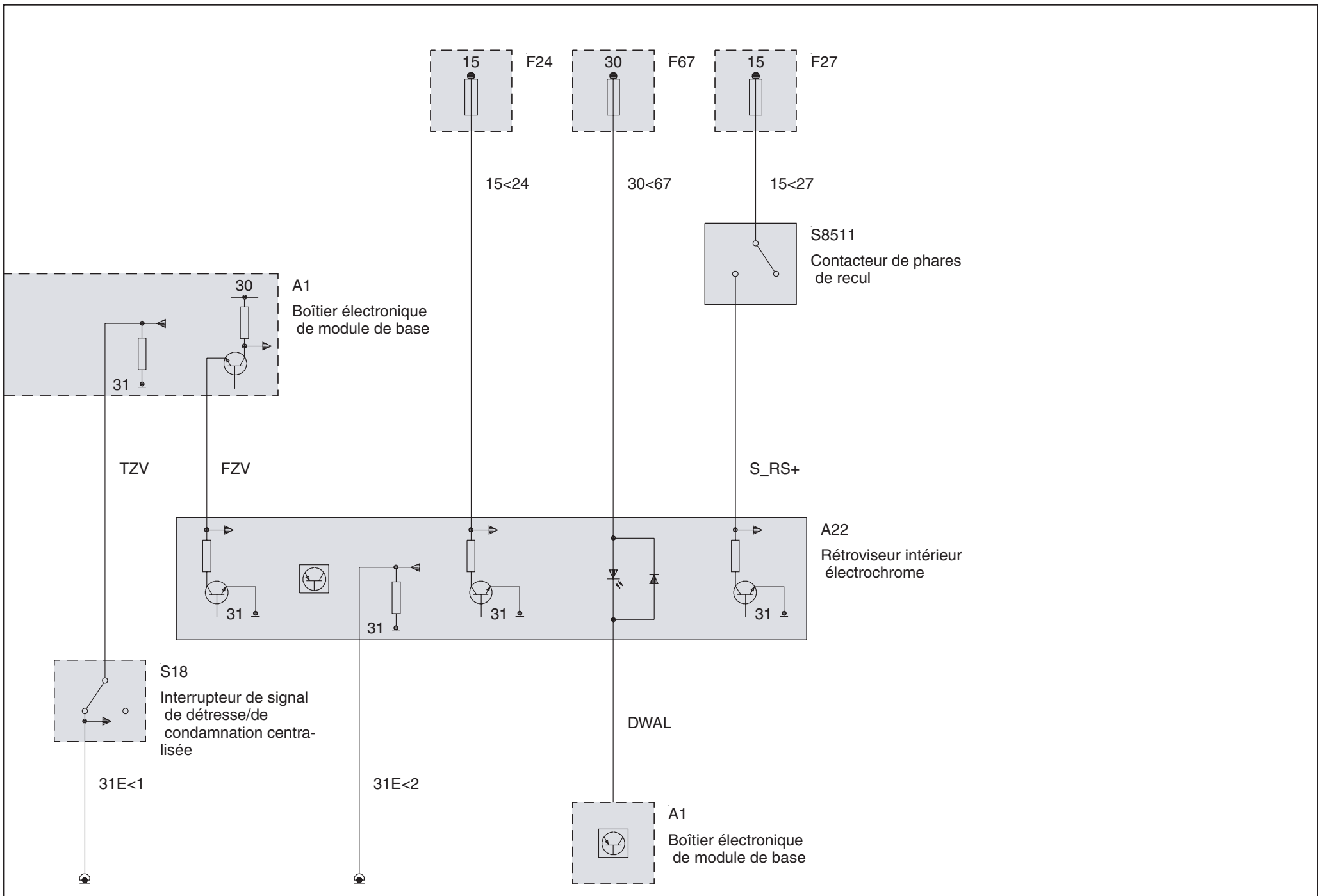



Verrouillage centralisé (Touring sans Télécommande à infrarouge, sans Radiocommande)

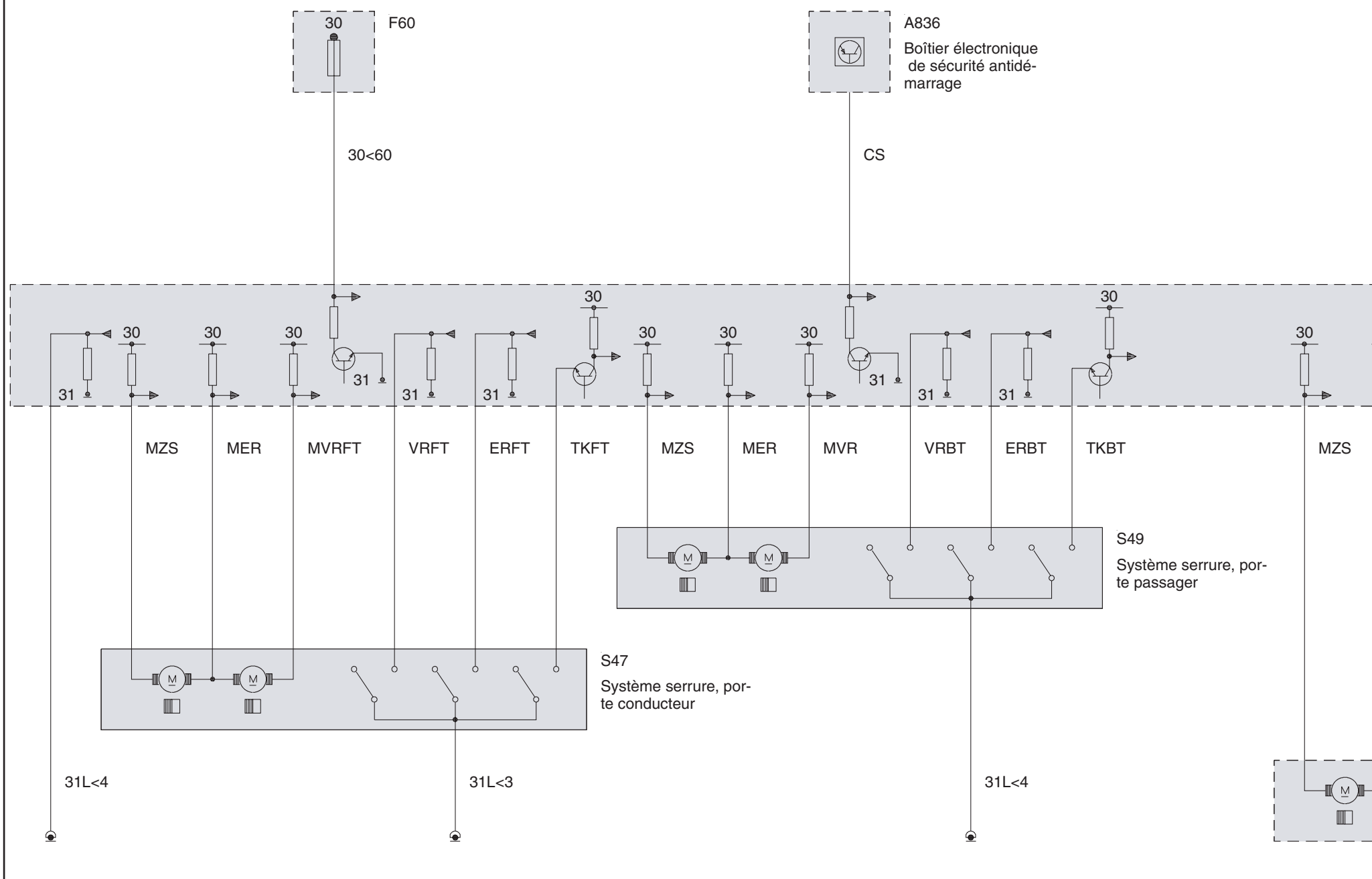

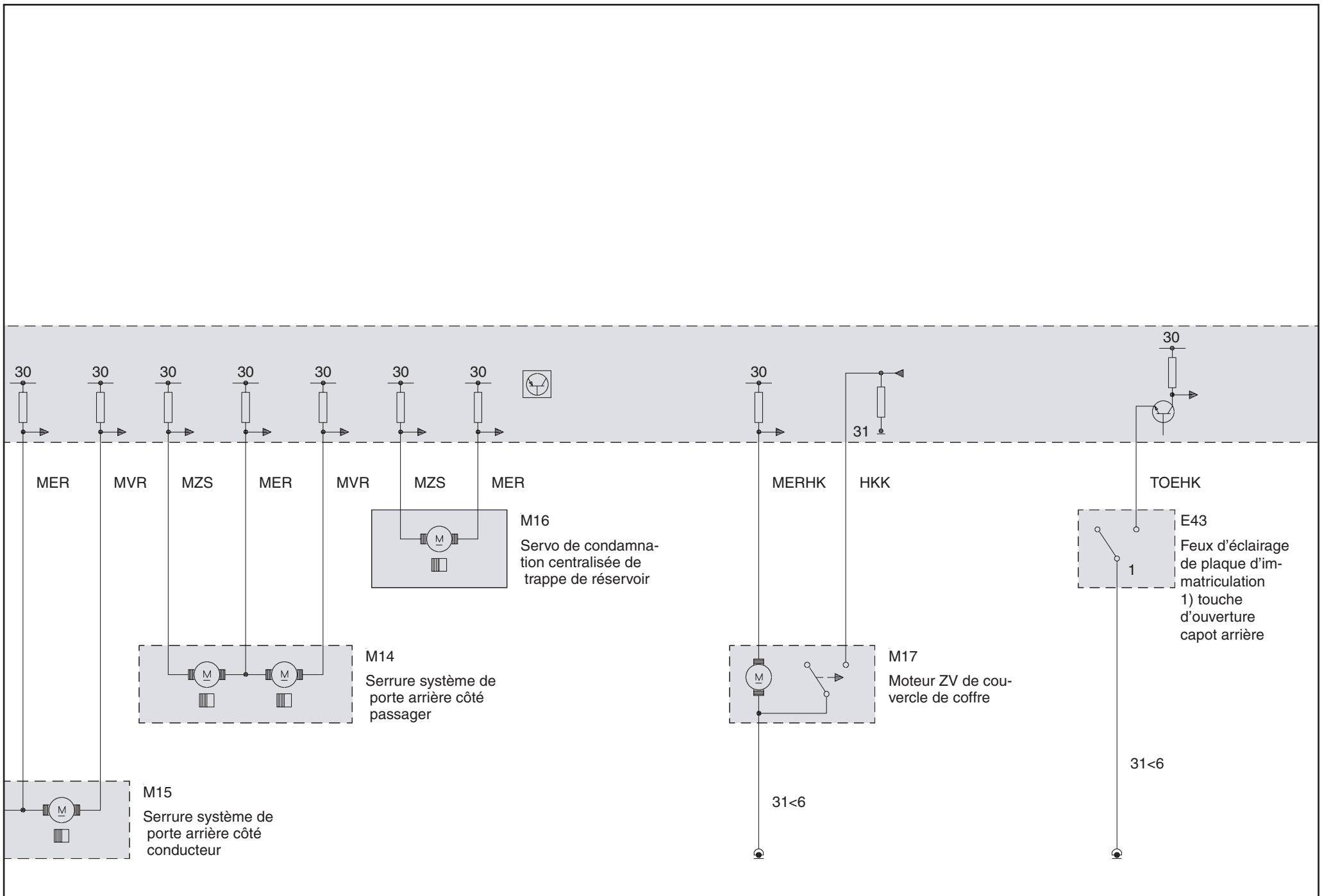

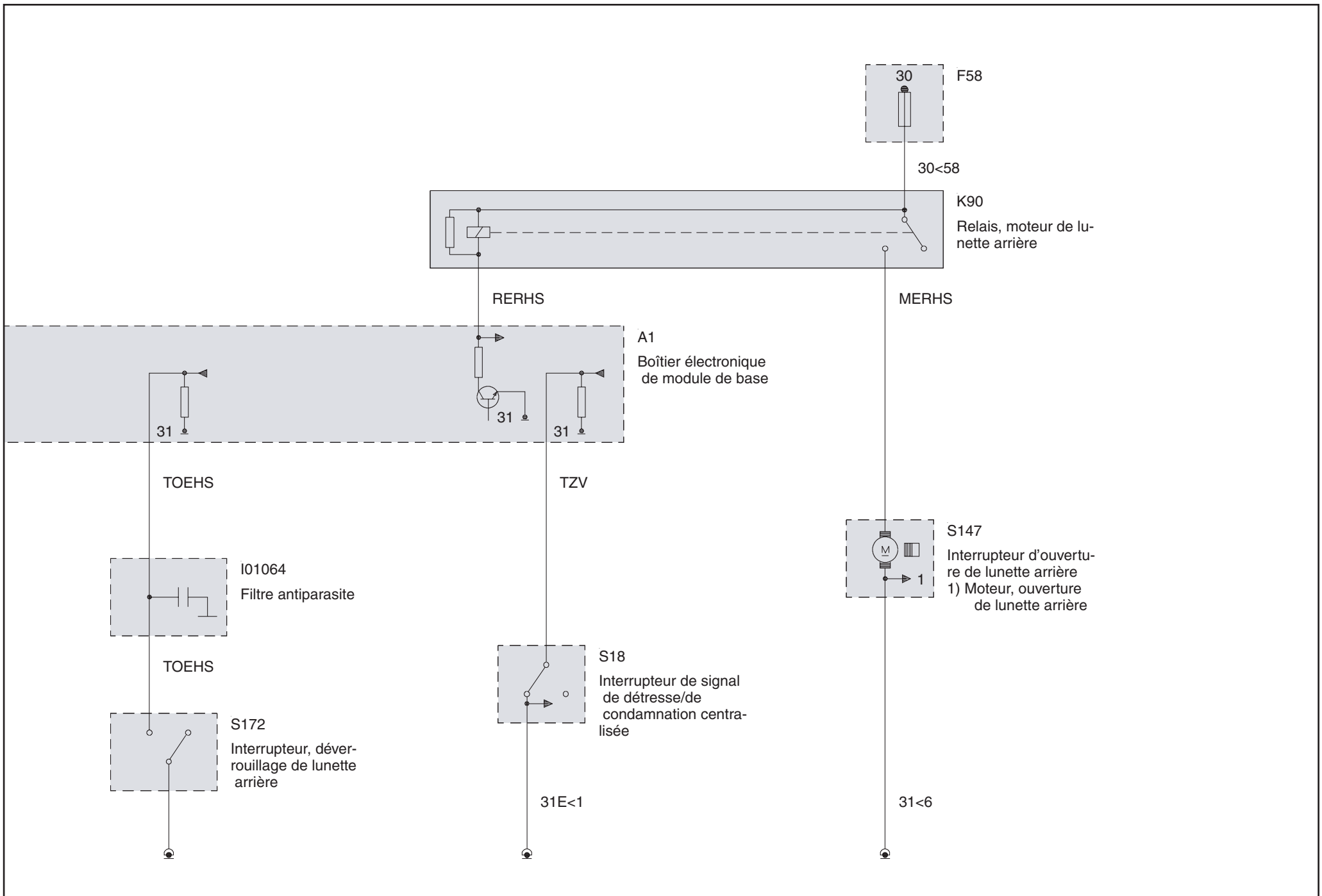

Verrouillage centralisé (Touring avec Radiocommande)

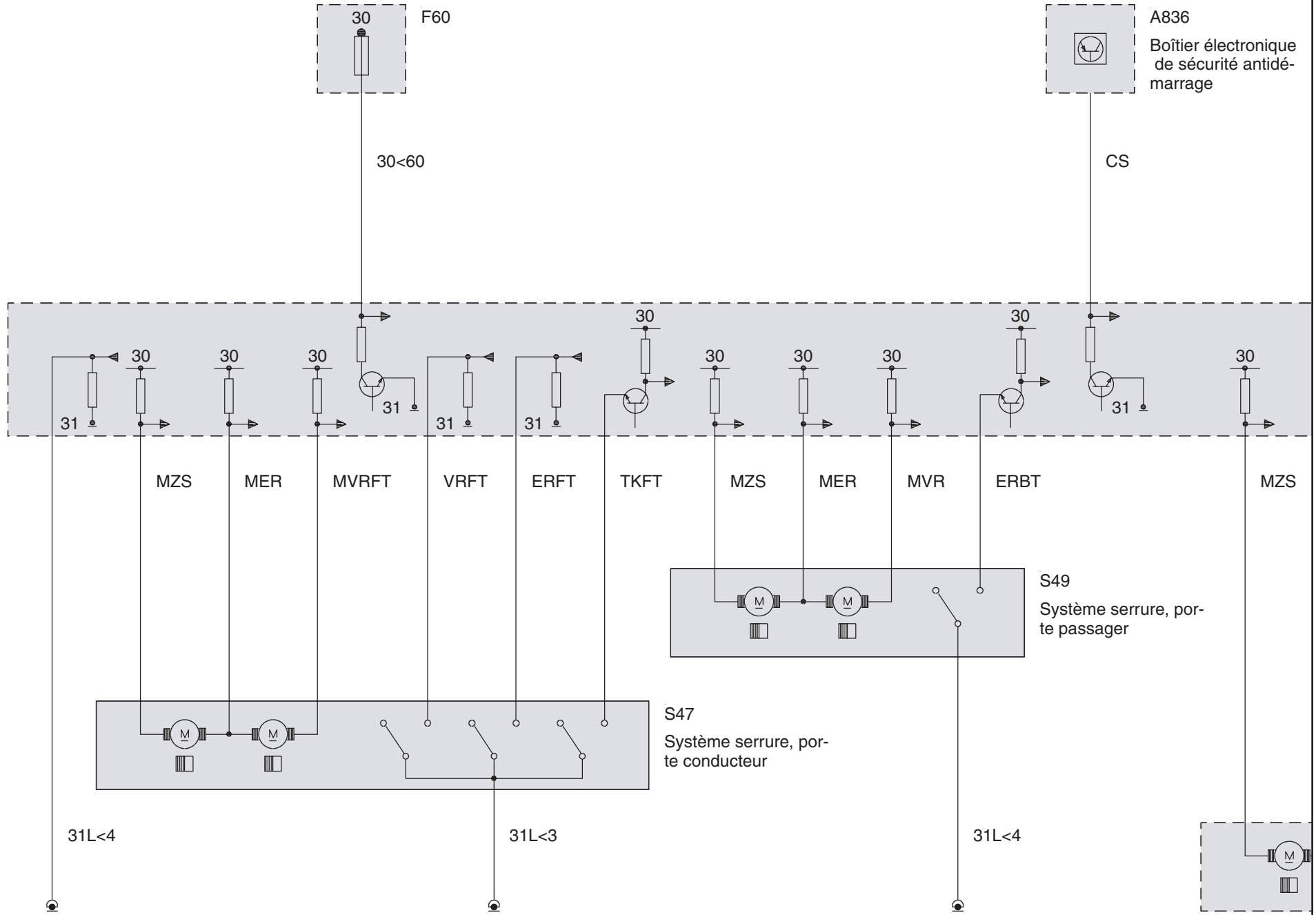

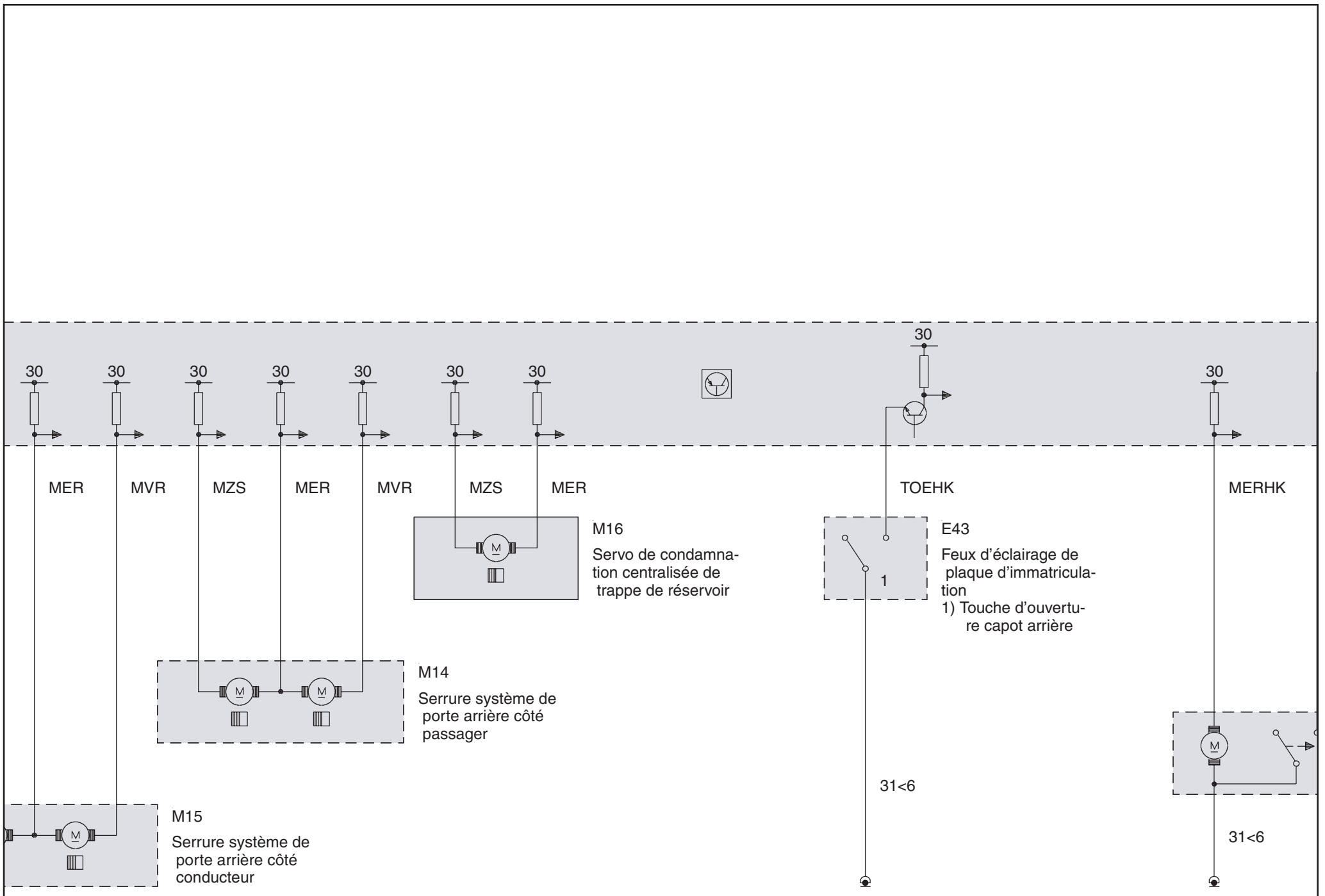

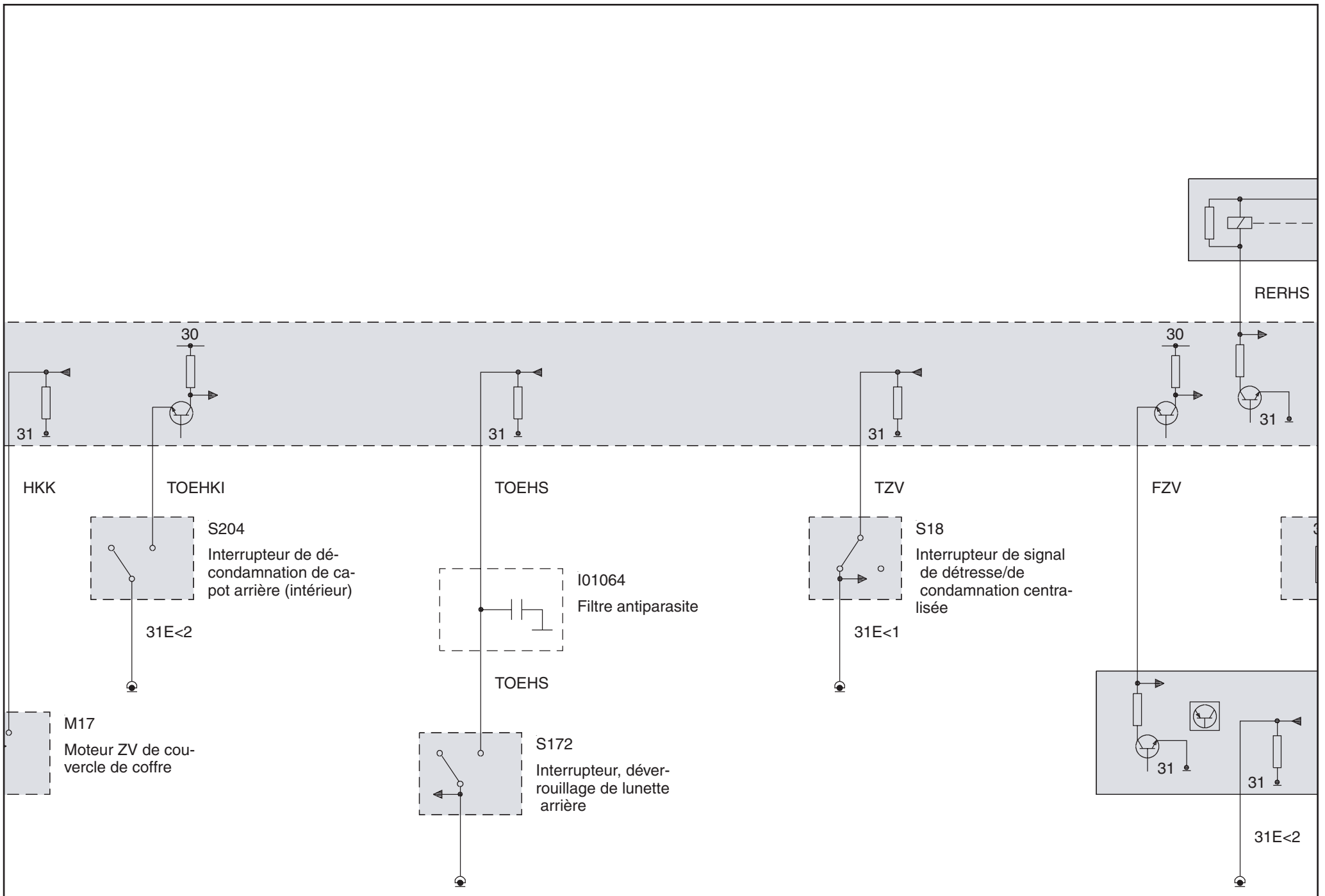

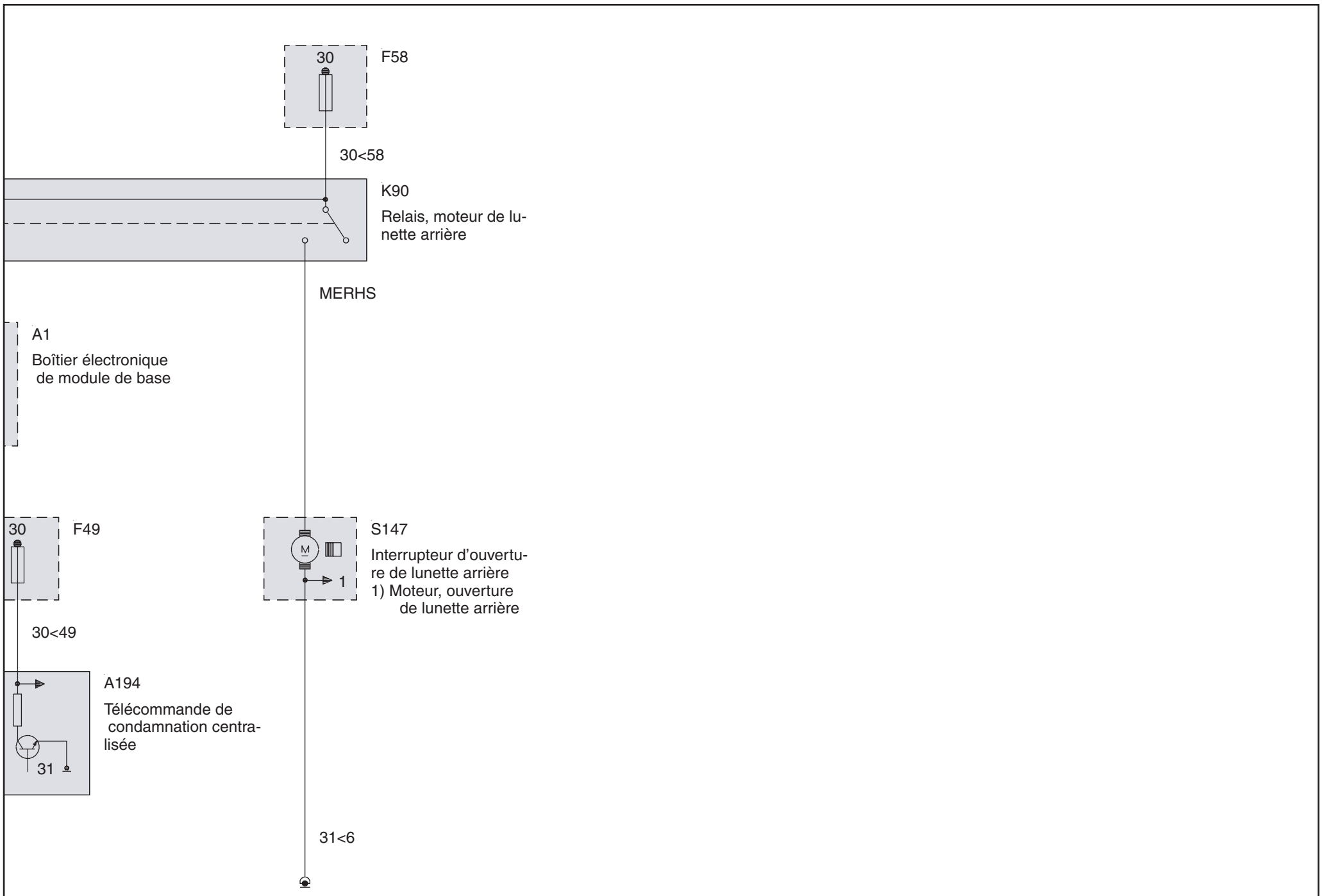

Verrouillage centralisé (Touring avec Télécommande à infrarouge et Boîte automatique)

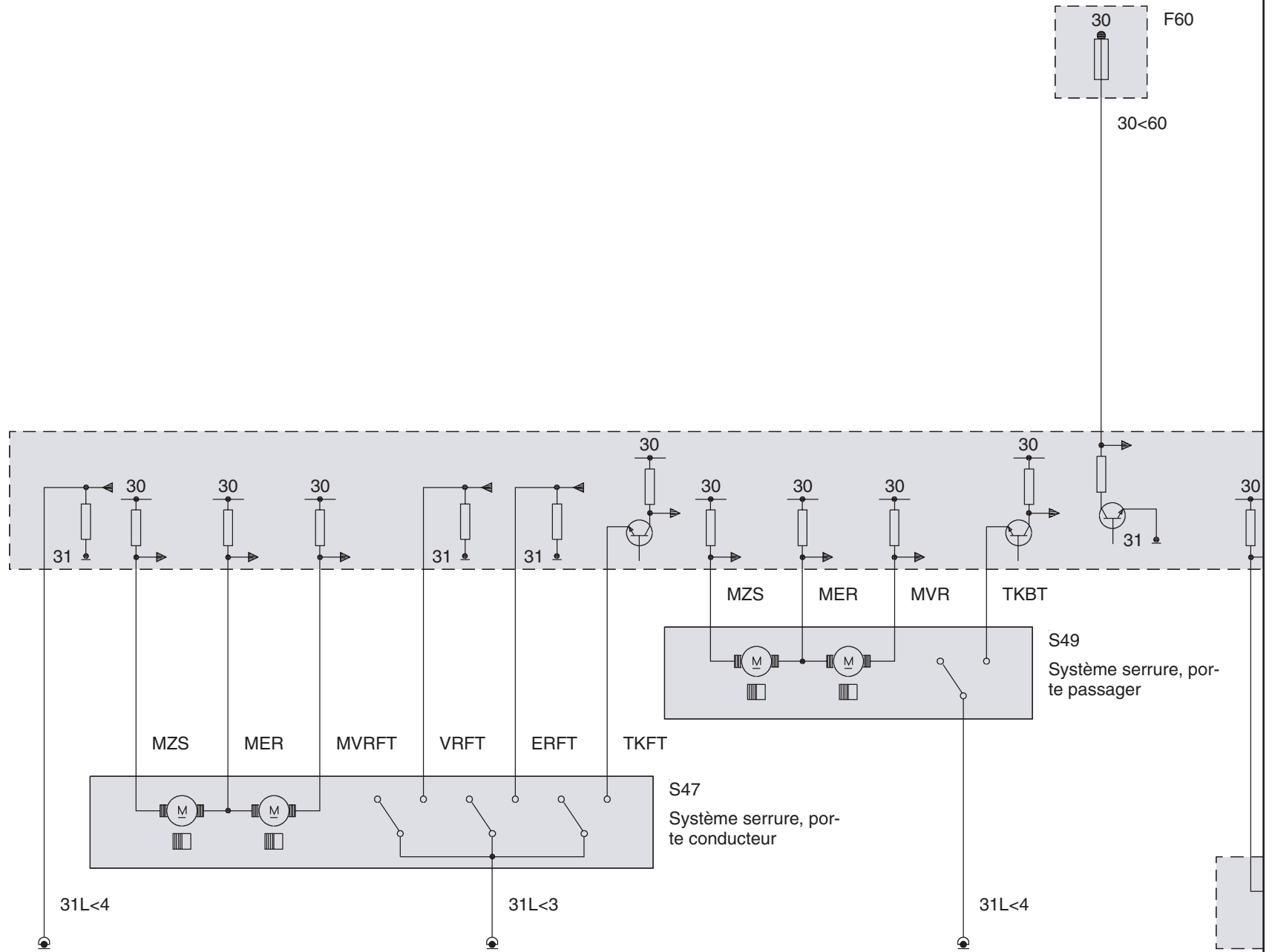



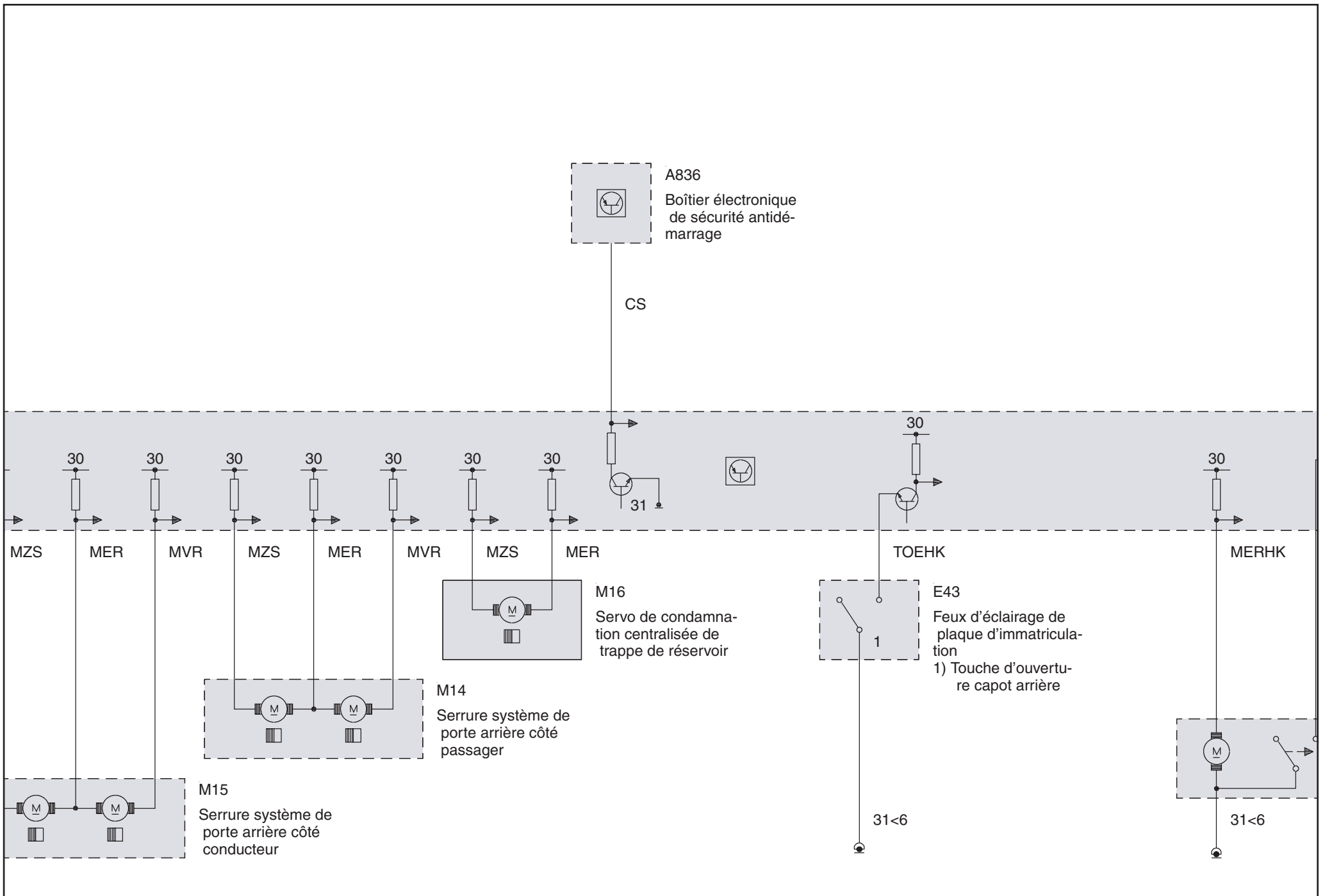

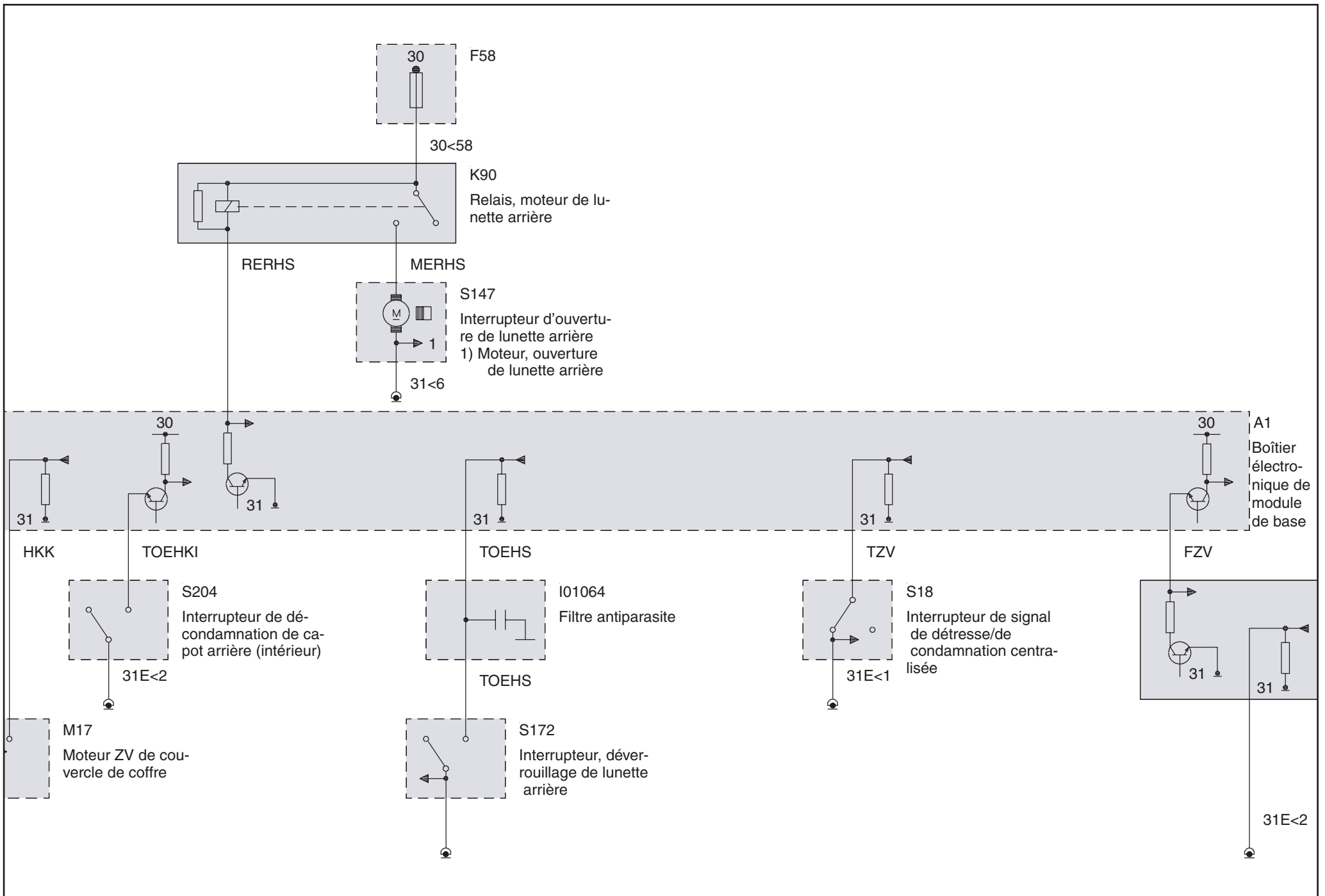

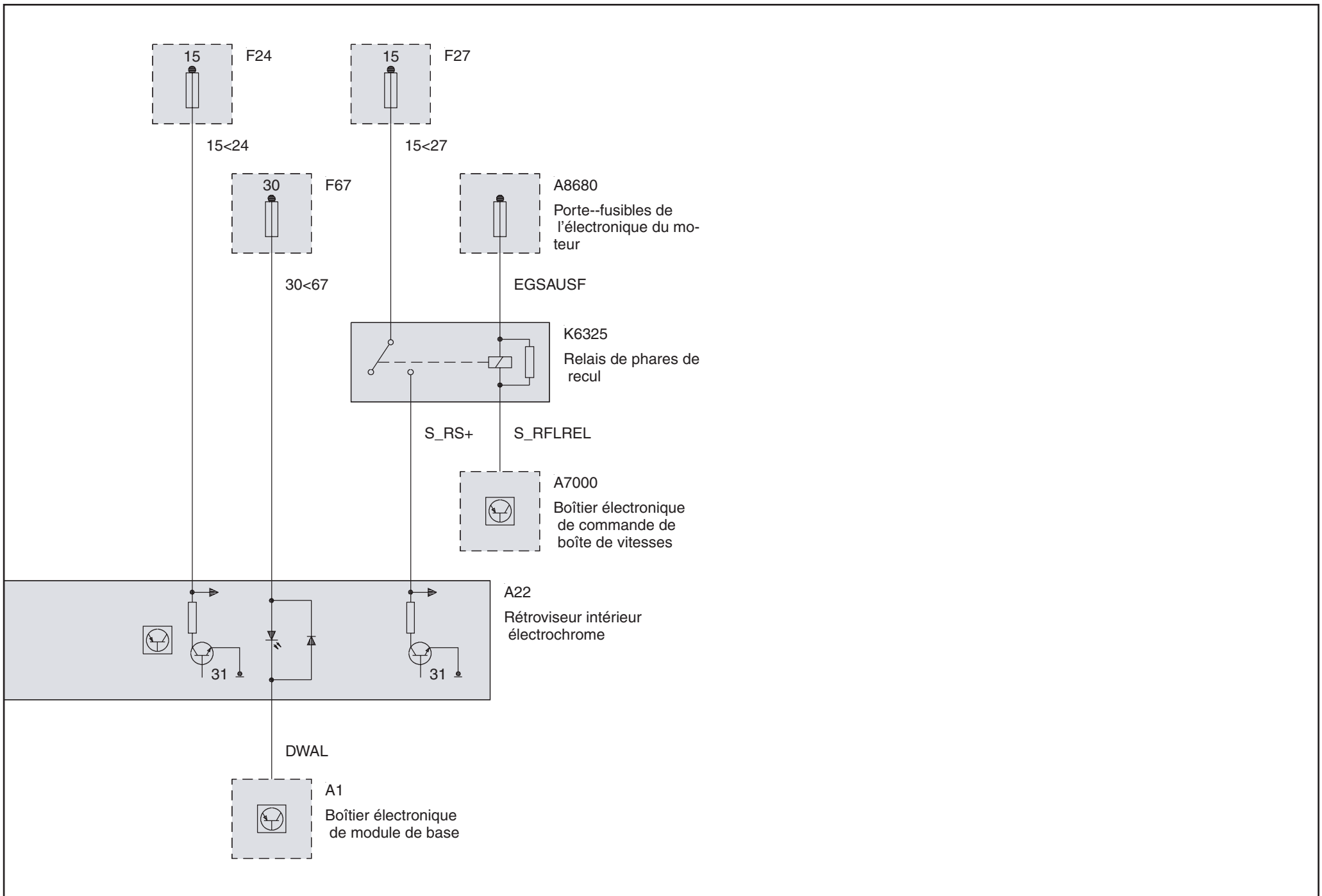



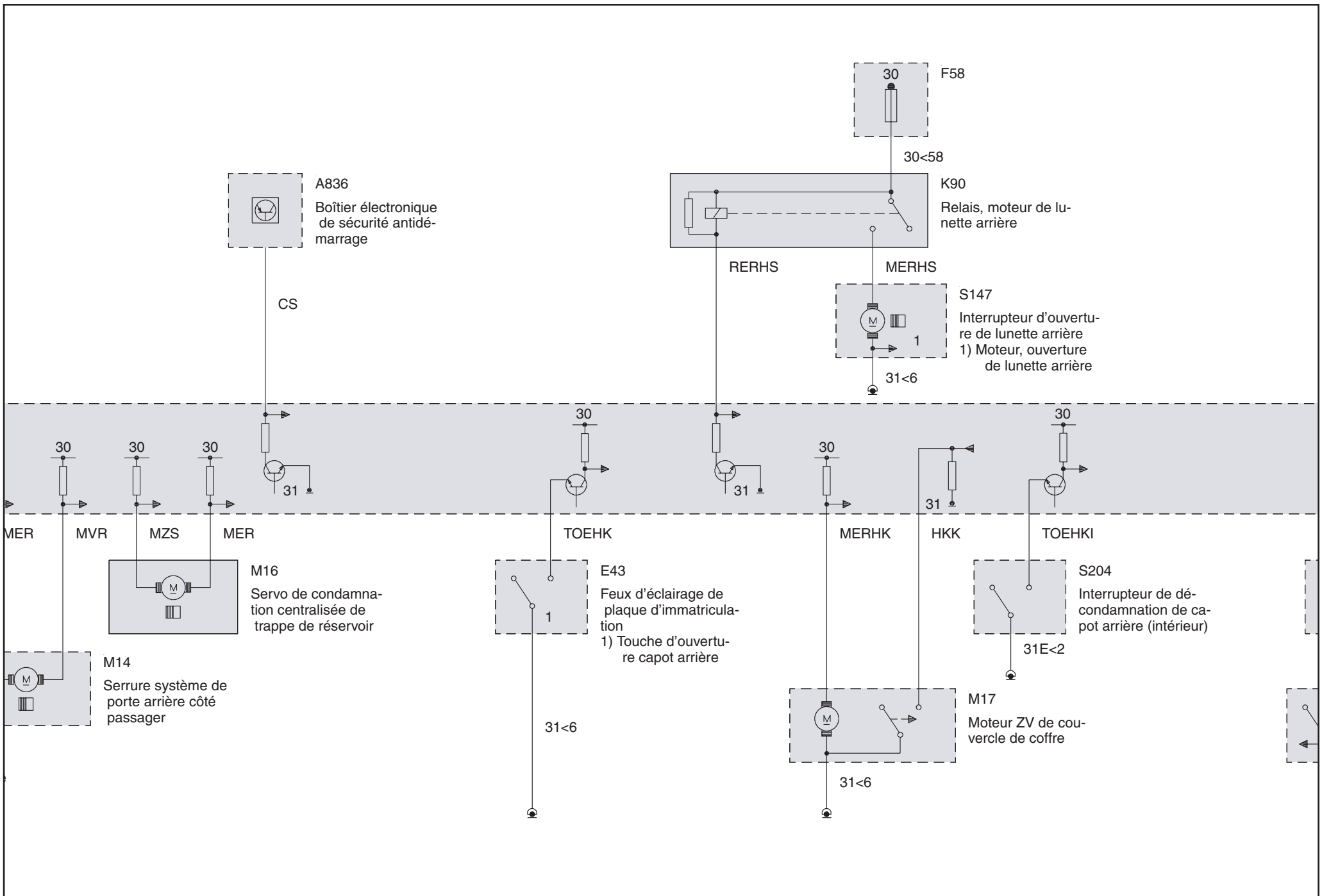

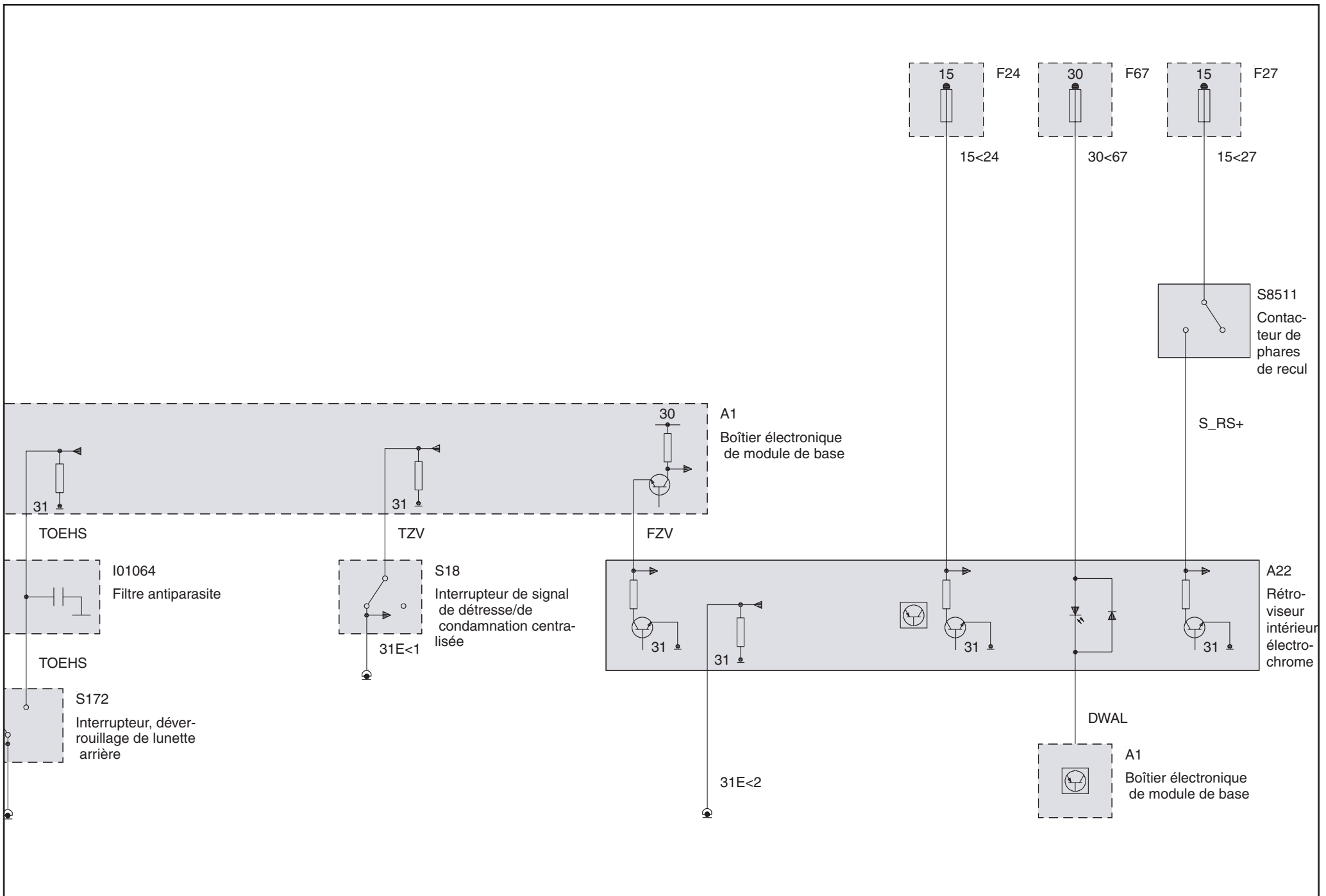

Verrouillage centralisé (Coupé ou Compact)

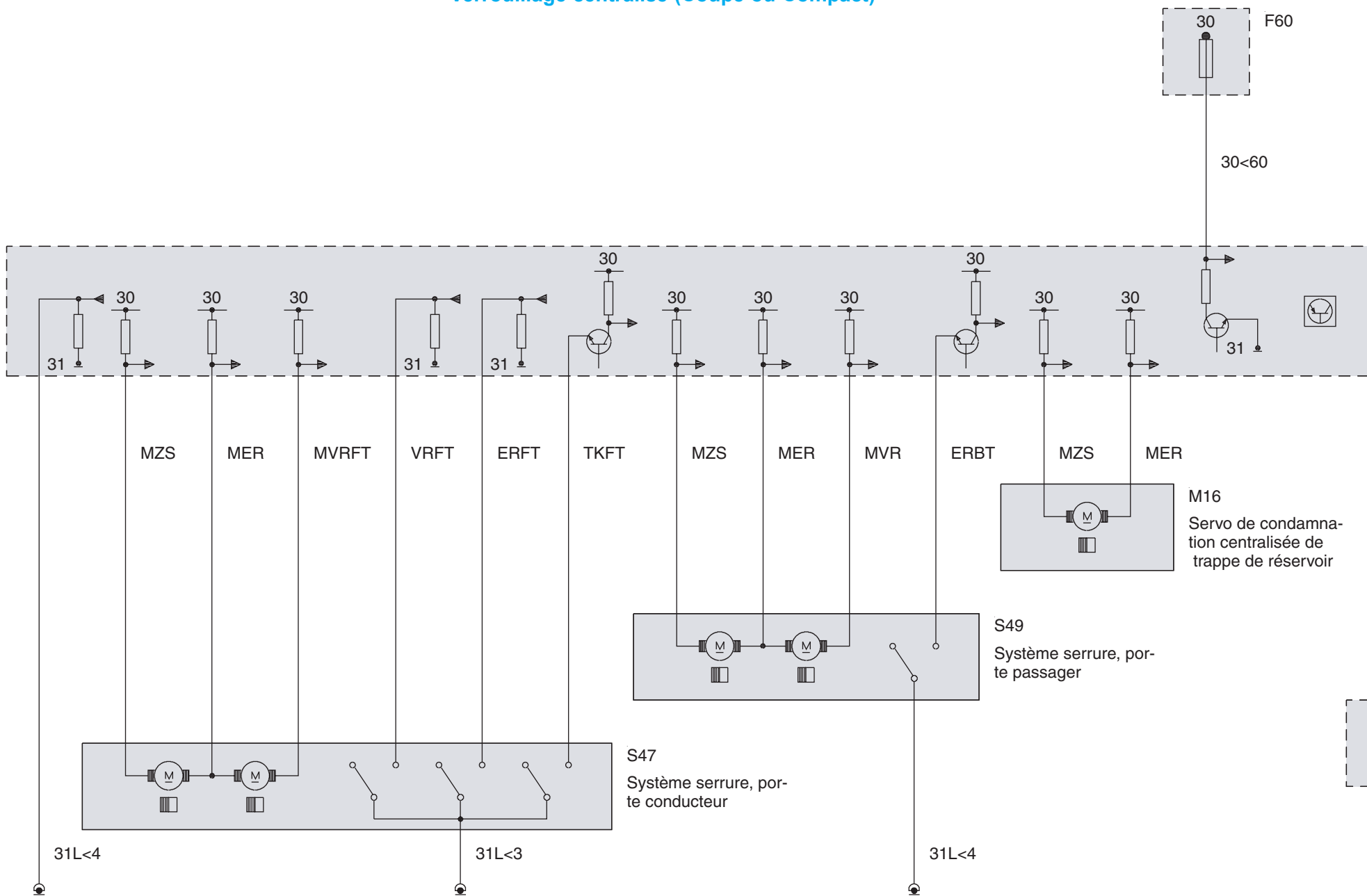





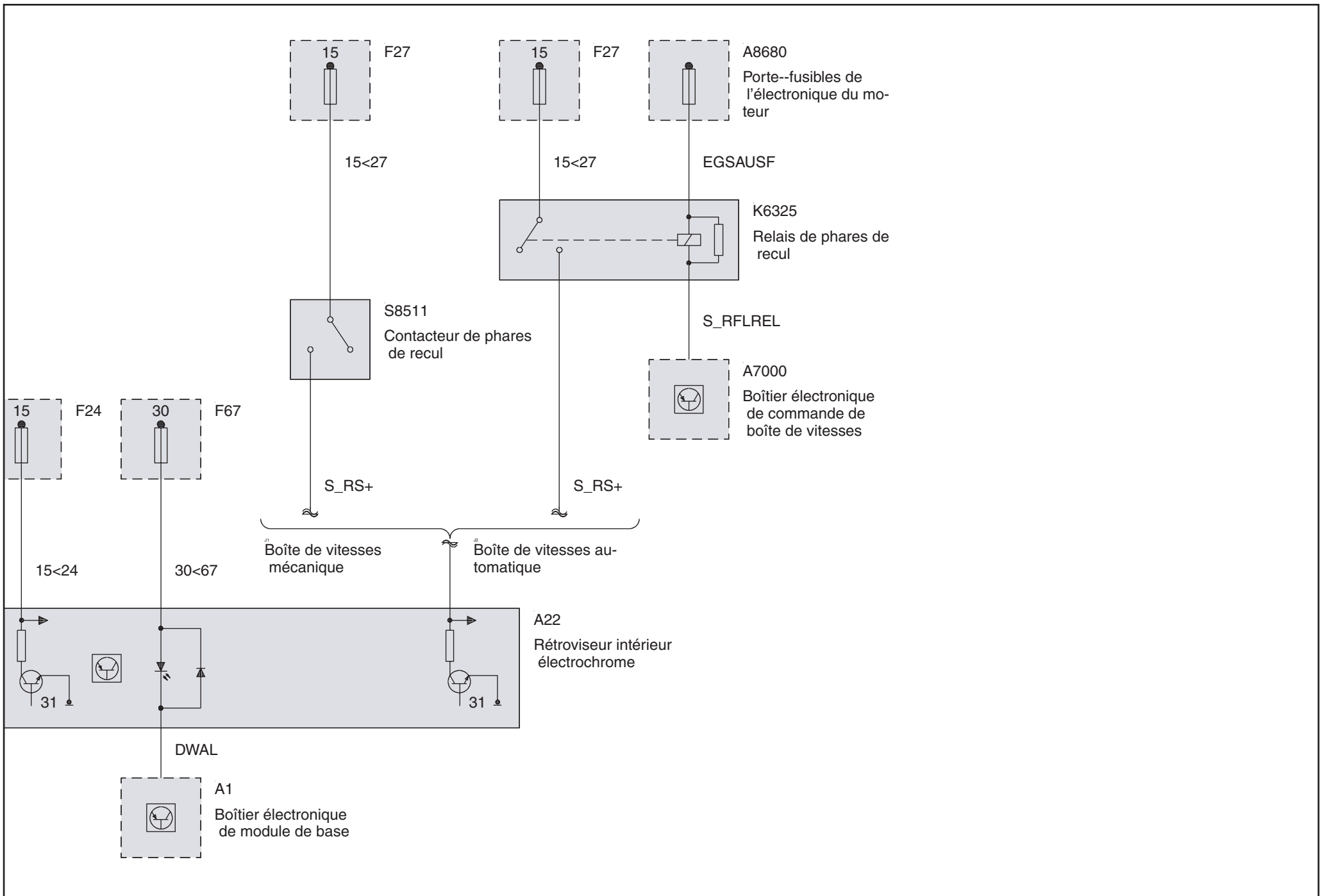

Alimentation

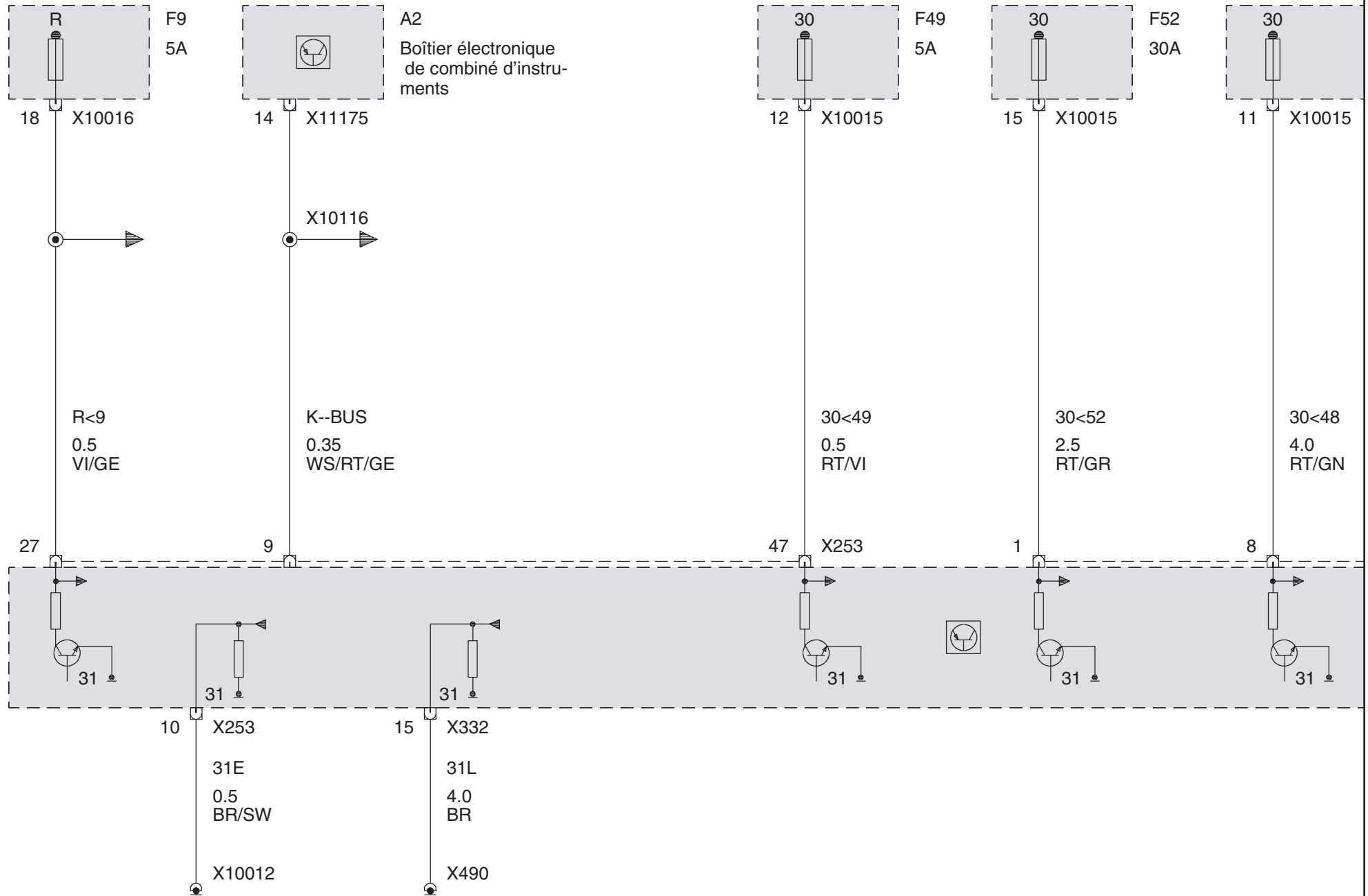

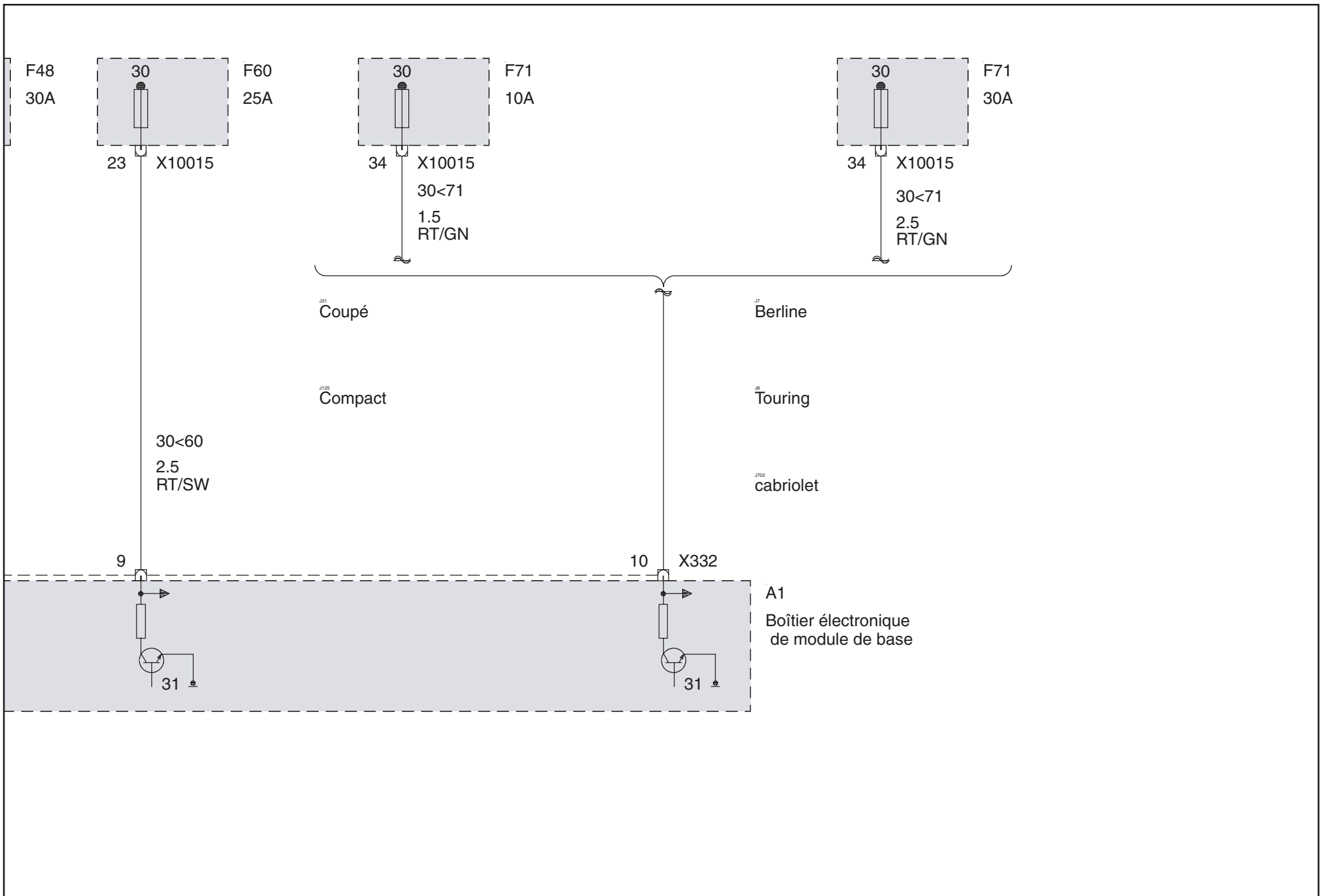

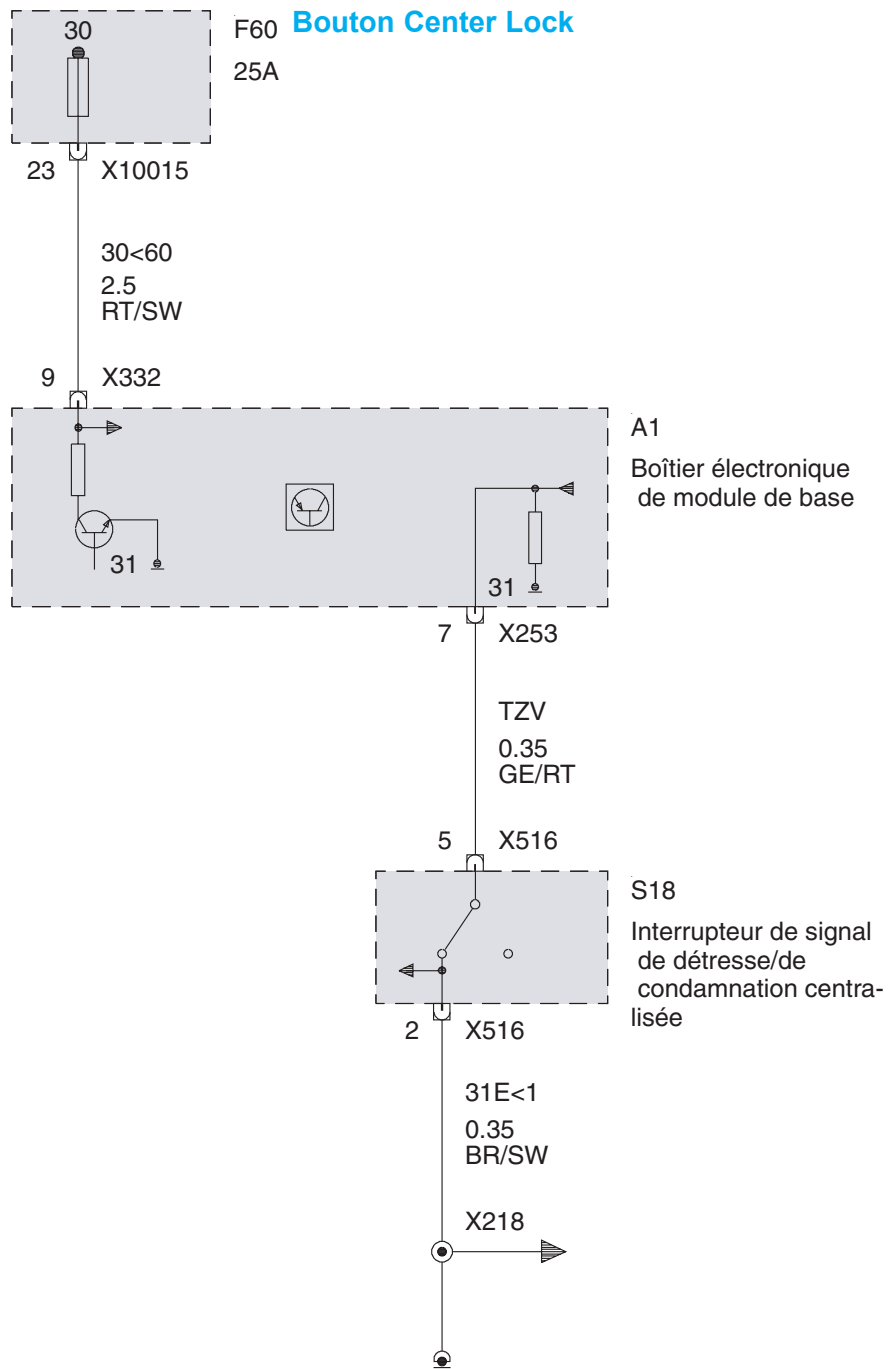



Système serrure, porte passager

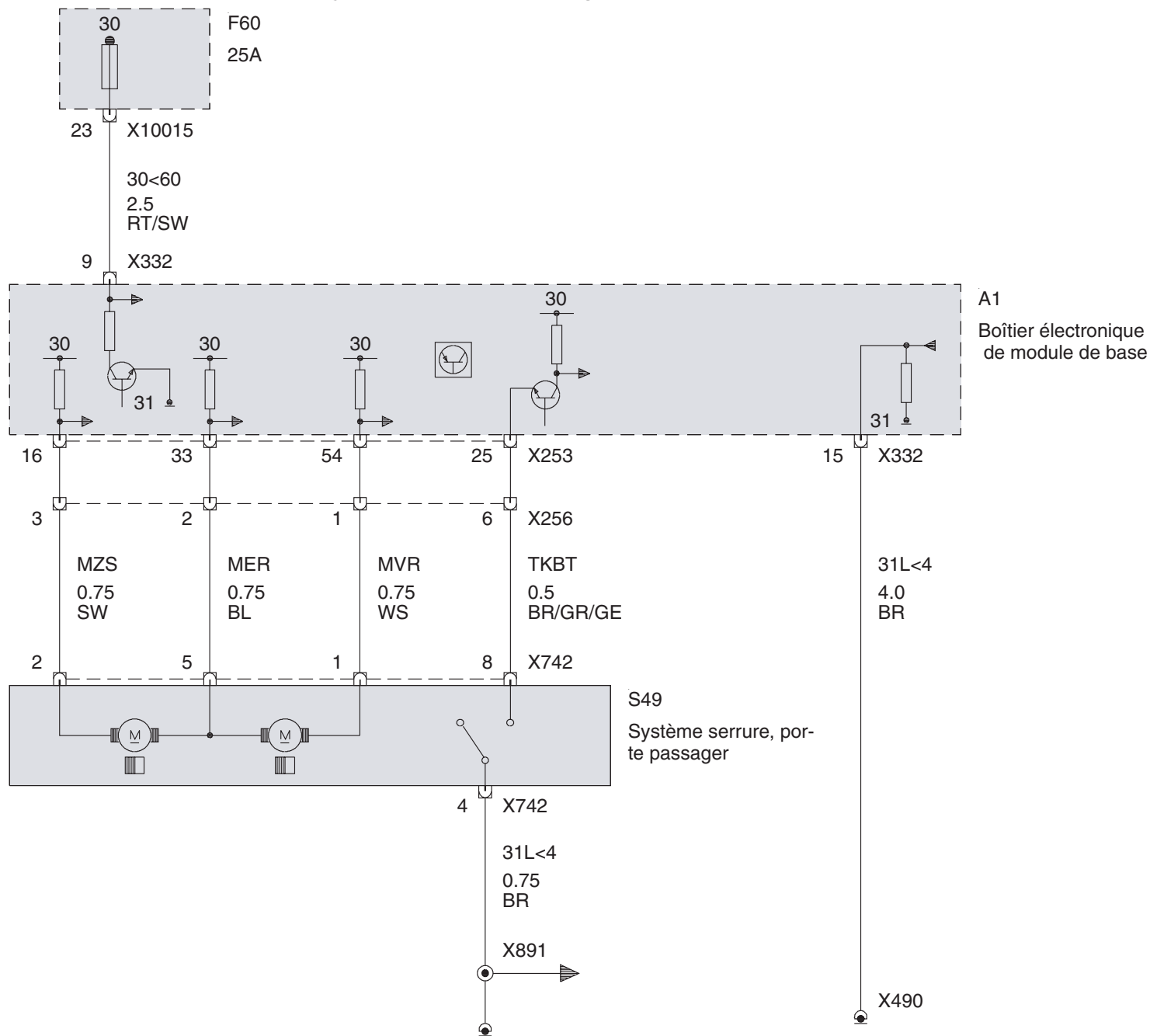

Actionneur porte ArG

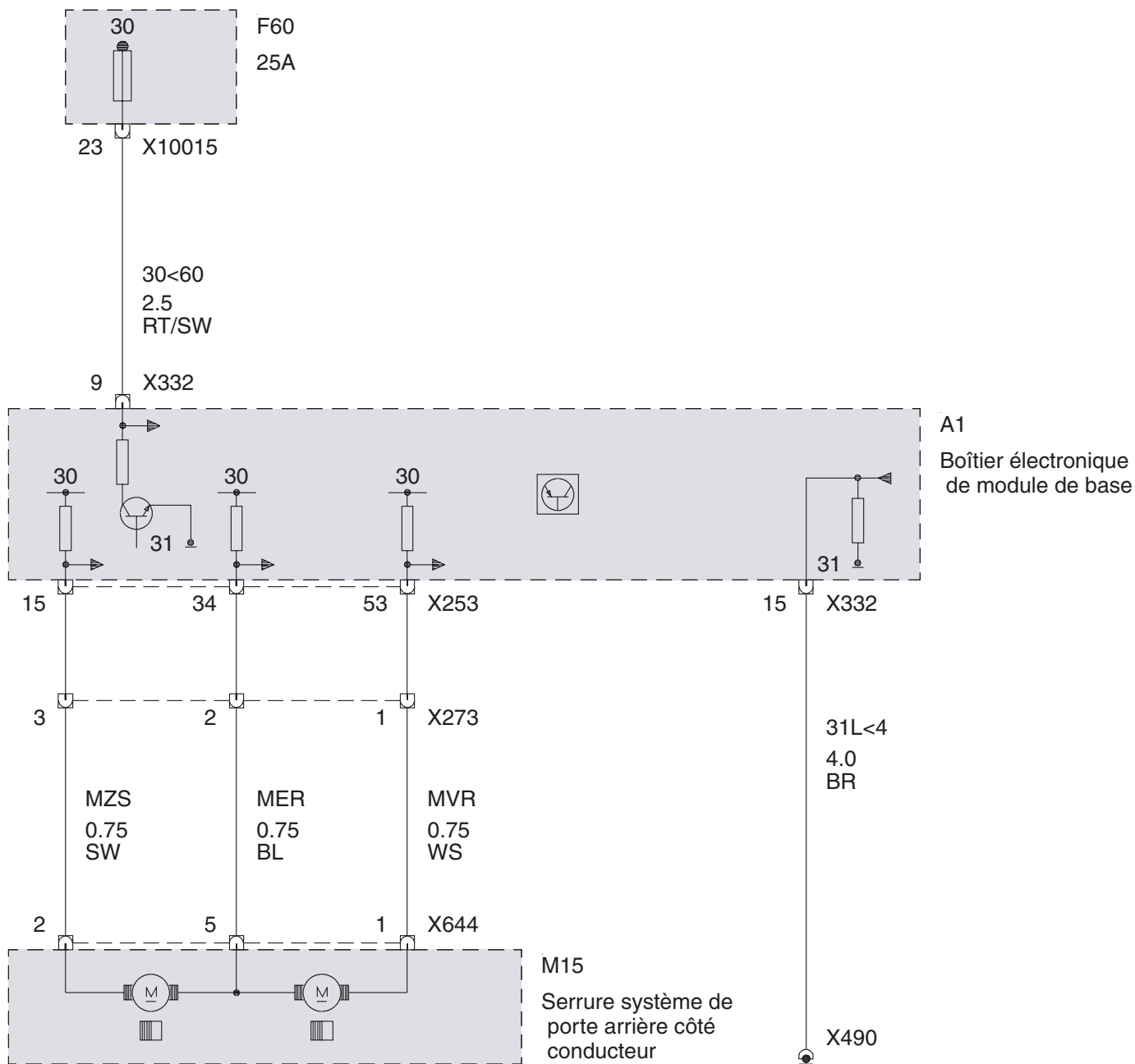

Actionneur porte ArD

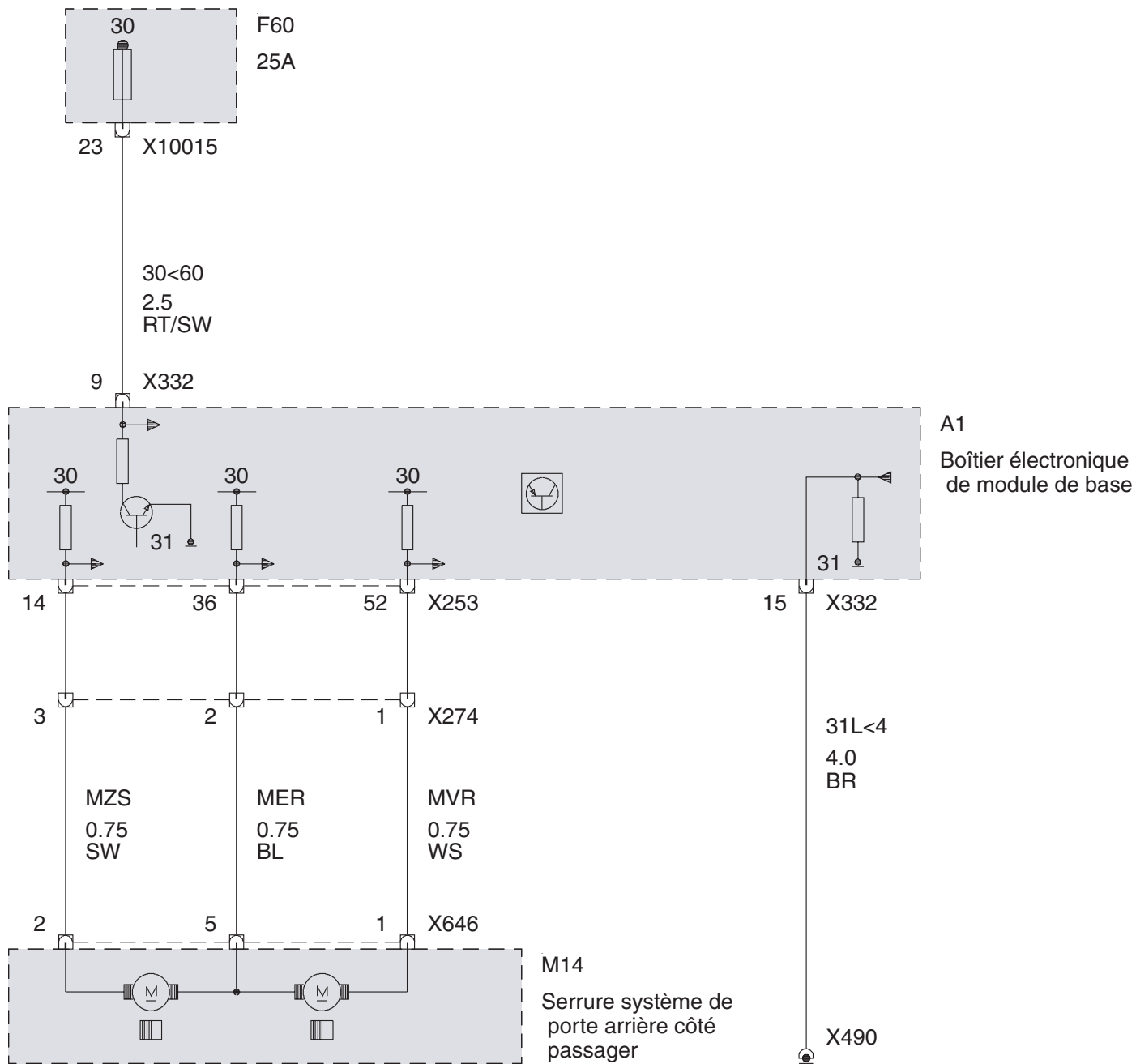



Actionneur trappe de réservoir (jusque 2003\_03)

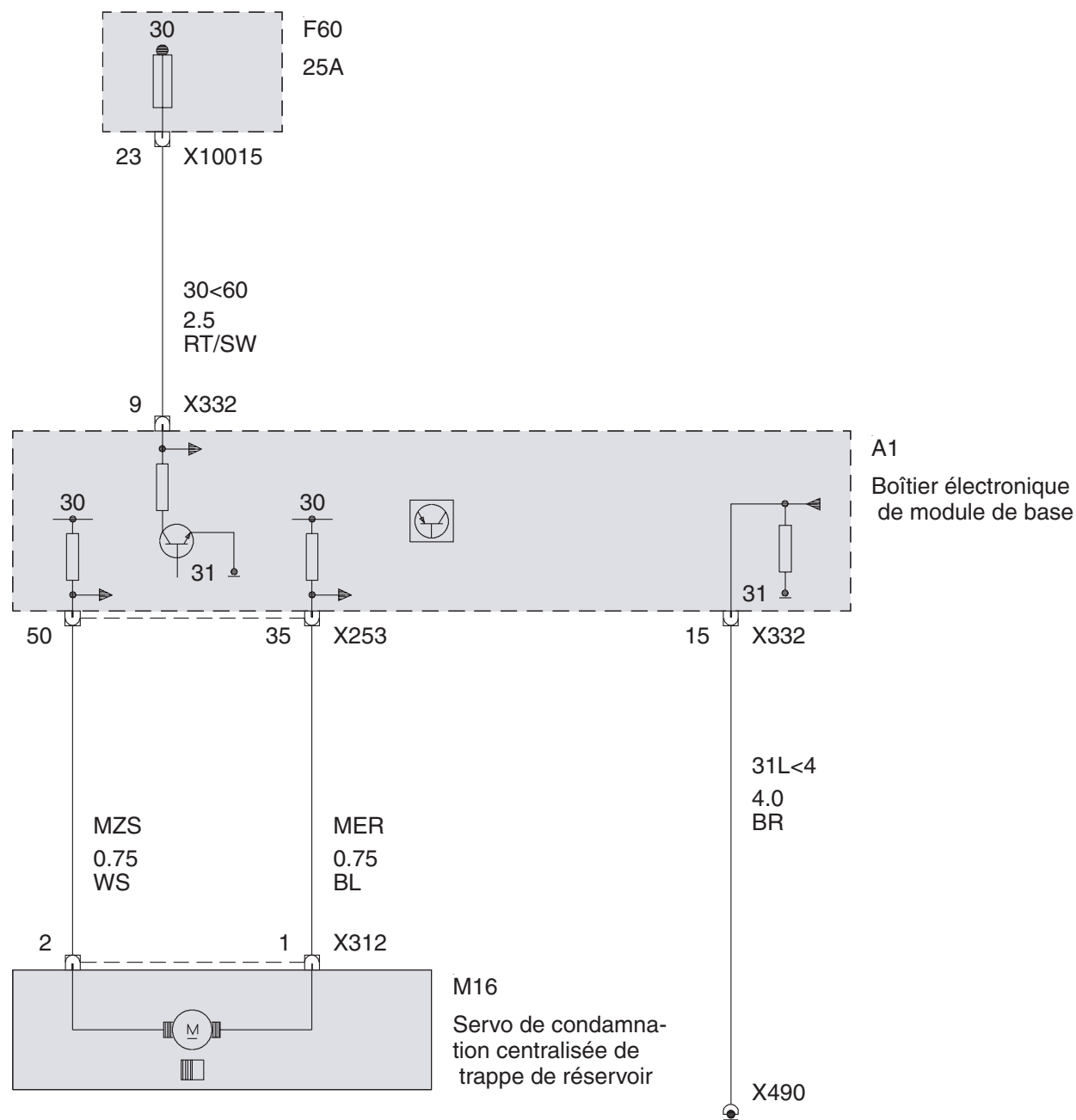

Actionneur trappe de réservoir (à partir de 2003\_03)

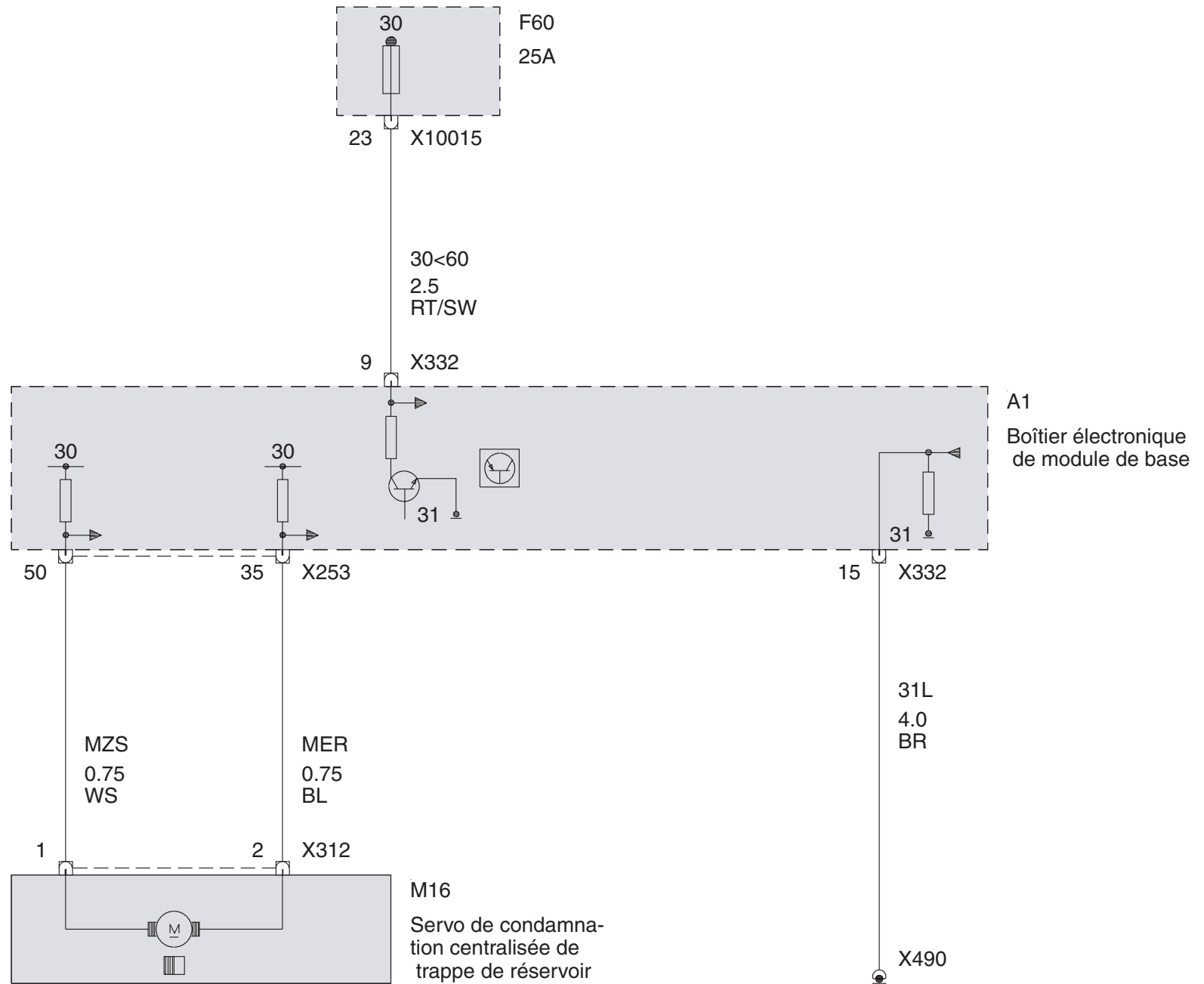

Détection de choc/crash

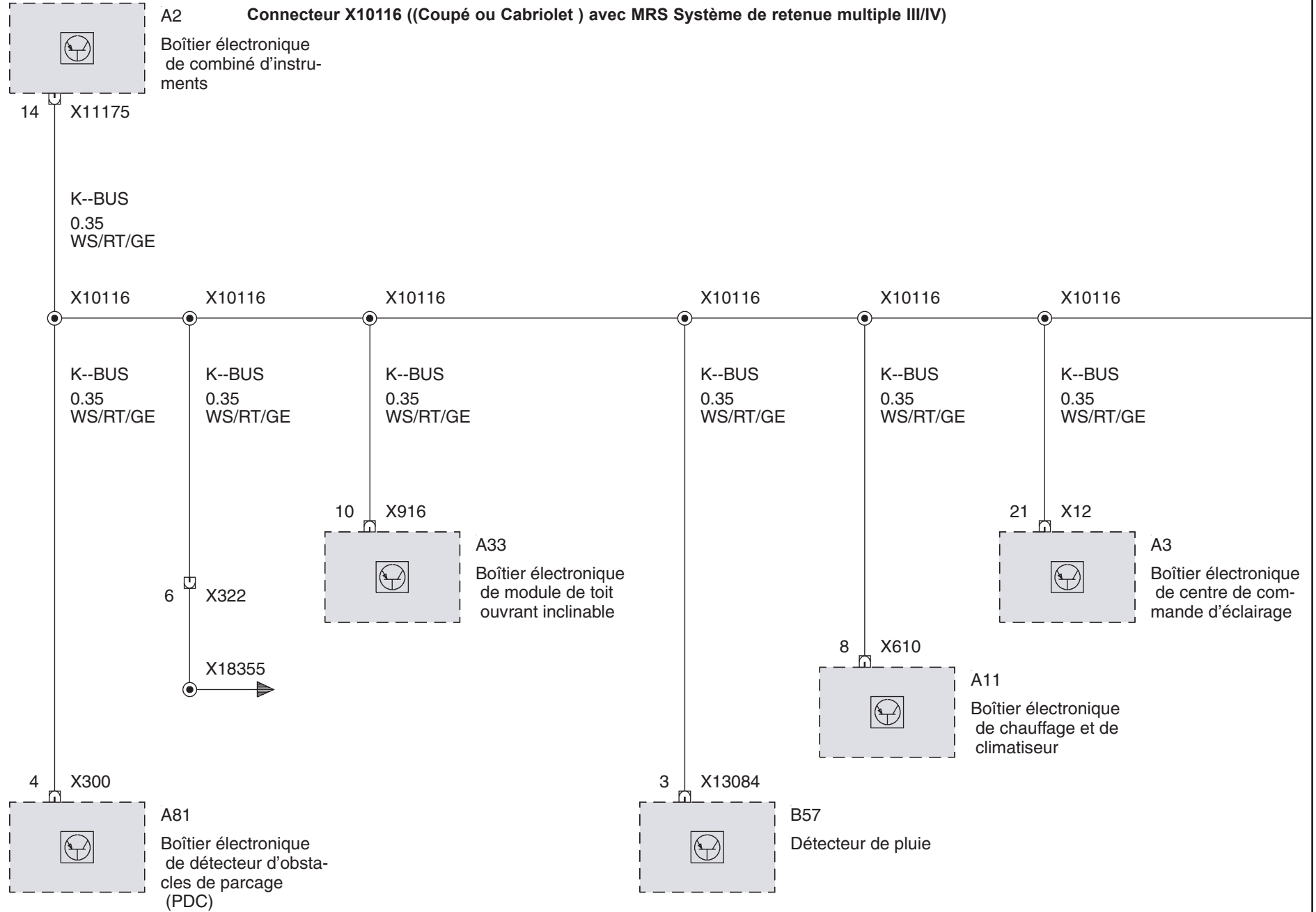

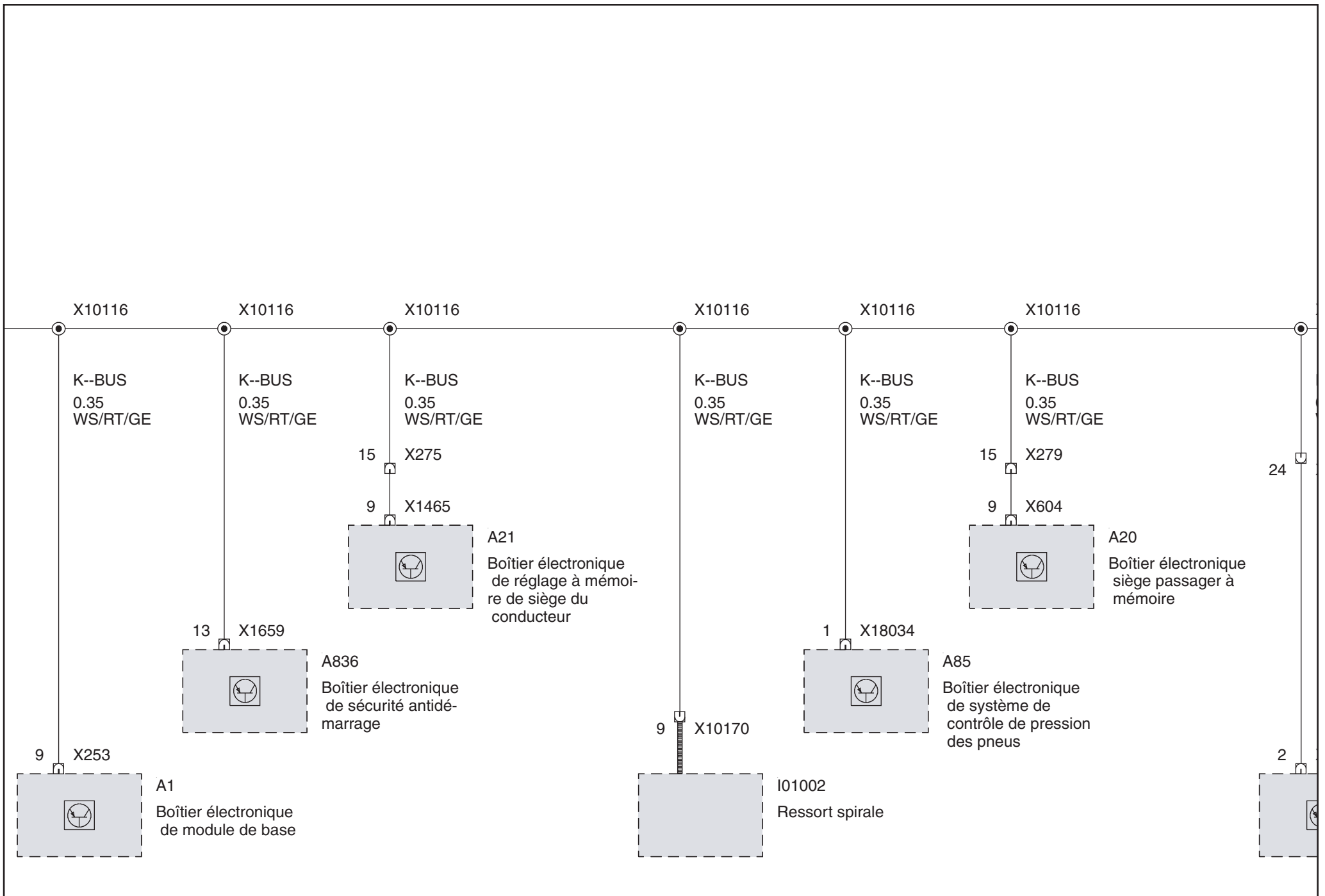

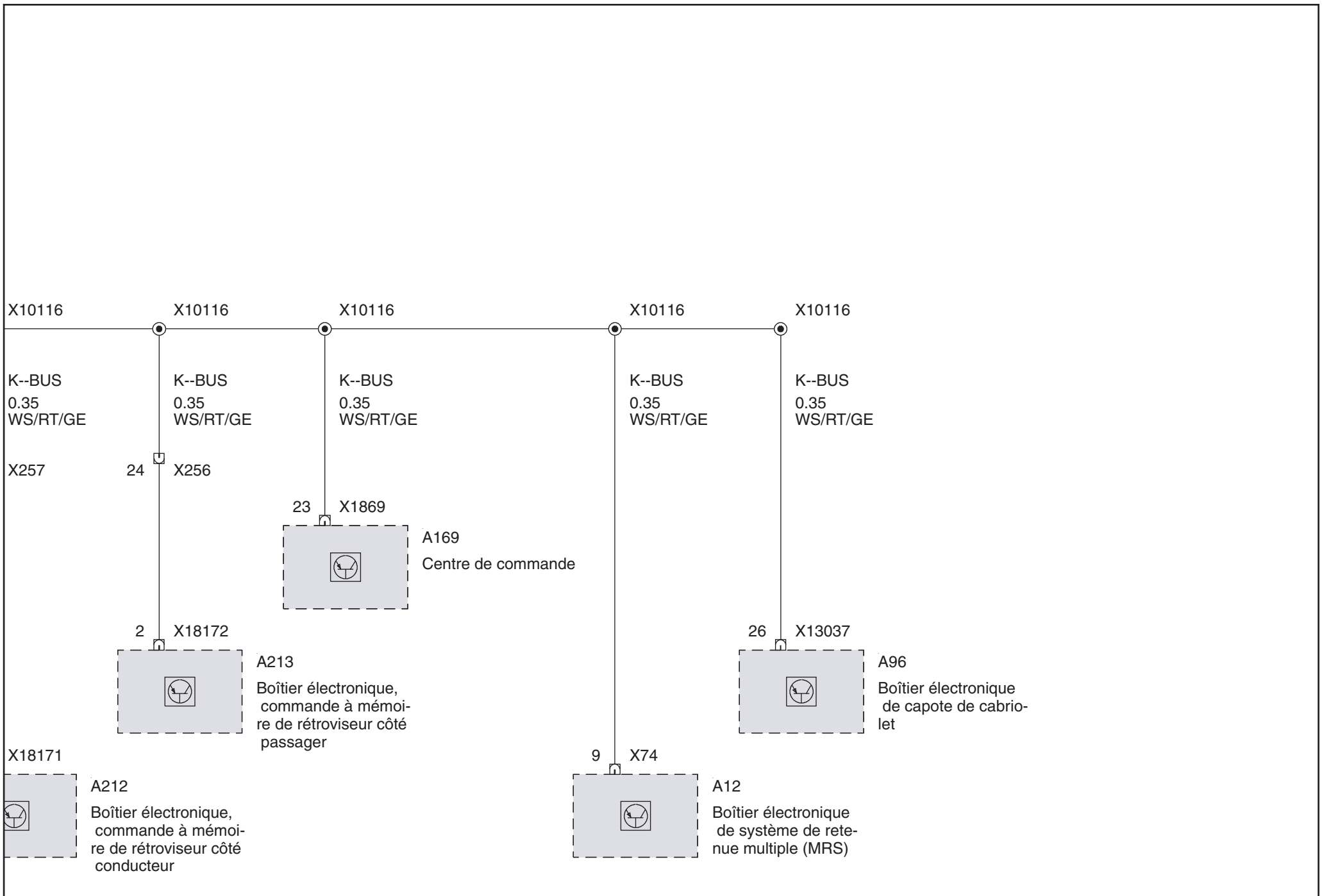

Connecteur X10116 (( Berline ou Touring ou Compact ) avec MRS Système de retenue multiple III/IV)

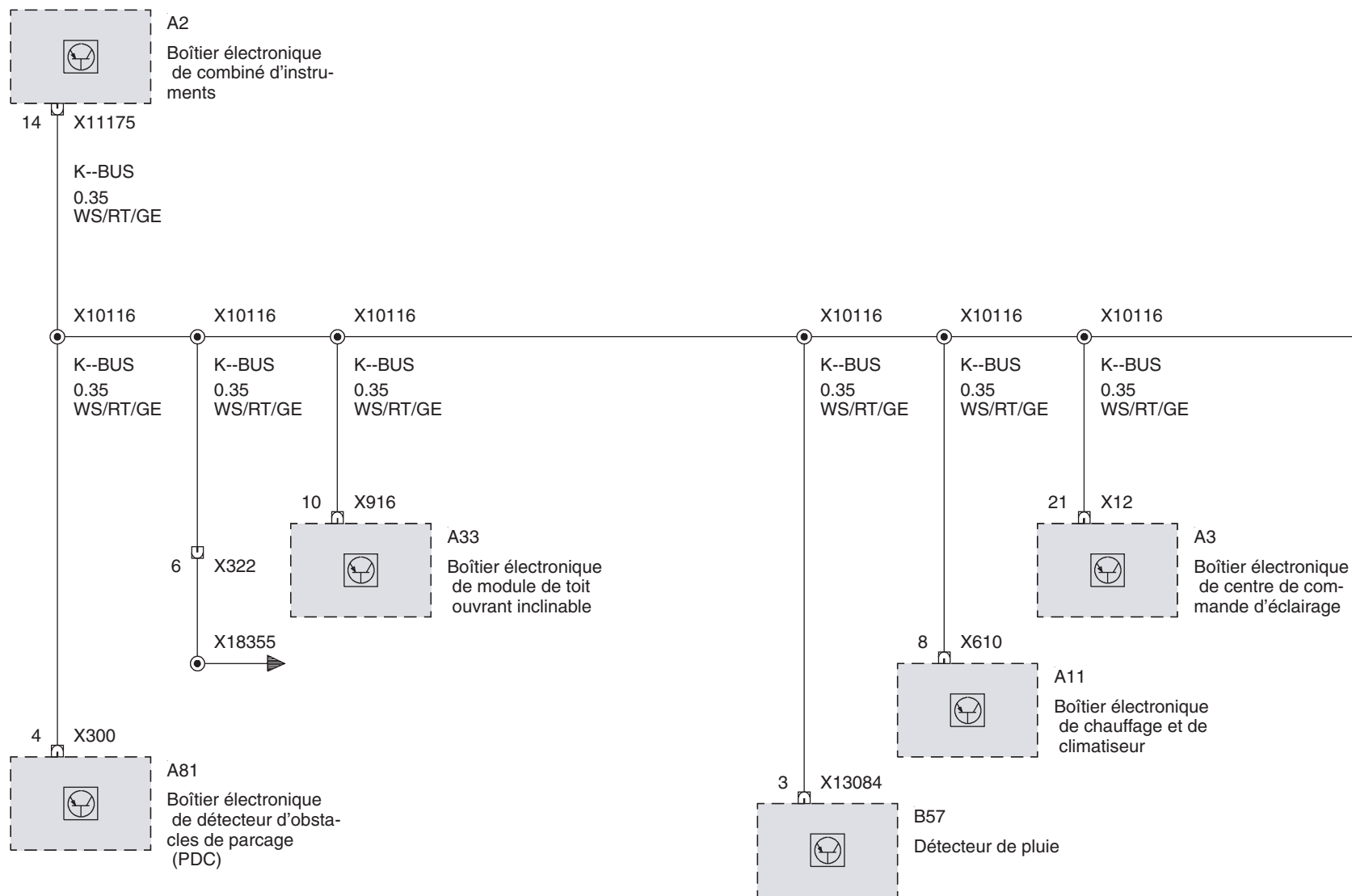

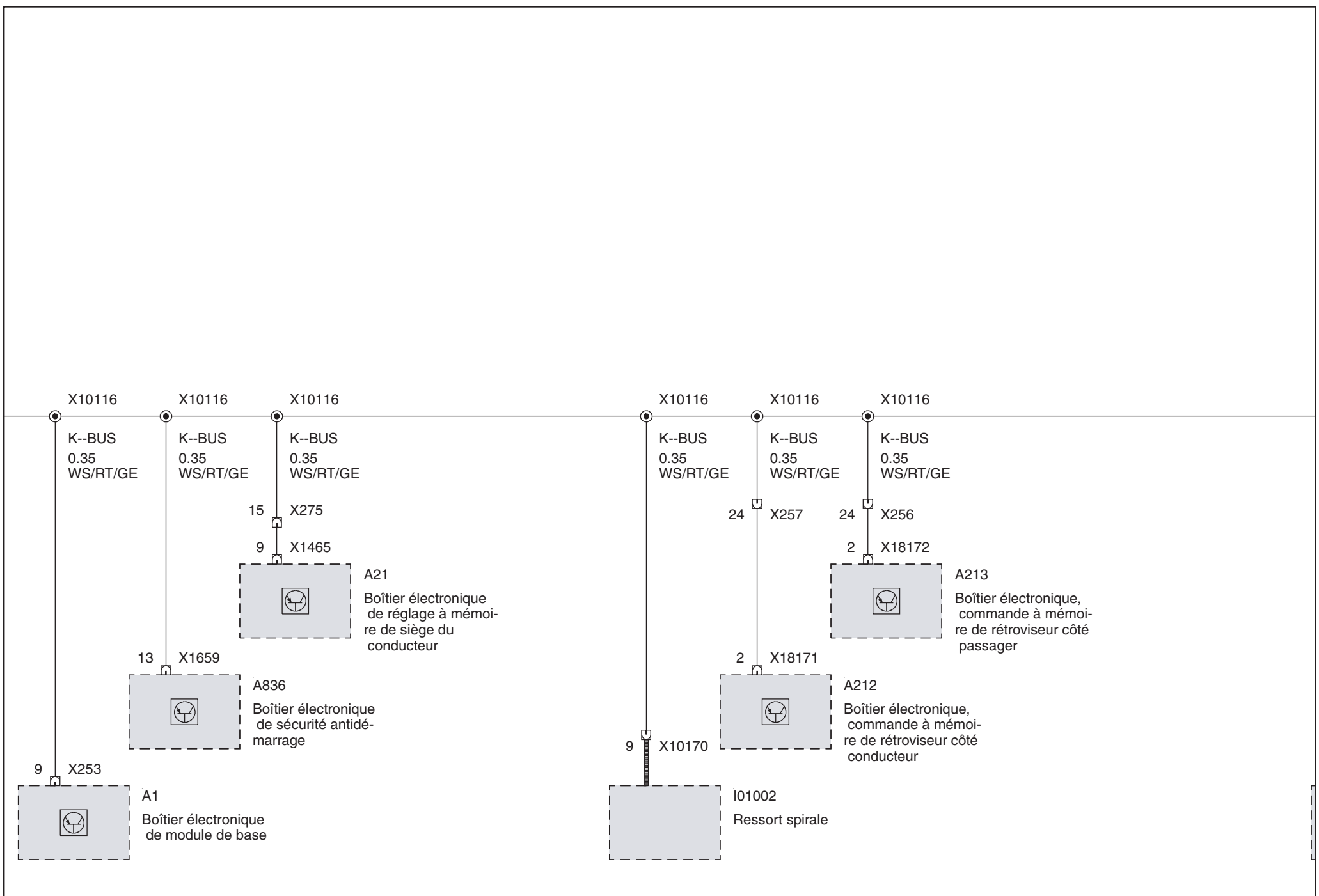

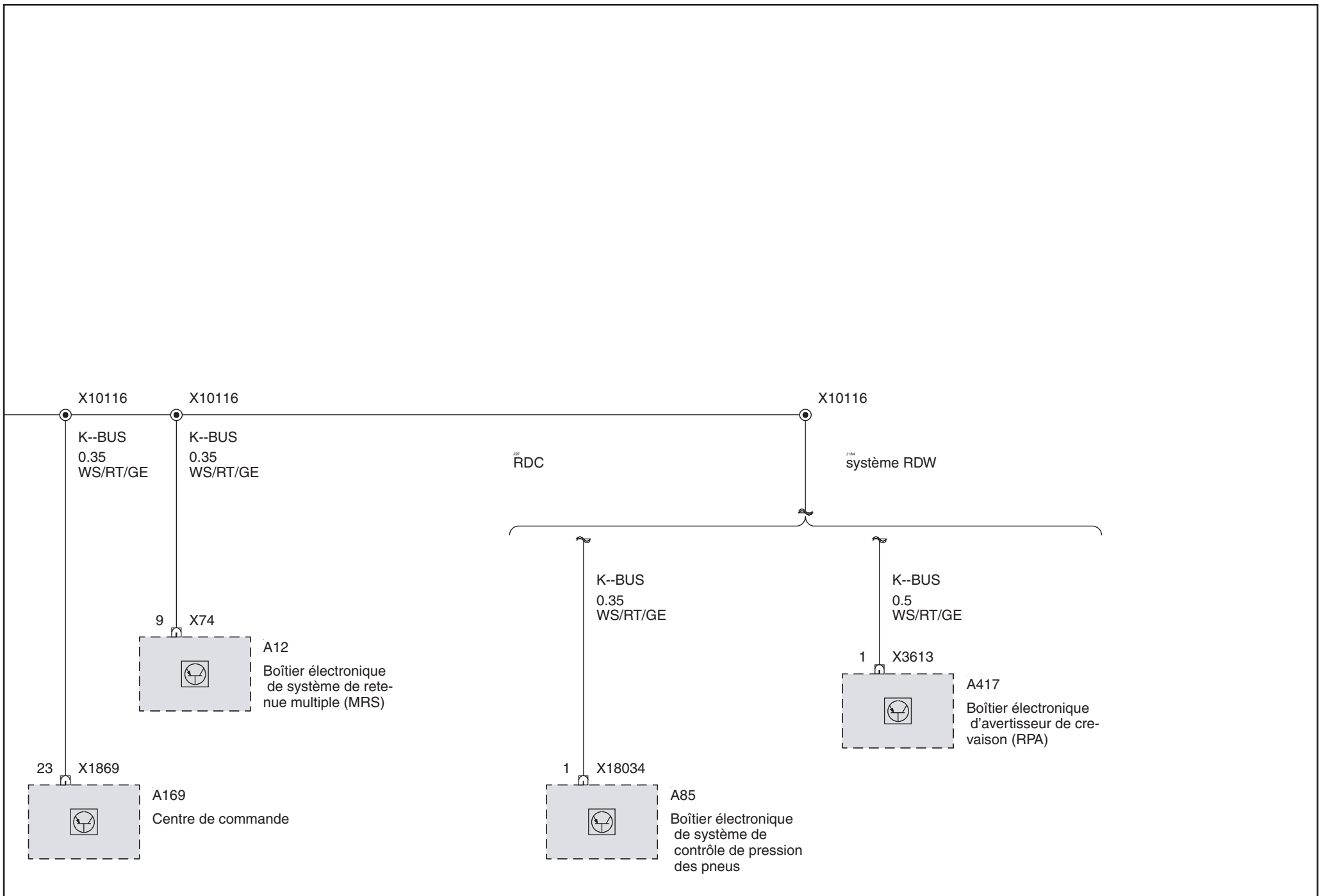



Télécommande et radiocommande

Radiocommande (sauf Touring ou Compact)

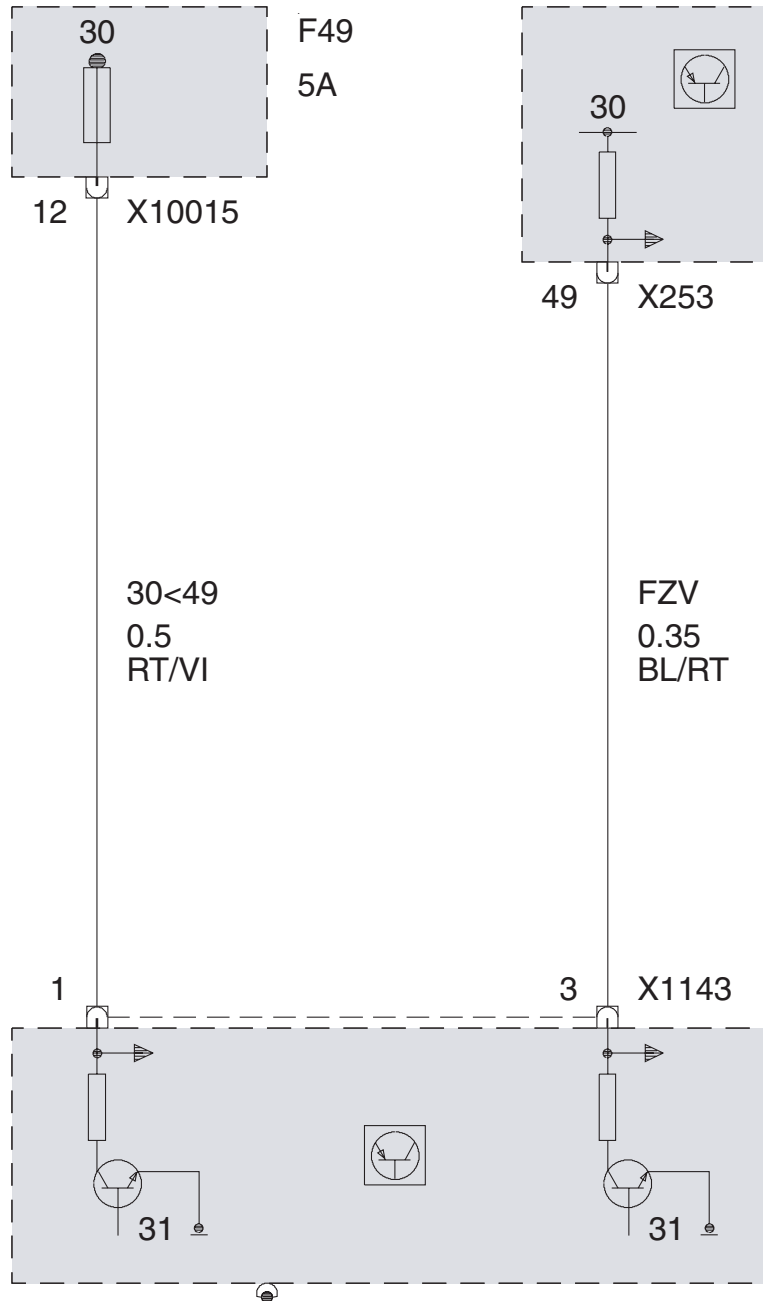

F49  
5A

A1  
Boîtier électronique  
de module de base

30<49  
0.5  
RT/VI

FZV  
0.35  
BL/RT

N8  
Ampli d'antenne AM/  
FM  
1) avec télécomman-  
de de verrouillage  
centralisé

Radiocommande (Touring ou Compact)

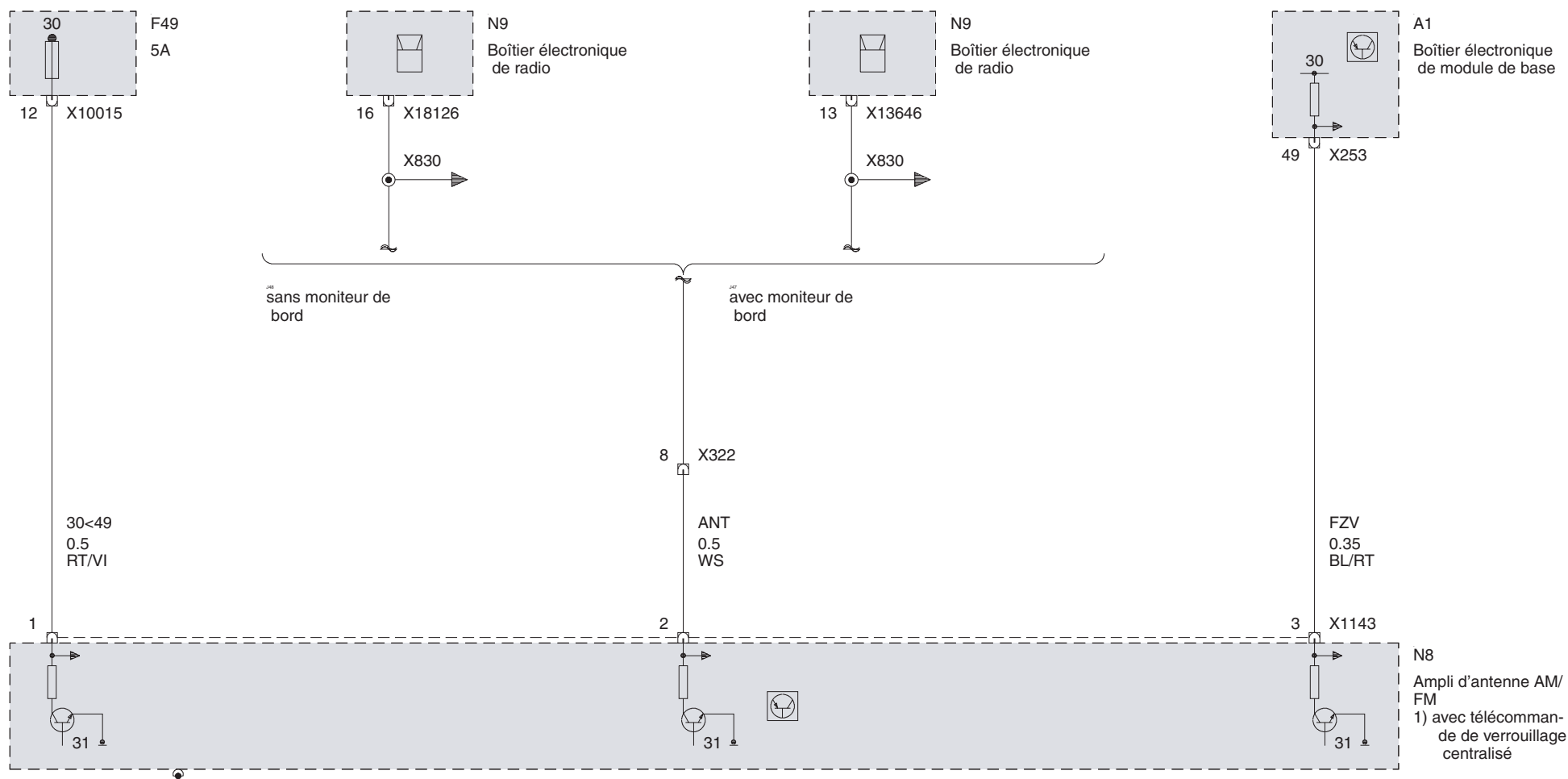

Télécommande à infrarouge (Essence sans Boîte automatique)

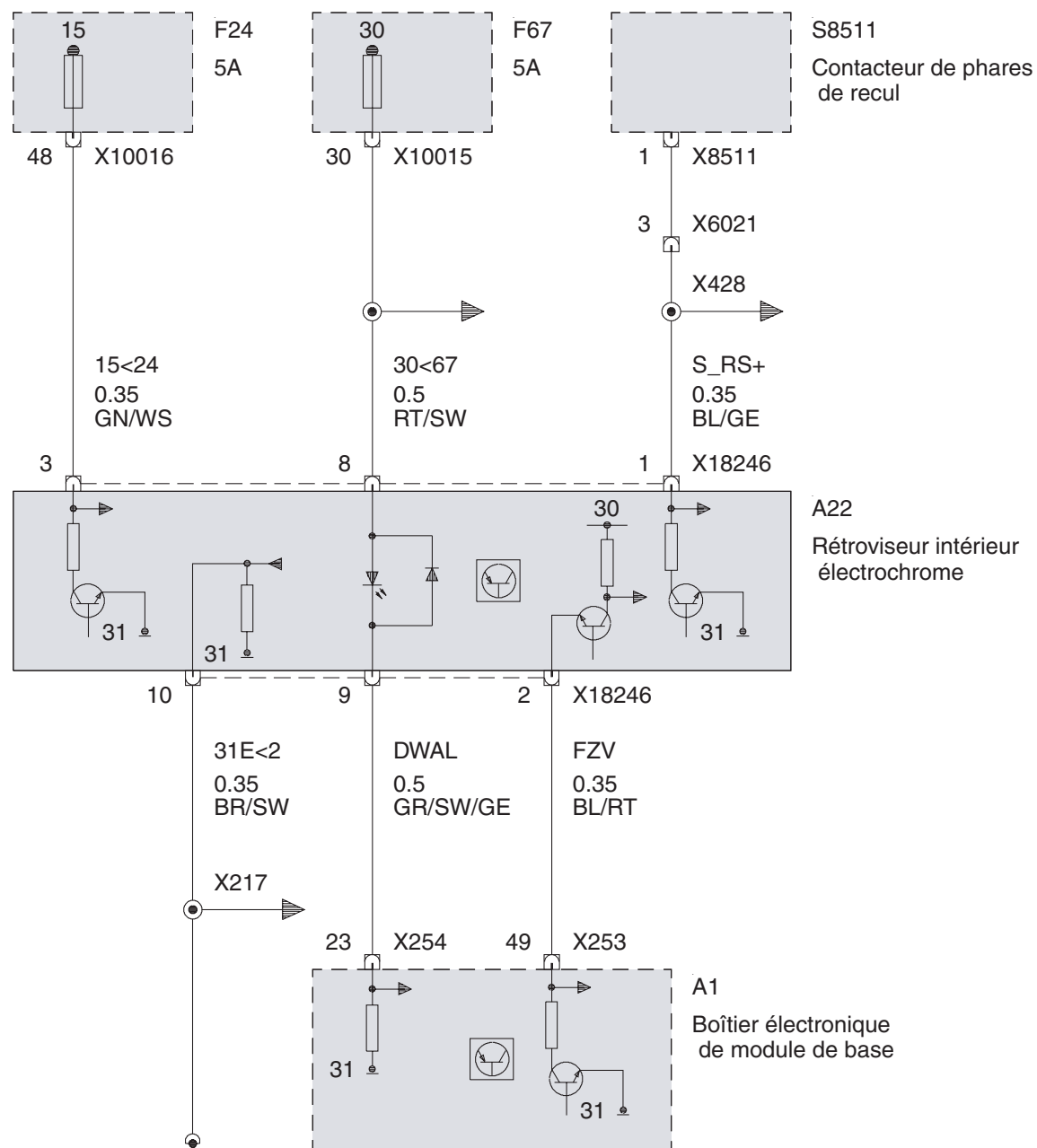

Télécommande à infrarouge (Essence avec Boîte automatique)

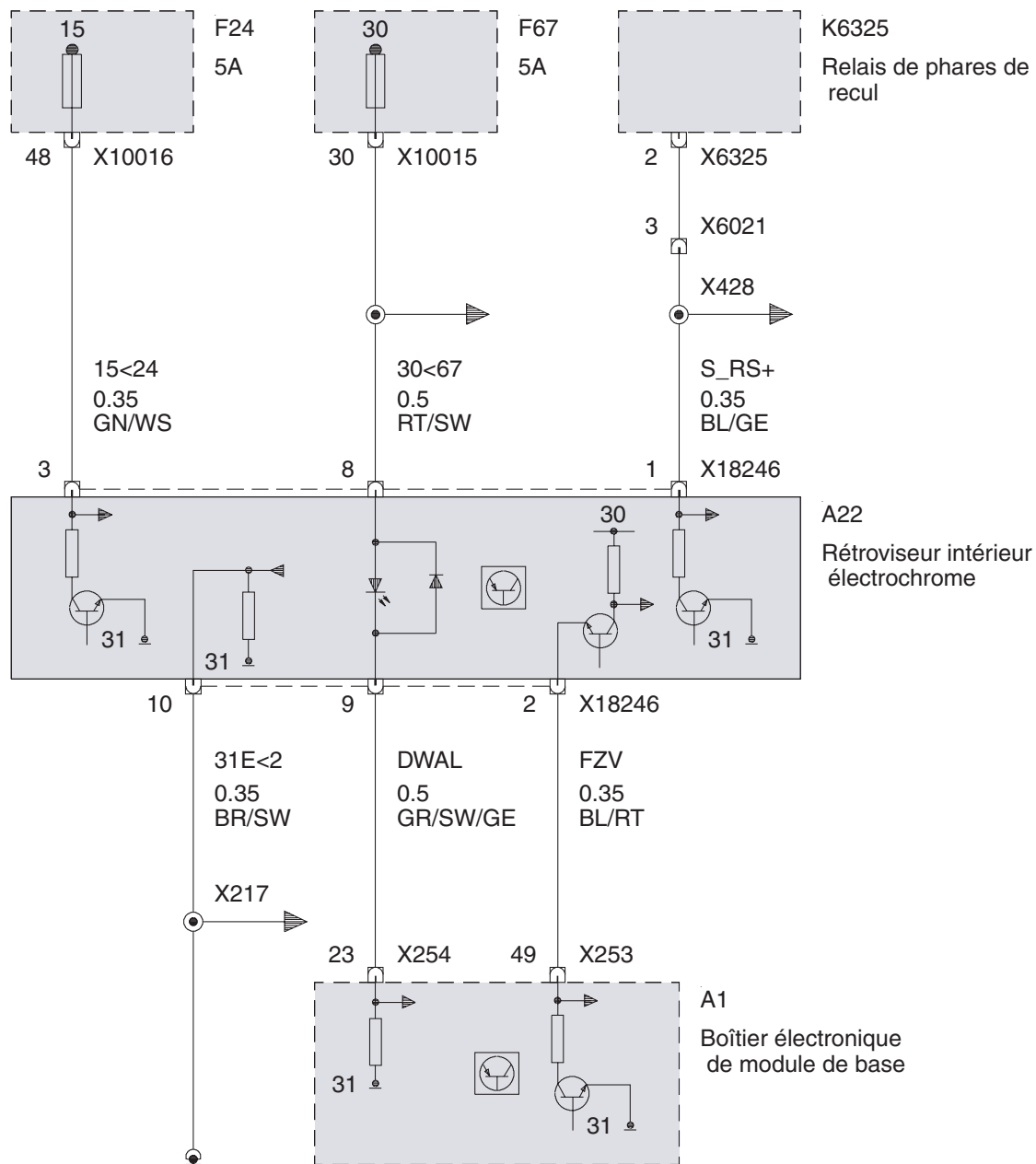

Télécommande à infrarouge (Diesel)

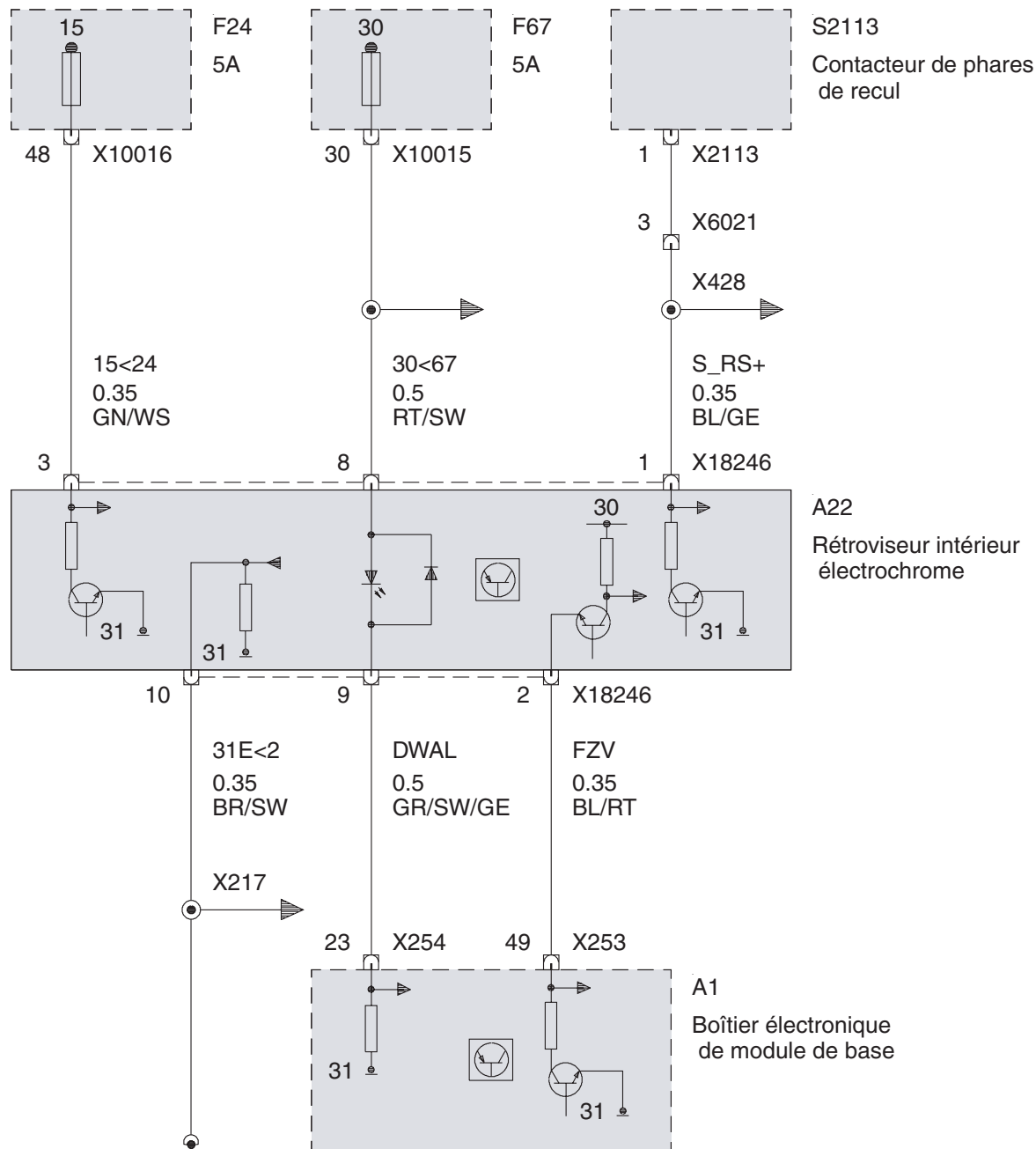

## Hayon/lunette AR

Touche de capot arrière, dans l'habitacle

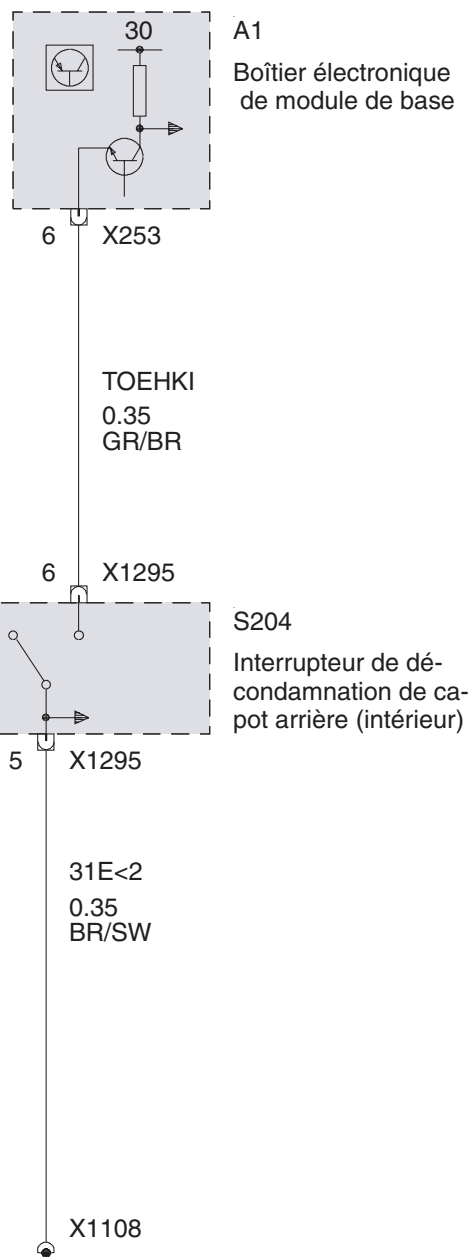

Poussoir capot AR

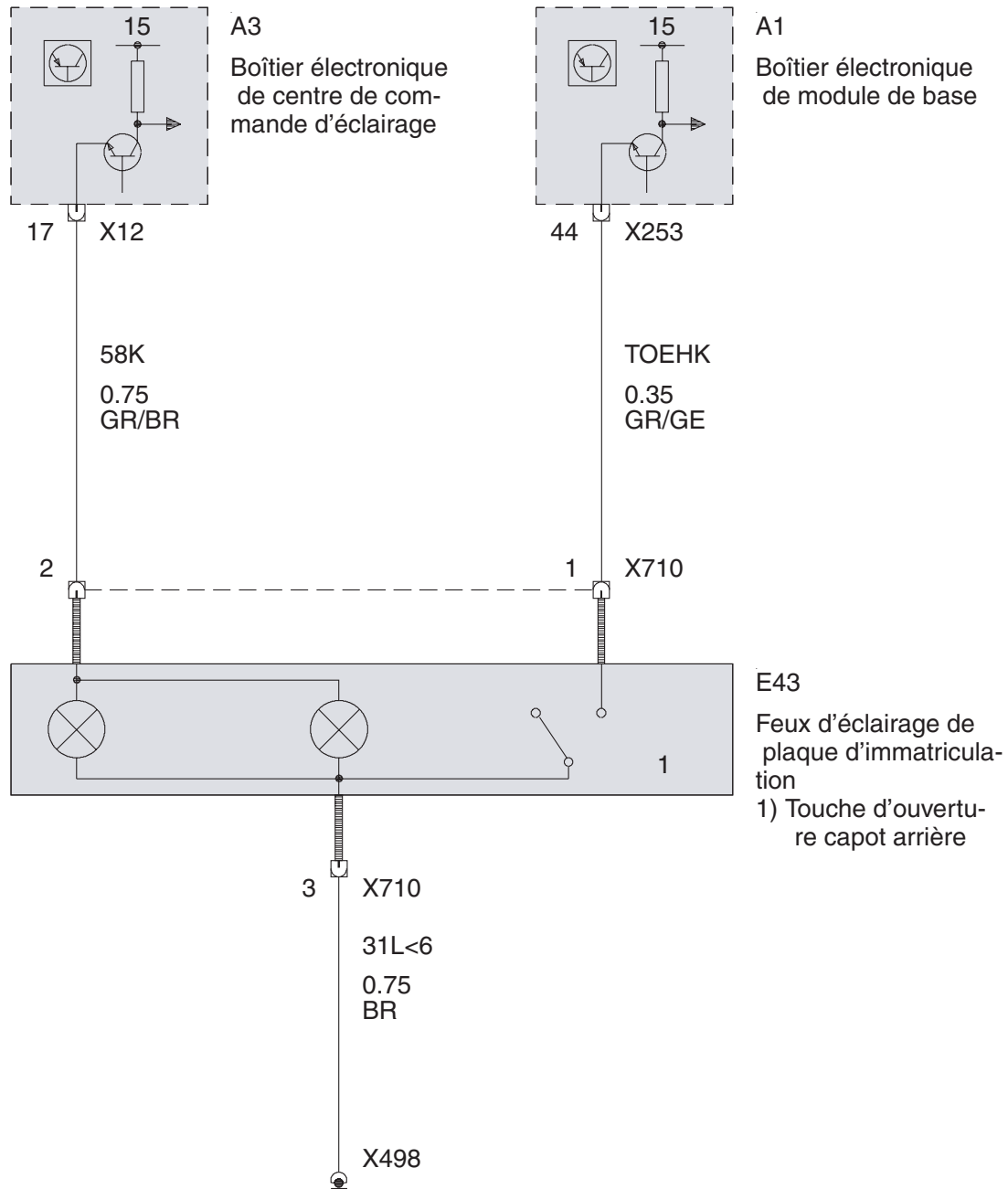

Déverrouillage de capot arrière (Berline ou Coupé)

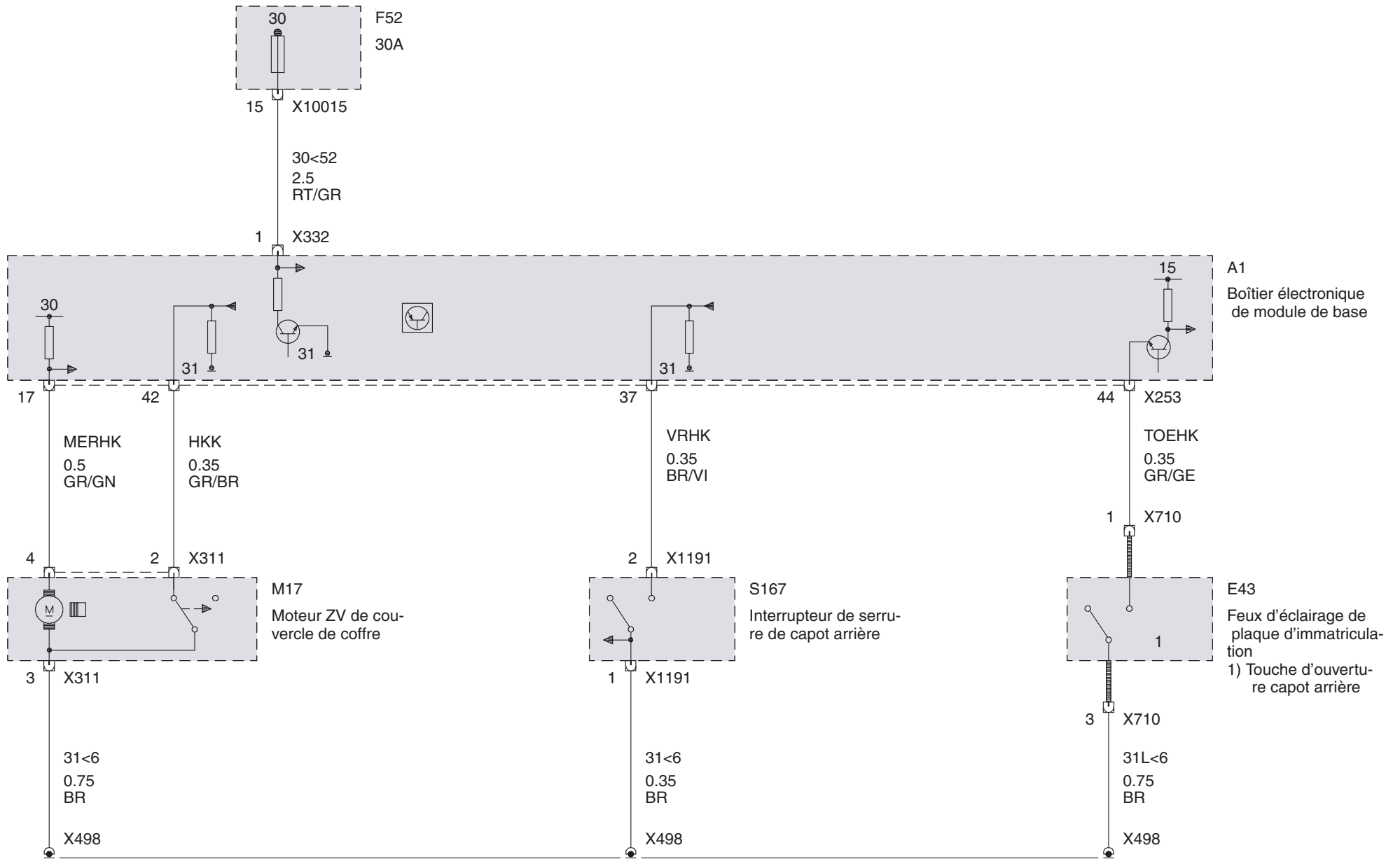



Déverrouillage de capot arrière (Touring)

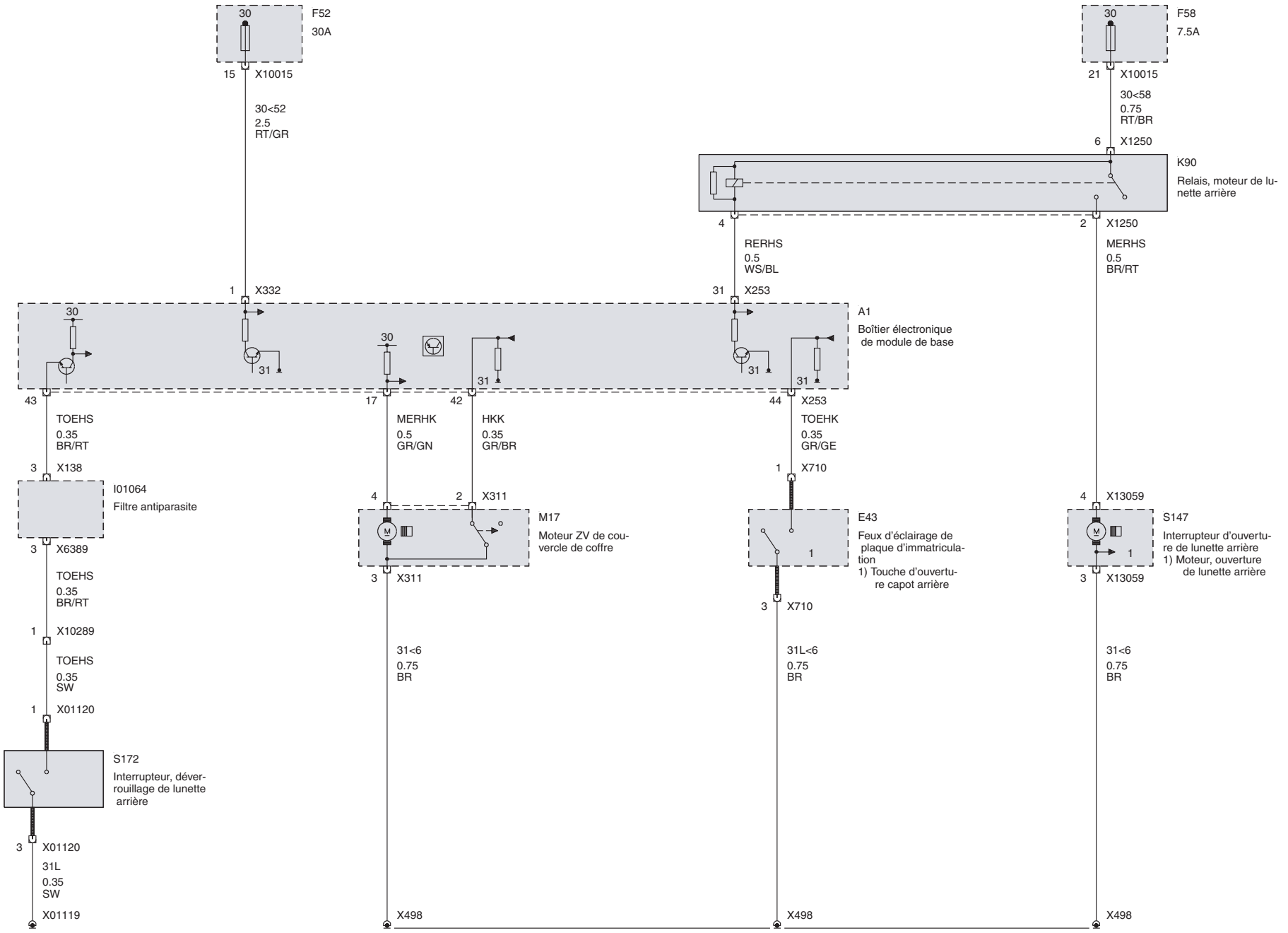

Déverrouillage de capot arrière (Compact)

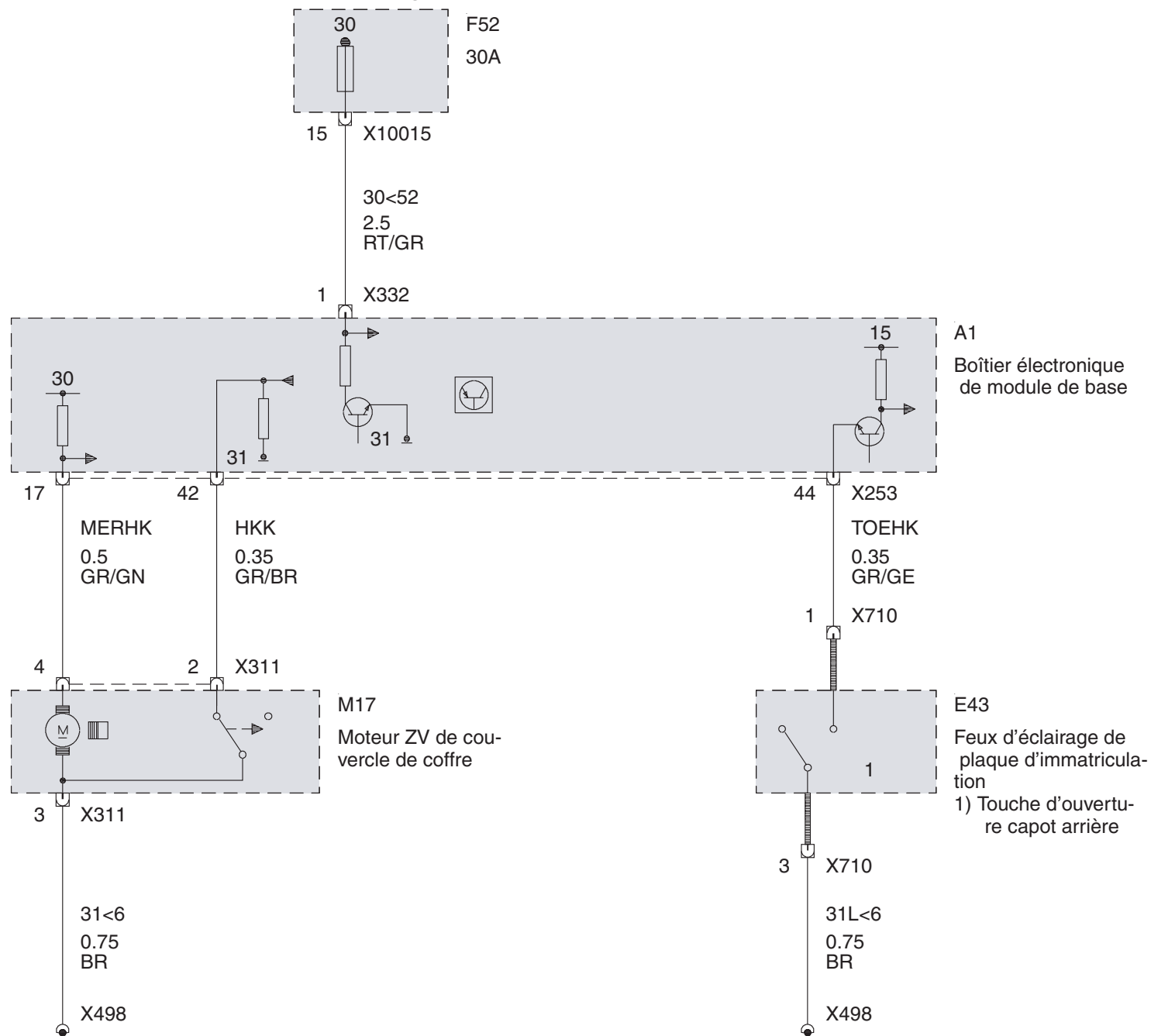

## Connecteur X10116

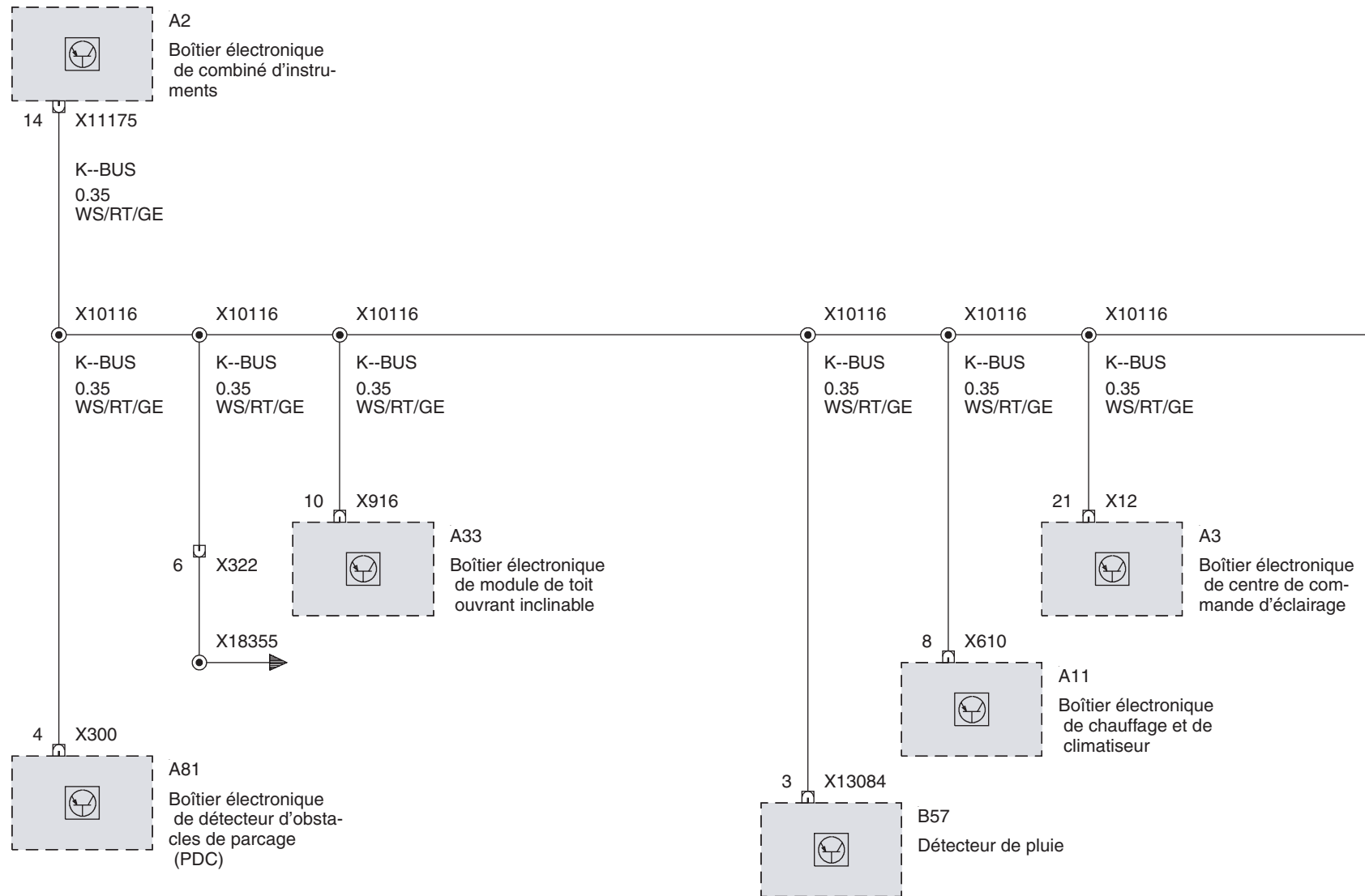

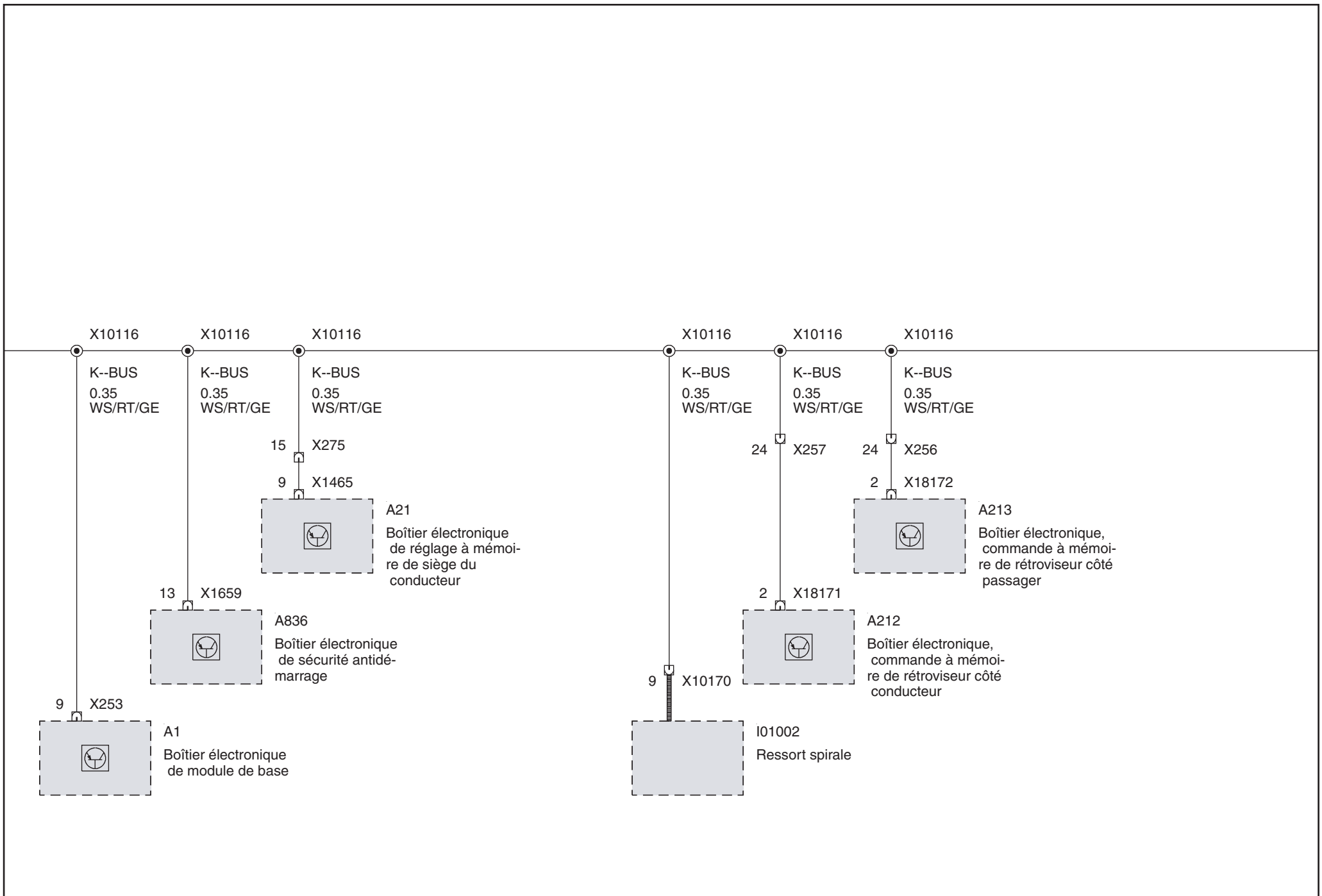

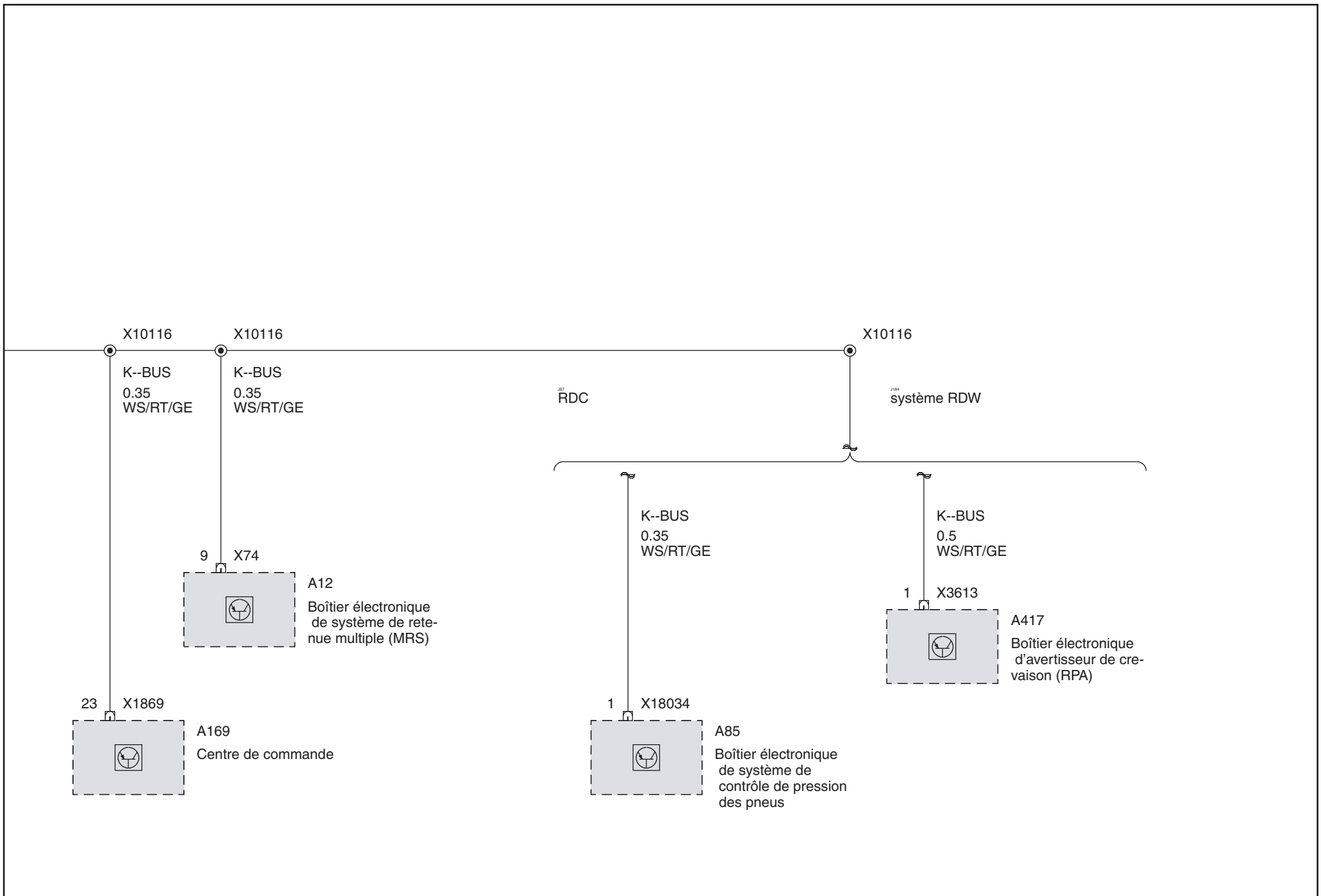

## Fonctions de signalisation acoustique

### Avertisseur sonore (jusque 2003\_03)

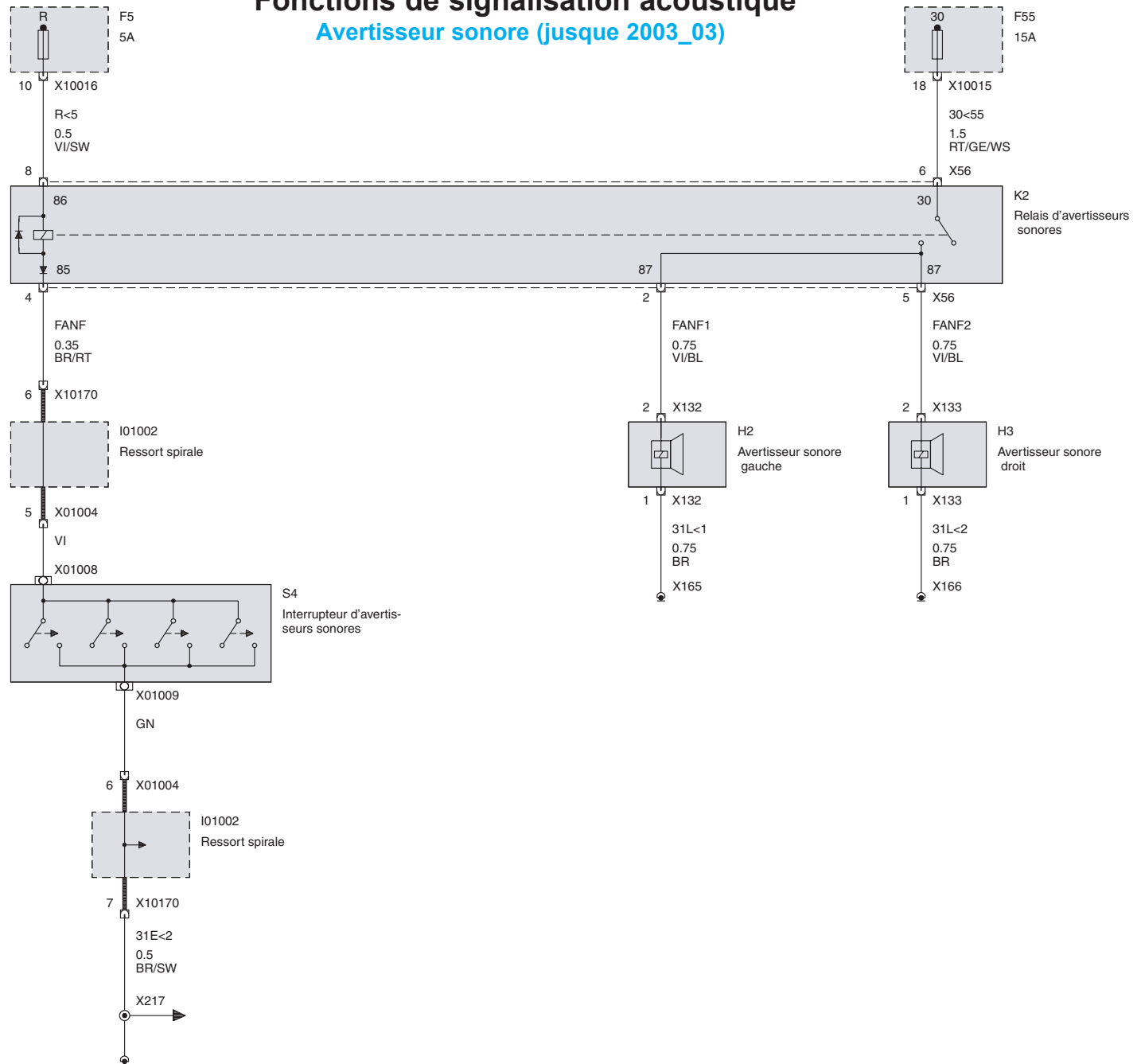

Avertisseur sonore (à partir de 2003\_03)

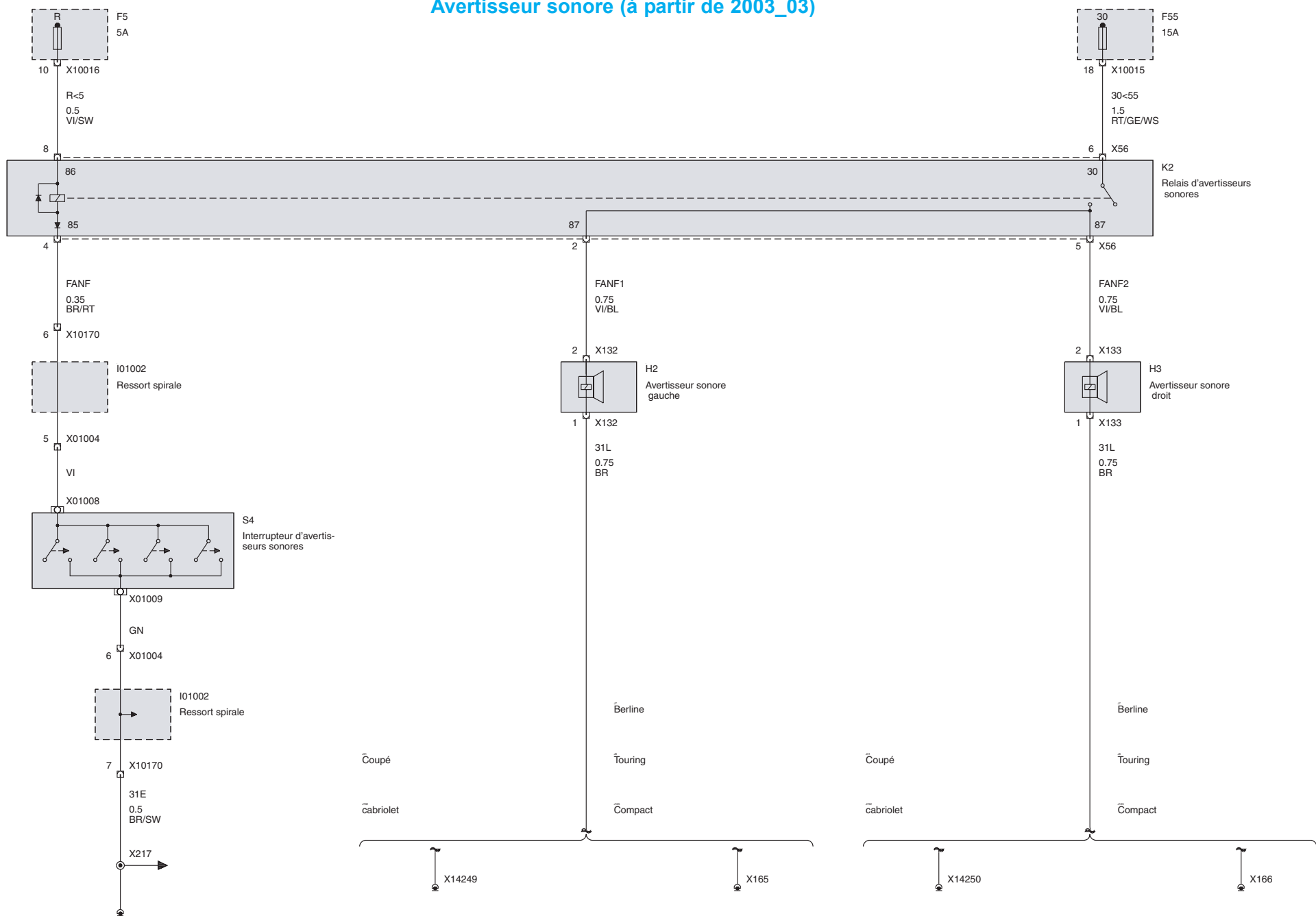

Détecteur d'obstacle de parcage (PDC)

Signalisation acoustique de distance (Essence sans Boîte automatique jusque 2003\_03)

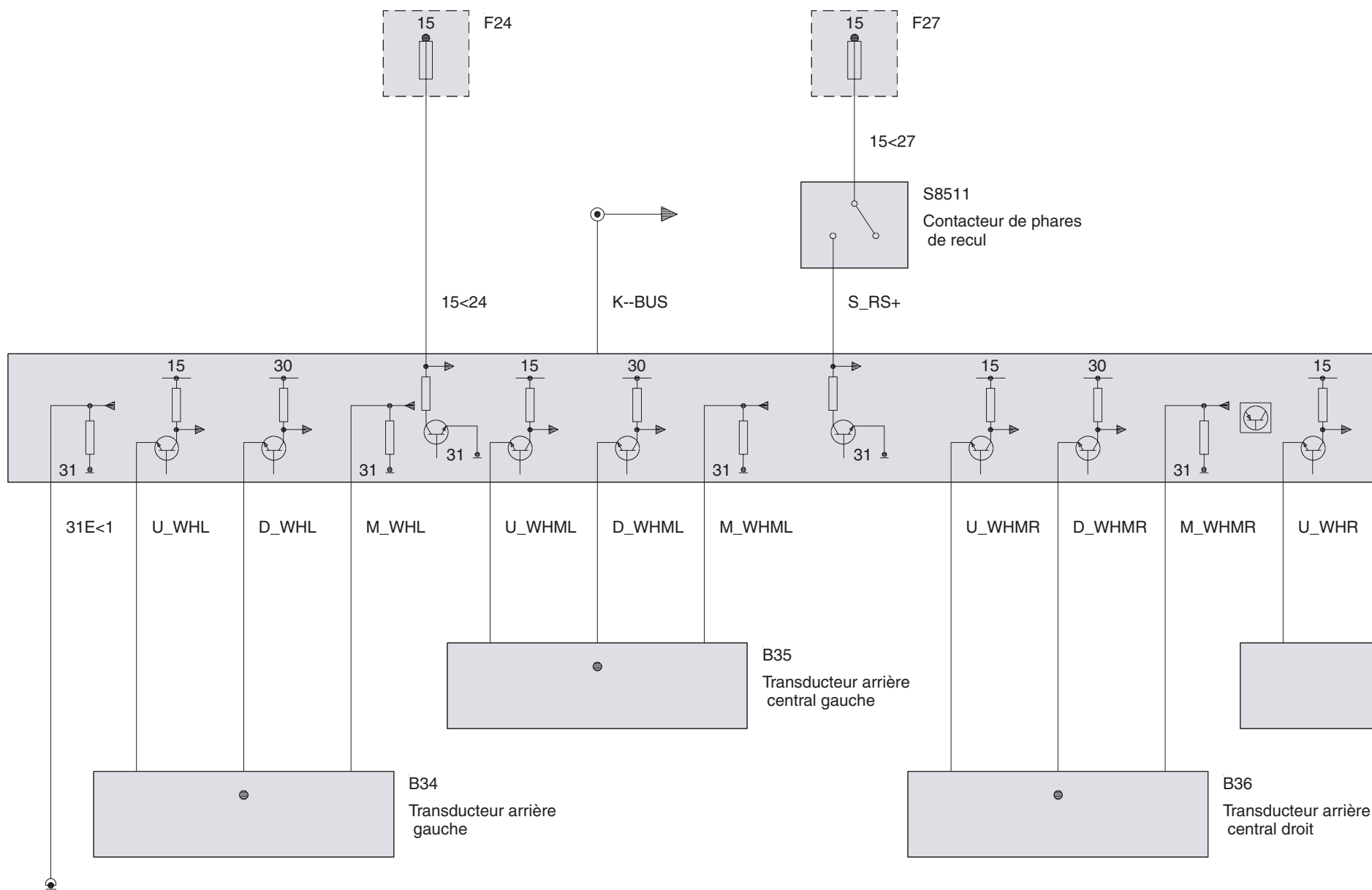



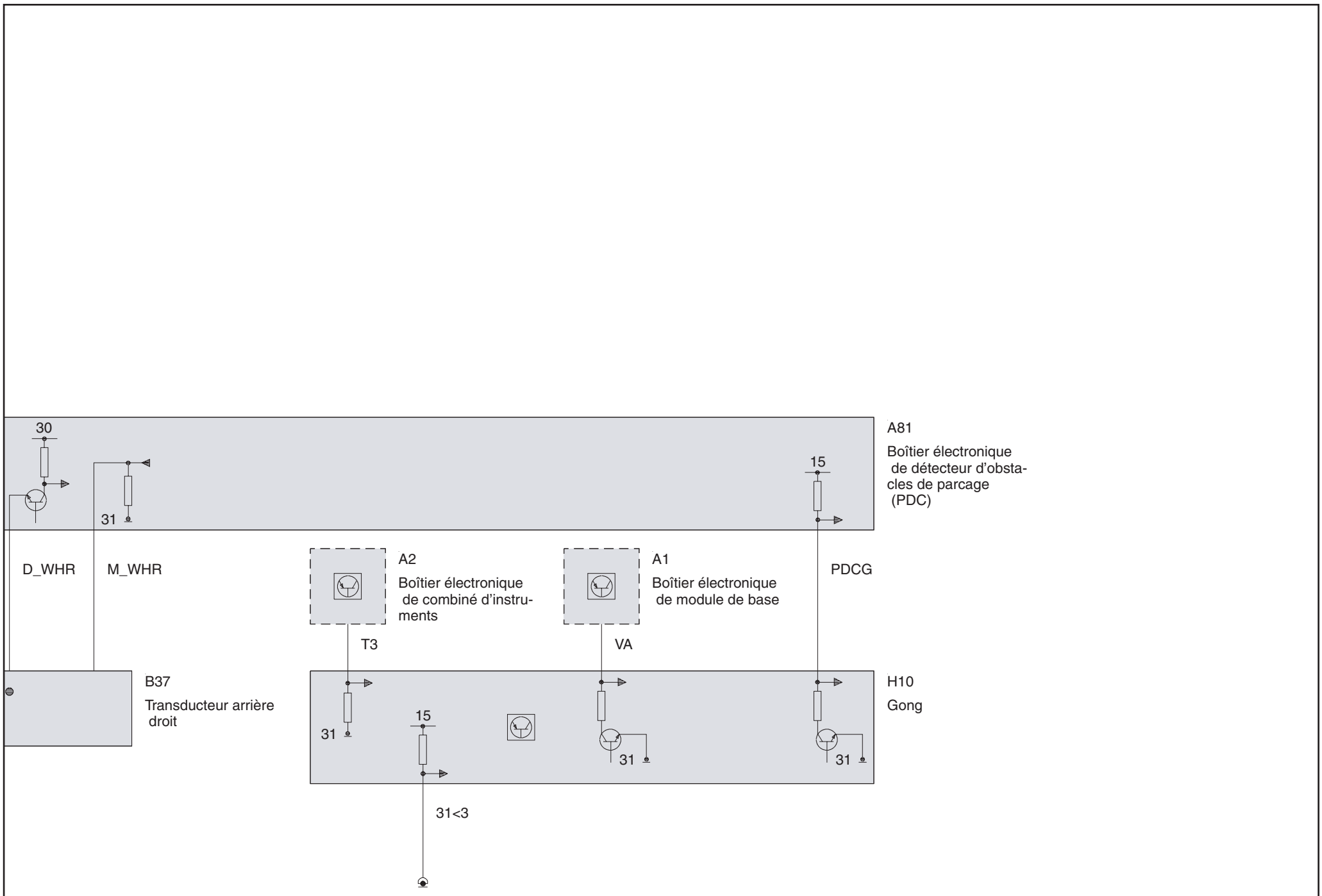

Signalisation acoustique de distance (Essence avec Boîte automatique jusque 2003\_03)

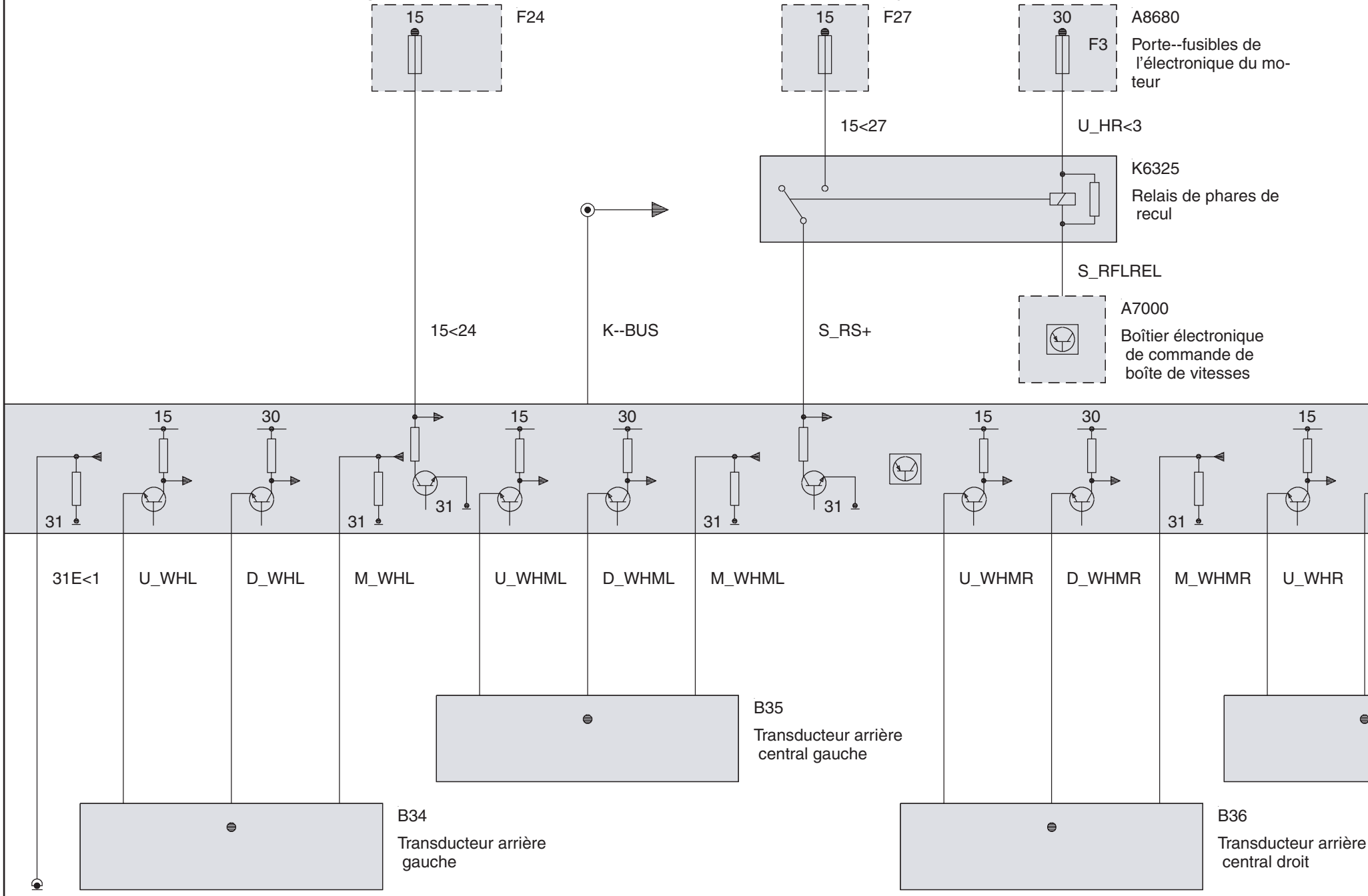

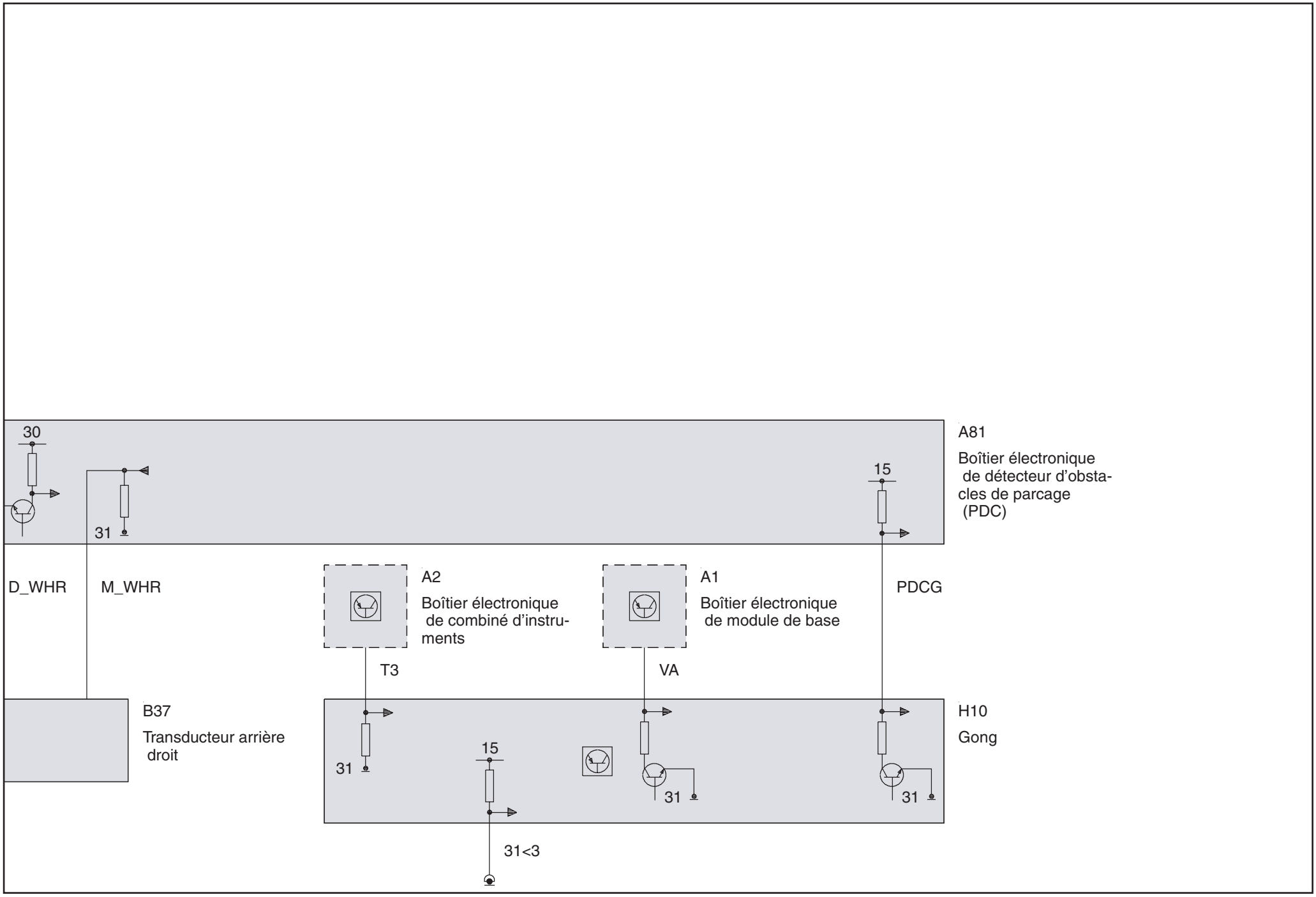

Signalisation acoustique de distance (Diesel jusque 2003\_03)

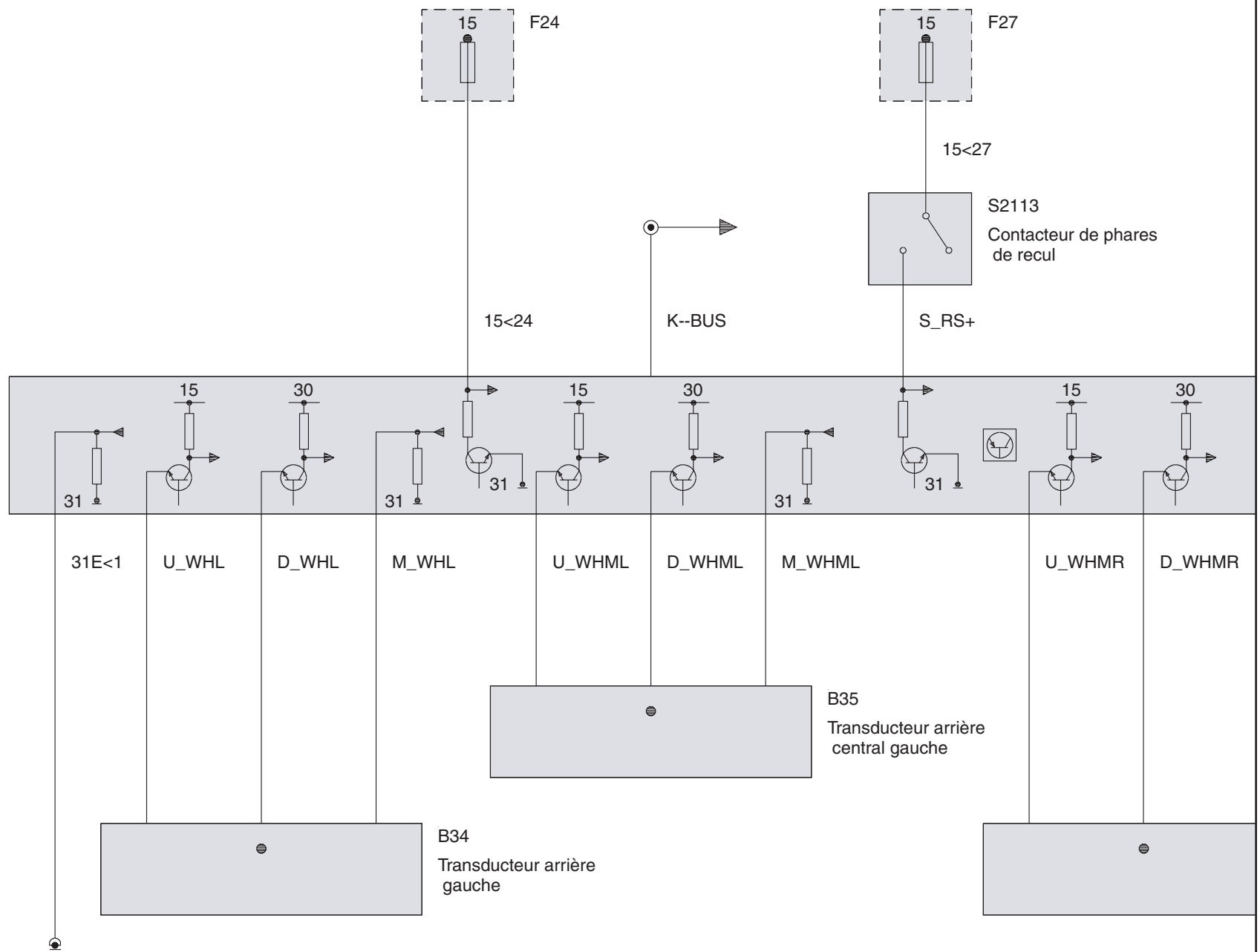

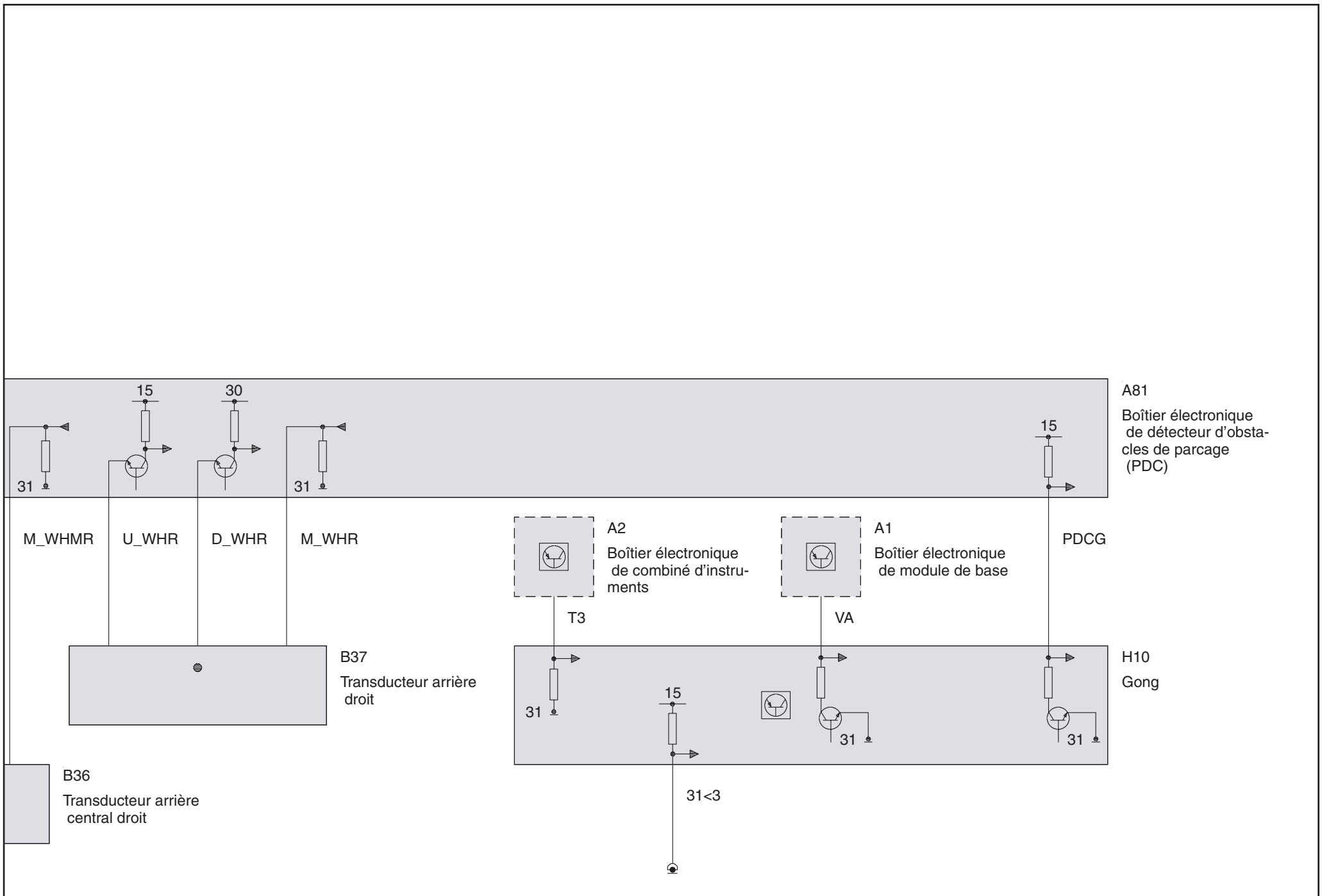

Signalisation acoustique de distance (à partir de 2003\_03)

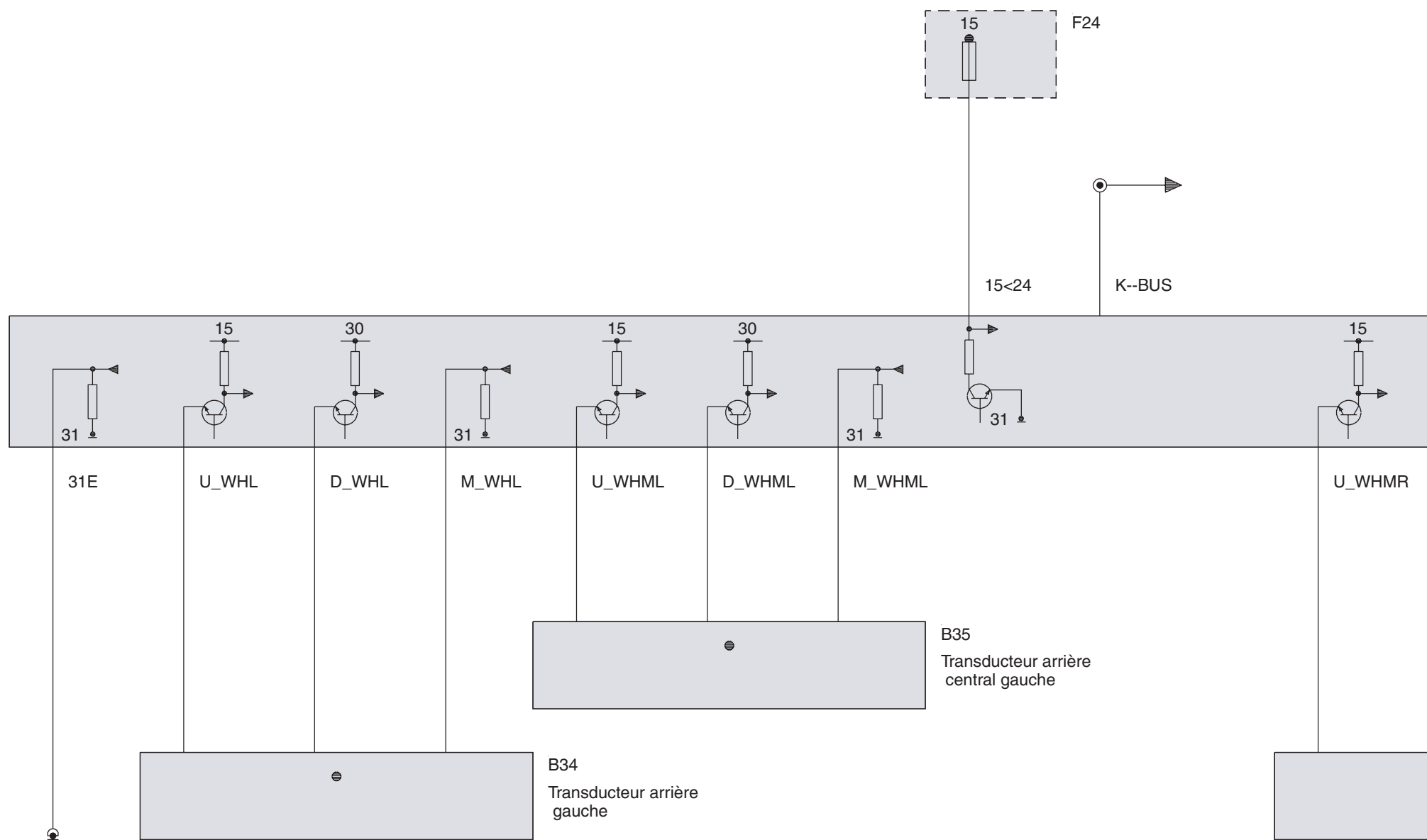

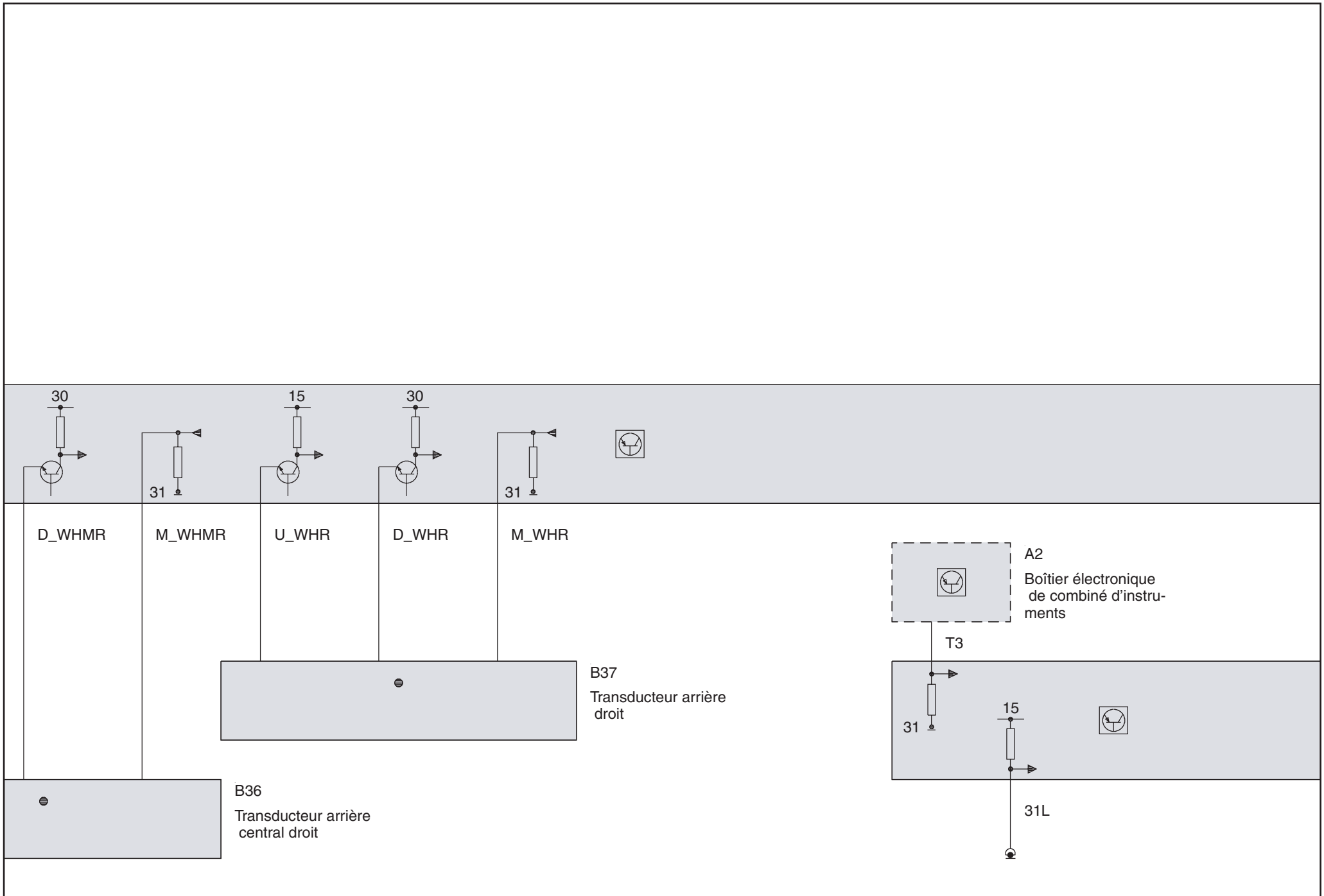

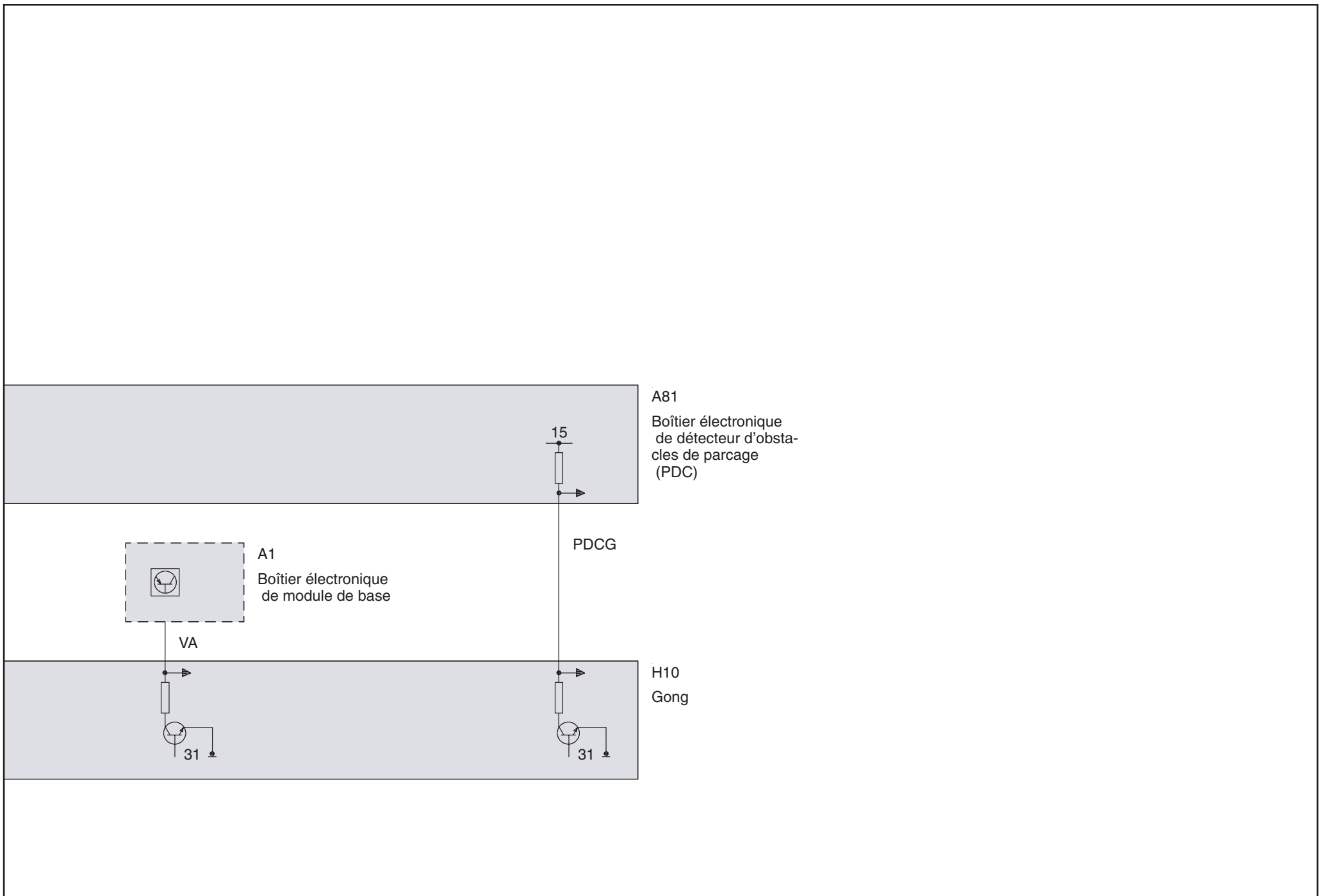



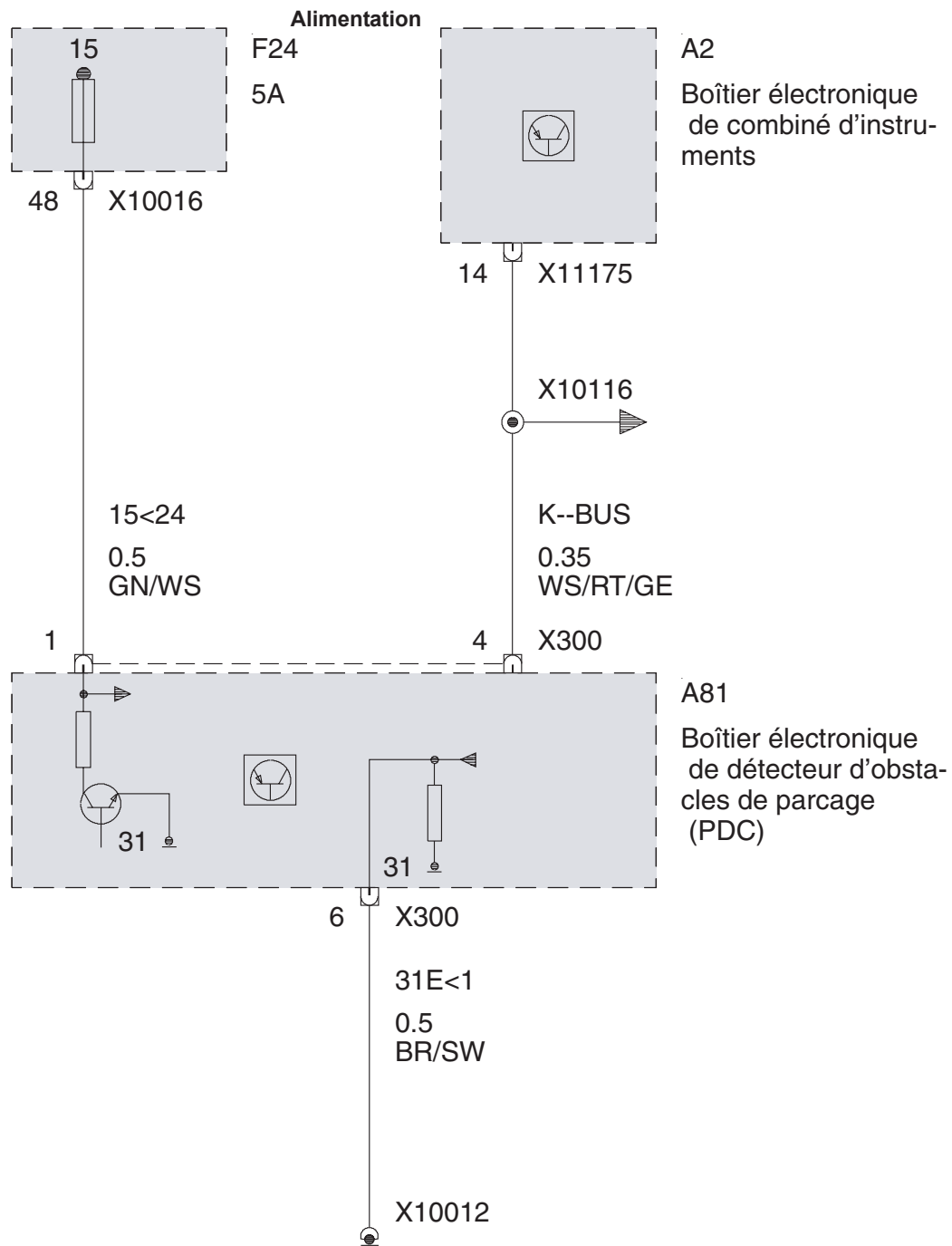

Transducteur à ultrason arrière

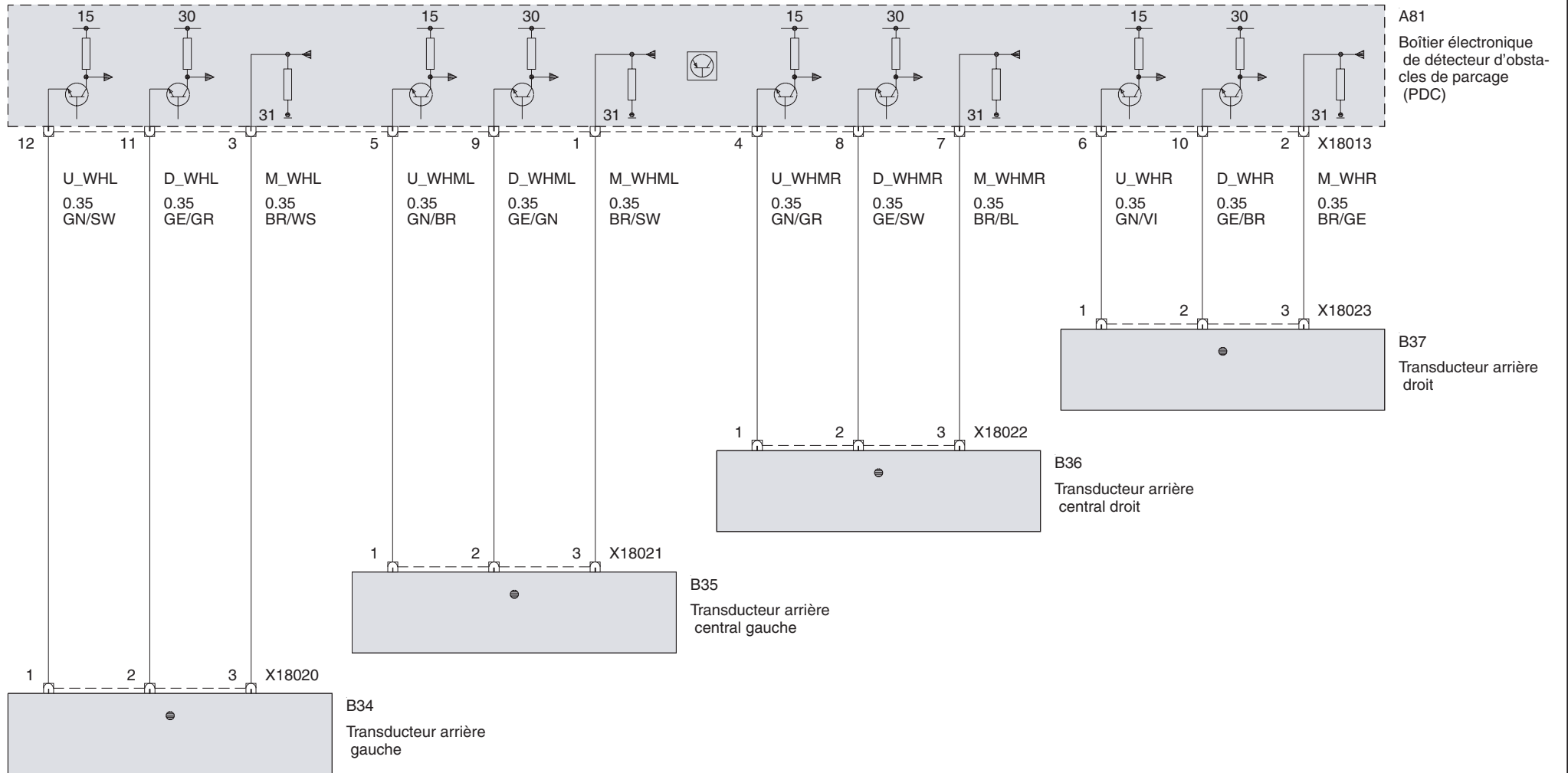

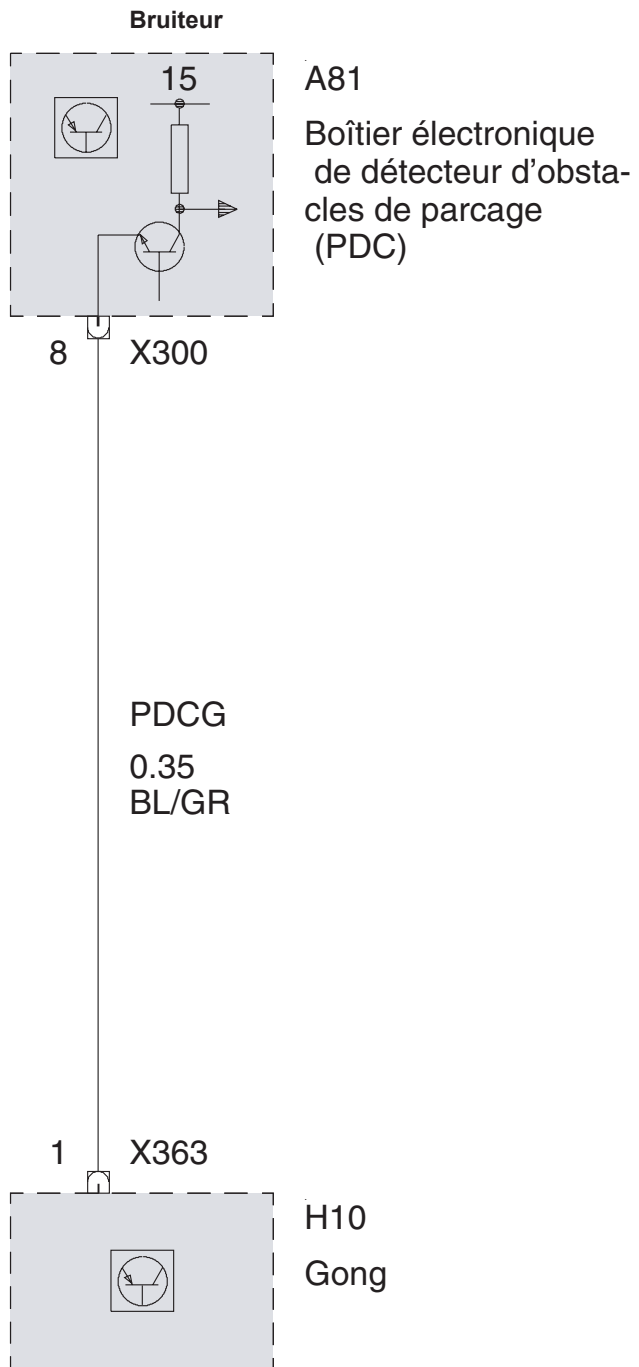

## Fonctions sièges/colonne de direction/rétroviseurs

## Réglage du siège conducteur

Réglage siège conducteur à mémoire (SMF Mémoire de la position de siège conducteur)

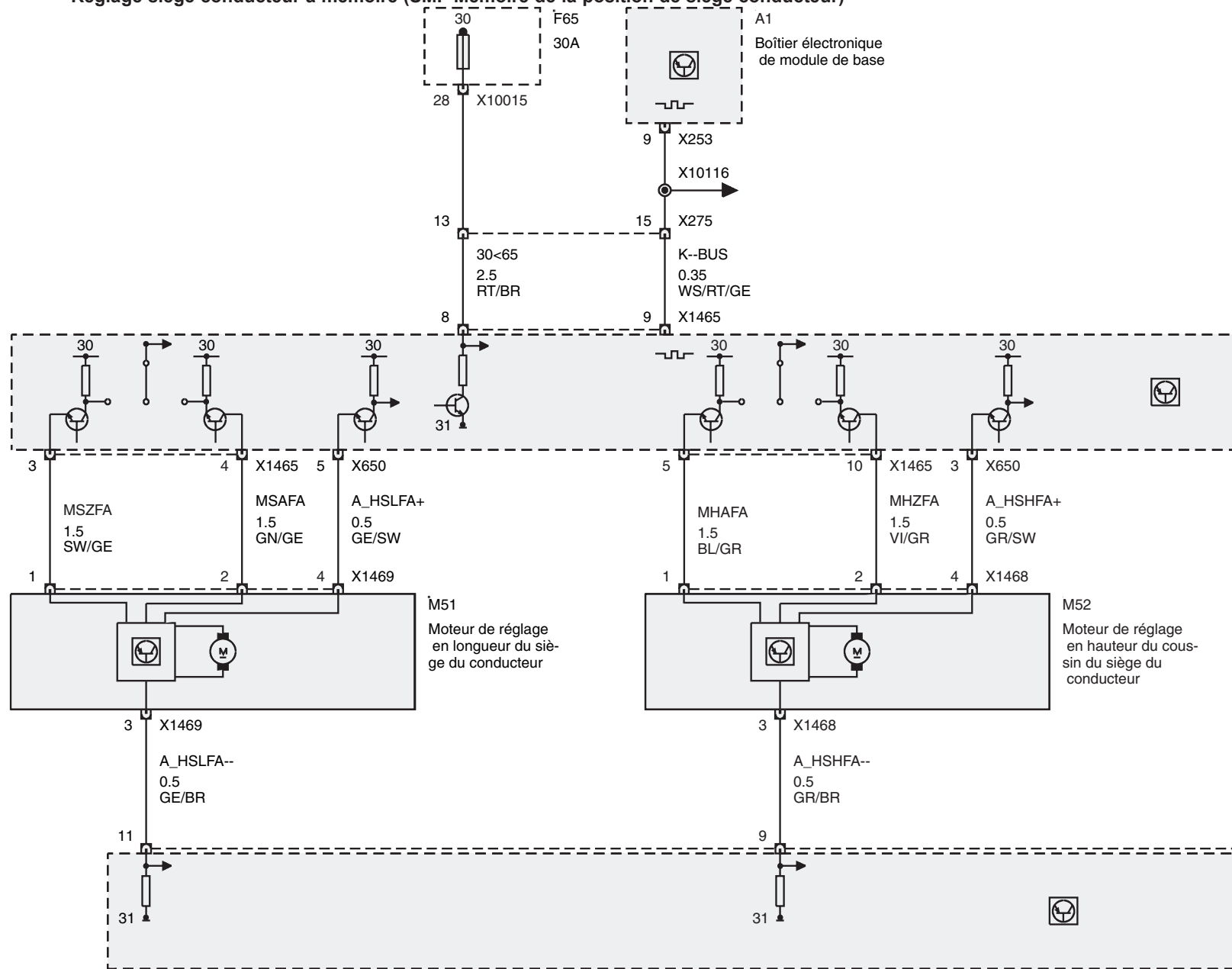

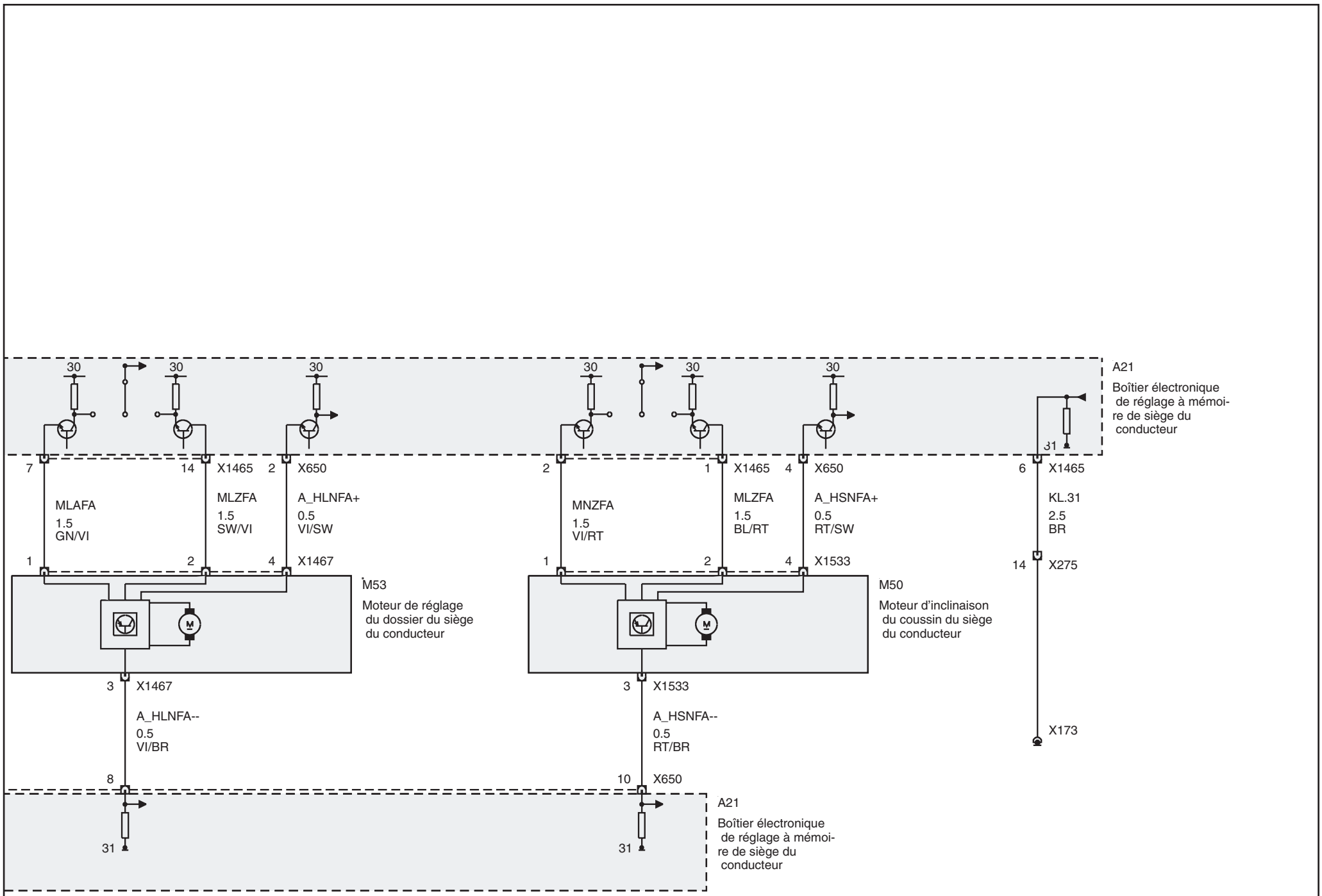

Réglage siège conducteur sans mémoire (sans SMF)

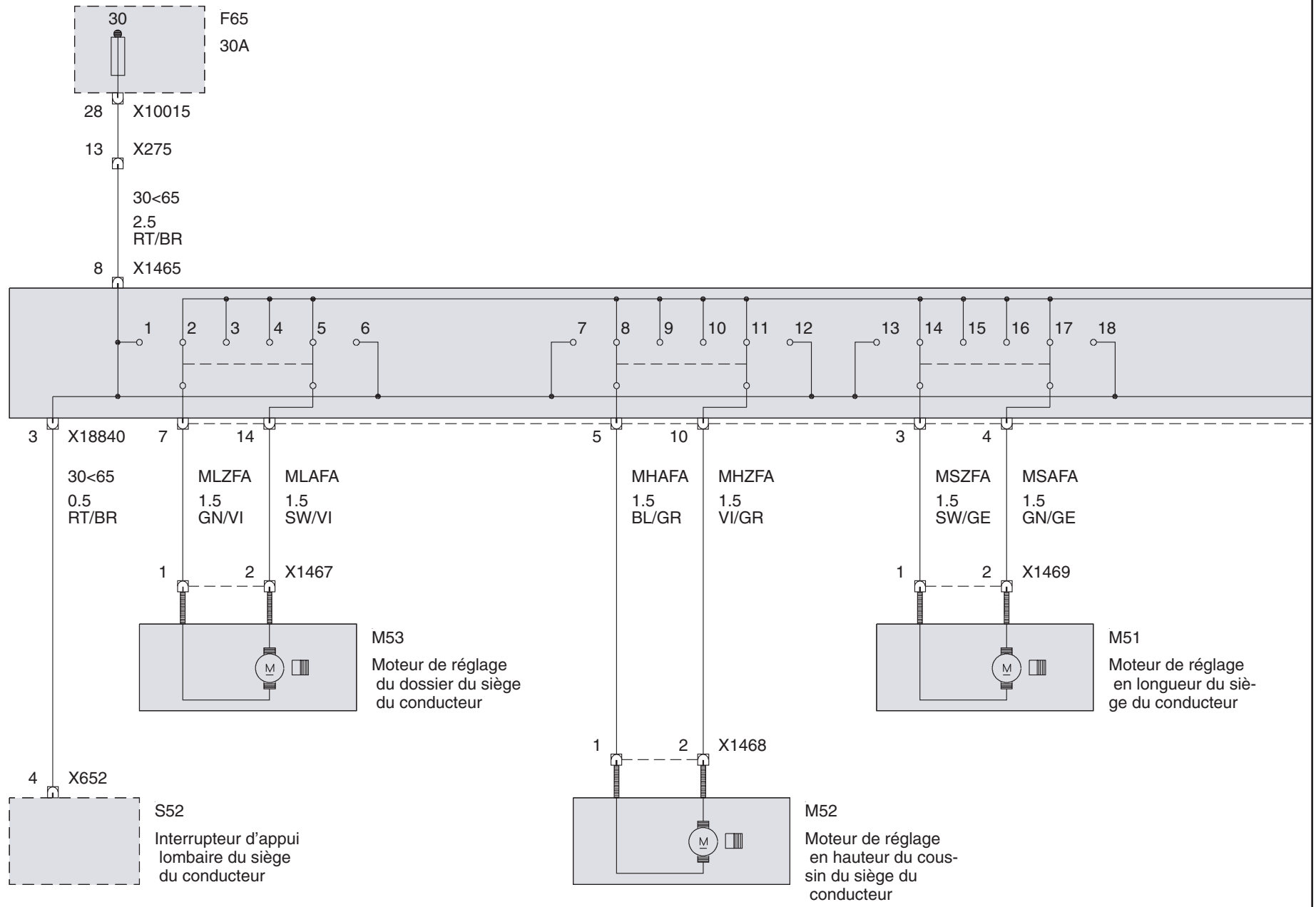

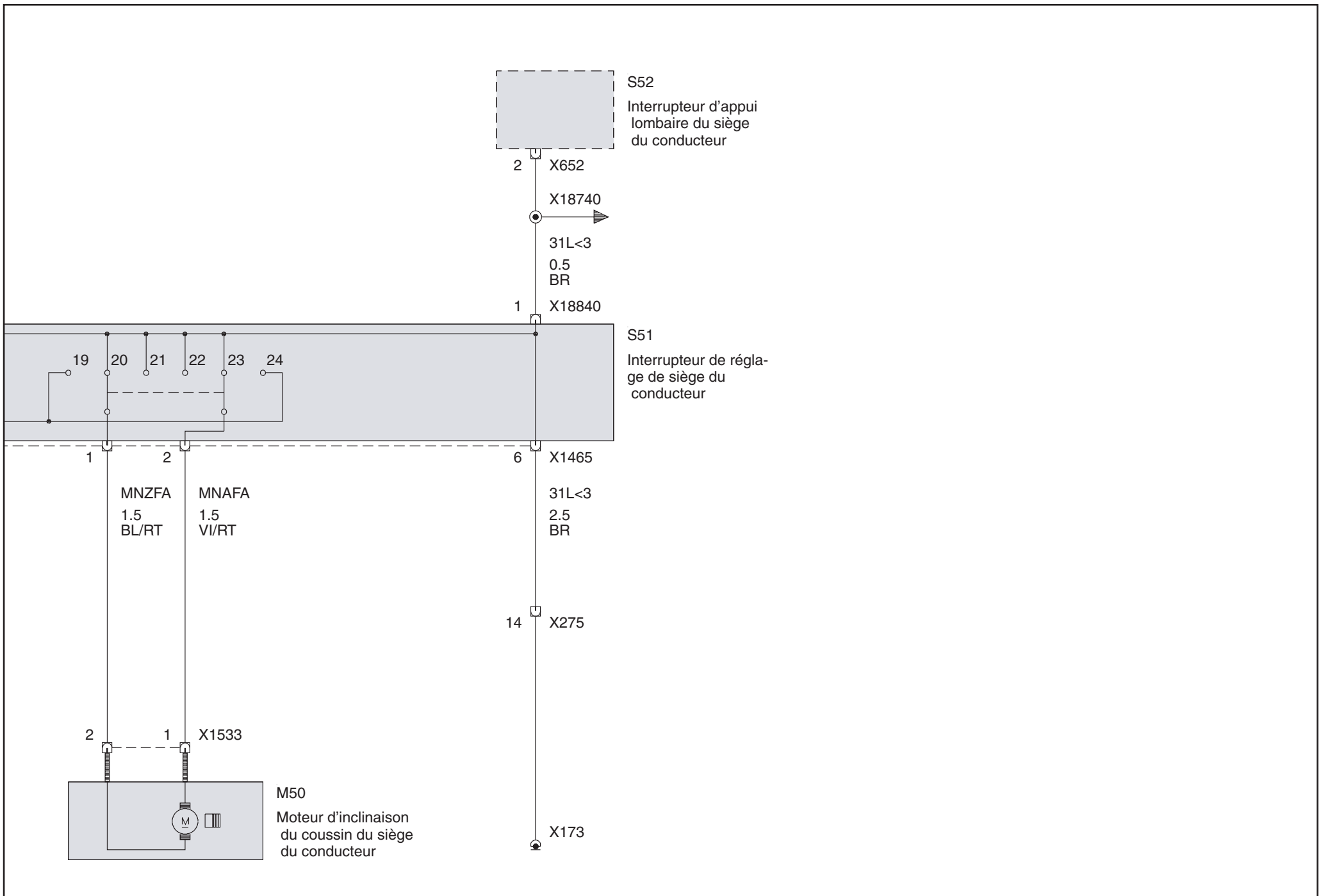

**Réglage du siège passager**  
 Réglage siège passager (Berline ou Touring ou Compact)

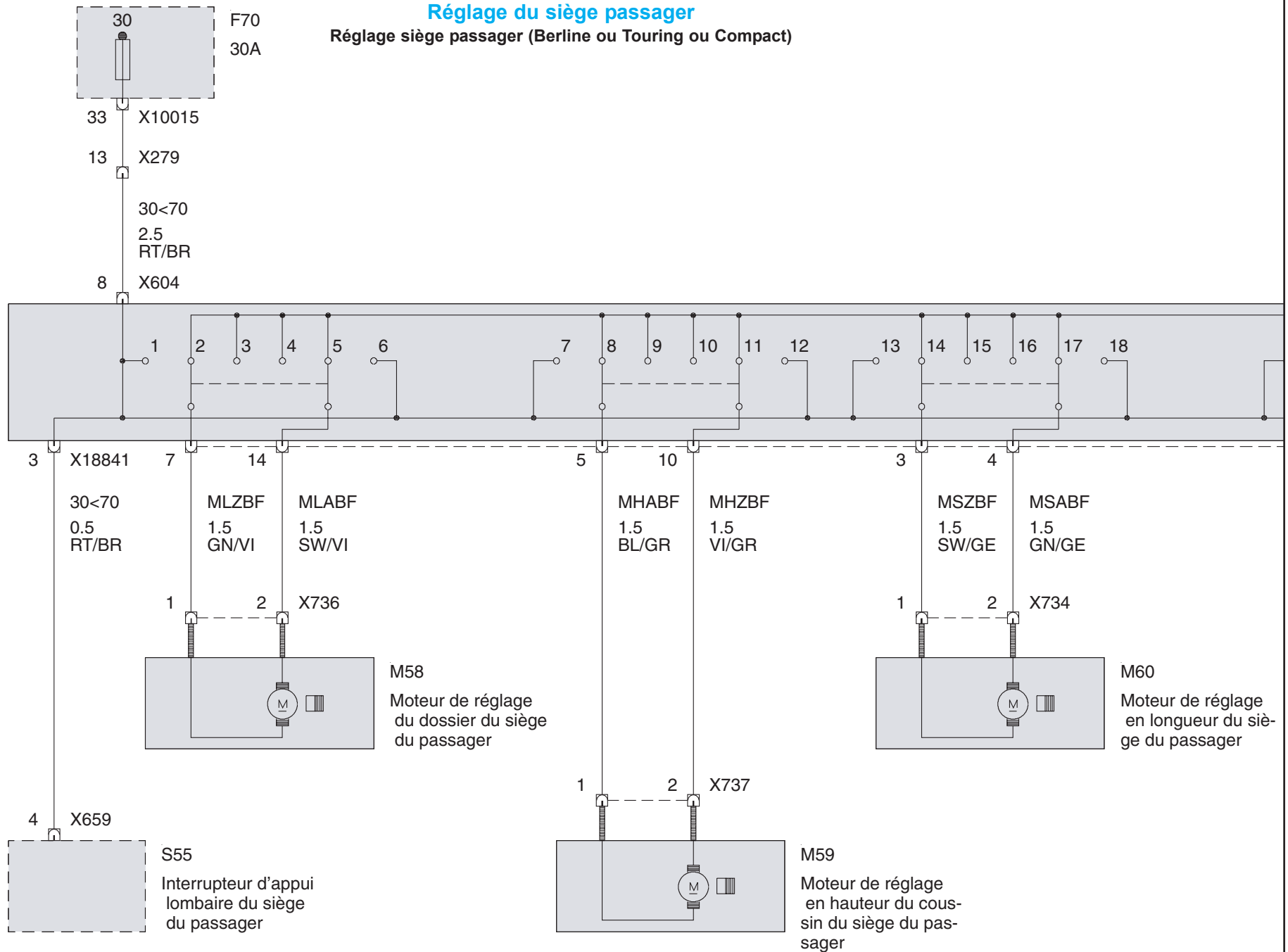



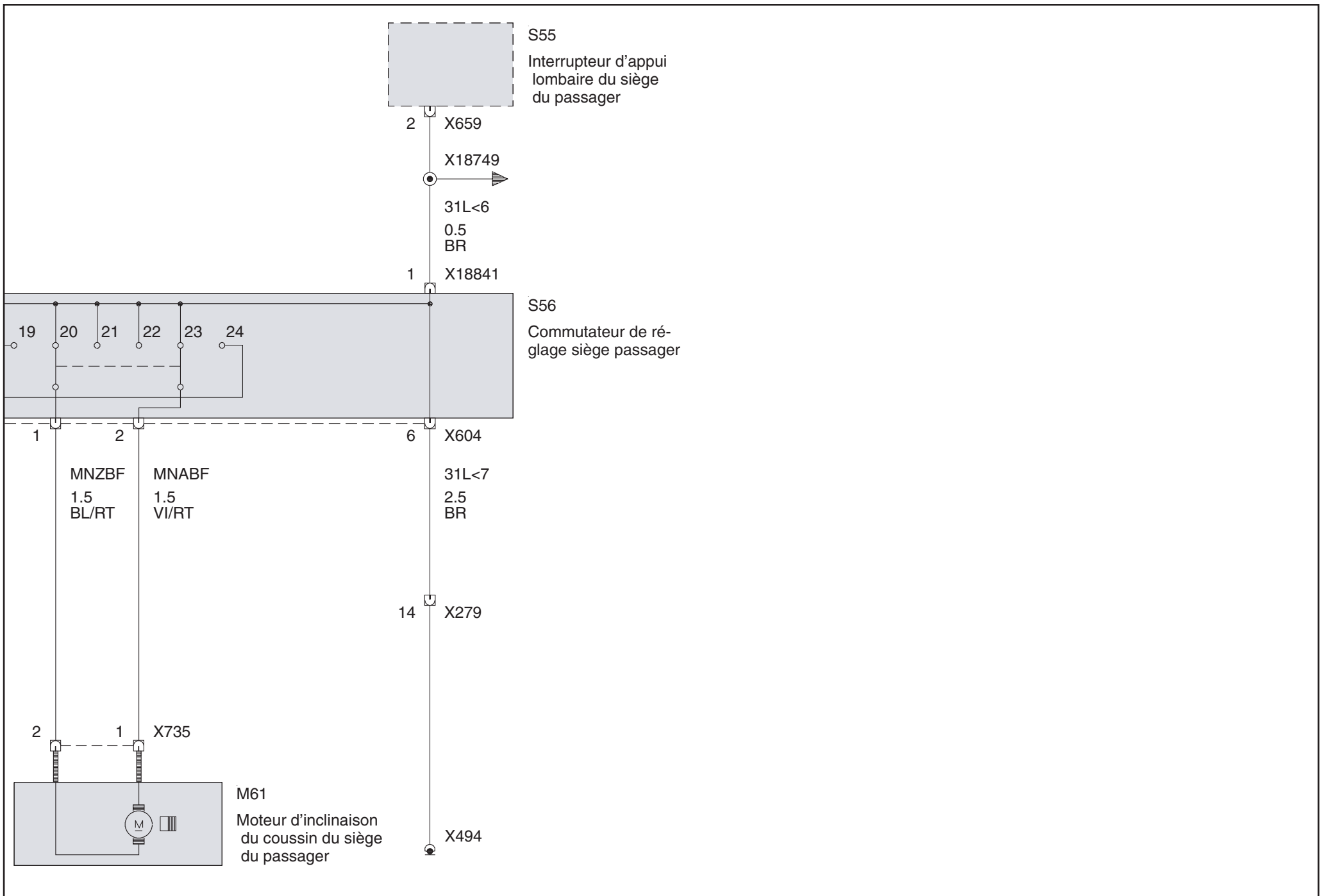

Réglage siège passager (Coupé)

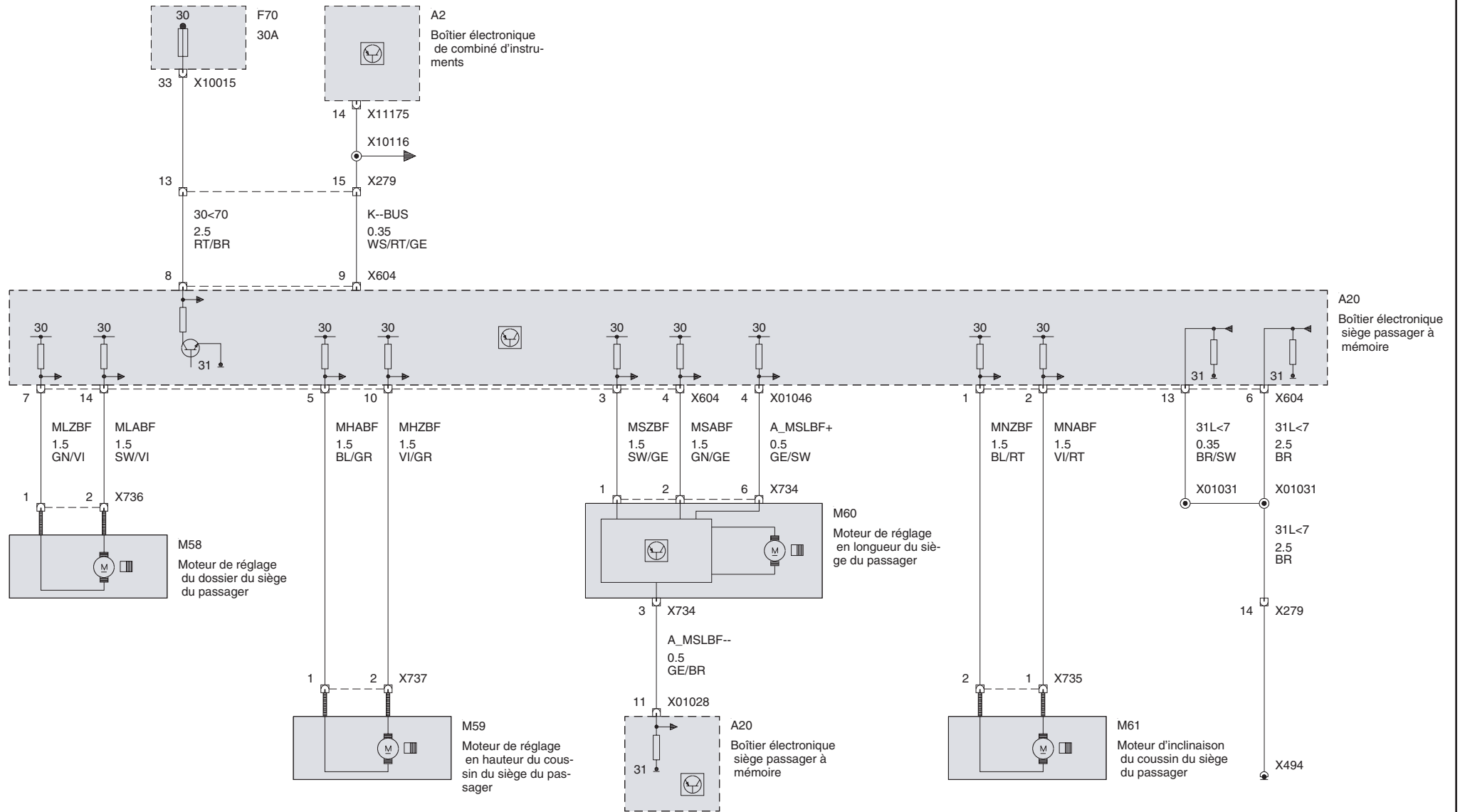



Chauffage siège passager

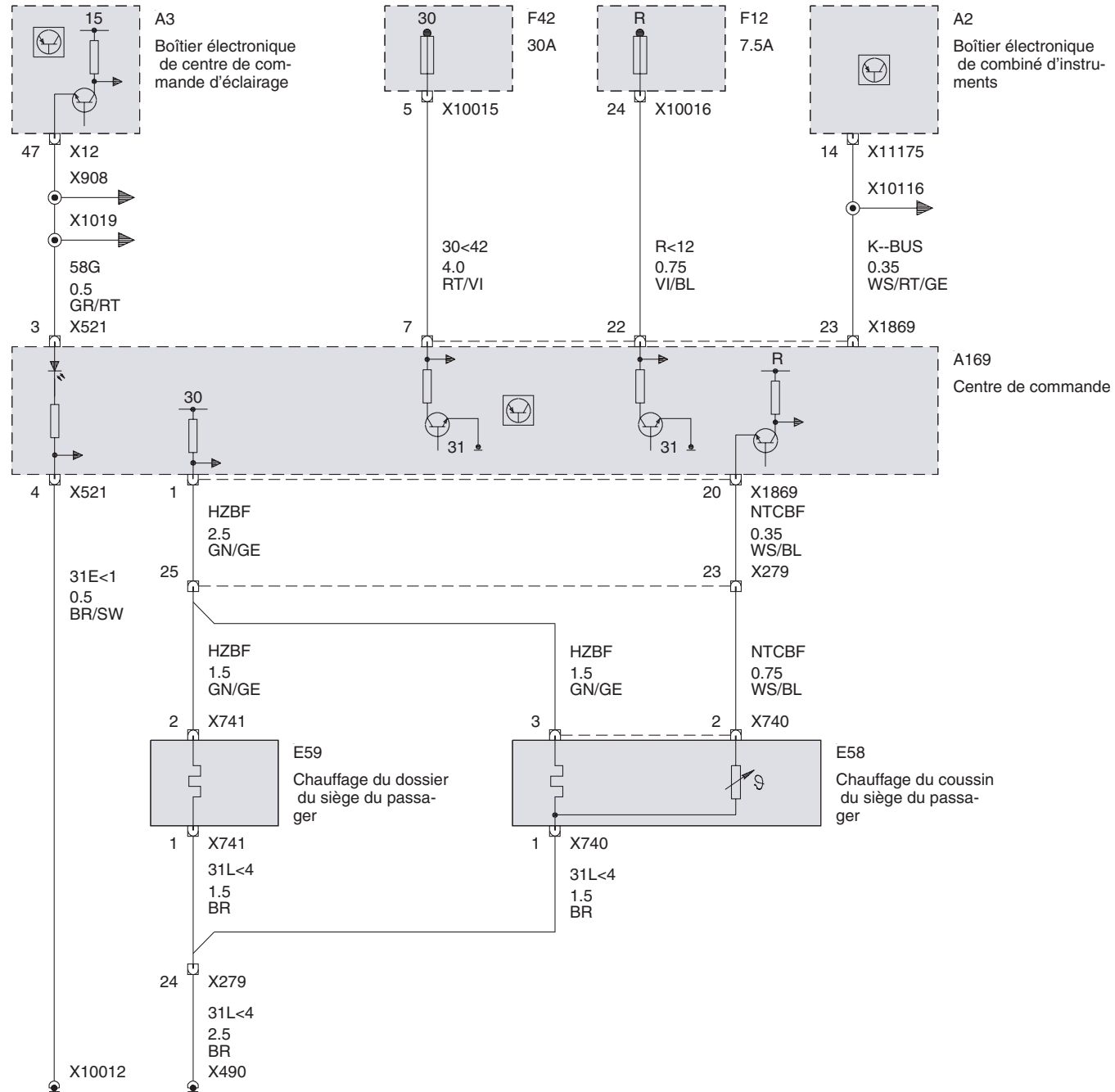

### Appui lombaire

#### Appui lombaire du conducteur avec réglage à mémoire (SMF)

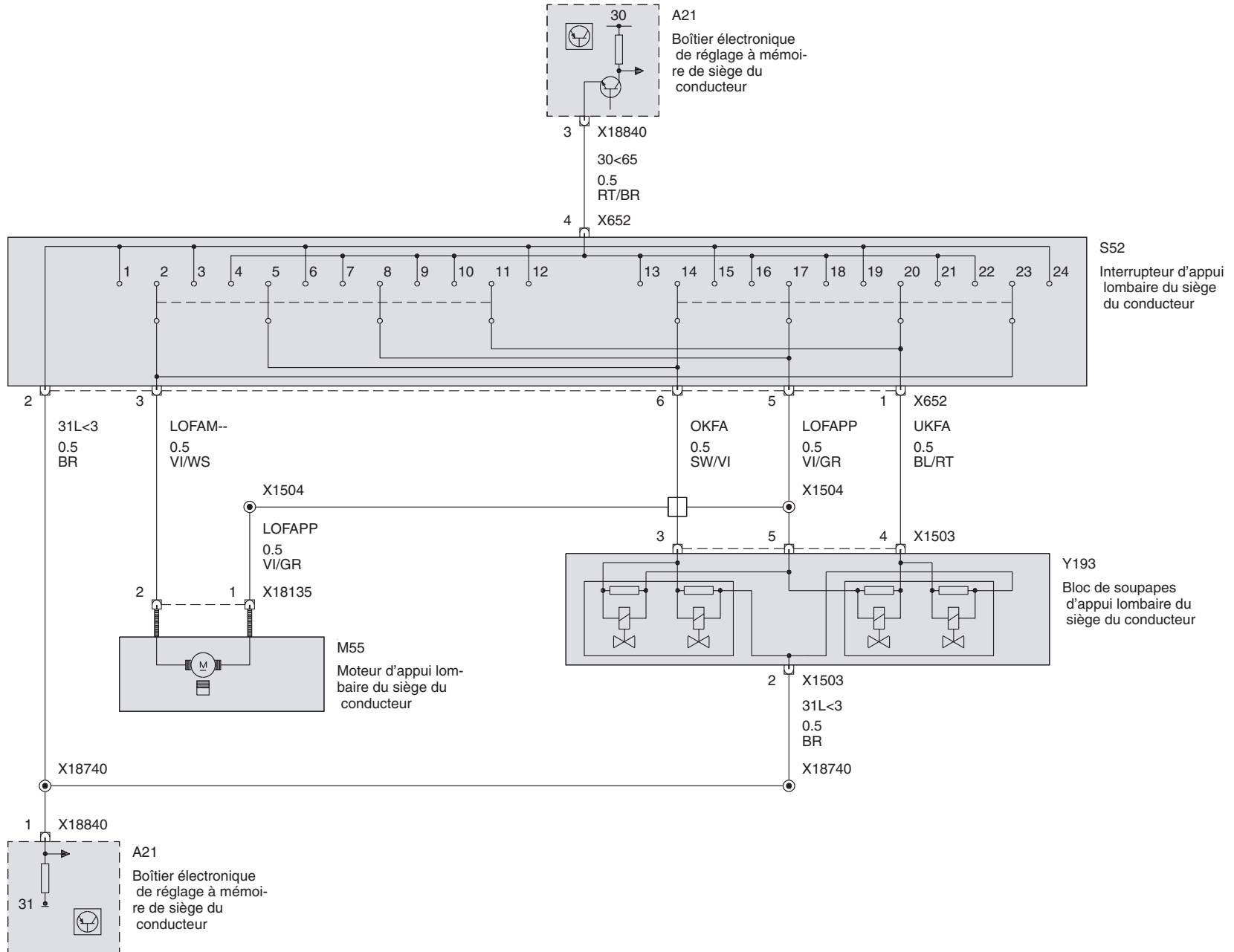

Appui lombaire du conducteur avec réglage sans mémoire (sans SMF)

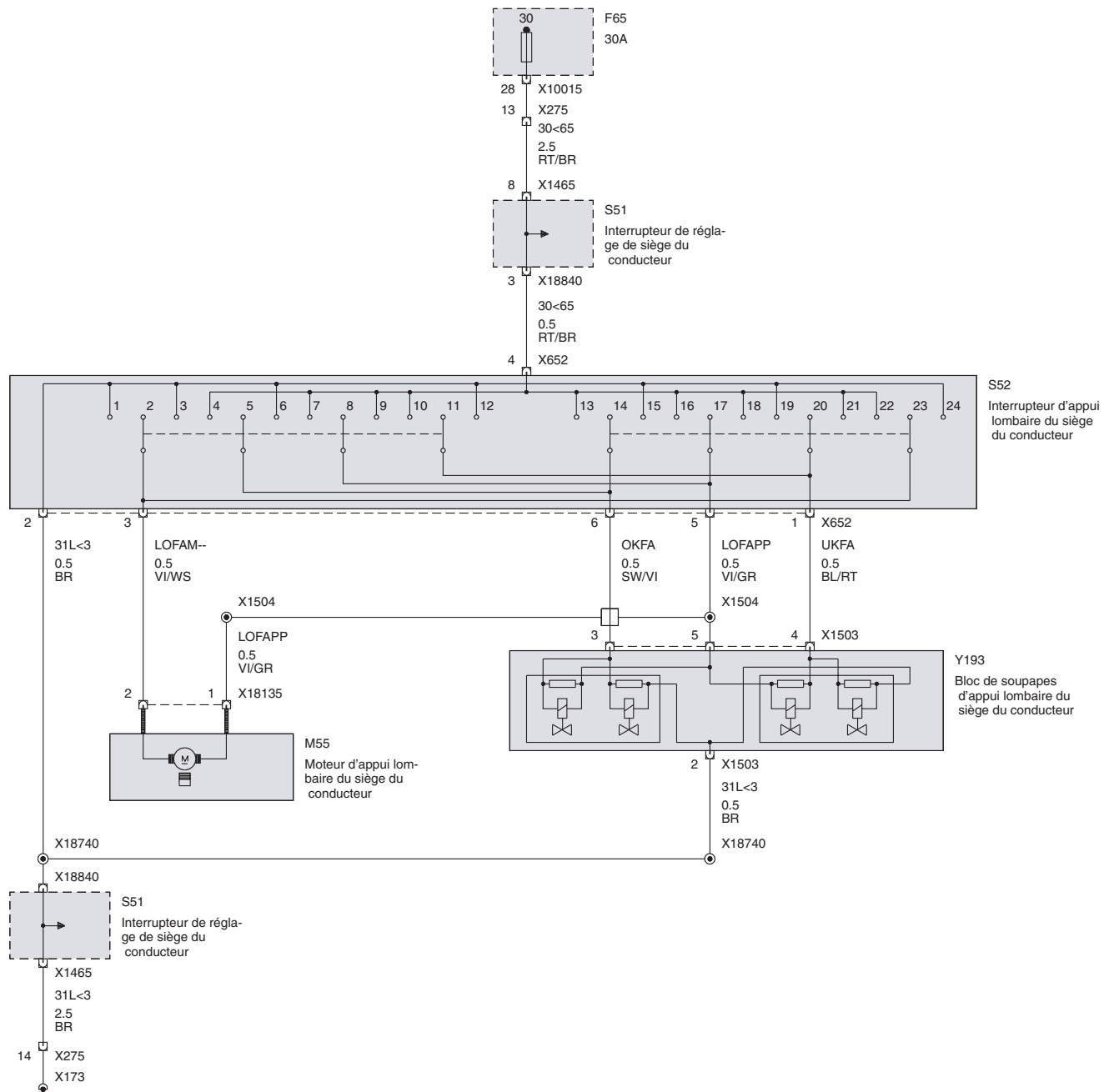

Appui lombaire du passager avec réglage à mémoire (SMF (Berline ou Touring))

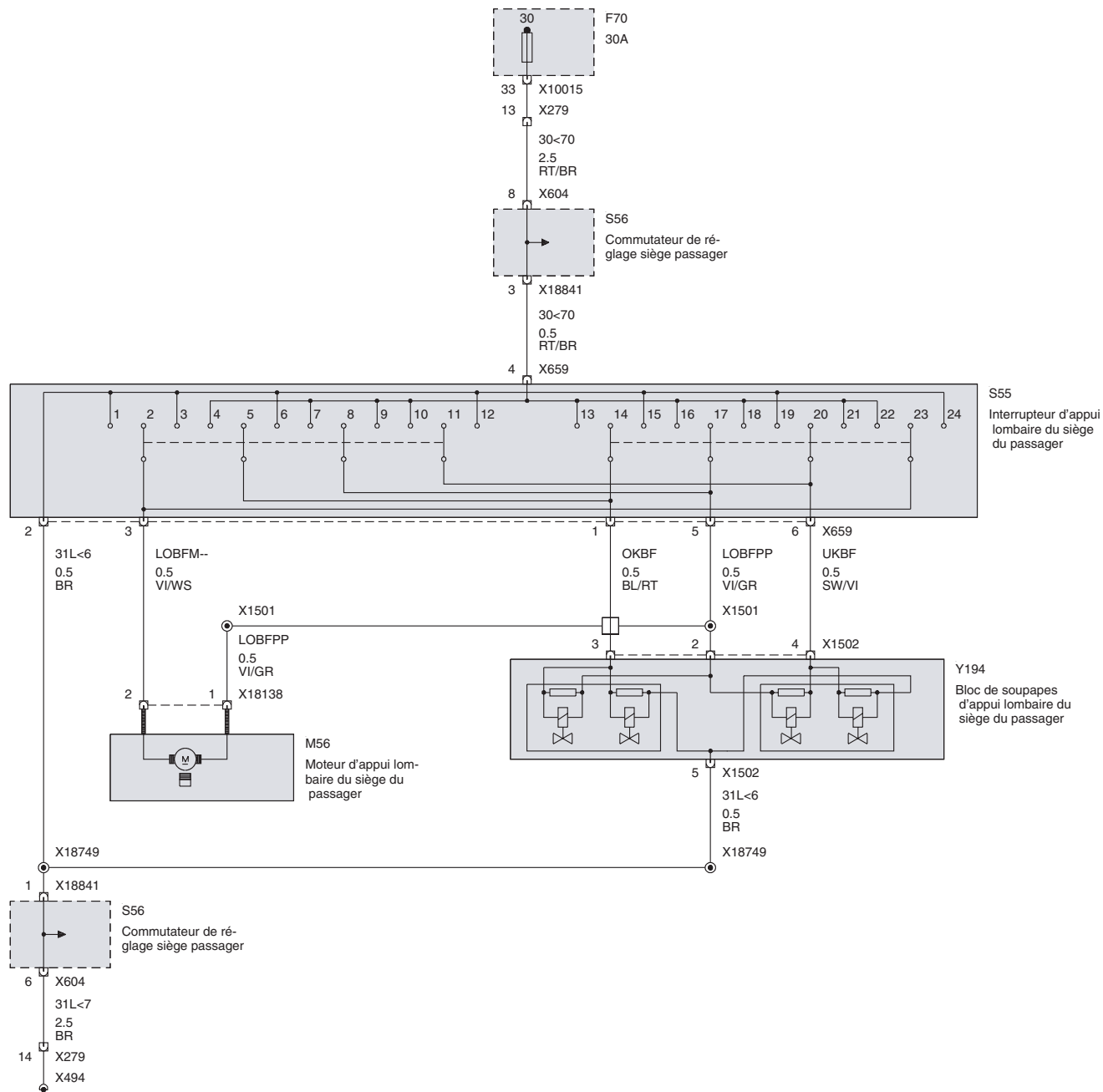

Appui lombaire du passager avec réglage à mémoire (SMF (Coupé ou Compact))

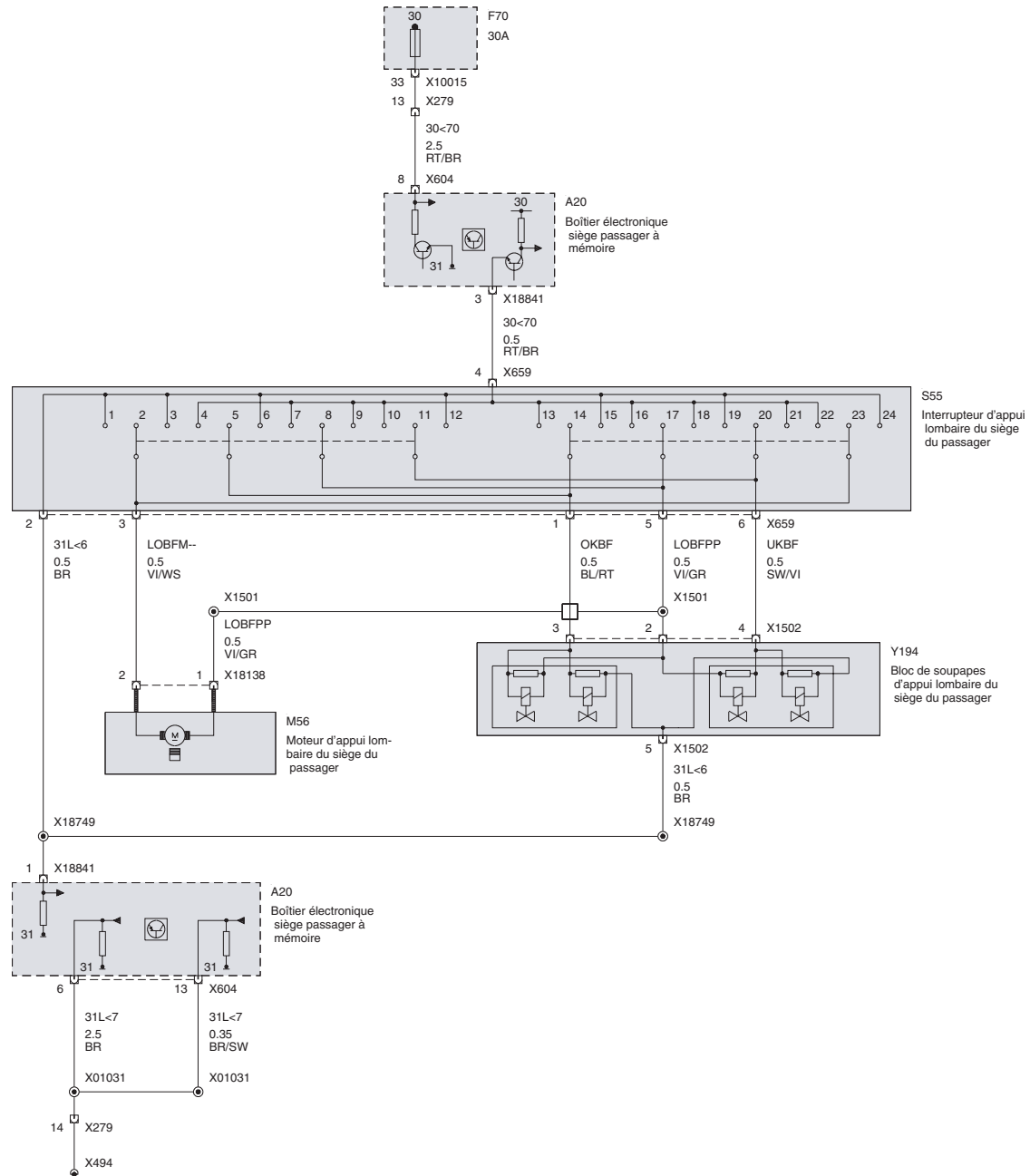



Appui lombaire du passager avec réglage sans mémoire (sans SMF)

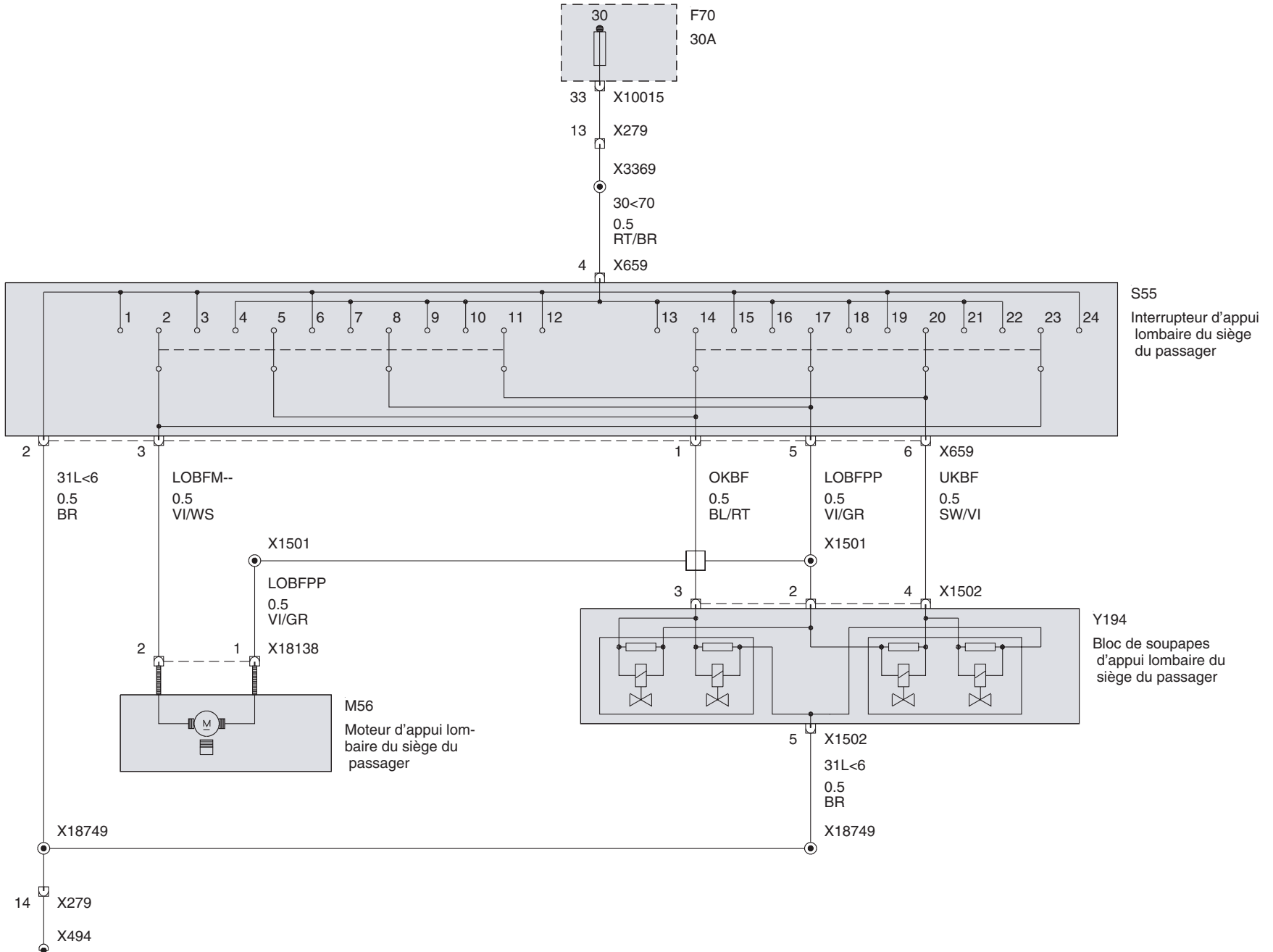



Rétroviseur extérieur avec commande électrique à mémoire, côté conducteur (( Berline ou Touring ou Compact à partir de 2003\_03) (Coupé ou Cabriolet à partir de 2003\_09))

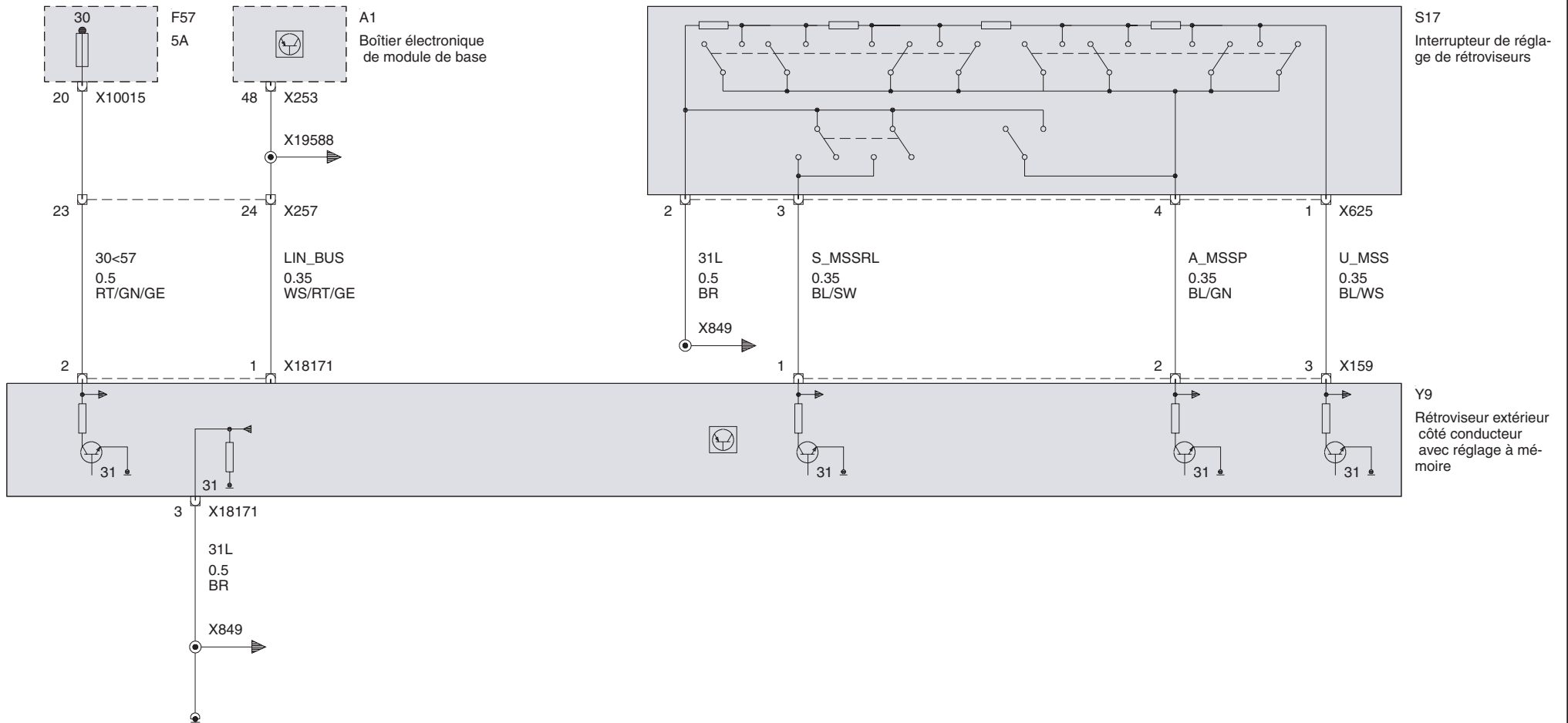

Rétroviseurs extérieurs électriques sans mémoire (sans SPMFT Mémoire rétroviseur conducteur ou SMF)

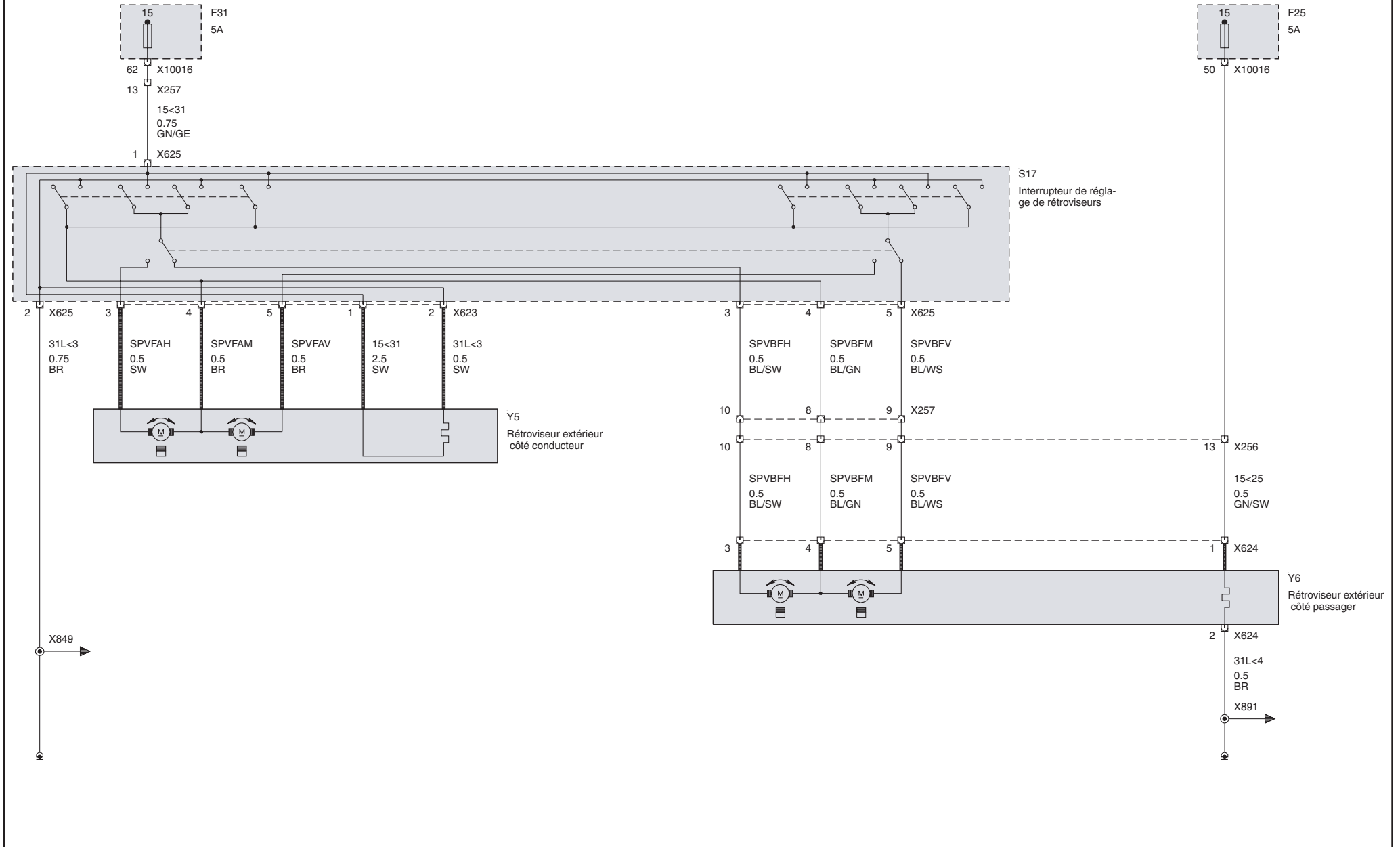

Rabattement rétroviseurs extérieurs sans mémoire (sans SPMFT ou SMF)

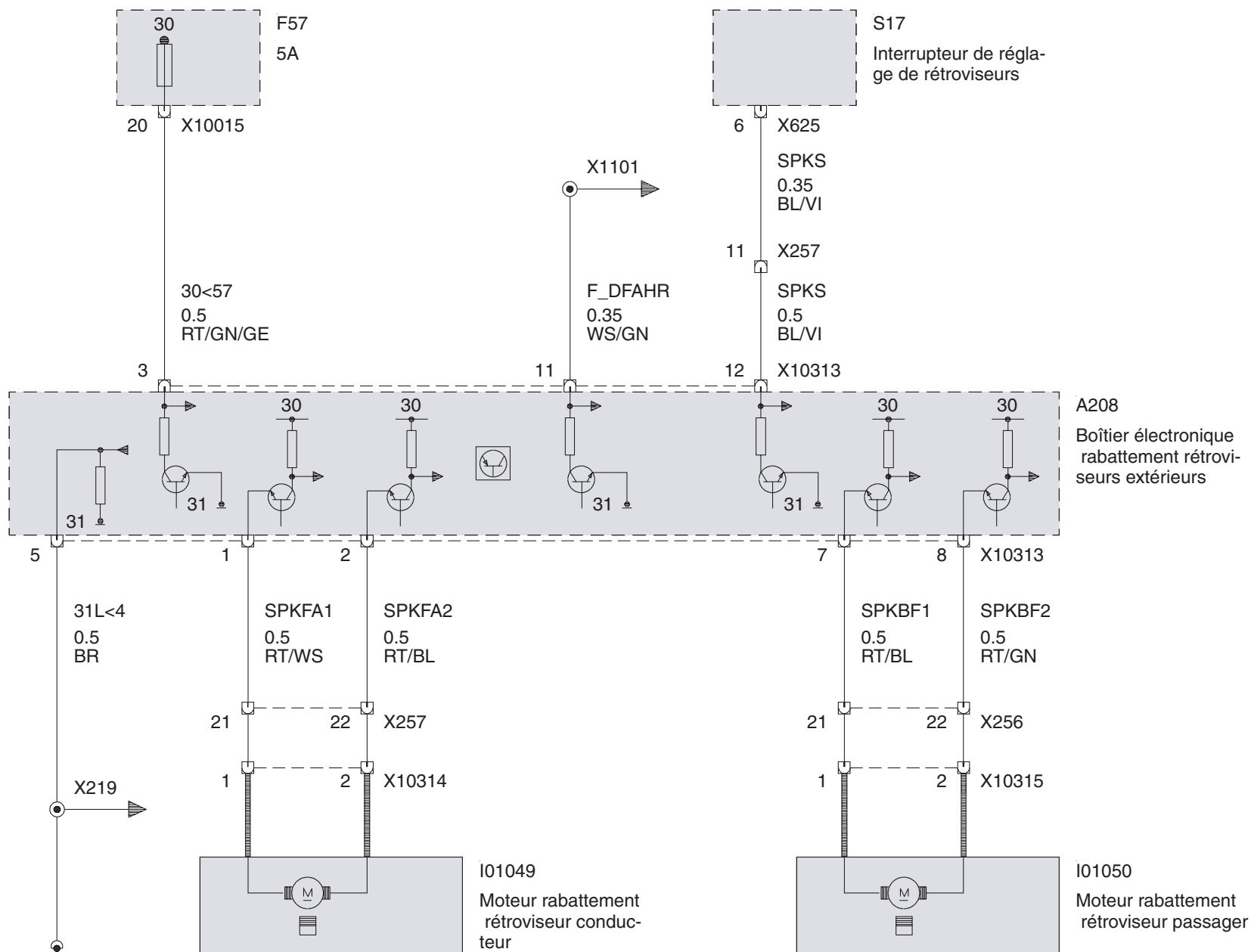

Rétroviseur extérieur avec commande électrique à mémoire, côté passager ((Berline ou Touring ou Compact jusque 2003\_03) (Coupé ou Cabriolet jusque 2003\_09))

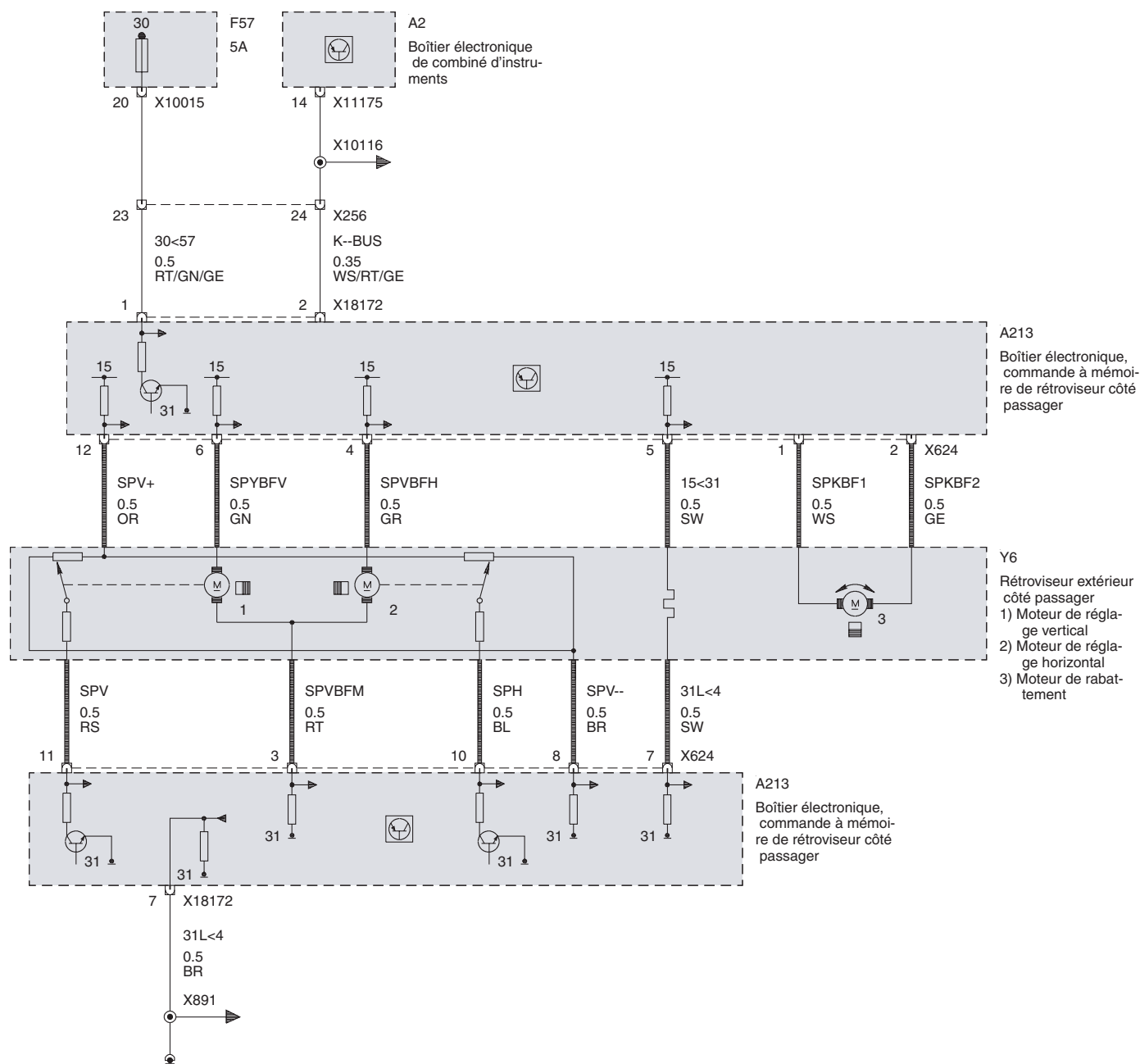

Rétroviseur extérieur avec commande électrique à mémoire, côté passager ((Berline ou Touring ou Compact à partir de 2003\_03) (Coupé ou Cabriolet à partir de 2003\_09))

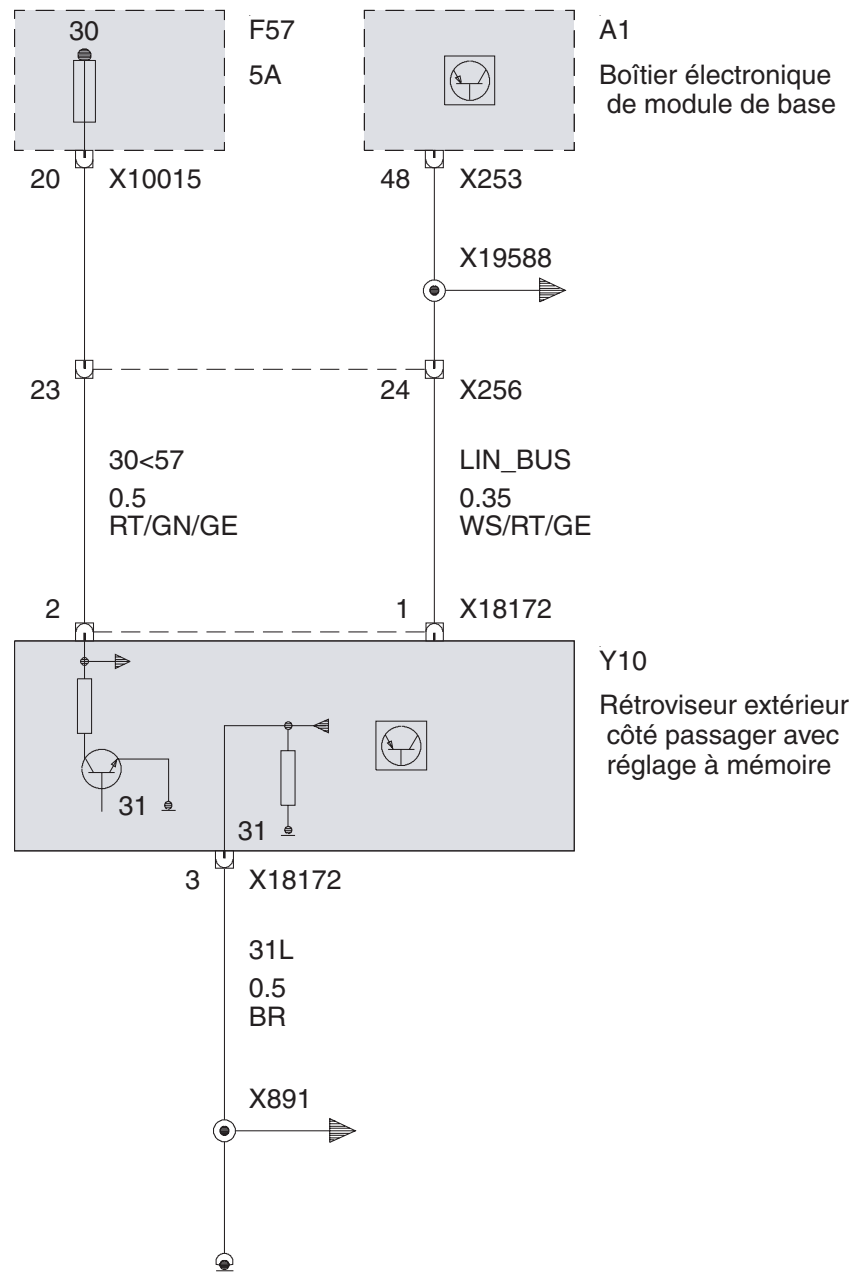

Rétroviseur intérieur

Rétroviseur intérieur électrochrome (Essence sans Boîte automatique)

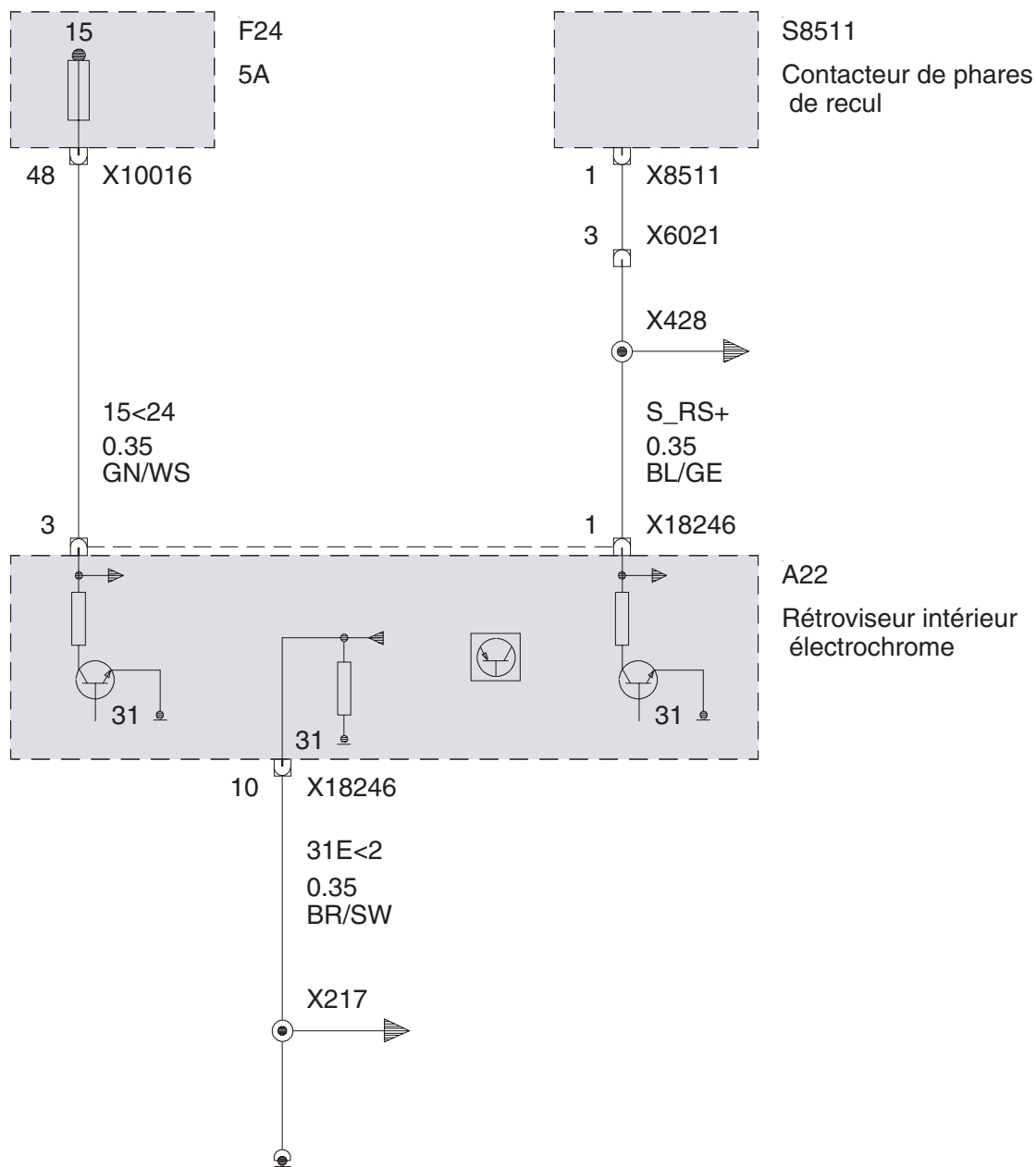



Rétroviseur intérieur électrochrome (Diesel sans Boîte automatique)

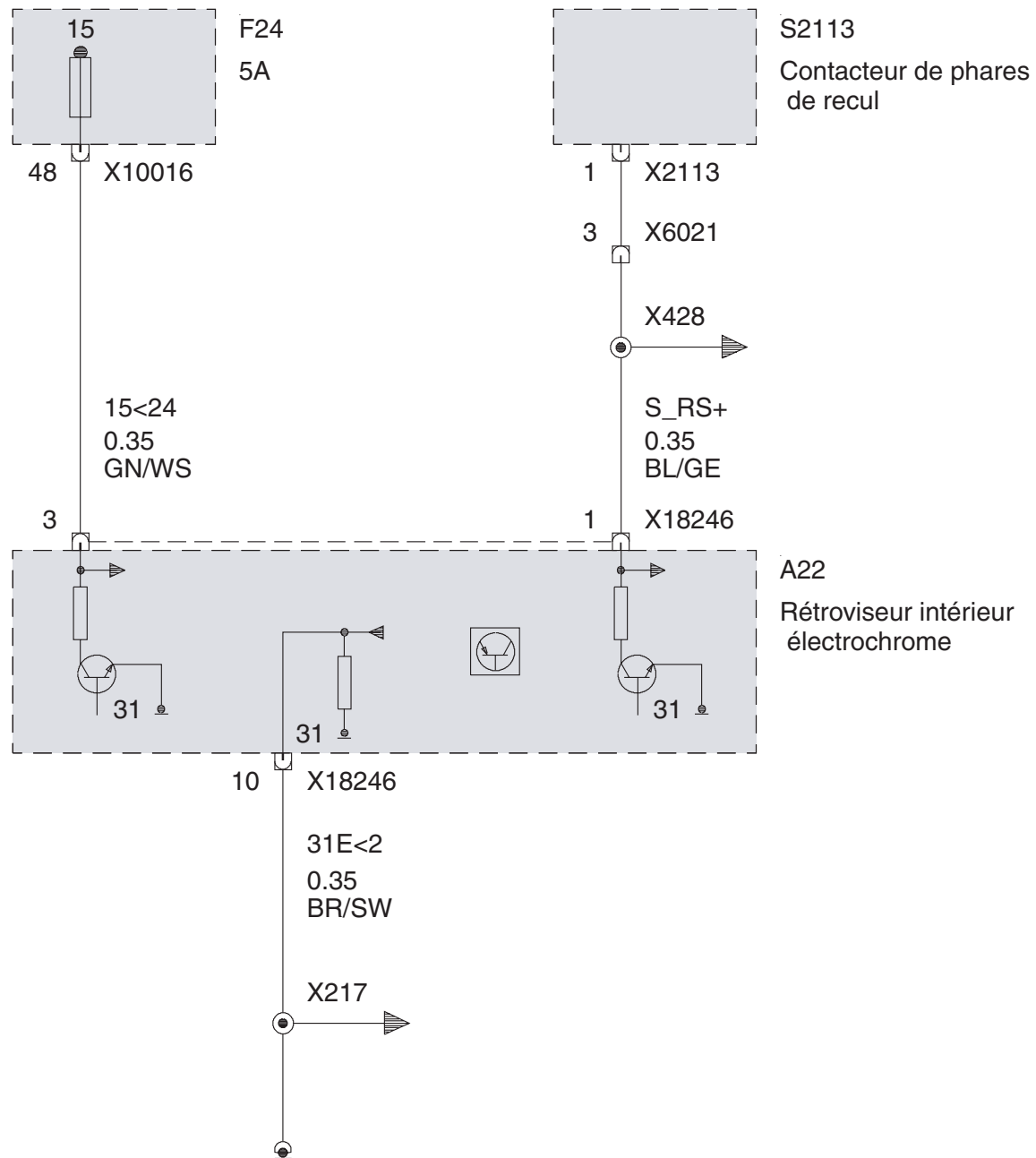

Rétroviseur intérieur électrochrome (Boîte automatique)

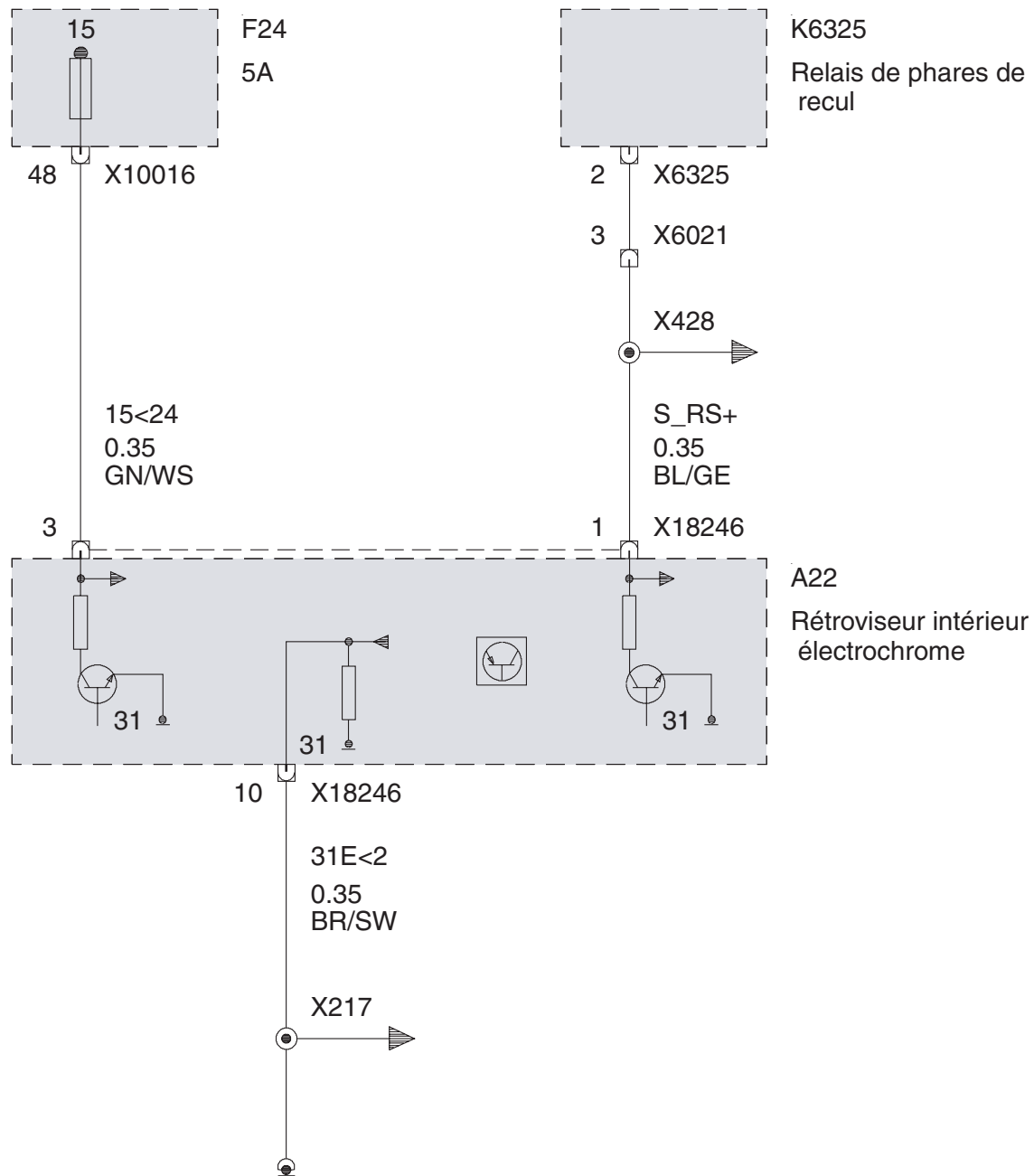

### Fonctions essuie-glace/lave-glace

Fonctions essuie-glace/lave-glace (sauf Touring)

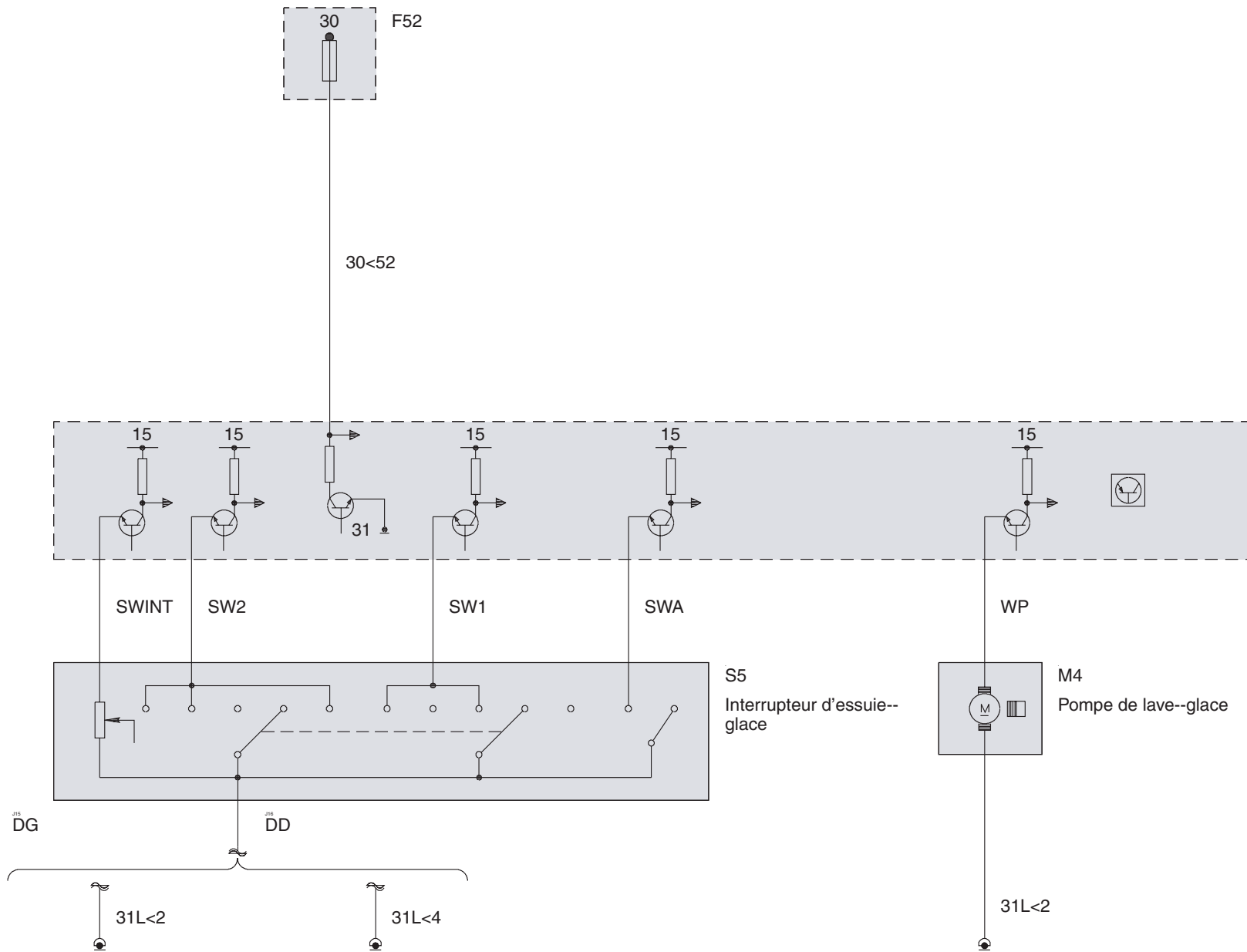

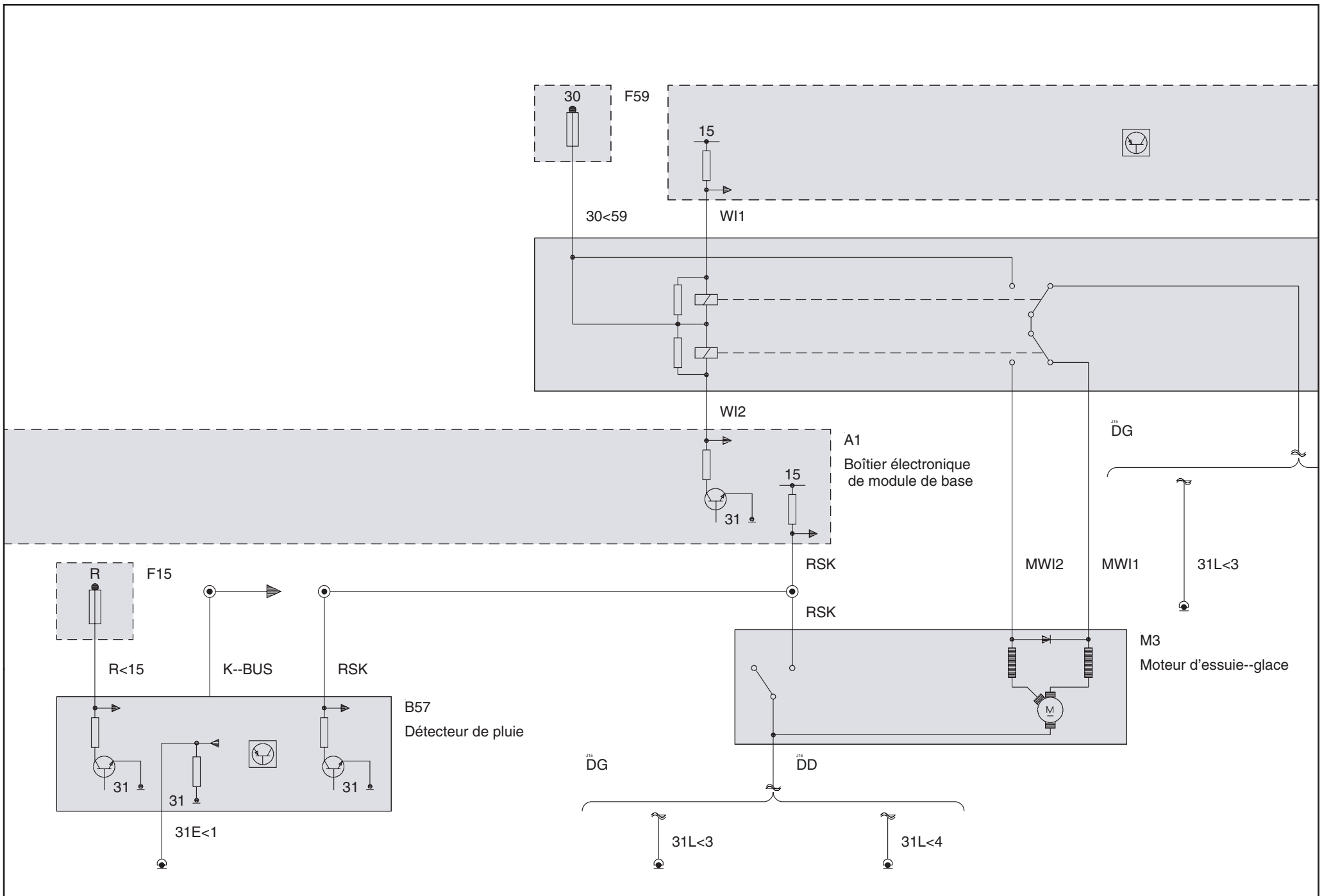

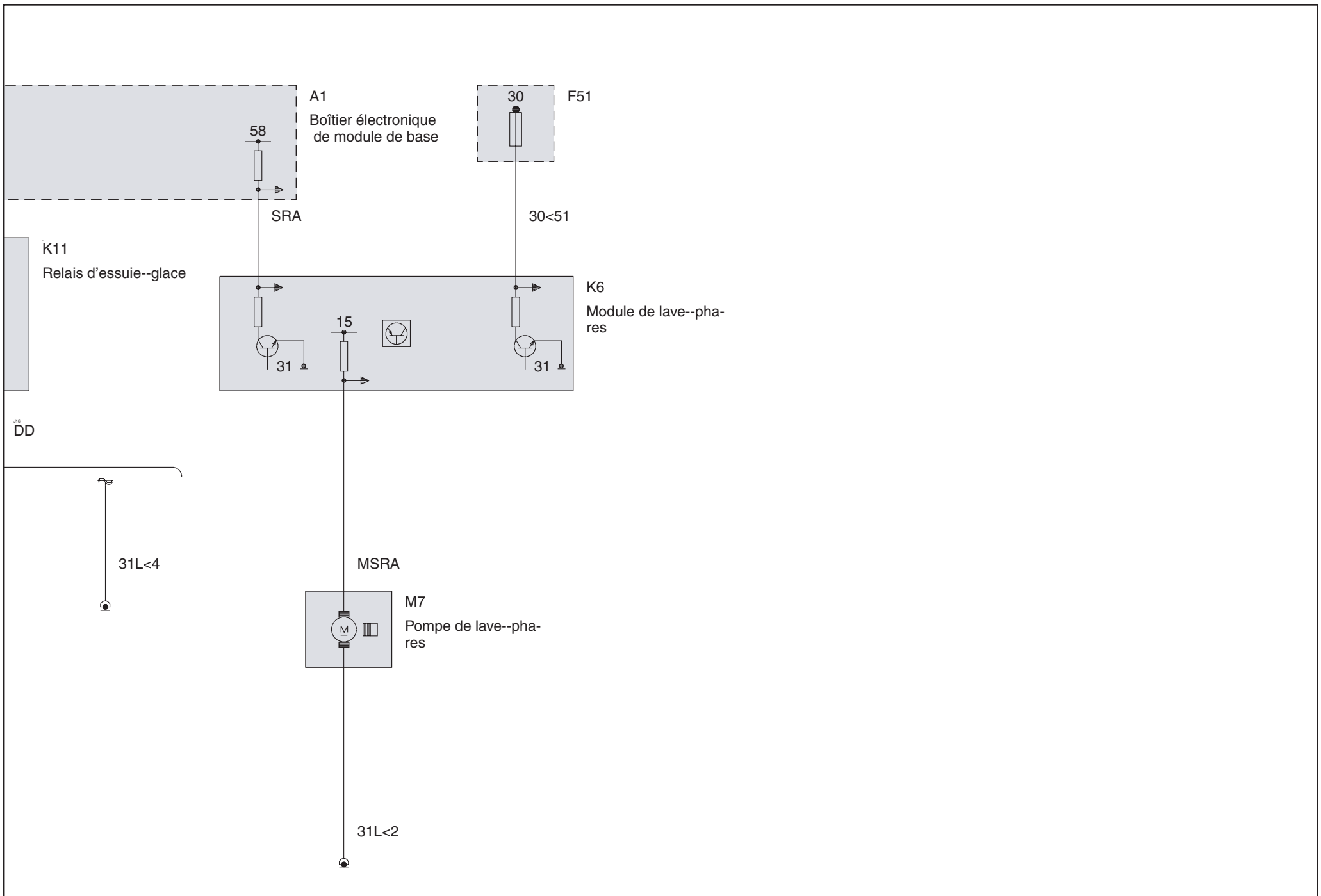

Fonctions essuie-glace/lave-glace (Touring)

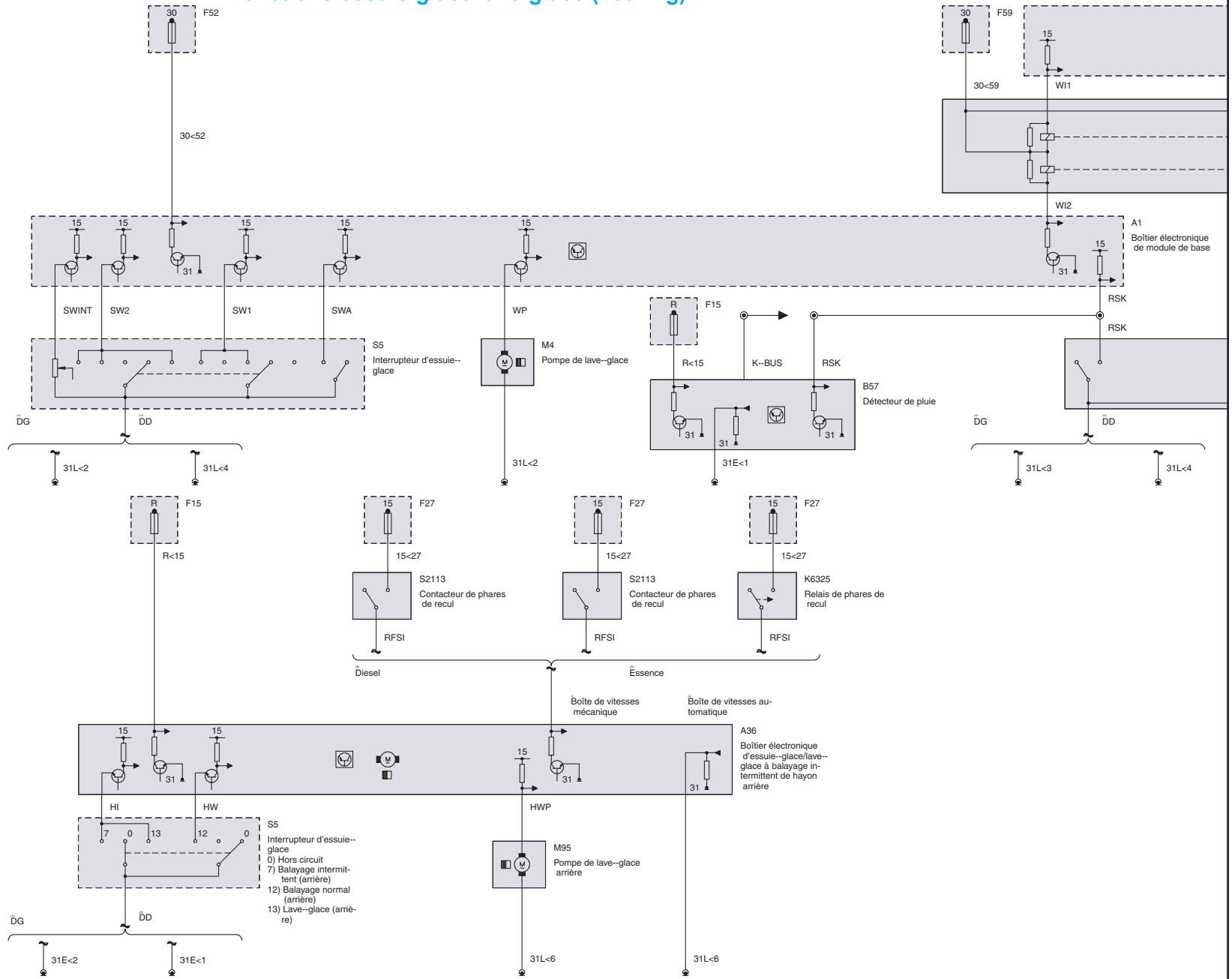

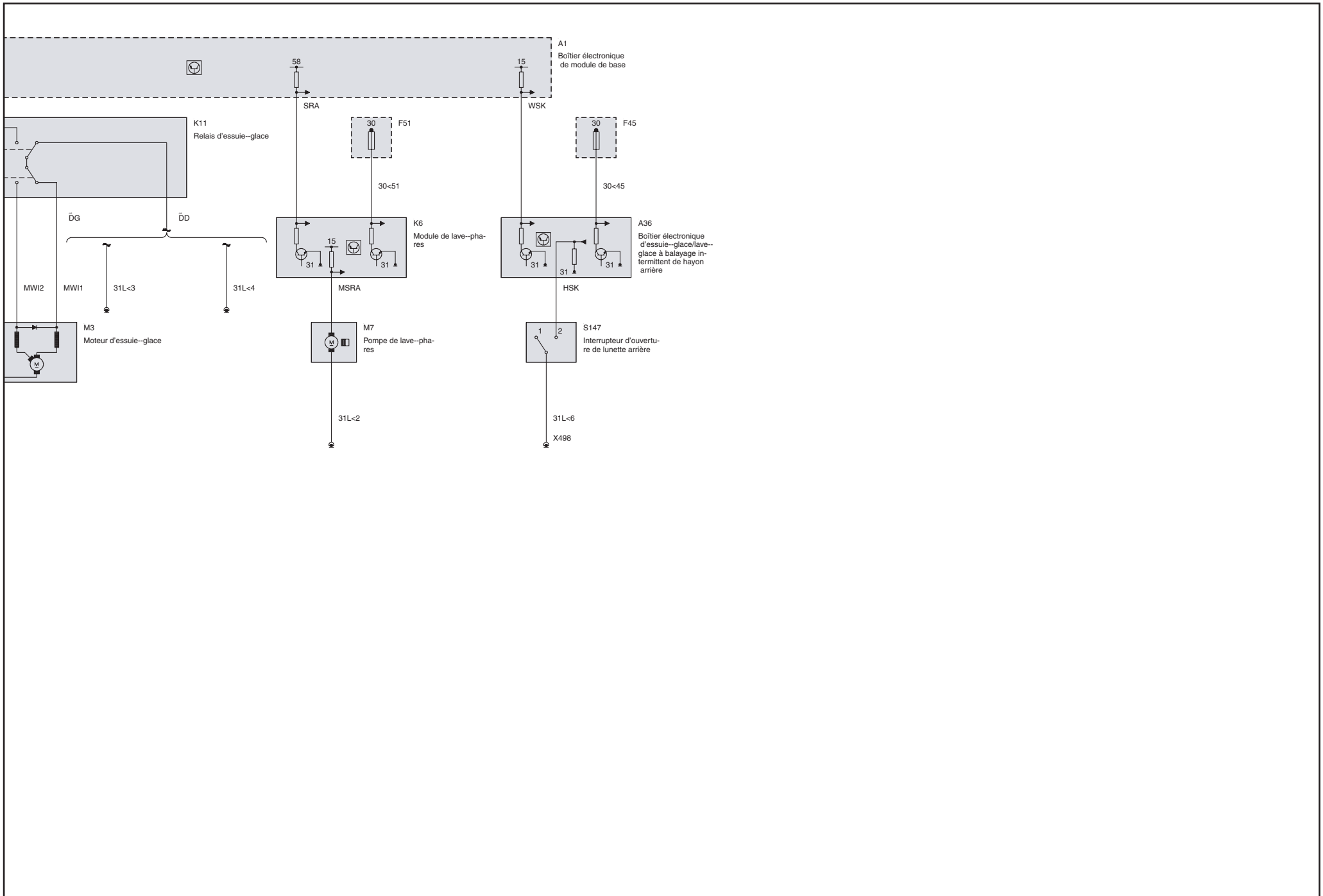

## Connecteur X10116

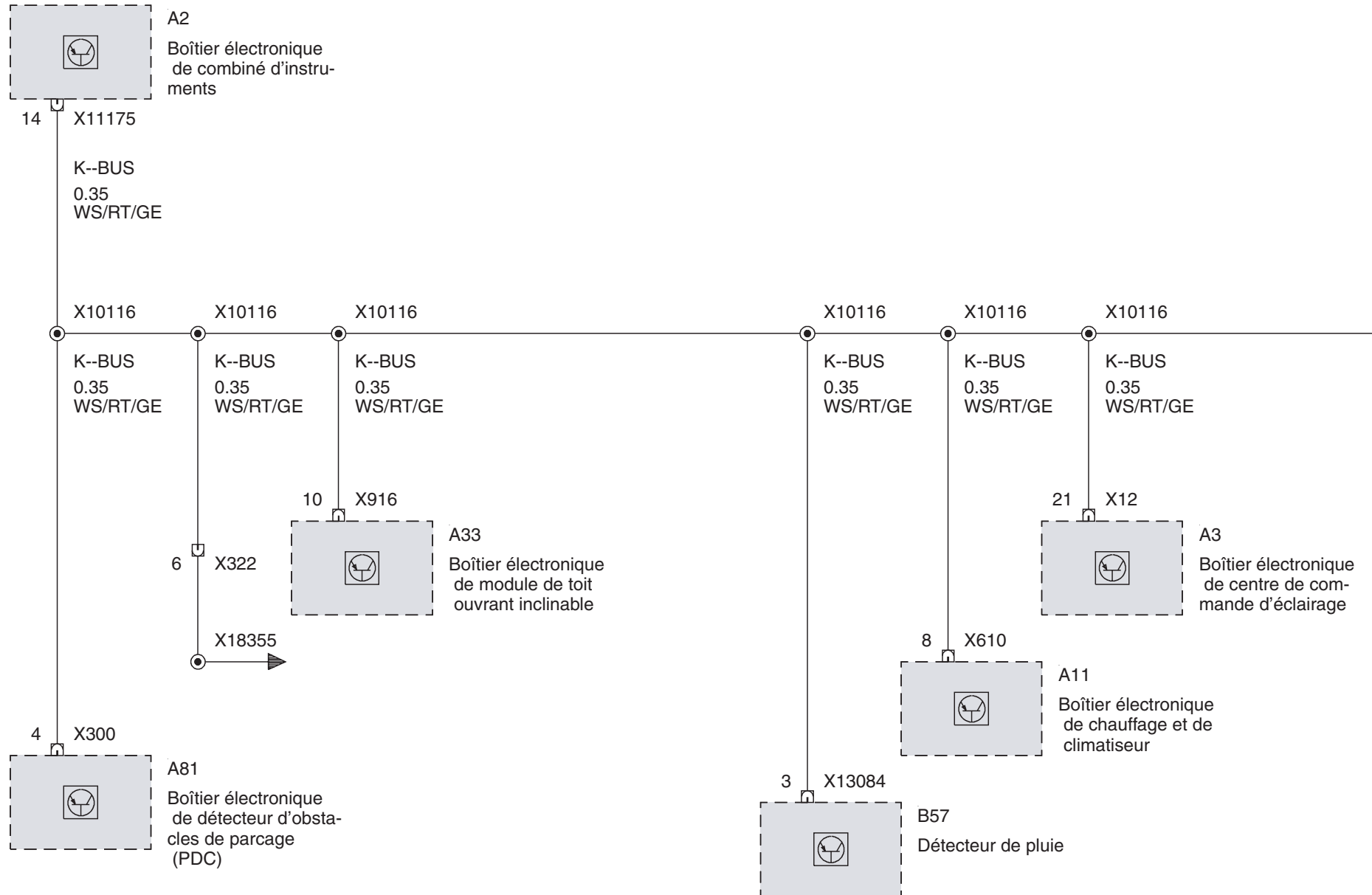



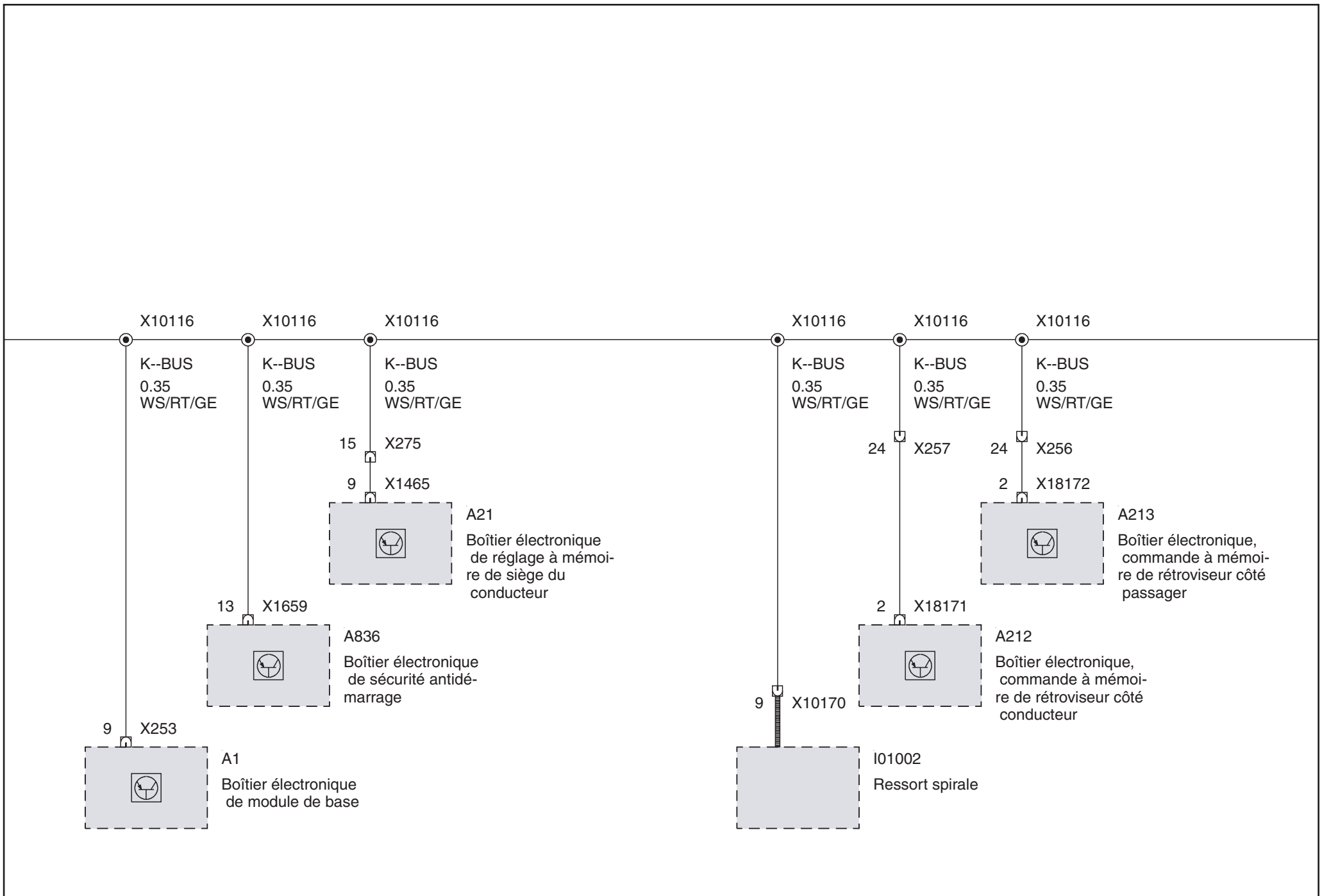

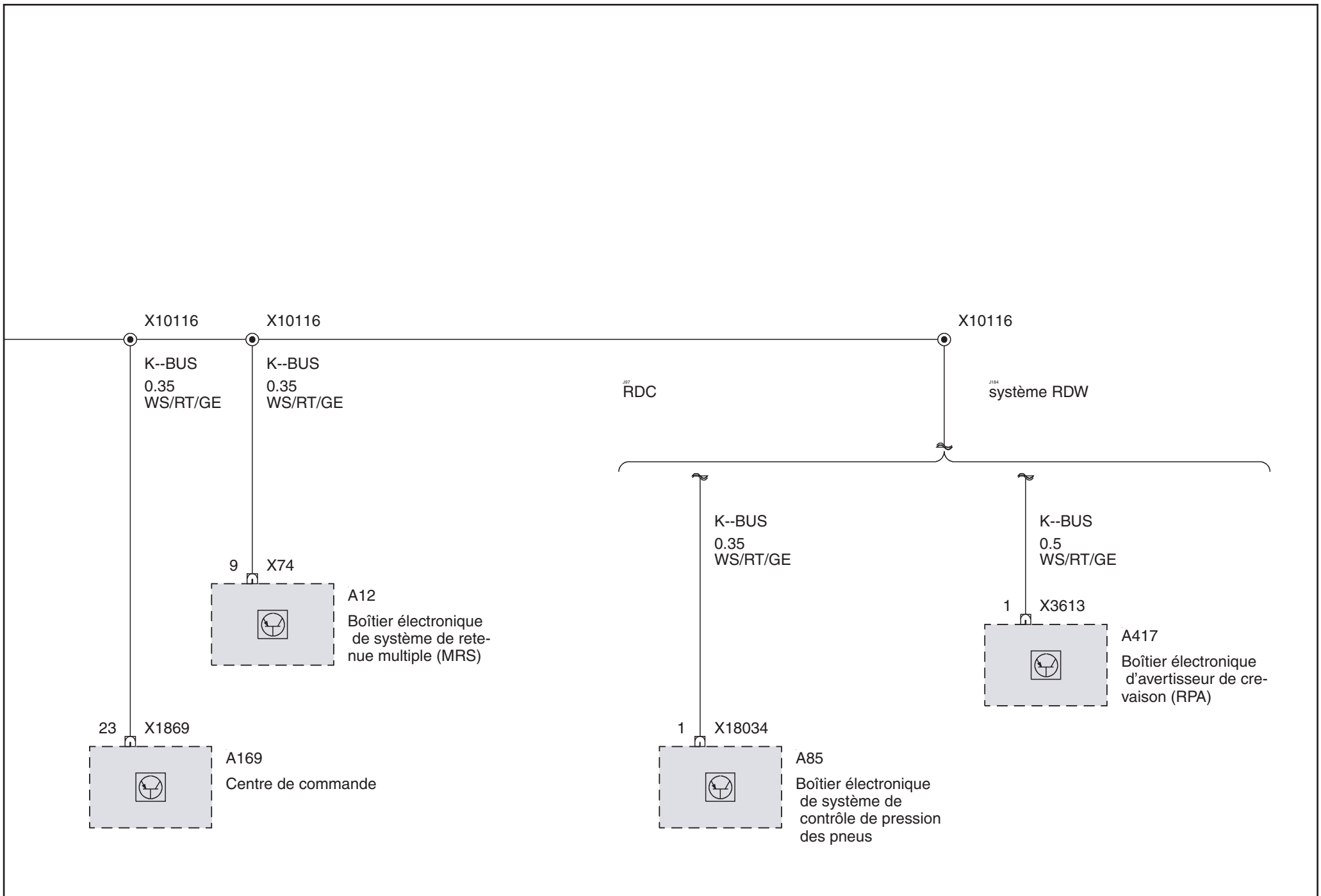

Alimentation

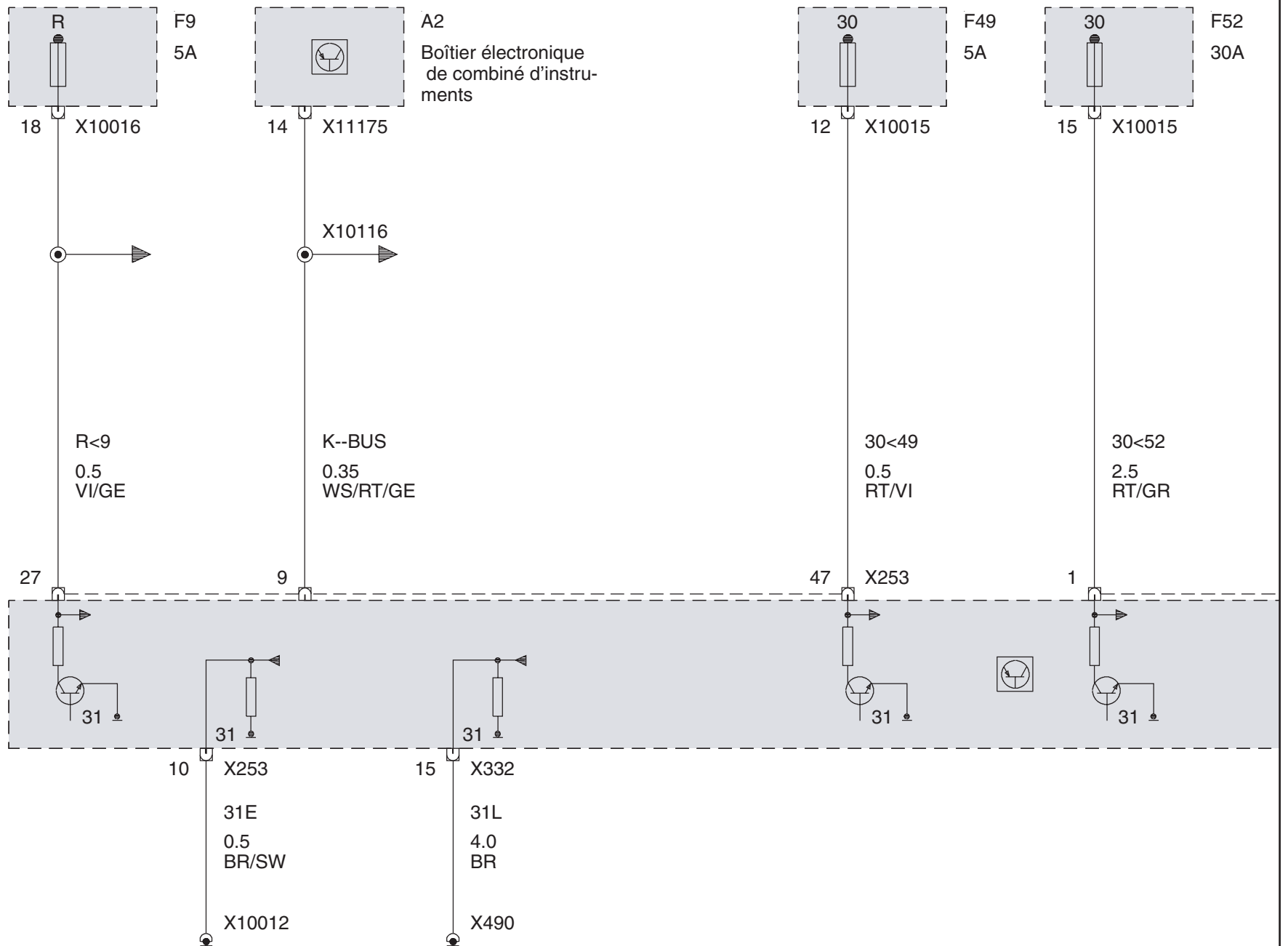

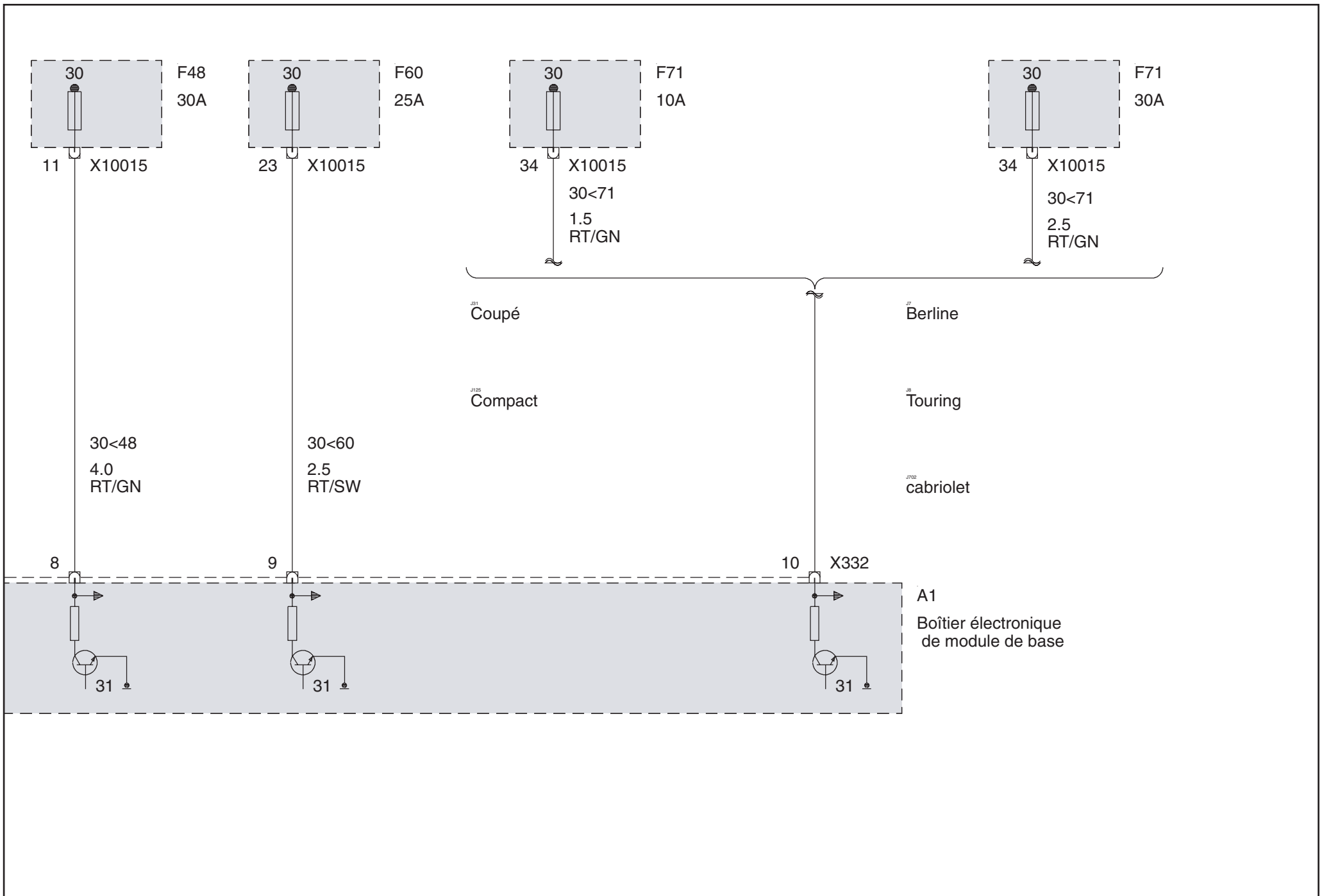

**Système d'essuie-glace**

Commande d'essuie-glace/lave-glace (jusqu'à 2003\_03) (Berline ou Compact ou Touring à partir de 2003\_03)

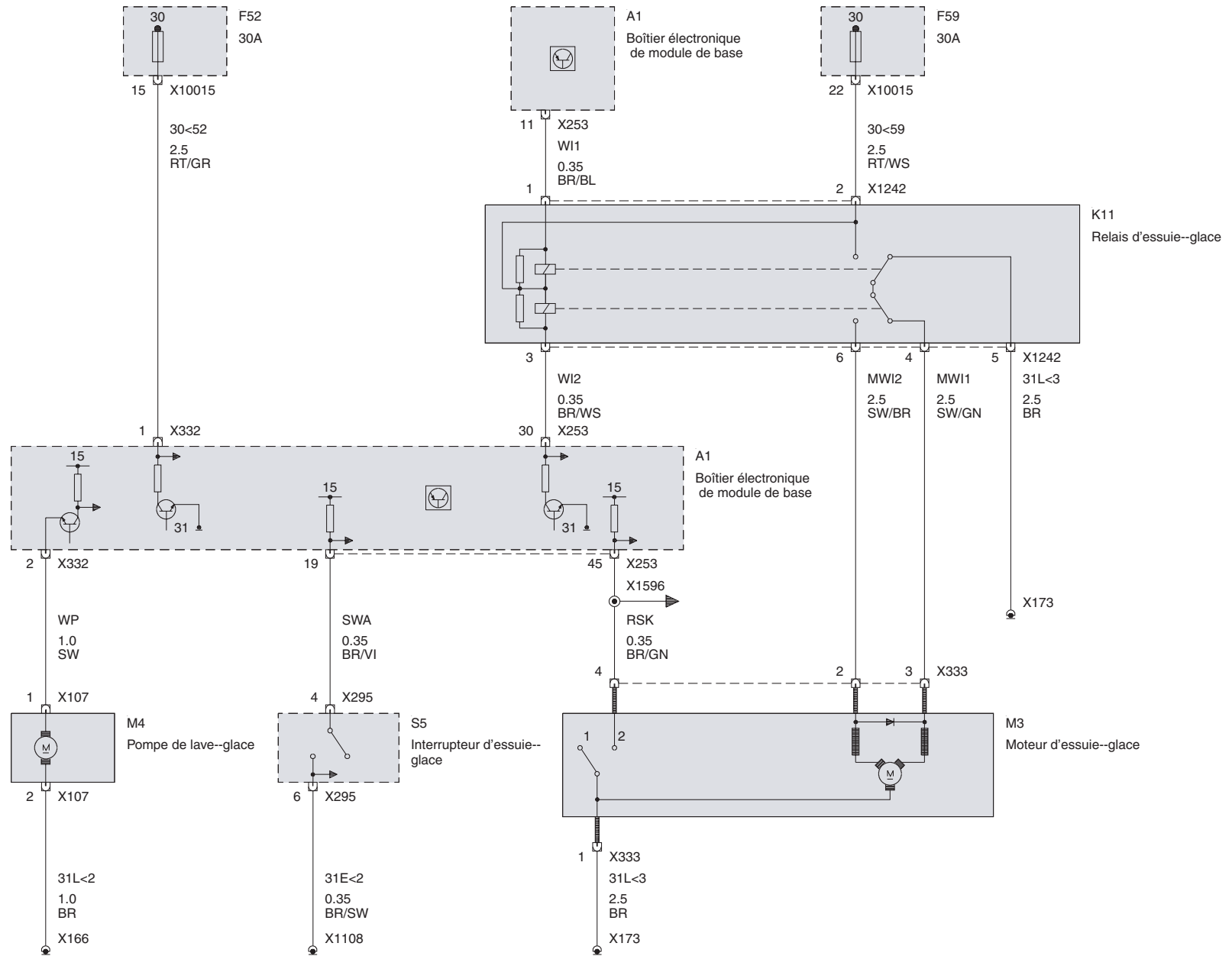

Commande d'essuie-glace/lave-glace (Coupé à partir de 2003\_03)

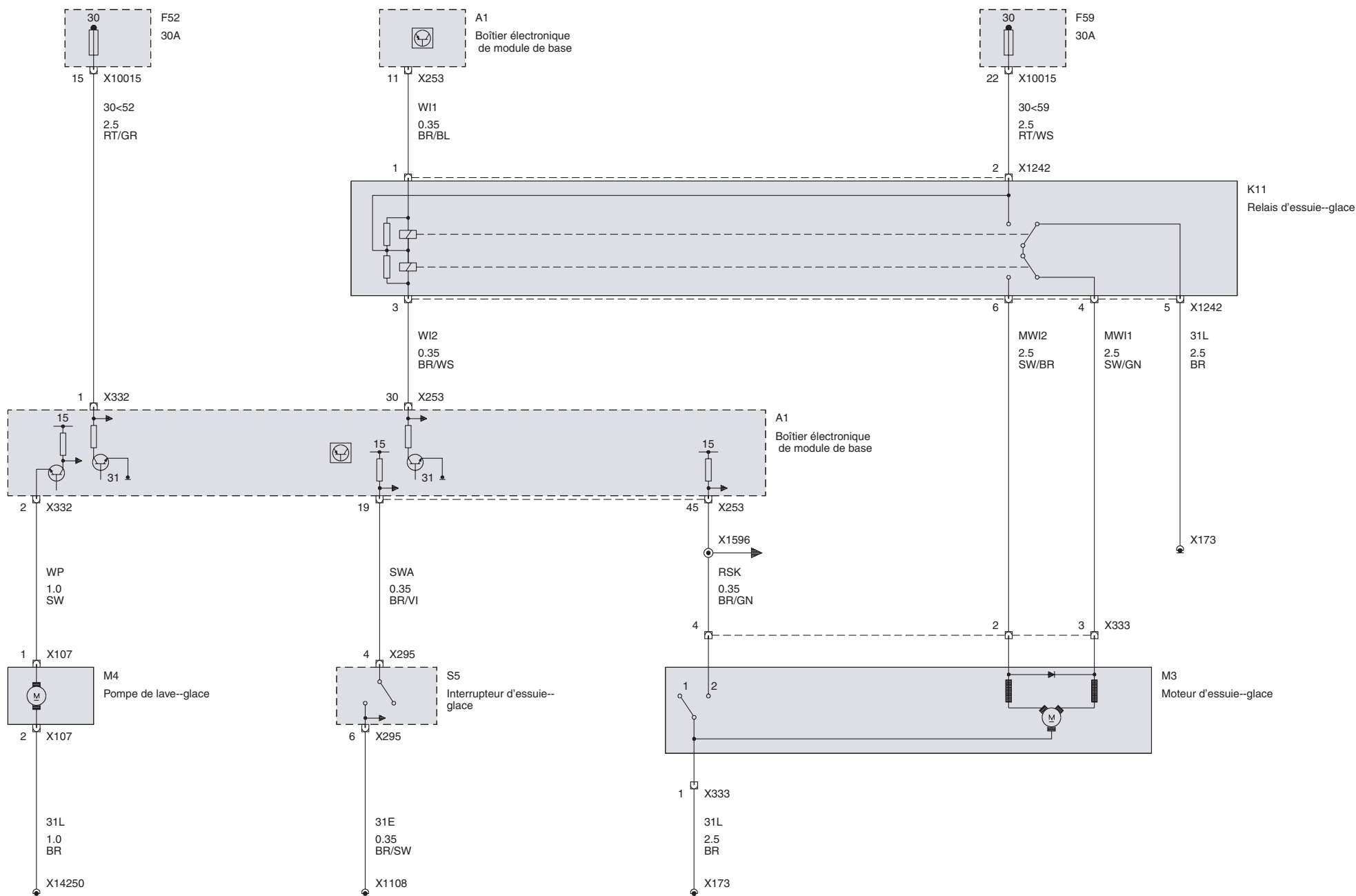

Commande d'essuie-glace/lave-glace de hayon arrière (Touring avec Essence)

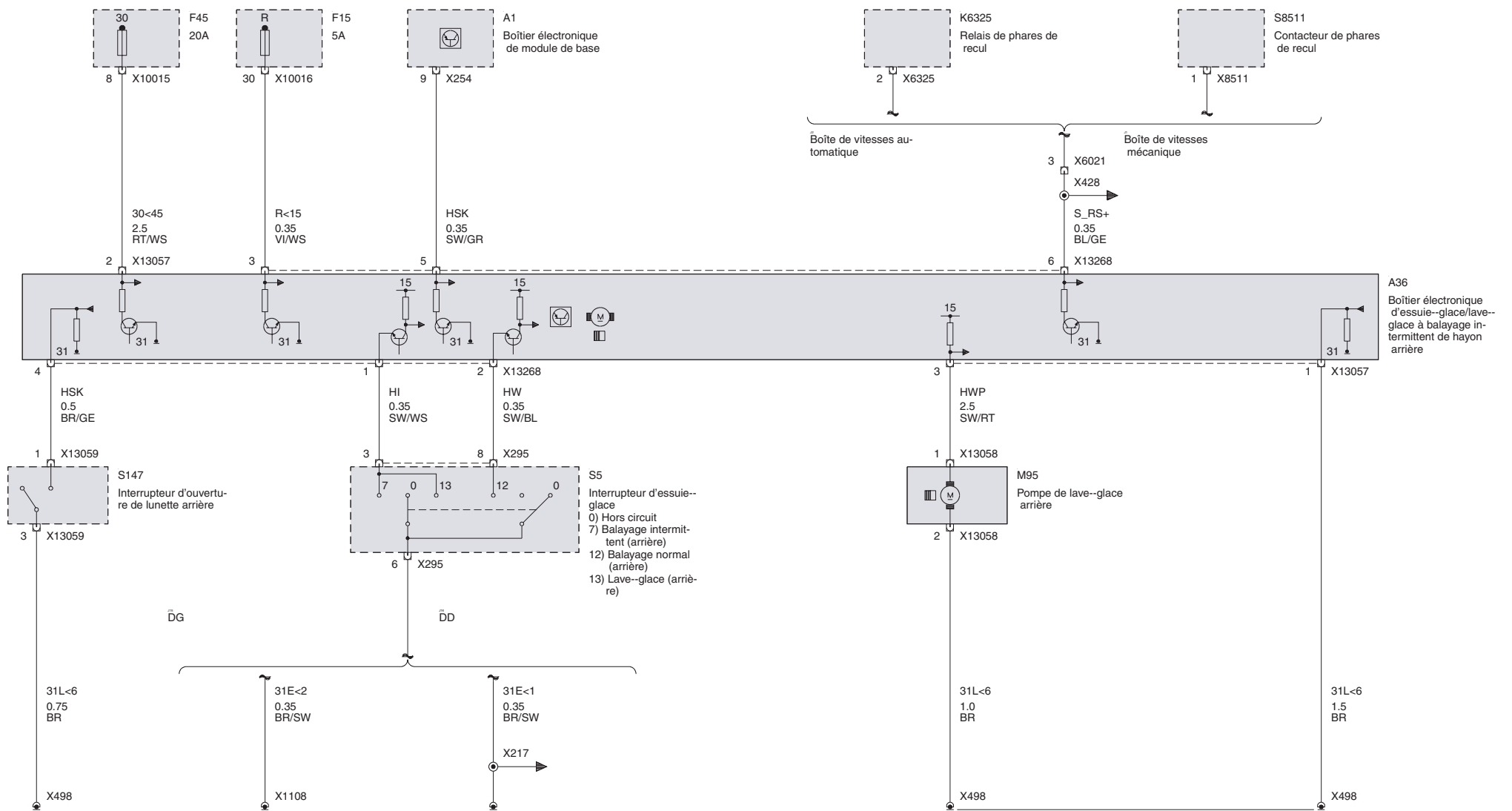

Commande d'essuie-glace/lave-glace de hayon arrière (Touring avec Diesel)

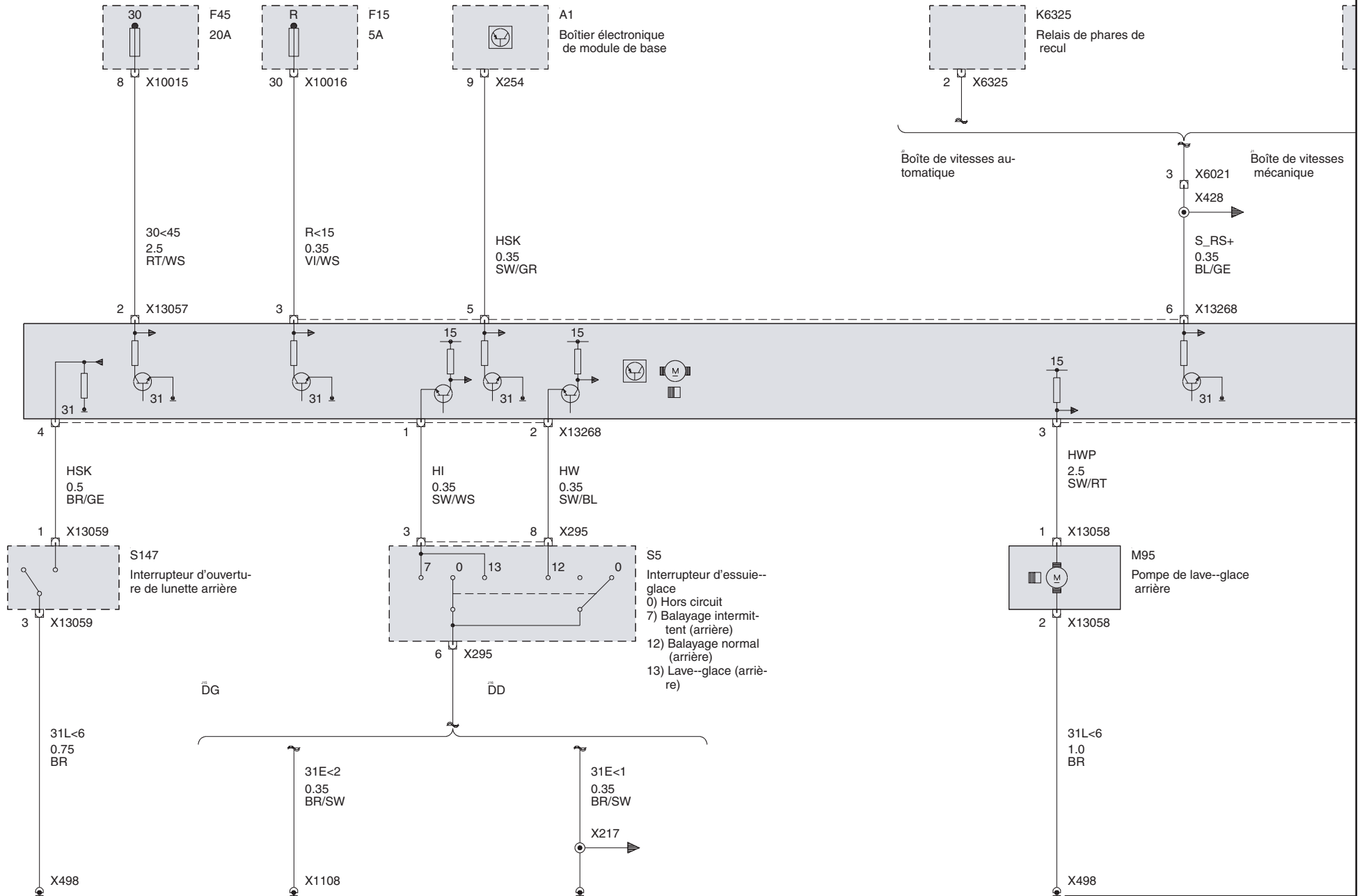





Commande d'essuie-glace/lave-glace de hayon arrière (Compact)

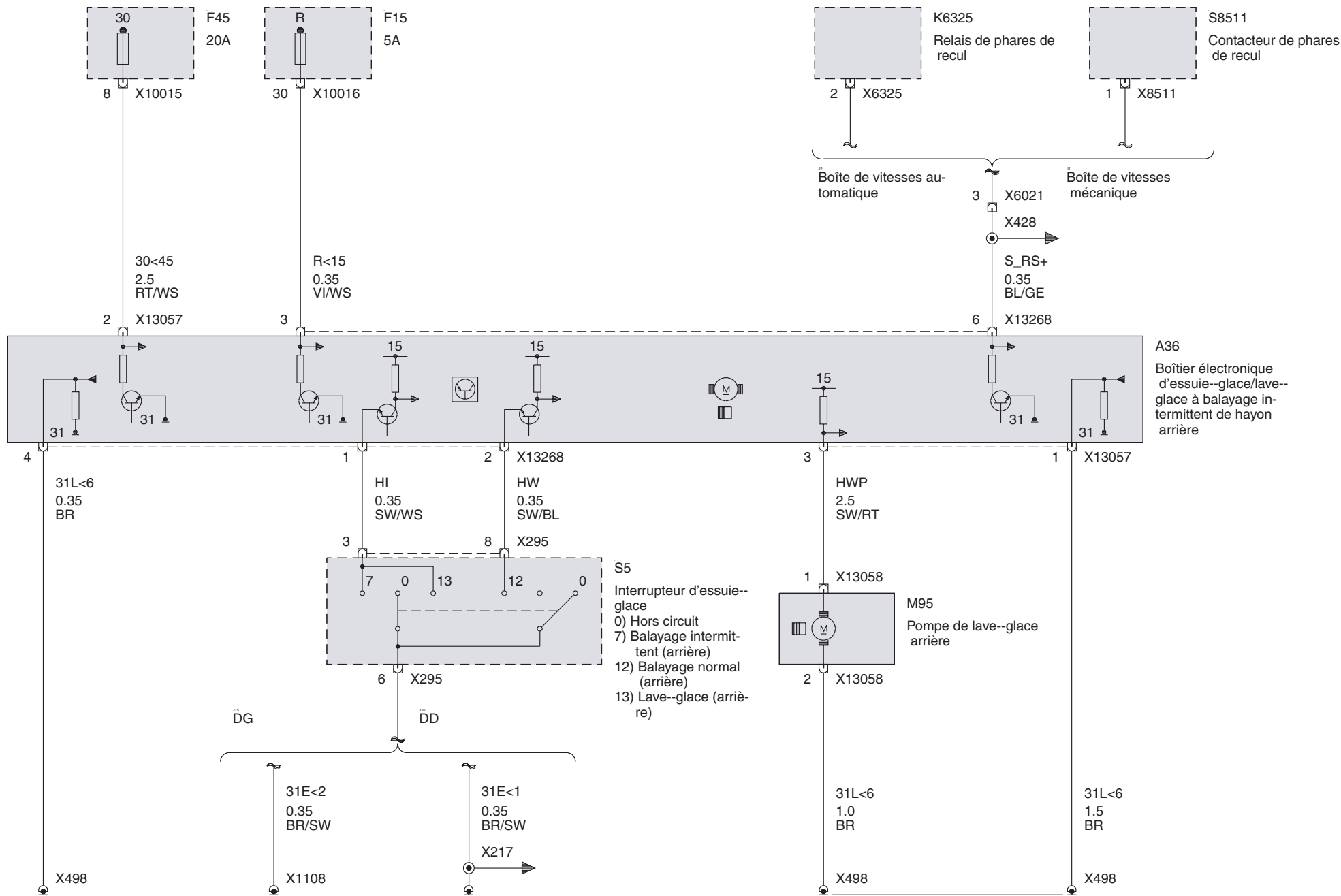





Lave-phares

Lave-phares (jusque 2003\_03)

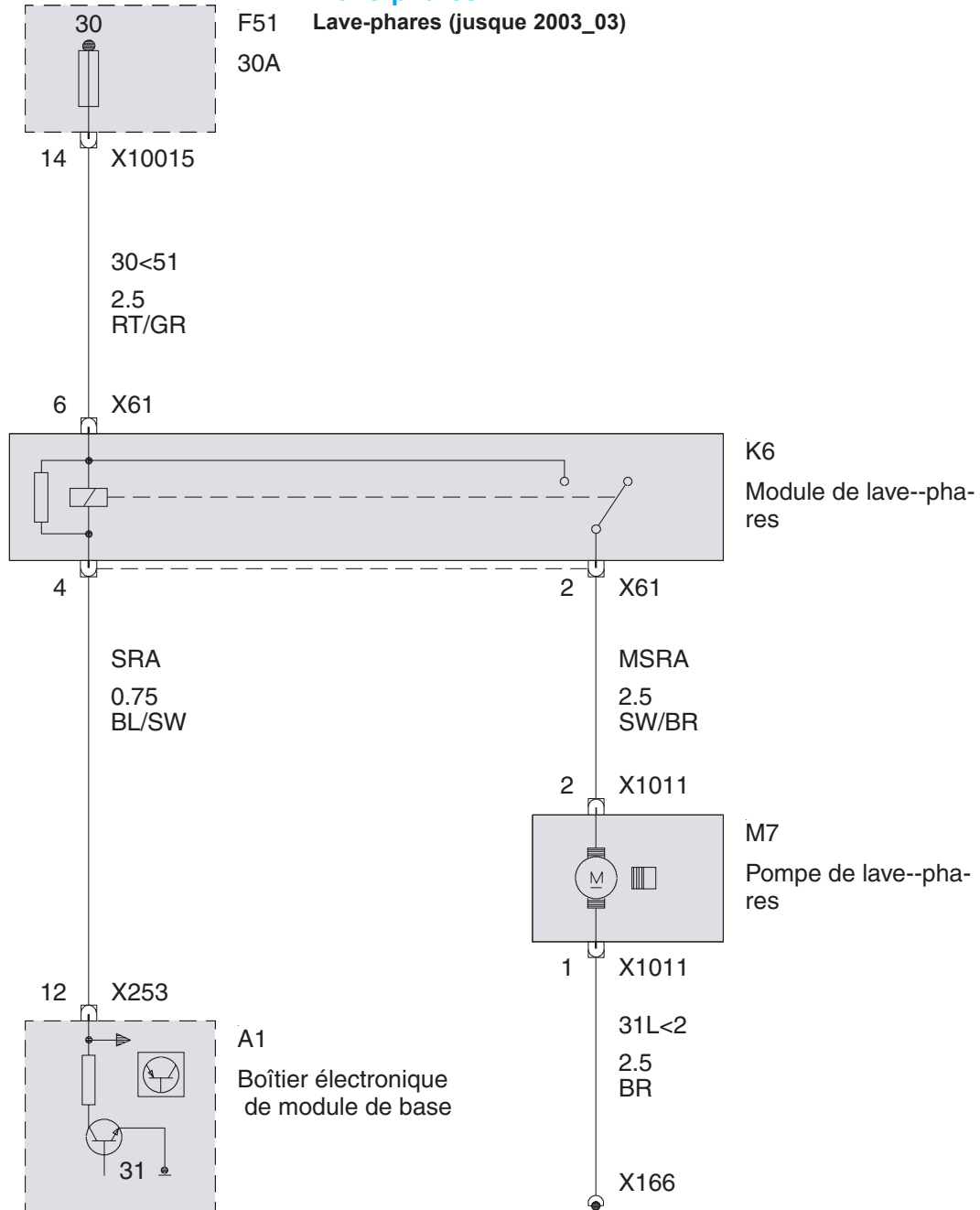

Lave-phares (à partir de 2003\_03)

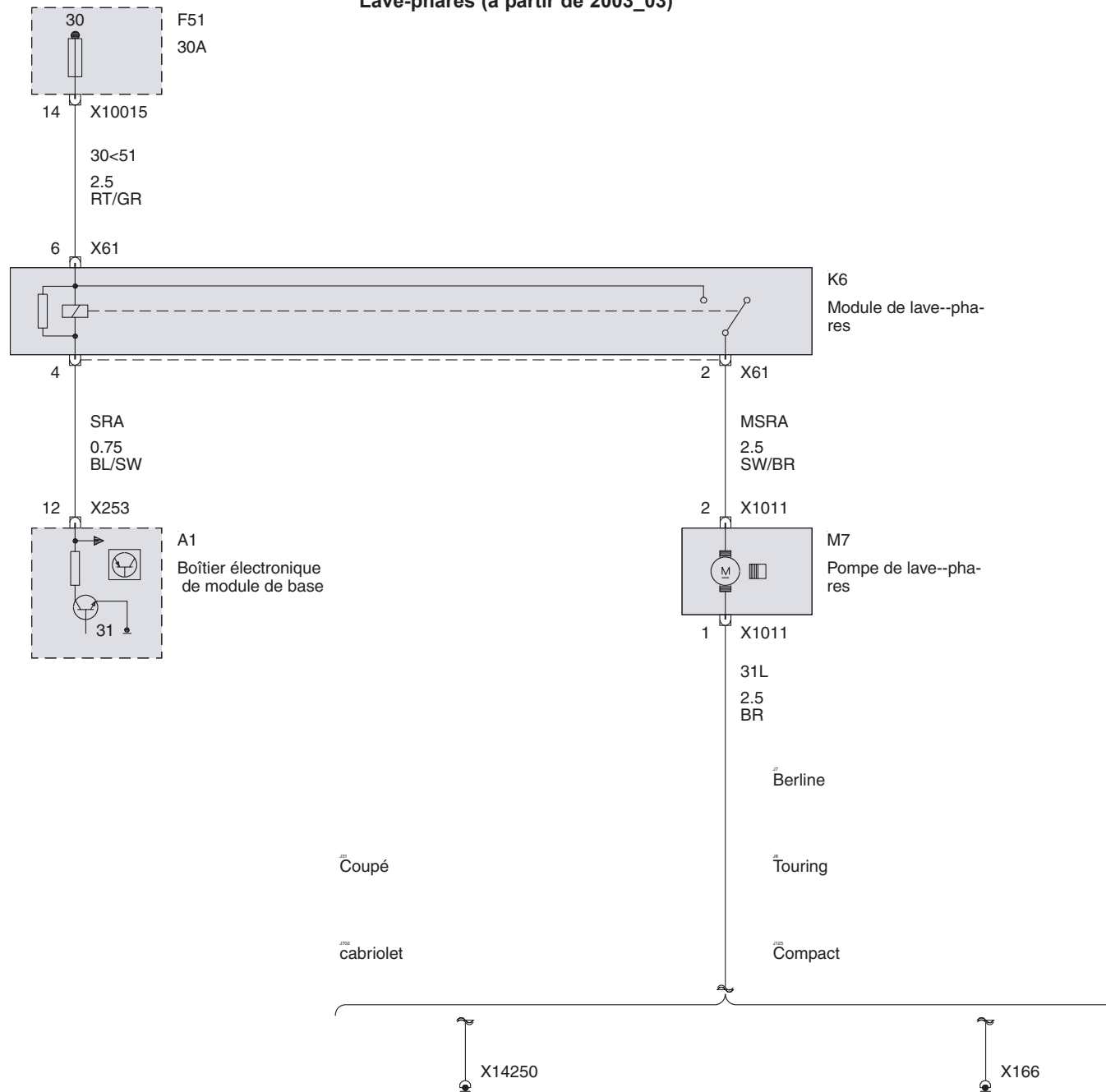

Capteur de pluie

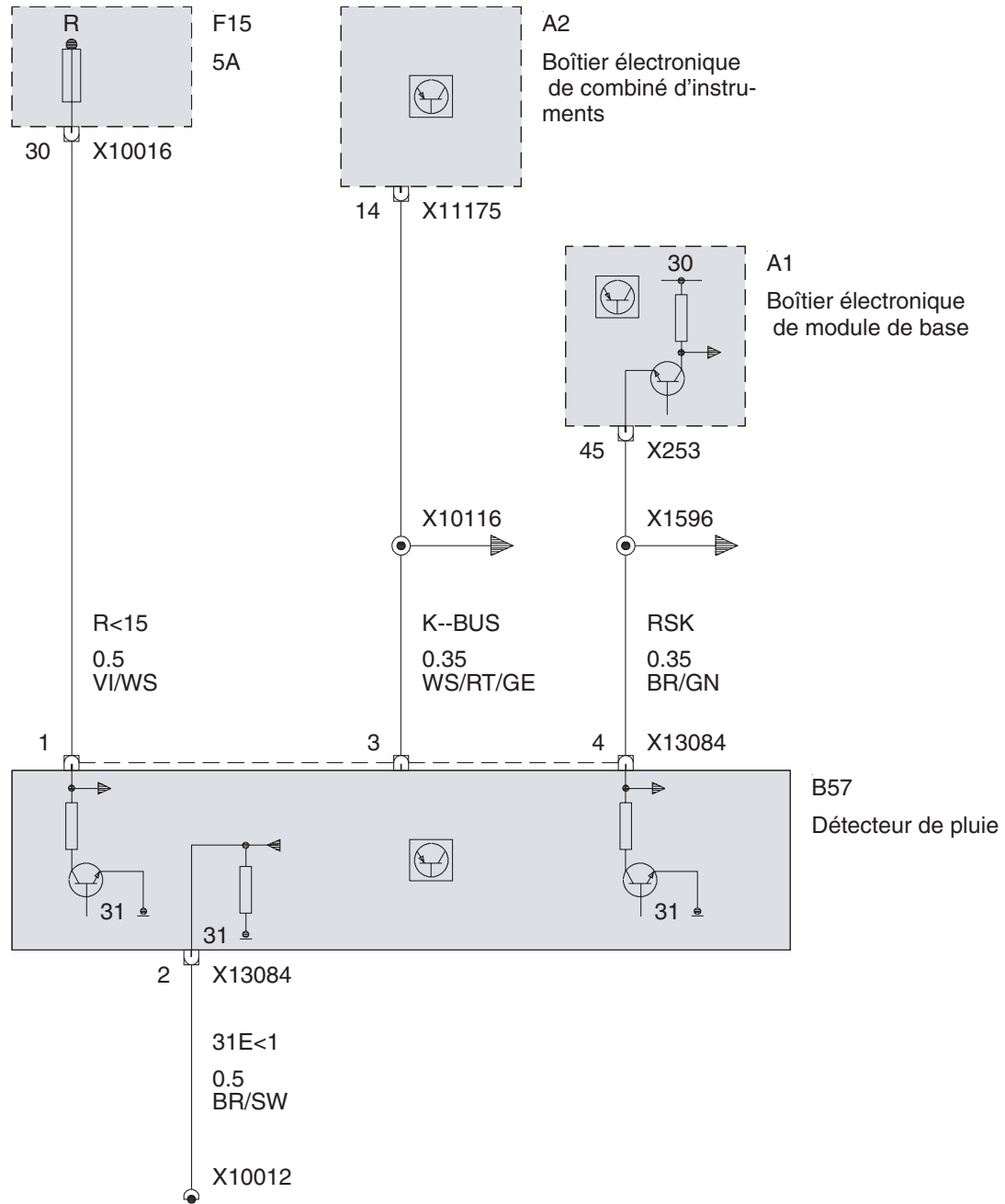

Manette essuie-glace

