

REPertoire

A JOUR LE: 01-09-90

NOM: MOUTH

TEL: 4319

FONCTIONS	PAGES	FONCTIONS	PAGES
DEMARREUR ALTERNATEUR-TEMOIN DE CHARGE	1/2	TEMPO-PLAFONN. -LECTEUR DE CARTE-PLIP-PARE SOLEIL ECLAIRE	25/3
DEMARREUR ALTERNATEUR-TEMOIN DE CHARGE XU*J* - XU5M	1/3	ECLAIRAGE VIDE POCHE	25/5
TEMOIN+BOUGIES PRECHAUFFAGE-ELECTROVANNE ARRET DE POMPE	1/5	BROUTEUR VEILLEUSES OUBLIEES	25/7
ALLUMAGE MOTEUR XU51C	2/1	LEVE VITRES ELECTRIQUES	26/1
ALLUMAGE MOTEUR XU*J* SAUF XU9JJAZ	2/2	LEVE VITRES ELECTRIQUES EN + PERMANENT	26/2
INJECTION MULTIPOINT XU*J*	2/3	CONDAMNATION CENTRALISEE 5 PORTES	27/1
INJECTION MULTIPOINT XU9JJAZ	2/4	CONDAMNATION CENTRALISEE 3 PORTES	27/2
INJECTION XU9JJAZ ALIMENTATION ALLUMAGE	2/5	CONDAMNATION CENTRALISEE 3 PORTES AVEC PLIP	27/3
TEMOIN AUTODIAGNOSTIC XU9JJAZ - XU5M	2/6	FEUX STOP	28/1
INJECTION MONOPOINT MOTEUR TU*M	2/7	FEUX DE RECU	29/1
INJECTION MONOPOINT MOTEUR TU*M ALLIMENTATION	2/8	INTERDICTION DE DEMARRAGE - XU51C XU*J1 (SF GF) ECL. CONSOLE	29/2
TEMOIN AUTODIAGNOSTIC TU*M	2/9	INTERDICTION DE DEMARRAGE - XU51C XU*J1 GF ECL. CONSOLE	29/3
ALLUMAGE MOTEUR TU	2/11	INTERDICTION DE DEMARRAGE - XU5M GF ECL. CONSOLE	29/4
INJECTION MONOPOINT XU5M	2/15	INTERDICTION DE DEMARRAGE - XU5M (SF GF) ECL. CONSOLE	29/5
INJECTION MONOPOINT XU5M - ALLUMAGE ALIMENTATION	2/16	INTERDICTION DE DEMARRAGE - XU9JJAZ (SF GF) ECL. CONSOLE	29/6
MOTOVENTILATEUR 1 VITESSE	3/1	FEU AR BROUILLARD	30/1
MOTOVENTILATEUR 2 VITESSES	3/2	FEU AR BROUILLARD DIRECTION DROITE	30/2
GROUPE MOTOVENTILATEUR DIESEL - XU*J1	3/3	ECLAIREURS PLAQUE MATRICULATION	31/1
GROUPE MOTOVENTILATEUR REFRI SAUF XU9JJAZ	3/4	JAUGE CARBURANT(3 CADRANS)	32/1
GROUPE MOTOVENTILATEUR REFRI XU9JJAZ XU5M	3/5	JAUGE CARBURANT(4-6 CADRANS)	32/2
GROUPE MOTOVENTILATEUR RALLYE	3/6	LUNETTE AR CHAUFFANTE RETRO CHAUFFANT	33/1
GROUPE MOTOVENTILATEUR REFRI TU*M	3/7	ESSUIE VITRE AR	34/1
TEMOIN STARTER	4/1	ALIMENTATION ATTACHE REMORQUE	35/1
COMPTE TOURS MOTEUR XU	5/1	ECLAIREUR COFFRE	36/1
COMPTE TOURS MOTEUR TU	5/2	LAVE PROJECTEURS	37/1
TEMOIN NIVEAU EAU MOTEUR XU99 EGR - XUD7T	6/2	SIEGES CHAUFFANTS-POMPE ADDITIONNELLE	38/1
TEMOINS: STOP-PRESSION HUILE-TEMP. EAU-NIVEAU EAU(6 CADRANS)	7/1	FEUX DIURNES ESSENCE (SF BVA)	39/1
TEMOINS: STOP-PRESSION HUILE-TEMP. EAU-NIVEAU EAU(4 CADRANS)	7/2	FEUX DIURNES DIESEL	39/2
TEMOINS: STOP-PRESSION HUILE-TEMP. EAU-NIVEAU EAU(3 CADRANS)	7/3	FEUX DIURNES BVA (SF XU5M BVA)	39/3
POMPE IMMERGEE-TEMOIN HUILE XU51C	7/5	FEUX DIURNES XU5M BVA	39/4
TEMOIN FREIN A MAIN -NIV.LIQU. USURE PLAQUETTES (3 CADRANS)	8/1	CAPOTE ELECTRIQUE	40/2
TEMOIN FREIN A MAIN -NIV.LIQU. USURE PLAQUETTES (4 CADRANS)	9/1	ANTIPOLLUTION DIESEL XU99EGR	41/4
TEMOIN BRAKE AUSTRALIE	9/2	REFRIGERATION	43/1
SONDE TEMPERATURE CATALYSEUR GT1 JAPON	9/6	ORDINATEUR DE BORD-DOUBLES COMMANDES(AUTO-ECOLE)	44/1
DETECTEUR PRESENCE EAU DANS GAS OIL	10/1	FEUX DIM DIPS	45/1
RECEPTEUR COMBINE 6 CADRANS	11/1	ANTIBLOCAGE ROUES -ADDONIX 4-2	46/1
AVERTISSEUR	12/1	TEMOIN AUTODIAGNOST. ANTIBLOCAGE ROUES	46/2
AVERTISSEUR A COMPRESSION	12/2	GENDARMERIE GT	46/10
FEUX DE POSITION DIRECTION DROITE	13/2	SURETE NATIONALE NON BANALISEE	46/11
FEUX DE POSITION	13/3	GENDARMERIE GL	46/12
FEUX DE CROISEMENT	14/1	FONCTIONS PROTEGEES PAR FUSIBLES	47/1
FEUX DE ROUTE(3 CADRANS)	15/1	BOITIER INTERCONNEXION	48/1
FEUX DE ROUTE-LONGUES PORTEES(4-6 CADRANS)	15/2	CONNECTEURS SUR BOITIER INTERCONNEXION	49/1
CLIGNOTANTS-REPETITEURS	16/1	CONNECTEURS SUR BOITIER INTERCONNEXION	49/2
SIGNAL DANGER	17/1	CONNECTEURS SUR BOITIER INTERCONNEXION	49/3
ESSUIE VITRE AV NON TEMPORISE	18/1	INTERCONNEXIONS SUR GARNITURE ALUVENT G	50/1
ESSUIE VITRE AV TEMPORISE	18/2	CONNECTEURS SUR COMBINE 4/6 CADRANS	51/1
ECLAIRAGE FACADE CLIMATISEUR et COMBINE DIRECTION DROITE	19/1	CONNECTEURS SUR COMBINE 3 CADRANS	51/2
ECLAIRAGE FACADE CLIMATISEUR et COMBINE	19/2	CONNECTEURS + ET INTERCONNEXIONS	52/1
MONTRE AIGUILLES	20/1	CONNECTEURS + ET INTERCONNEXIONS	52/2
MONTRE DIGITALE	20/2	NUMEROTAT. APPAREILS ET ABBREVIATIONS	53/1
CLIMATISEUR	21/1	IMPLANTATION DES PLUS	54/1
ALLUME CIGARE	22/1	IMPLANTATION DES MASSES	54/2
ALIMENTATION AUTO RADIO-HAUT PARLEURS	24/1	NOMENCLATURES DES FILS	56/1
PLAFONNIER-LECTEUR DE CARTE	25/1	NOMENCLATURES DES FILS	56/2
PLAFONNIER-LECTEUR DE CARTE-PLIP	25/2	NOMENCLATURES DES FILS	56/3
		NOMENCLATURES DES FILS	56/4

TYPES CONCERNES :
 - XU*J*
 - XU5M

DEMARREUR ALTERN. TEMOIN DE CHARGE

1/3

A JOUR LE: 01-09-90

NOM: MOUTH

TEL: 4319

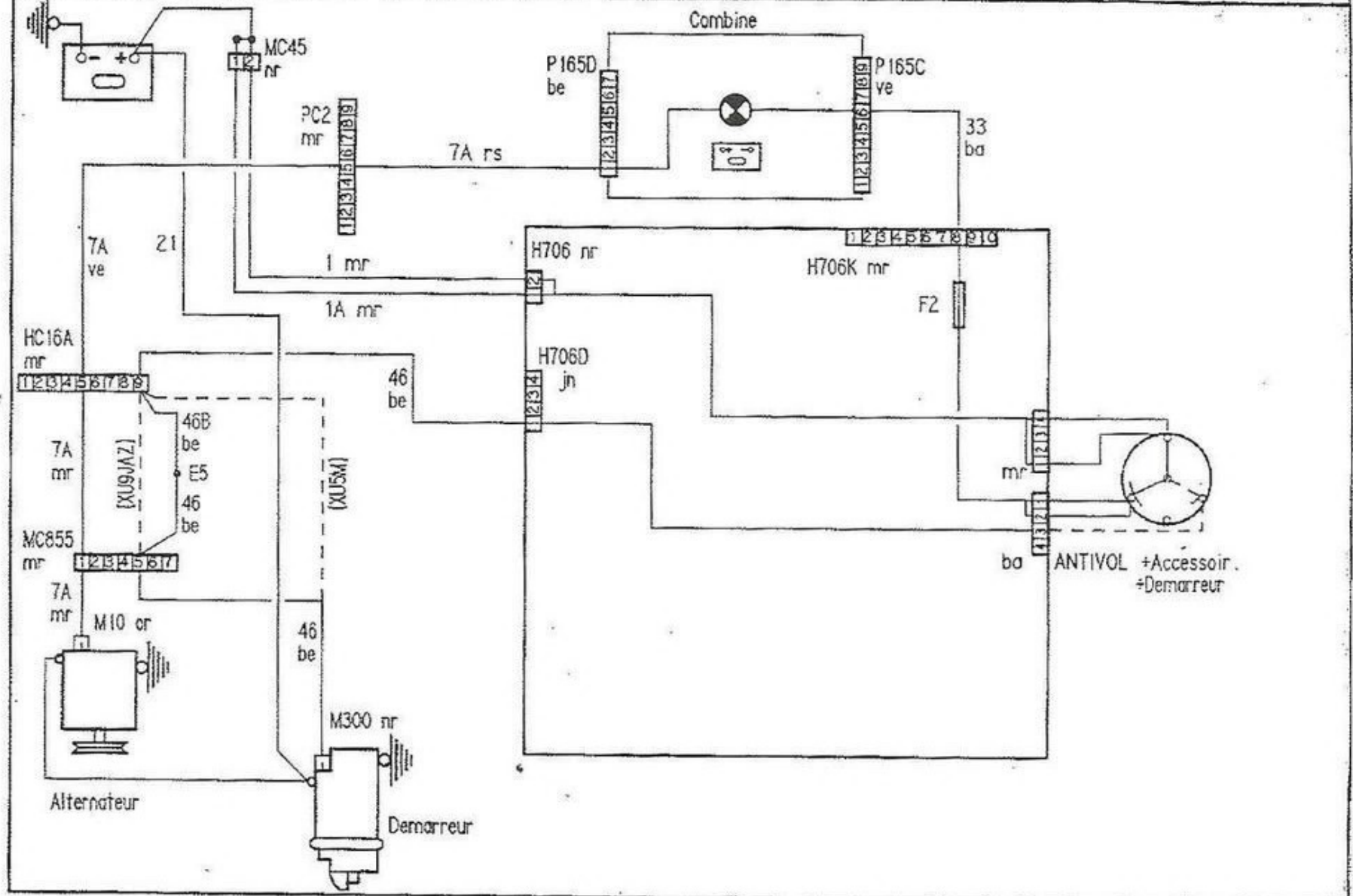

TYPE CONCERNE:
-205DSL

ELECTROVANNE TEM. +BOUGIES PRECHA

1/5

A JOUR LE: 01-09-90

NOM: MOUTH

TEL: 4319

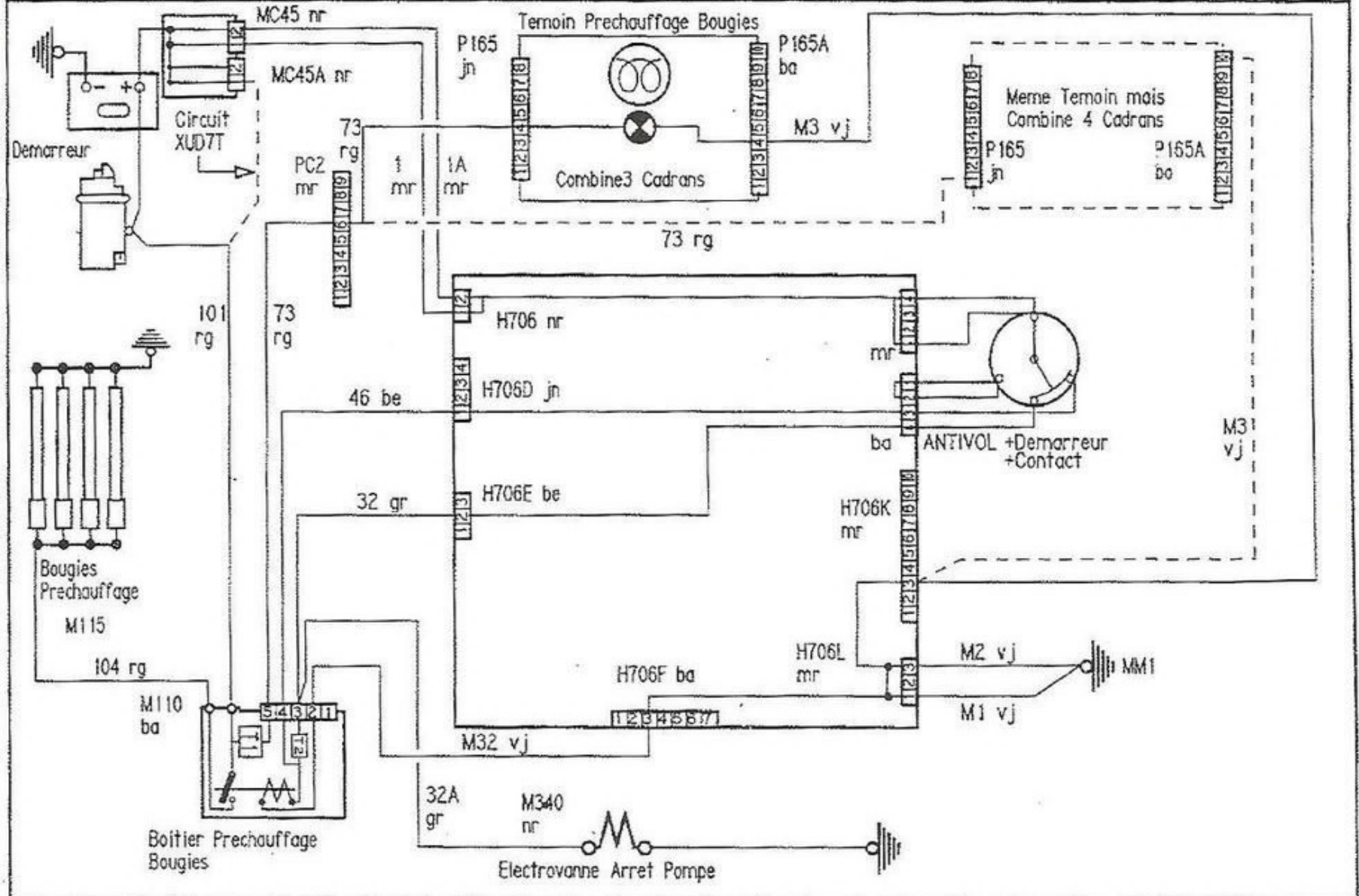

ALLUMAGE MOTEUR XU51C

2/1

DATE: 01-07-90

NOM: MOUTH

TEL: 4319

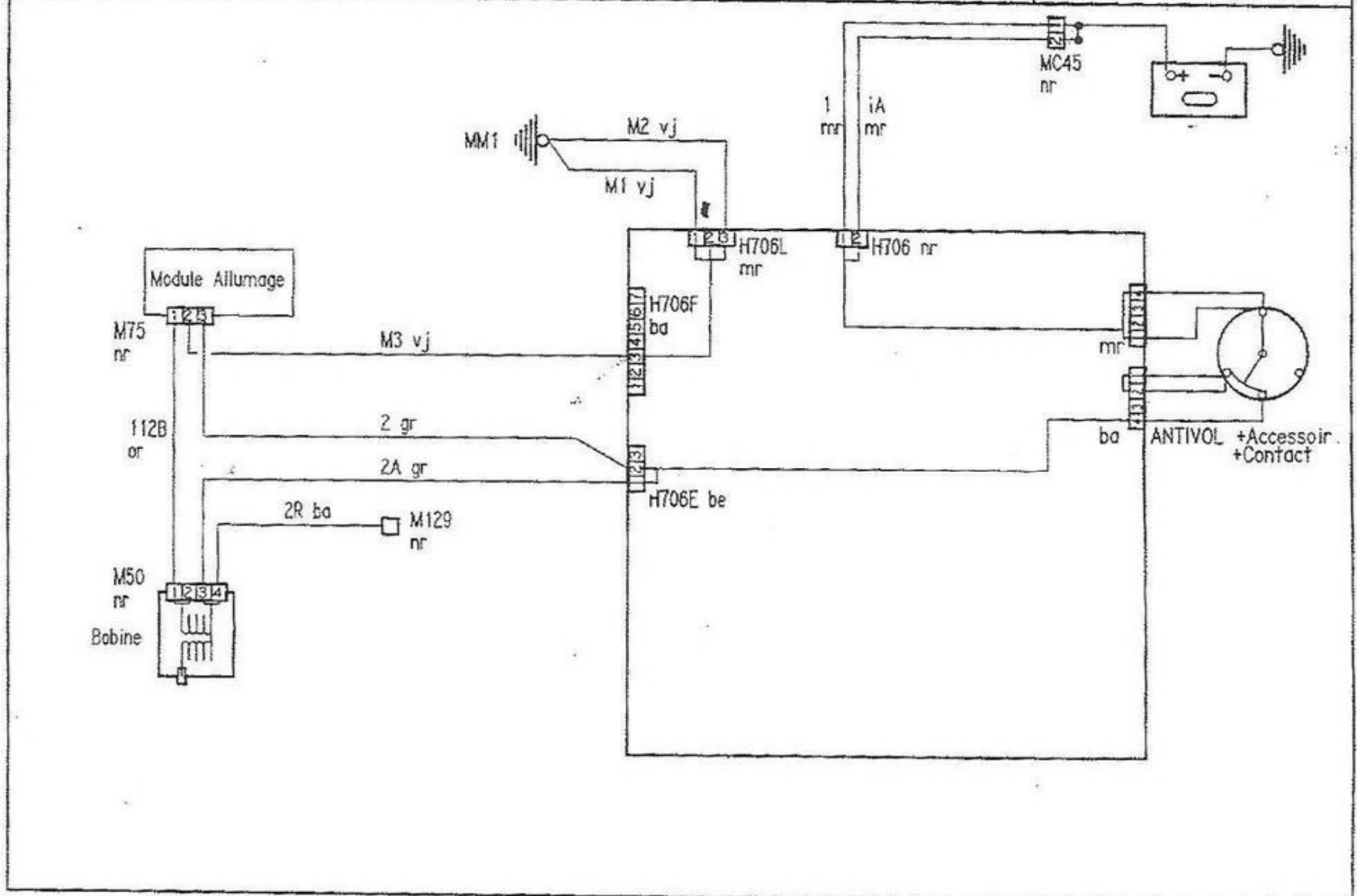

Allumage TT XU*J* SAUF XU9J JAZ

ALLUMAGE
MOTEUR XU*J*

2
2

A JOUR LE: 01-09-90

NOM: MOUTH

TEL: 4319

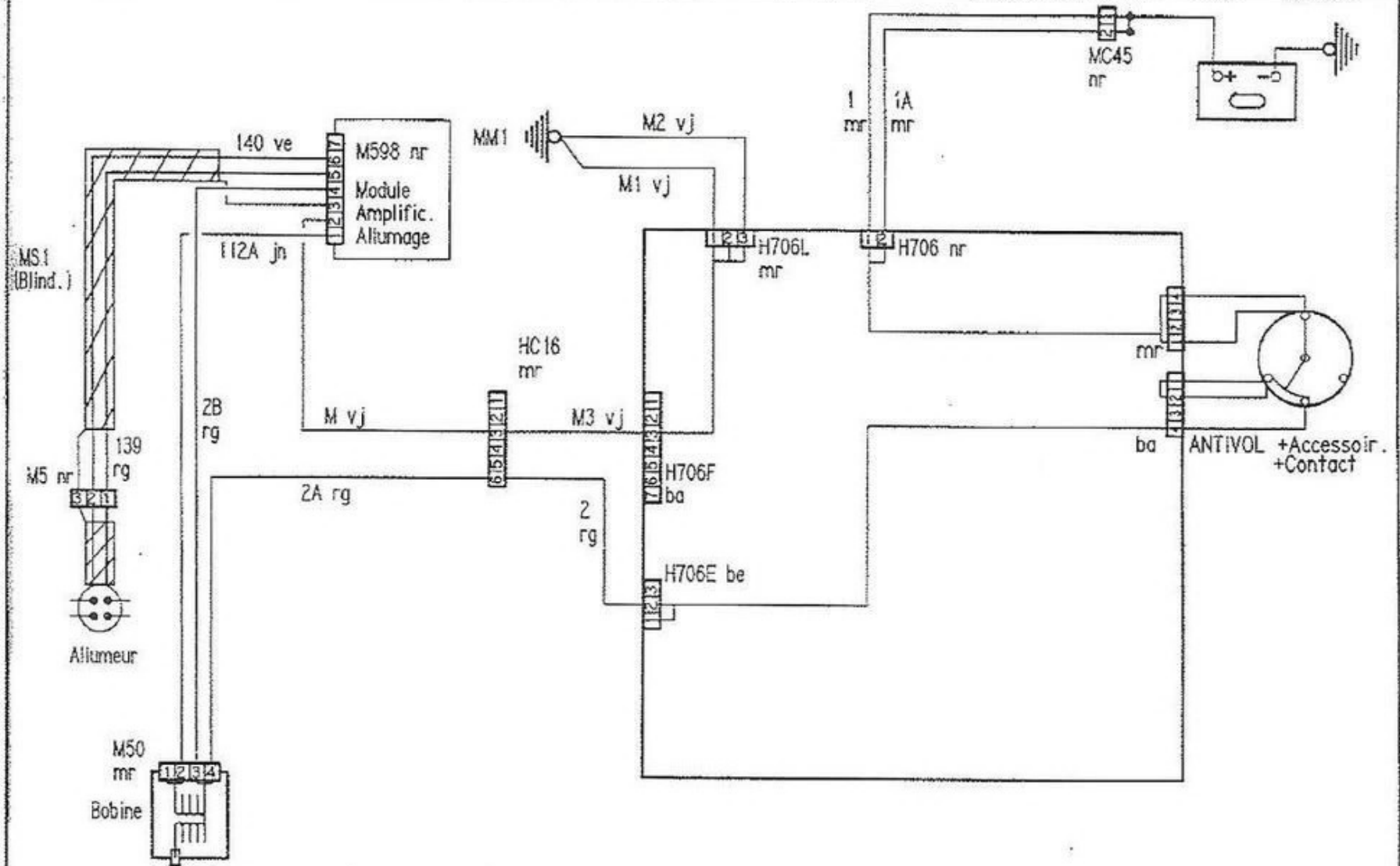

EN/POINTILLES : spécifique moteur XU9J1

NOTA : Rechauffeur Vapeur Huile
- GRAND FROID

Connecteur CALCULATEUR
25 Voies P58 nr

1 2 3 4 5 6 7 8 9 10 11 12 13
14 15 16 17 18 19 20 21 22 23 24 25

INJECTION MULTIPPOINT MOTEURS XU*J*

2
3

A JOUR LE: 01-09-90

NOM: WOUTH

TEL: 4319

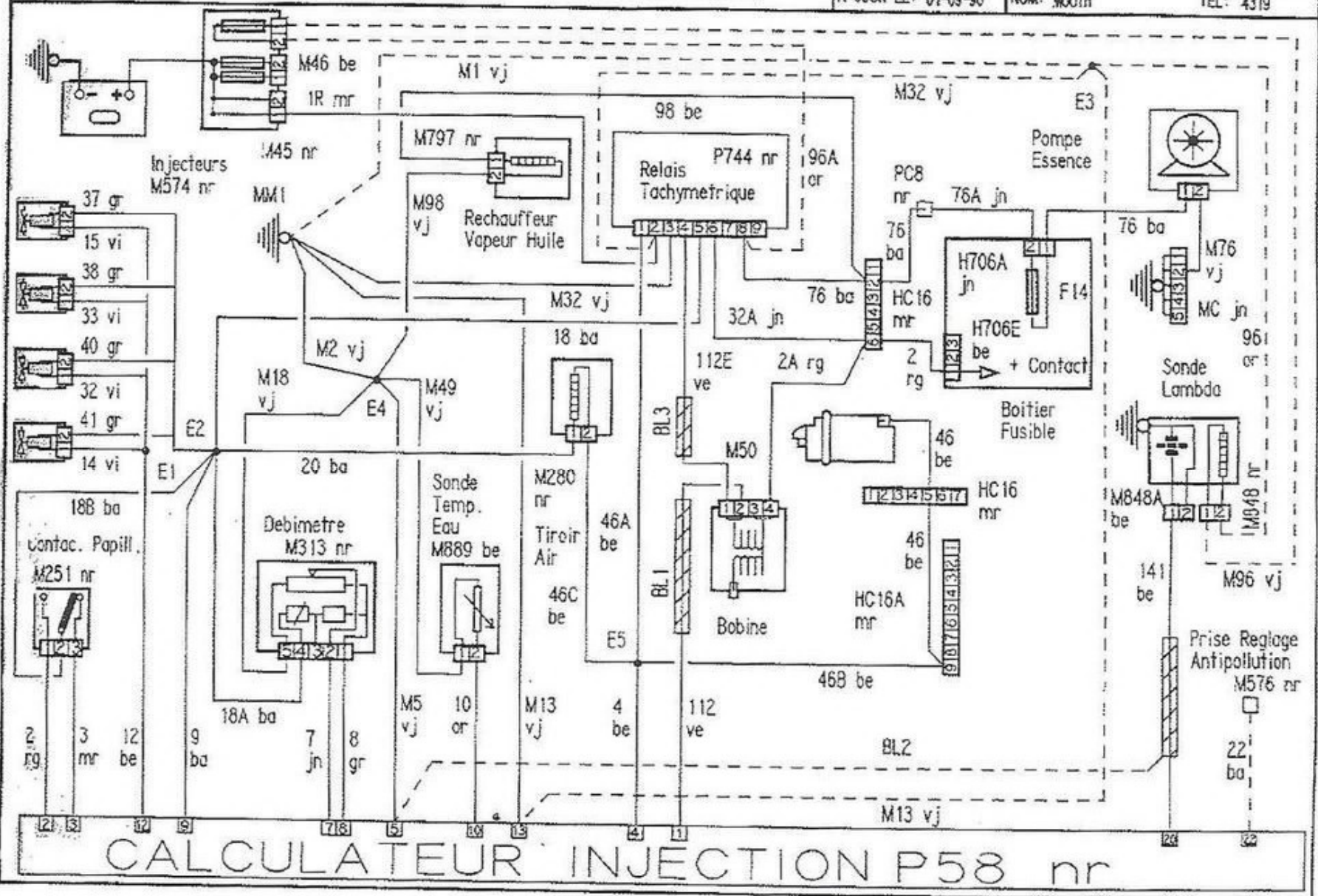

CALCULATEUR INJECTION P58 nr

NOTA 2 : Mise en place d'une resistance
d'adaptation en apres vente

INJECTION MULTIPOINT MOTEUR XU9J JAZ

2
4

A JOUR LE: 01-09-90

NOM: SOUTH

TEL: 4319

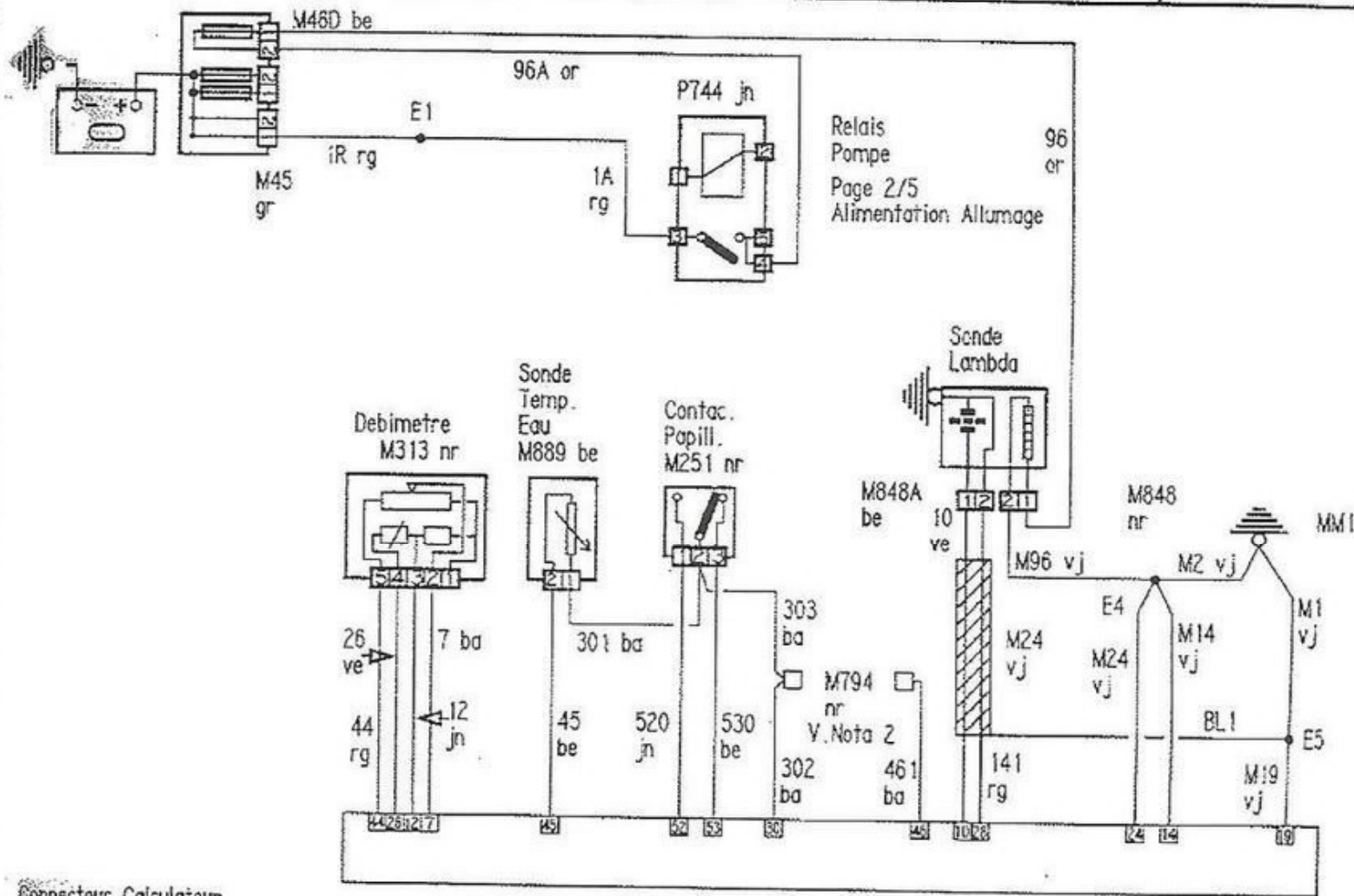

Relais
Pompe
Page 2/5
Alimentation Allumage

Connecteur Calculateur

CALCULATEUR INJECTION

1	2	3	4	5	6	7	8	9	10	11	12	13	14	15	16	17	18	19																	
20	21	22	23	24	25	26	27	28	29	30	31	32	33	34	35	36	37	38	39	40	41	42	43	44	45	46	47	48	49	50	51	52	53	54	55

P58 nr

Connecteur Calculateur 55 Voies

1	2	3	4	5	6	7	8	9	10	11	12	13	14	15	16	17	18	19	20
21	22	23	24	25	26	27	28	29	30	31	32	33	34	35	36	37	38	39	40
41	42	43	44	45	46	47	48	49	50	51	52	53	54	55					

NOTA : Rechauffeur Vapeur Huile
- GRAND FROID

INJECTION XU9J JAZ
ALIMENTATION ALLUMAGE

2/5

A JOUR LE: 01-09-90

NOM: MOUTH

TEL: 4319

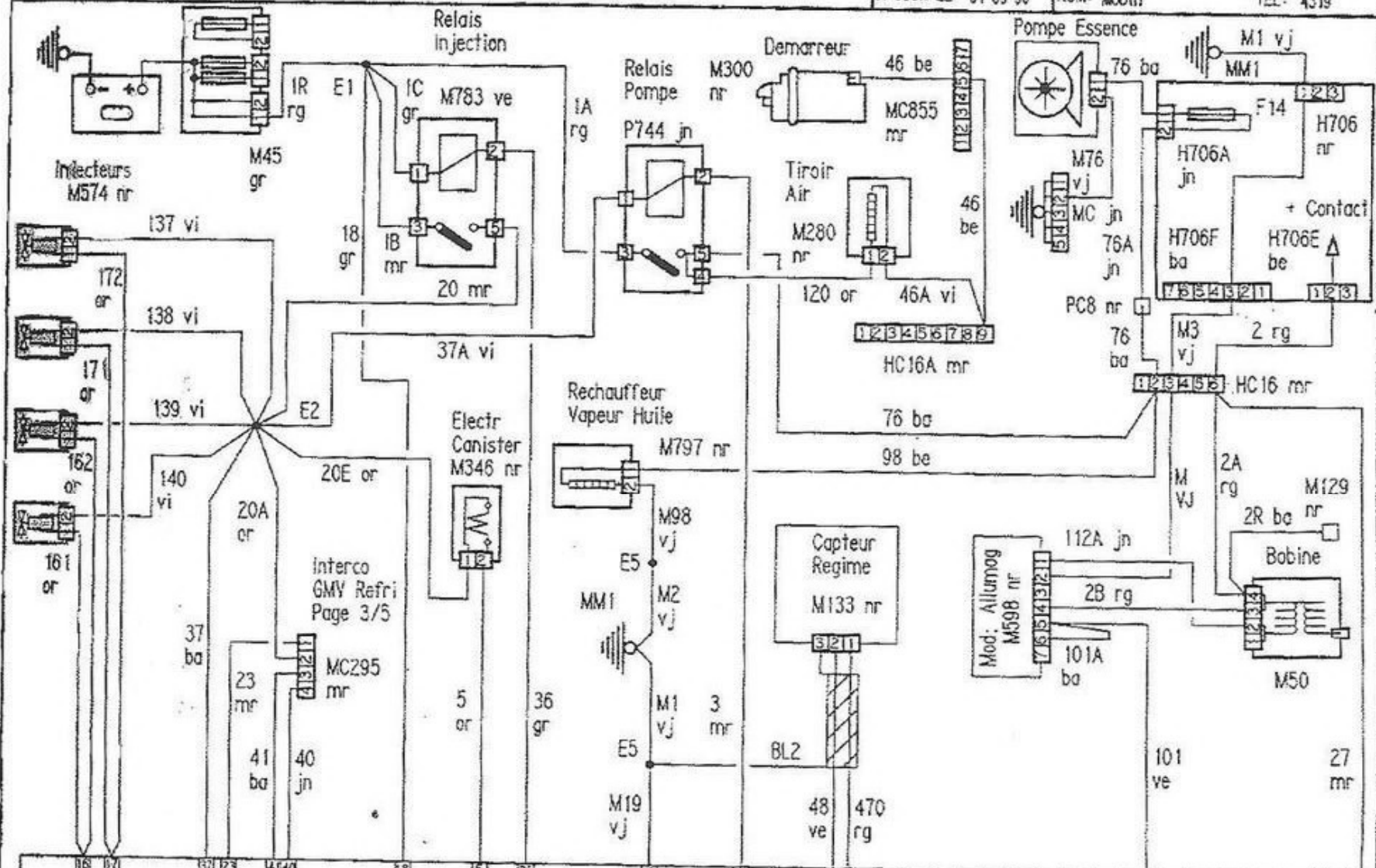

CALCULATEUR INJECTION P58 nr

TEMOIN AUTODIAGNOST.
XU9J JAZ - XU5M

2 / 6

A JOUR LE: 01-09-90

NOM: MOUTH

TEL: 4319

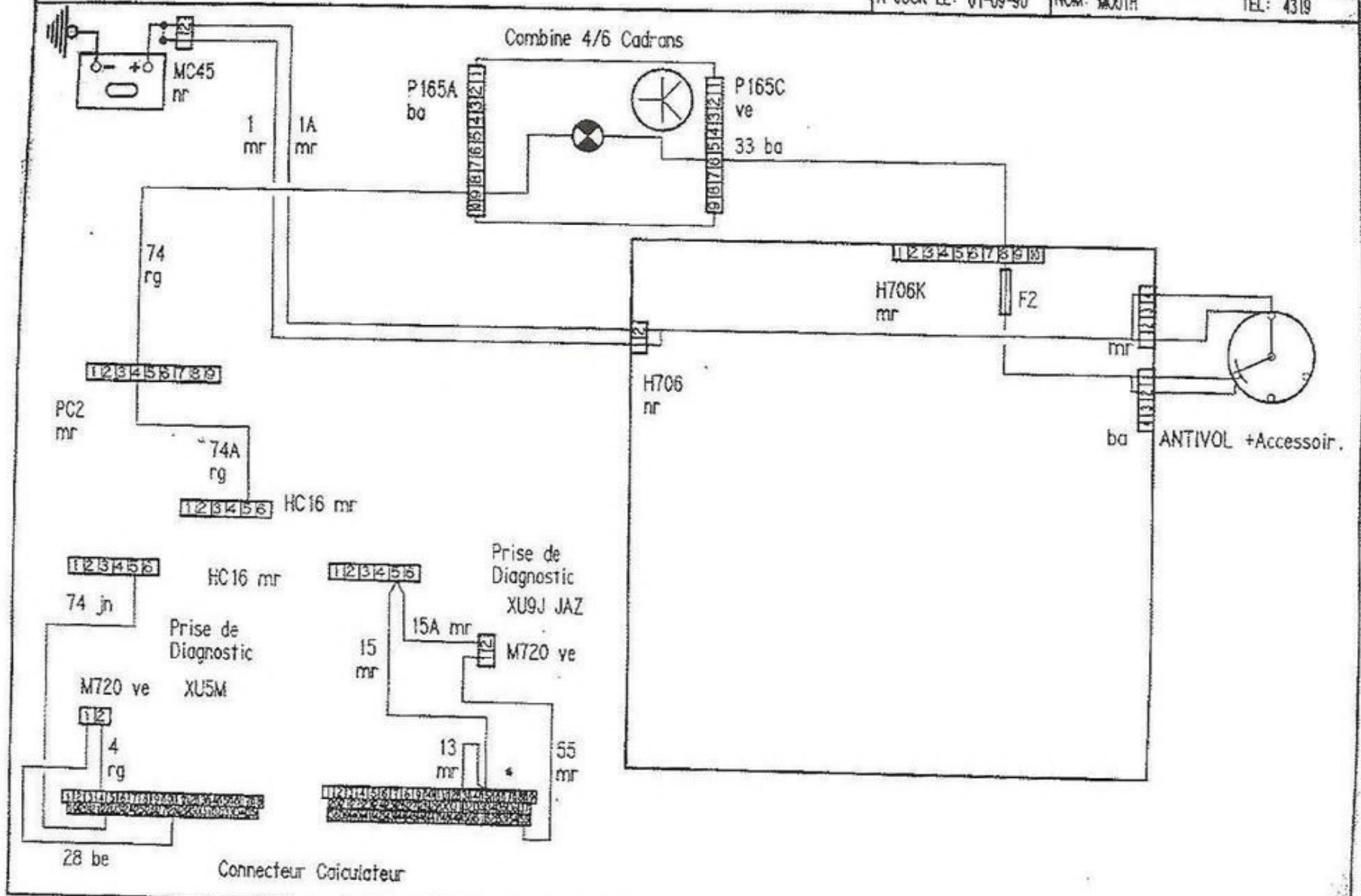

INJECTION MONOPOINT MOTEUR TU*M

2
7

A JOUR LE: 01-09-90

NOM: MOUTH

TEL: 4319

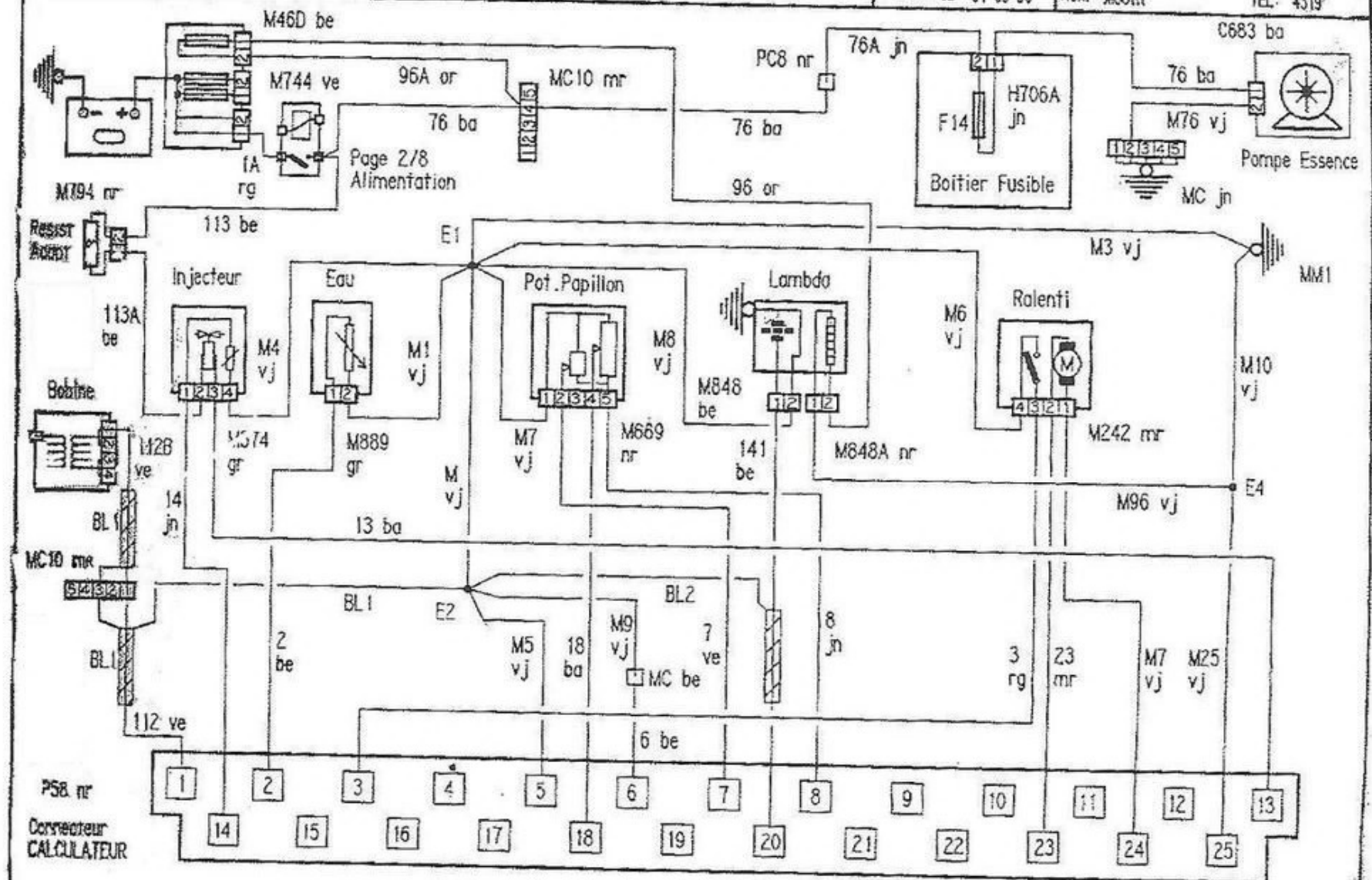

INJECT MONOPOINT TU*M ALIMENTATION

2
8

A JOUR LE: 01-09-90

NOM: MOUTH

TEL: 4319

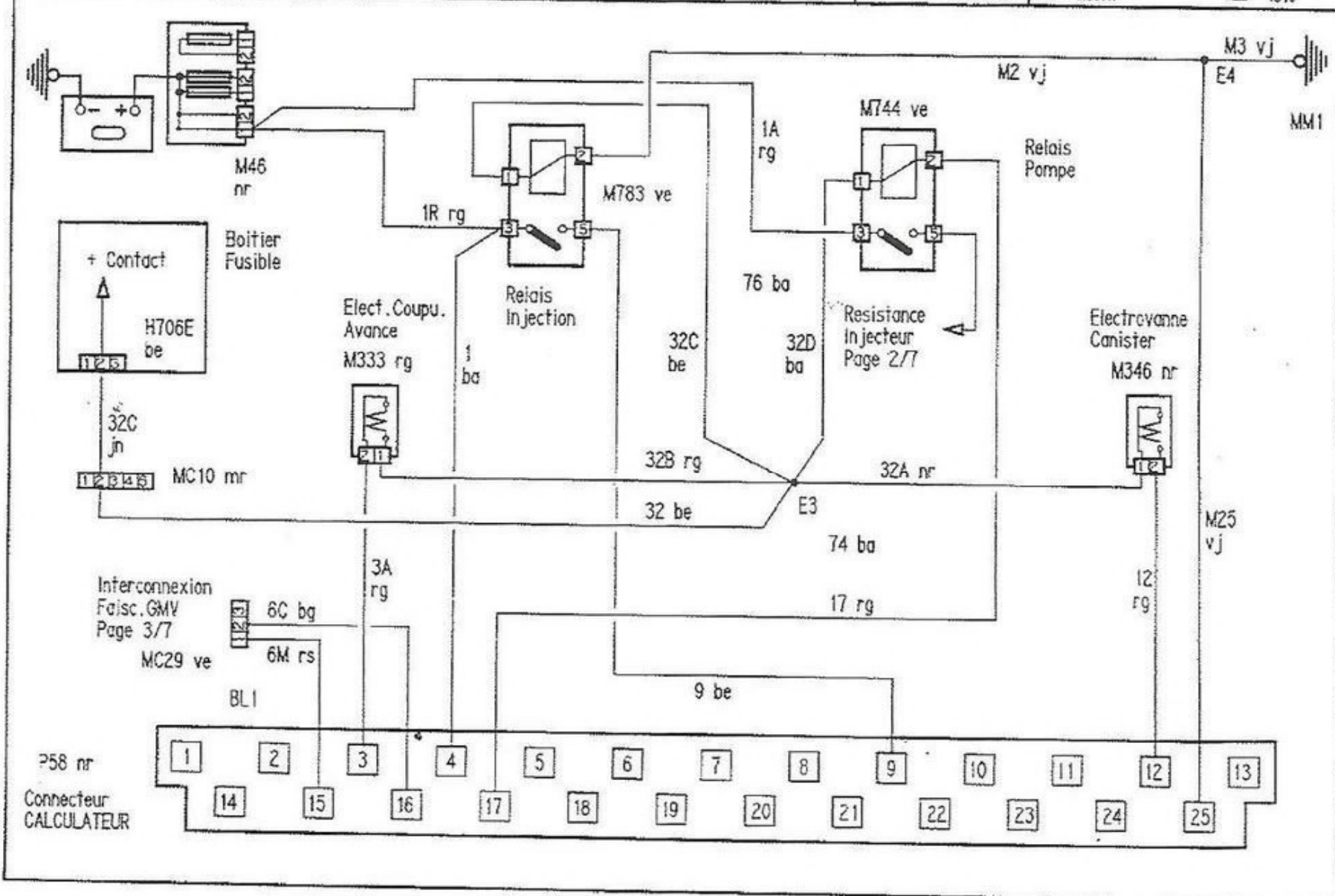

TEMOIN AUTODIAGNOST. TU*M

2/9

A JOUR LE: 01-09-90

NOM: MOUTH

TEL: 4319

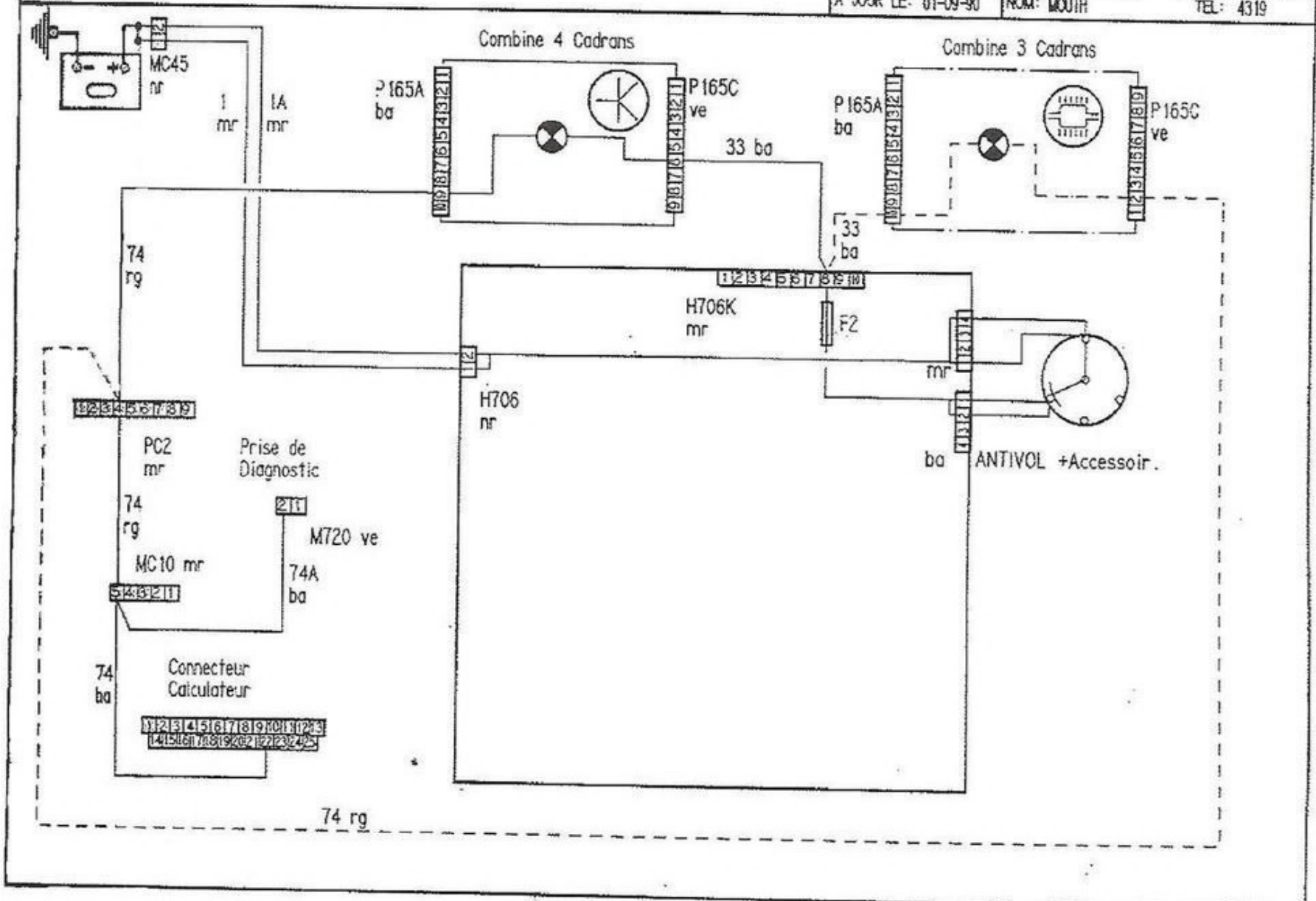

ALLUMAGE MOTEUR TU

2/11

A JOUR LE: 01-09-90

NOM: MOUTH

TEL: 4319

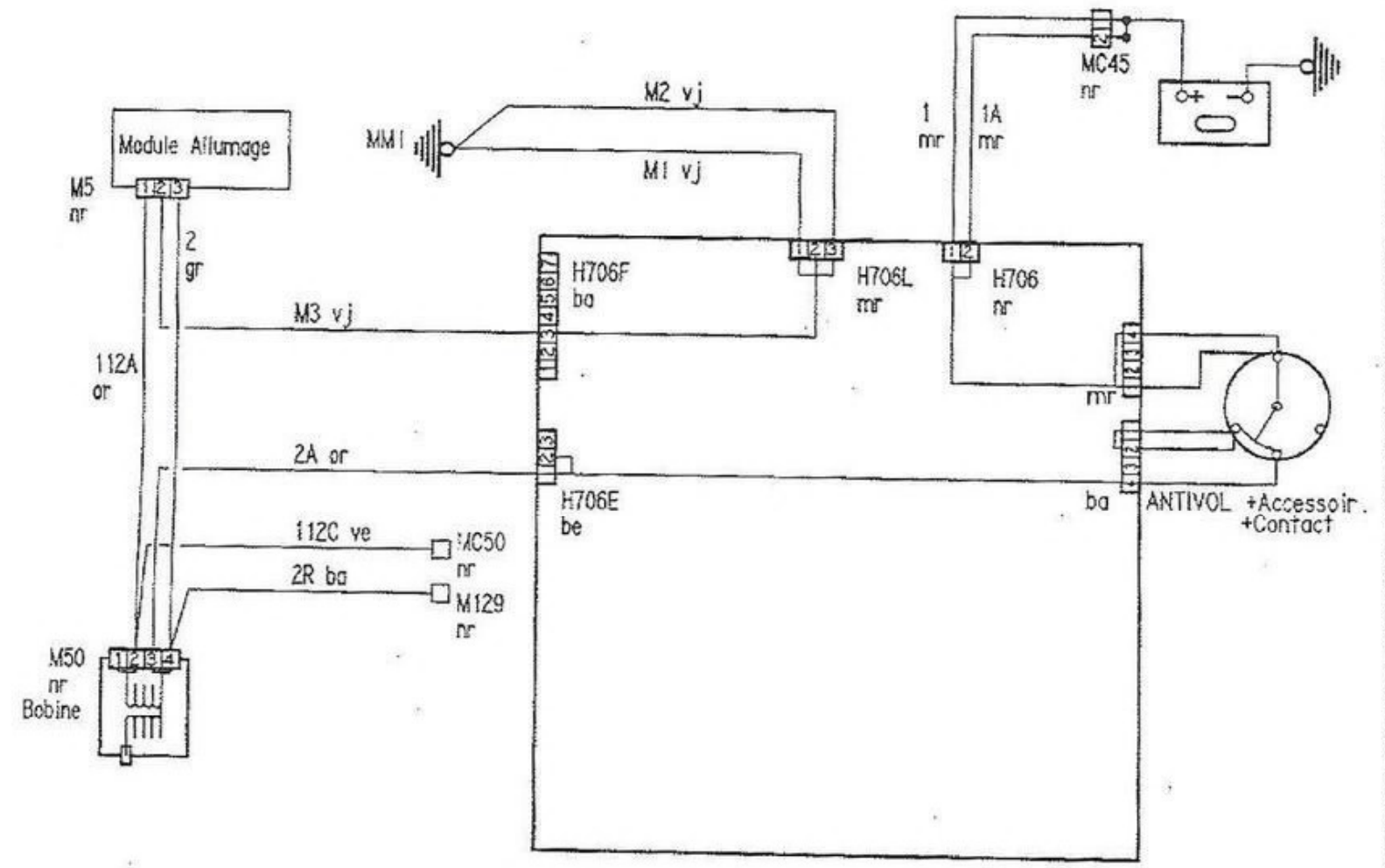

INJECTION MONOPOINT MOTEUR XU5M

2/15

A JOUR LE: 01-09-90

NOM: MOUTH

TEL: 4319

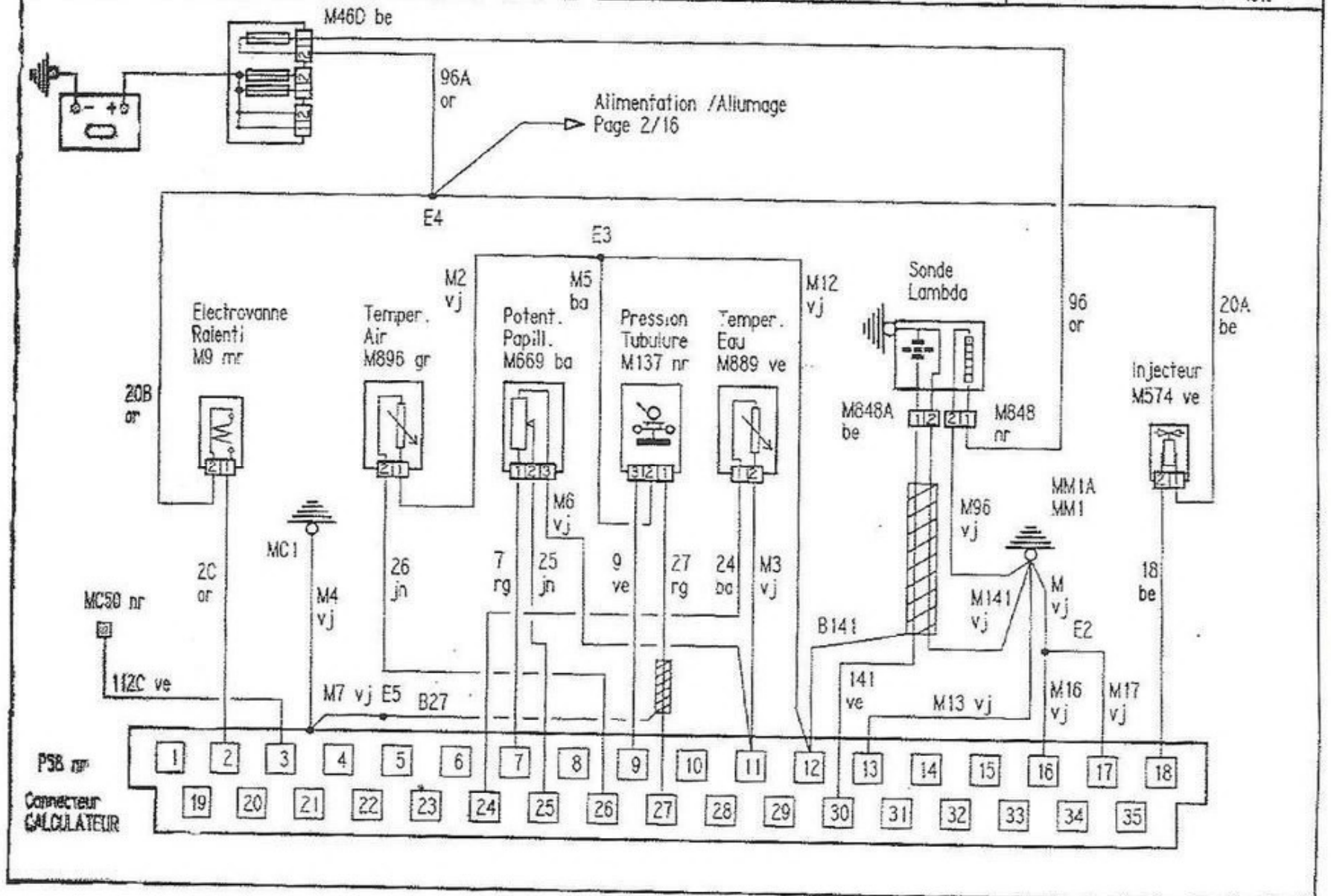

INJECT MONOPOINT XU5M ALIMENTATION ALLUMAGE

2/16

A JOUR LE: 01-09-90 NOM: MOUTH TEL: 4319

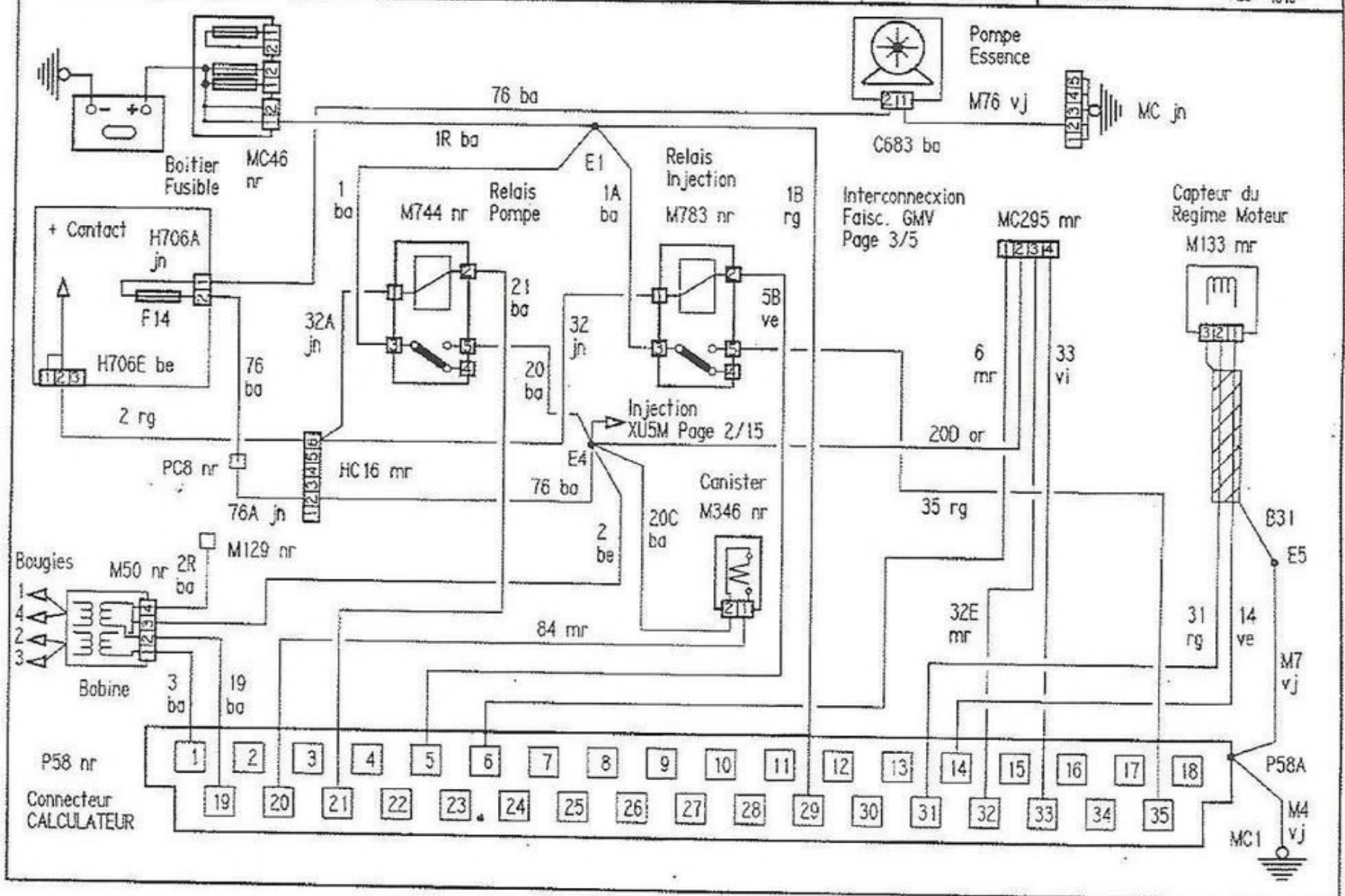

Thermocontact M850:
 -B enclenche: V1 V2 en serie
 -B+H enclenches: V1 V2 en parallele

TYPE CONCERNE:
 -205-REFRI

GRUPE MOTOVENTILATEURS

3/4

A JOUR LE: 01-07-90

NOM: MOUTH

TEL: 4319

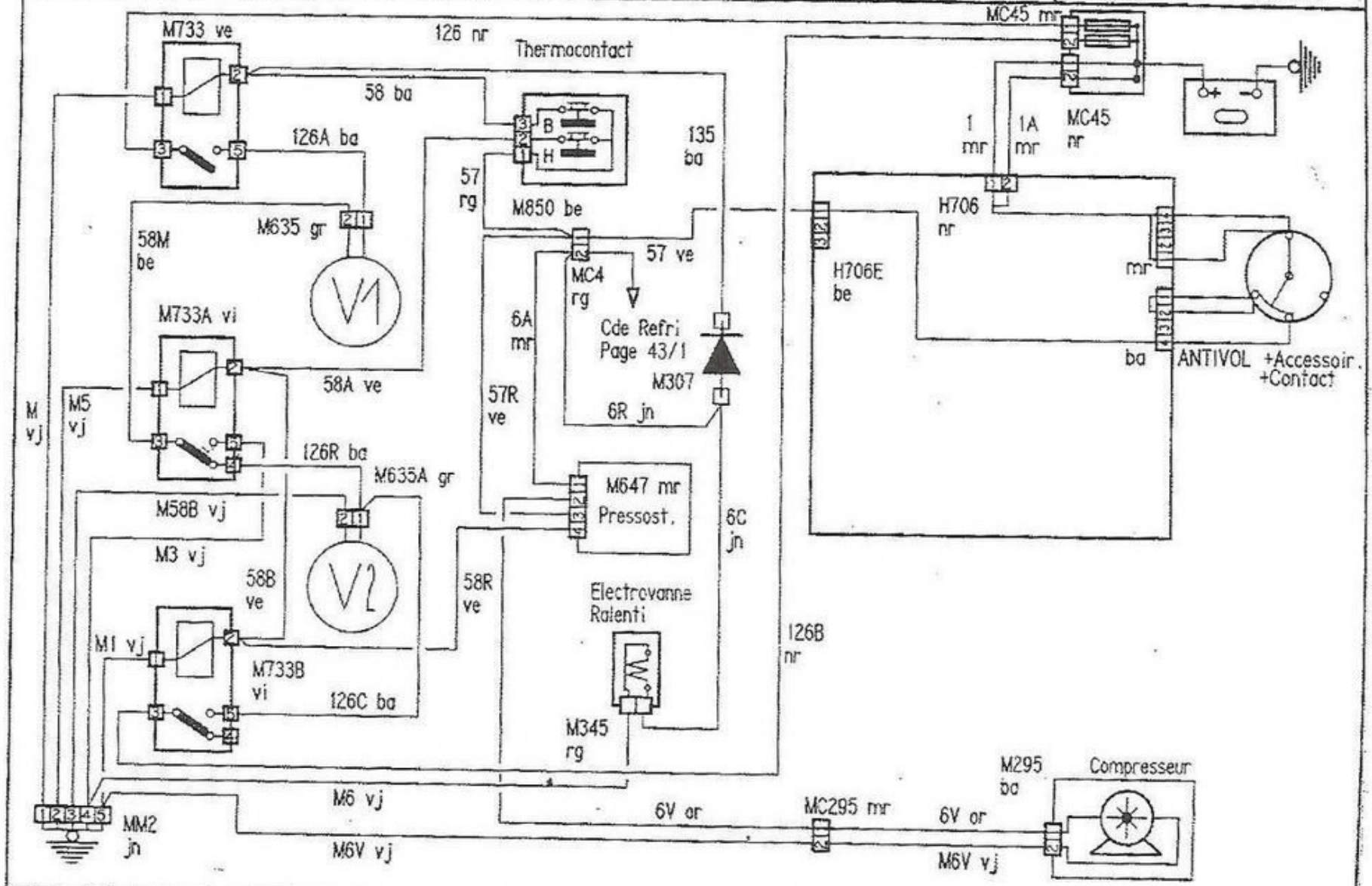

MOTOVENTILATEUR 1 VITESSE

3/1

A JOUR LE: 01-07-90

NOM: MOUTH

TEL: 4319

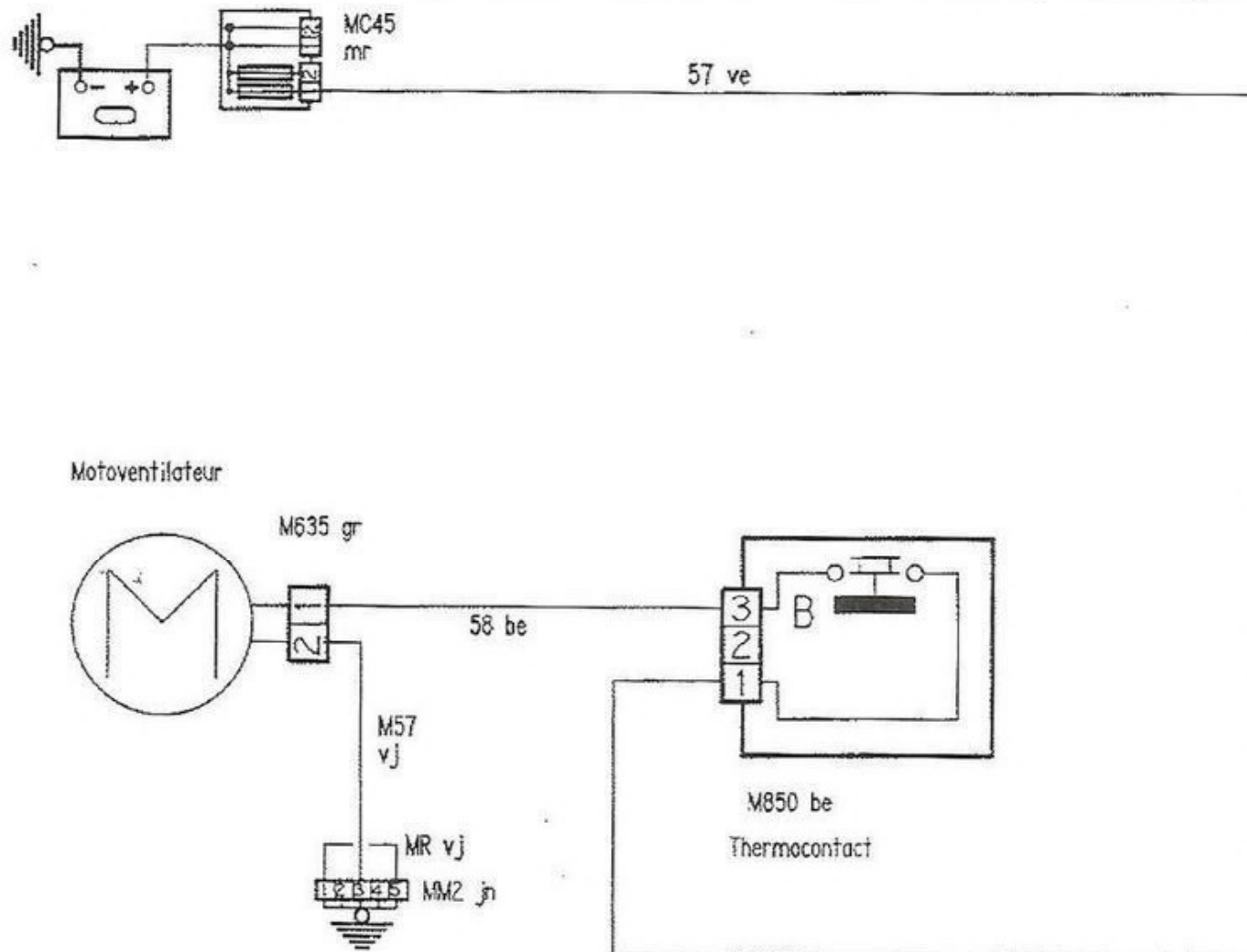

MOTOVENTILATEUR 2 VITESSES

3
2

A JOUR LE: 01-07-90

NOM: MOUTH

TEL: 4319

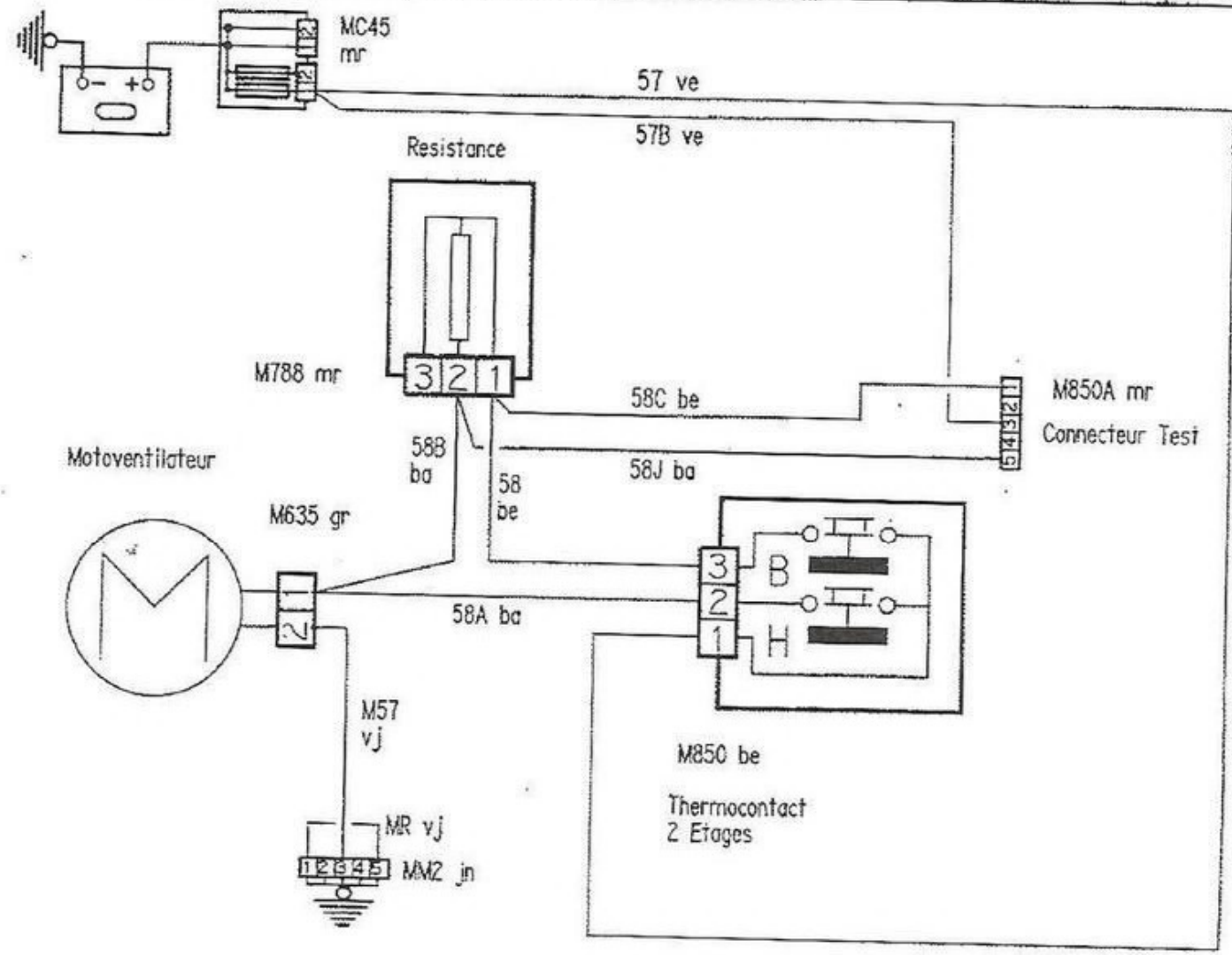

Thermocontact M850:
 -B enclenche: V1 V2 en serie
 -B+H enclenches: V1 V2 en parallele

TYPE CONCERNE:
 -205-REFRI XU9JAZ
 -205-REFRI XU5M

GRUPE MOTOVENTILATEURS

3/5

A JOUR LE: 01-07-90

NOM: MOUTH

TEL: 4319

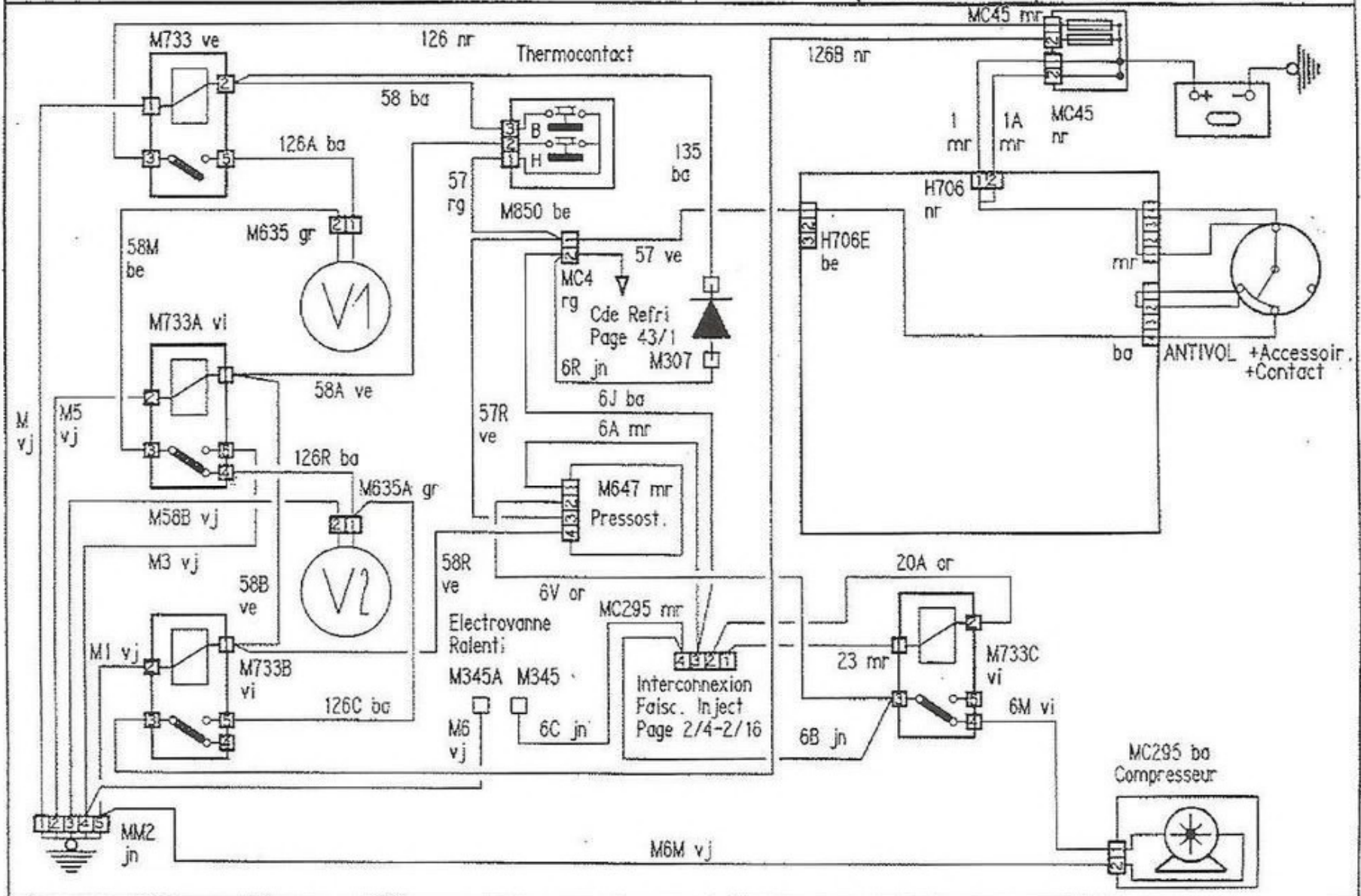

Thermocontact M850:
 -B enclenche: V1 V2 en serie
 -B+H enclenches: V1 V2 en parallele

TYPE CONCERNE:
 -205-DSL
 -XU9J1

GRUPE MOTOVENTILATEURS

3/3

A JOUR LE: 01-07-90

NOM: MOUTH

TEL: 4319

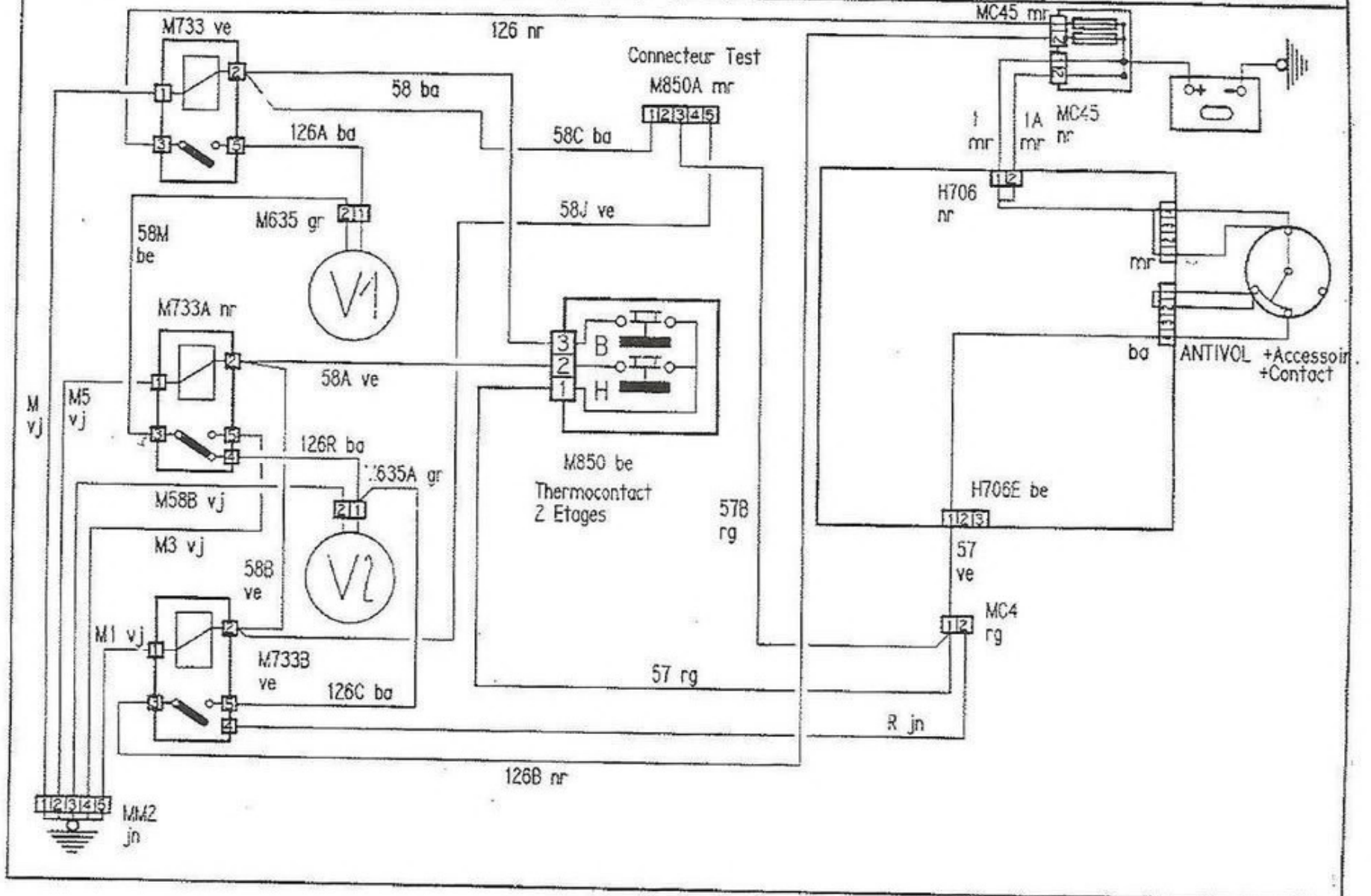

Thermocontact M850:
 -B enclenche: V1 V2 en serie
 -B+H enclenches: V1 V2 en parallele

TYPE CONCERNE:
 -TU*M-REFRI

GRUPE
 MOTOVENTILATEURS

3
 7

A JOUR LE: 01-07-90

NOM: MOUITH

TEL: 4319

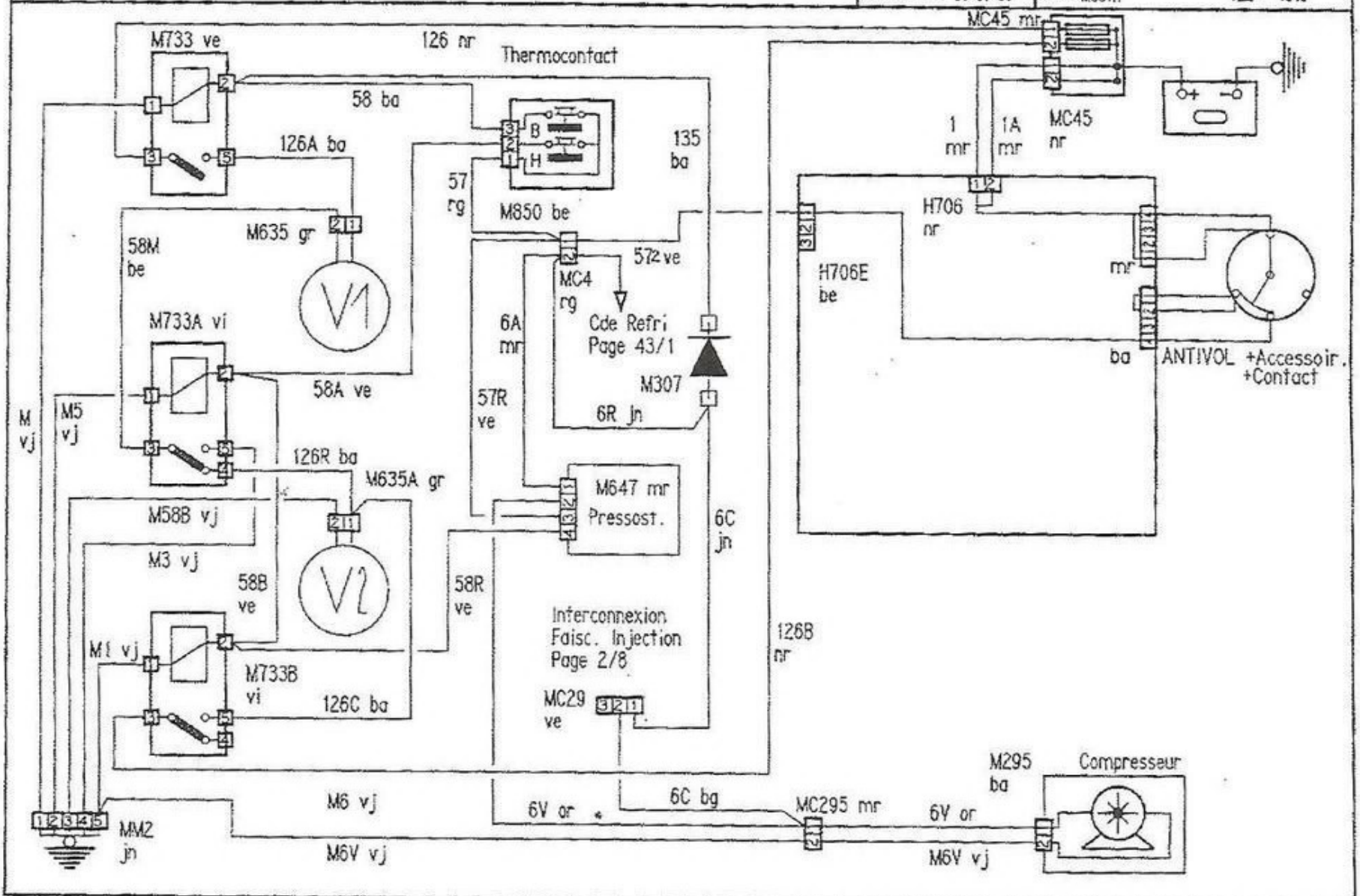

B ENCLENCHE: PETITE VITESSE
B+H ENCLENCHES: GRANDE VITESSE

TYPES CONCERNES:
-RALLYE

MOTOVENTILATEUR 2 VITESSES

3/6

A JOUR LE: 01-07-90

NOM: MOUTH

TEL: 4319

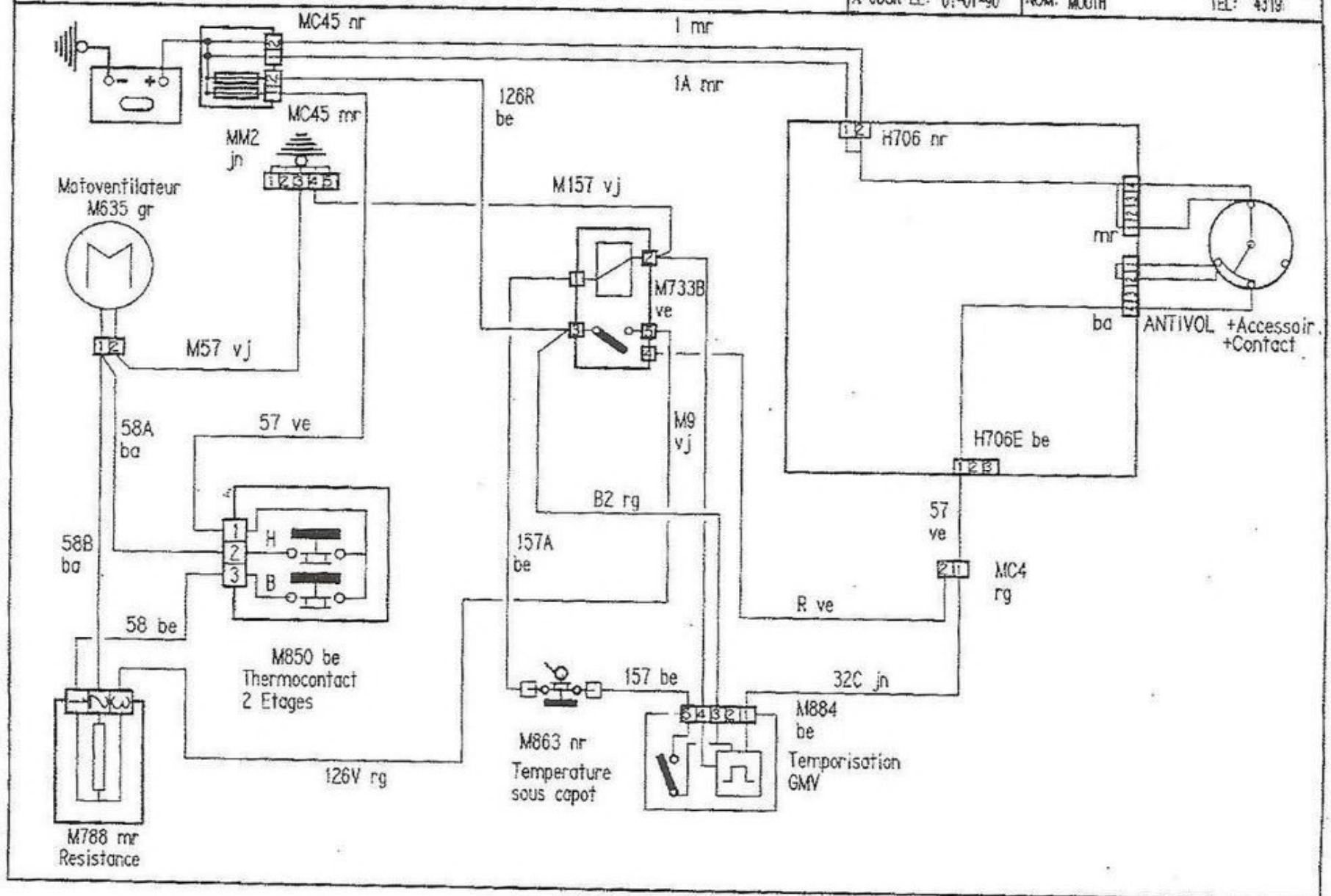

TEMOIN STARTER

4
1

A JOUR LE: 01-09-90

NOM: MOUTH

TEL: 4319

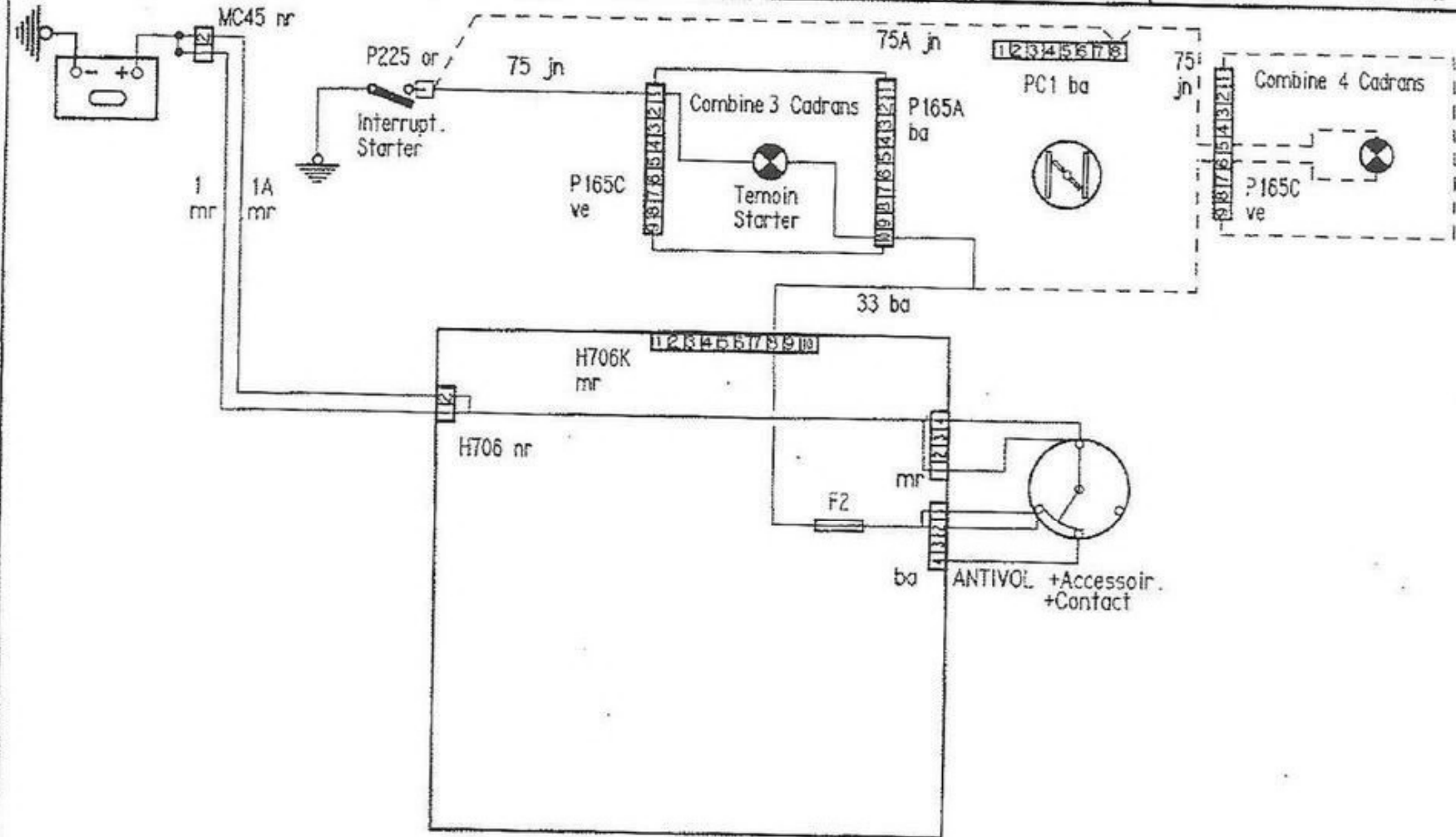

EN POINTILLES : Moteurs XU*J*

TYPES CONCERNES :
-205 AVEC COMBINE 4/6 CADRANS
MOTEURS XU

COMPTE TOURS MOTEURS XU

5
1

A JOUR LE: 01-09-90

NOM: MOUTH

TEL: 4319

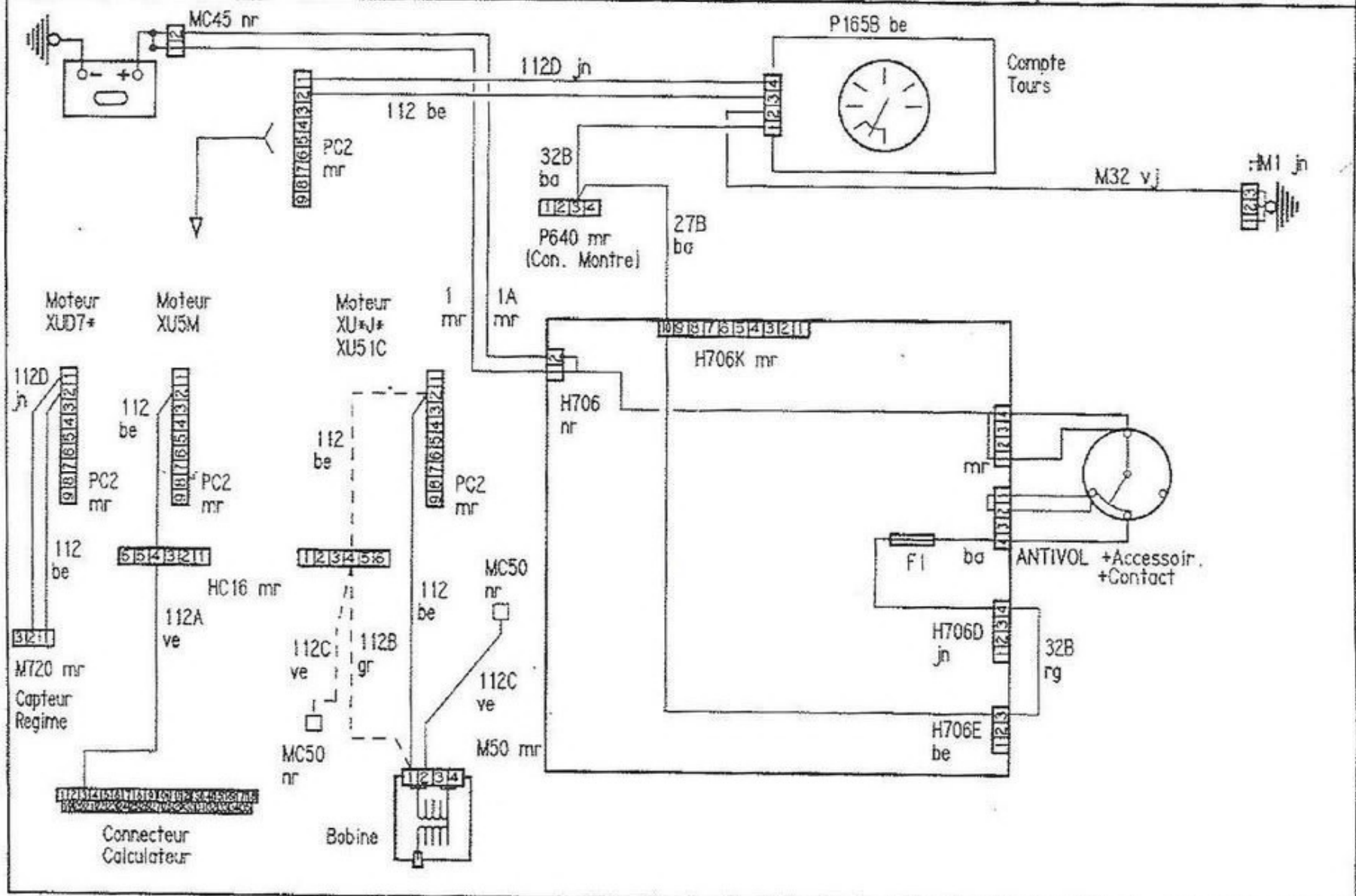

EN POINTILLES : Moteurs TU Depollue

TYPES CONCERNES :
-205 AVEC COMBINE 4 CADRANS
MOTEURS TU

COMPTE TOURS MOTEURS TU

5
2

A JOUR LE: 01-09-90

NOM: MOUTH

TEL: 4319

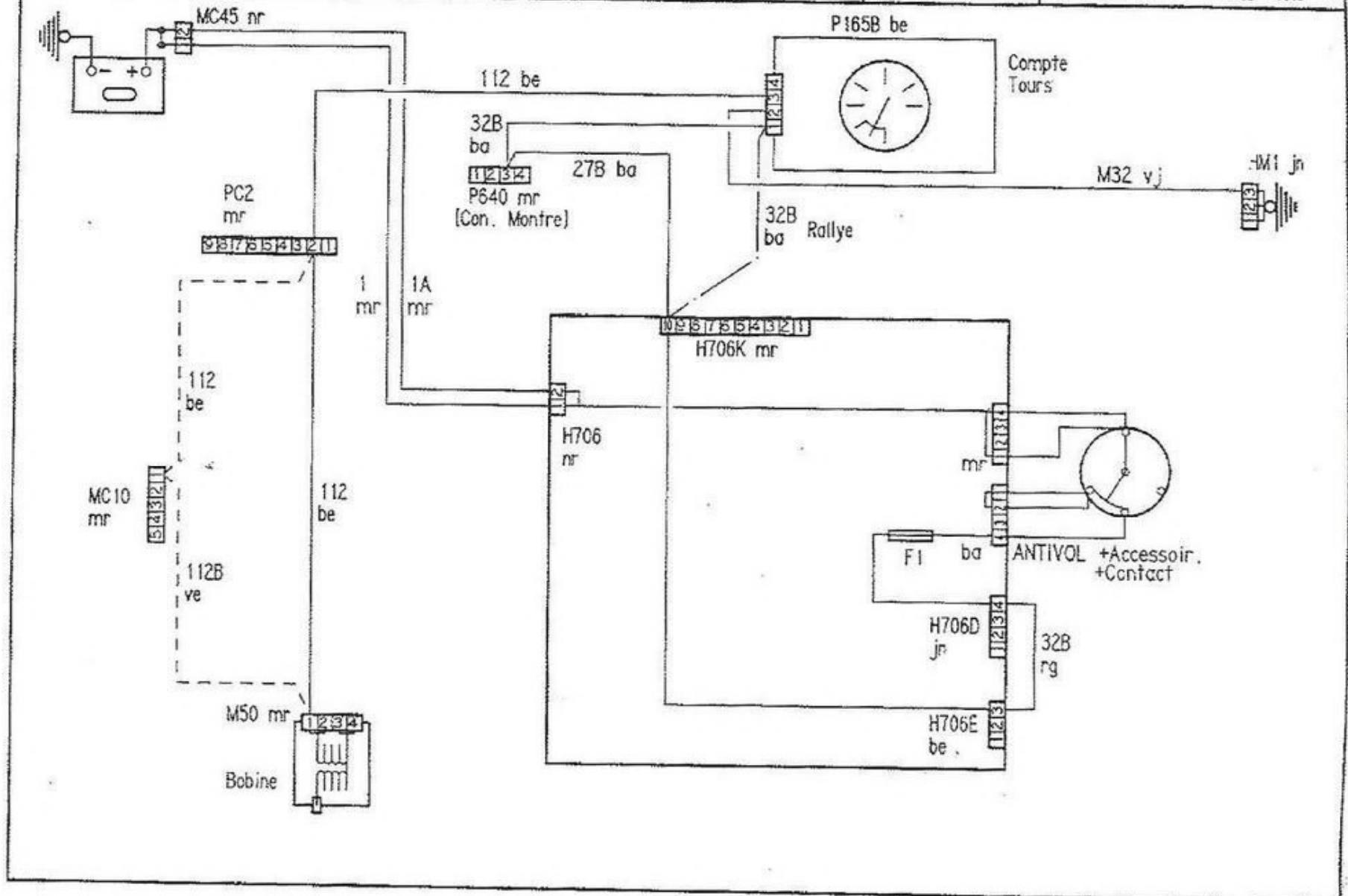

TEMOIN NIVEAU EAU
XUD9 EGR - XUD7T

6/2

A JOUR LE: 01-09-90

NOM: MOUTH

TEL: 4319

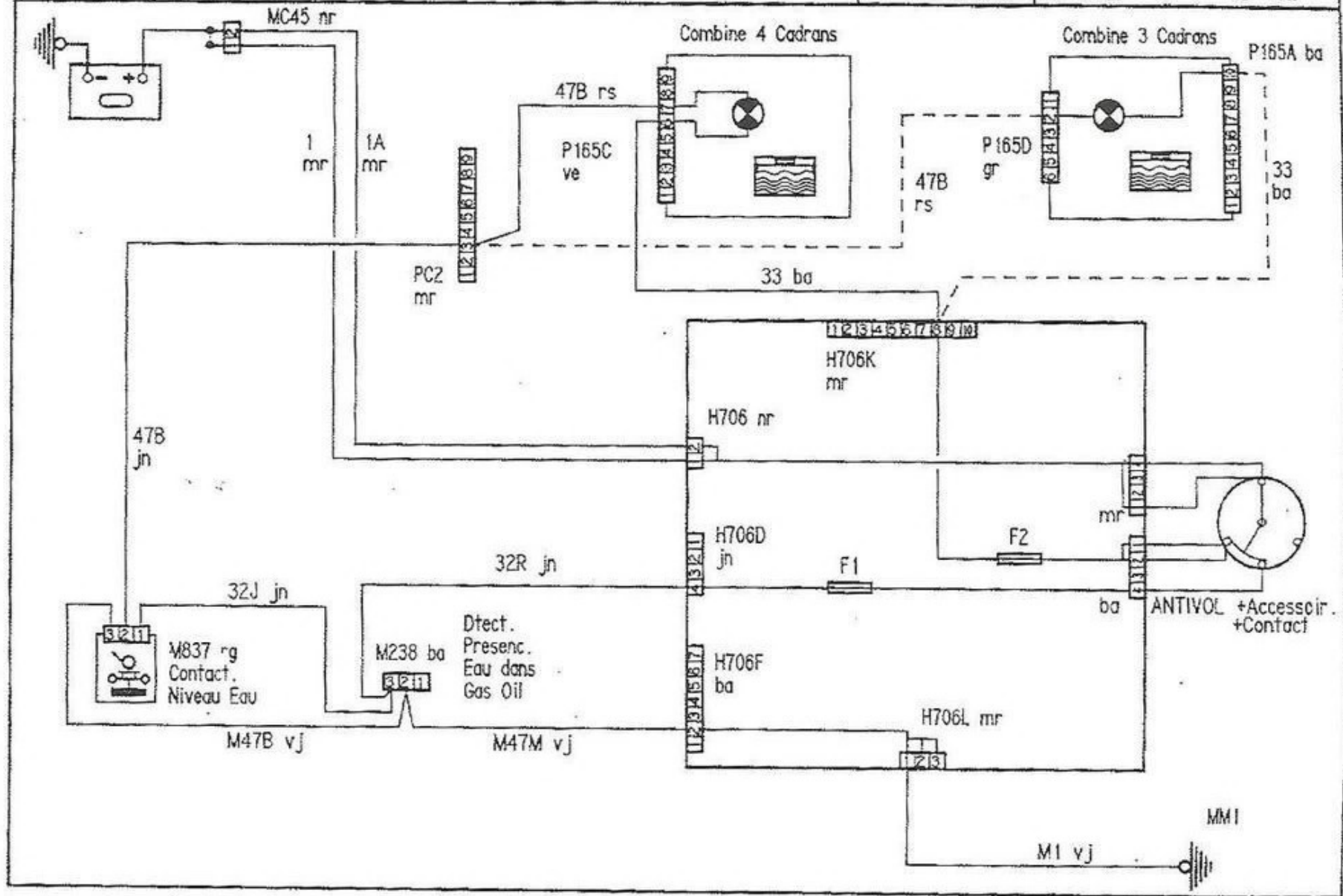

EN POINTILLES : 205 Diesel

TYPES CONCERNES:
-205 AVEC COMBINE
3 CADRANS

TE.: STOP, PRESS. HUILE
TEMP. EAU, NIVEAU EAU

7
3

A JOUR LE: 01-09-90

NOM: MOUTH

TEL: 4319

TEMOINS :

Stop
Pression Huile
Temperature Eau
Niveau Eau

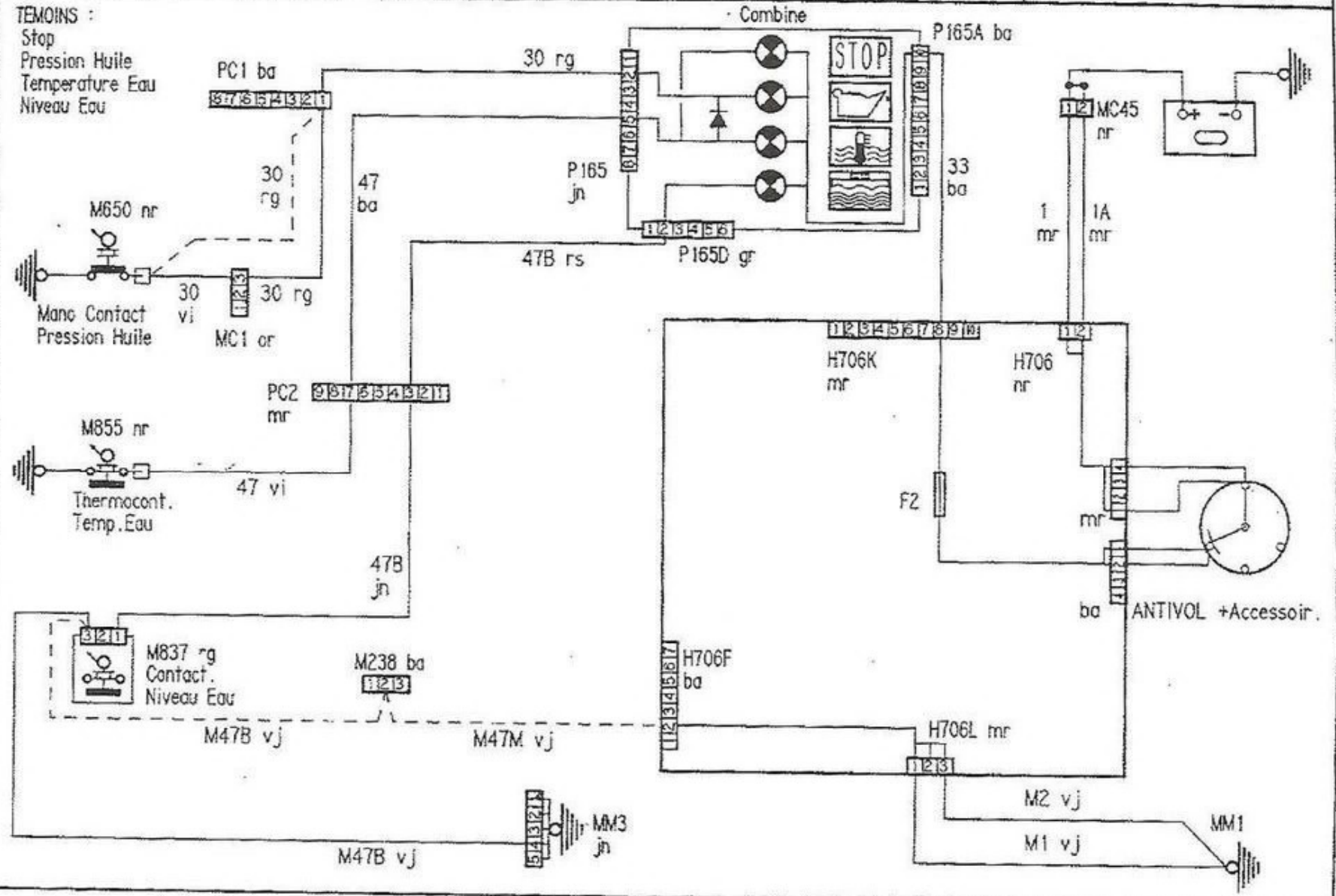

EN POINTILLES : Direction Droite

TYPES CONCERNES:
-205 AVEC COMBINE
6 CADRANS GTI

TE.: STOP, PRESS. HUILE
TEMP. EAU, NIVEAU EAU

7
1

A JOUR LE: 01-09-90

NOM: MOUTH

TEL: 4319

TEMOINS :
Stop
Pression Huile
Temperature Eau
Niveau Eau

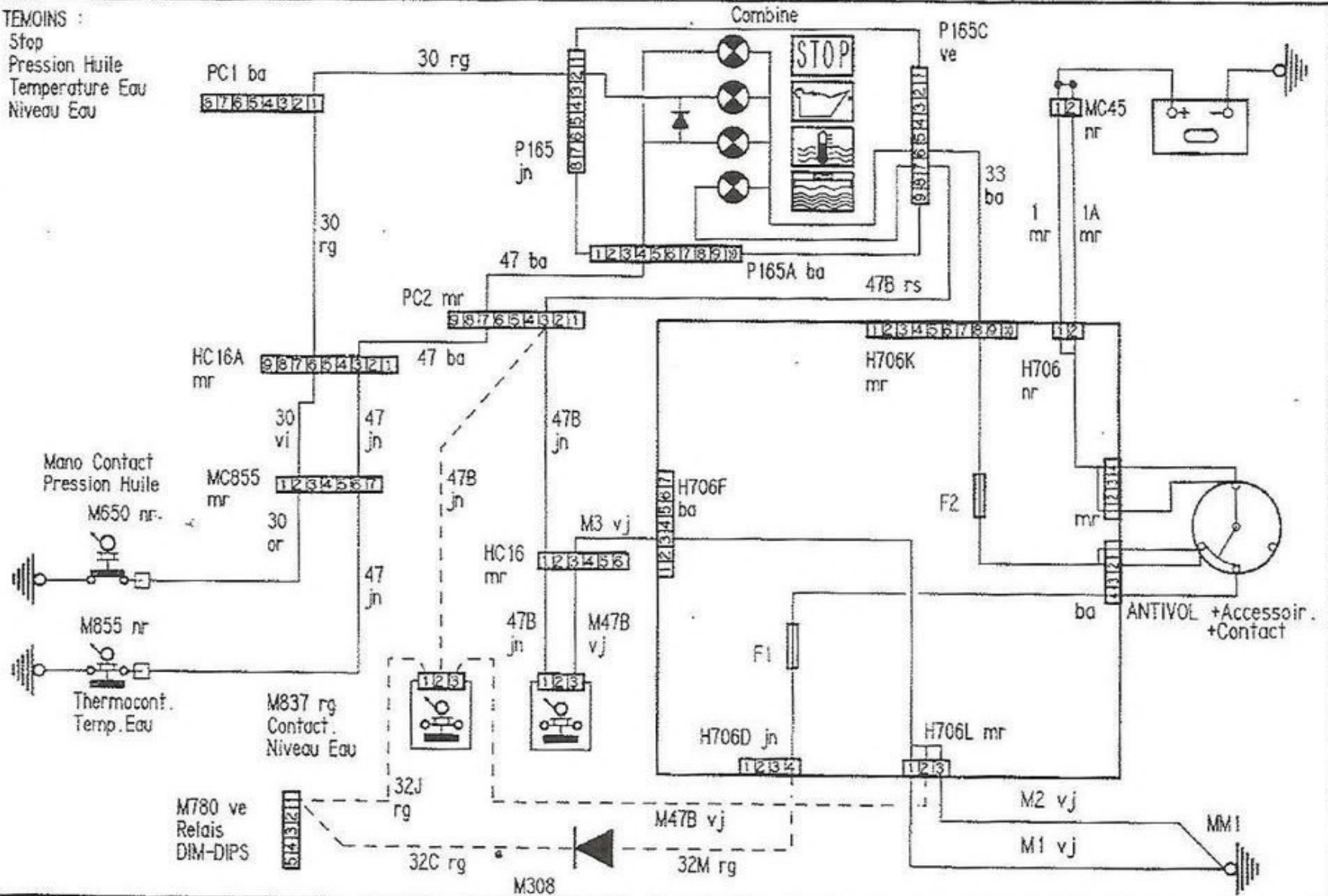

EN POINTILLES : 205 Diesel

TYPES CONCERNES:
-205 AVEC COMBINE
4 CADRANS SF GTI

TE.: STOP, PRESS. HUILE
TEMP. EAU, NIVEAU EAU

7
2

A JOUR LE: 01-09-90

NOM: MOUTH

TEL: 4319

TEMOINS :
Stop
Pression Huile
Temperature Eau
Niveau Eau

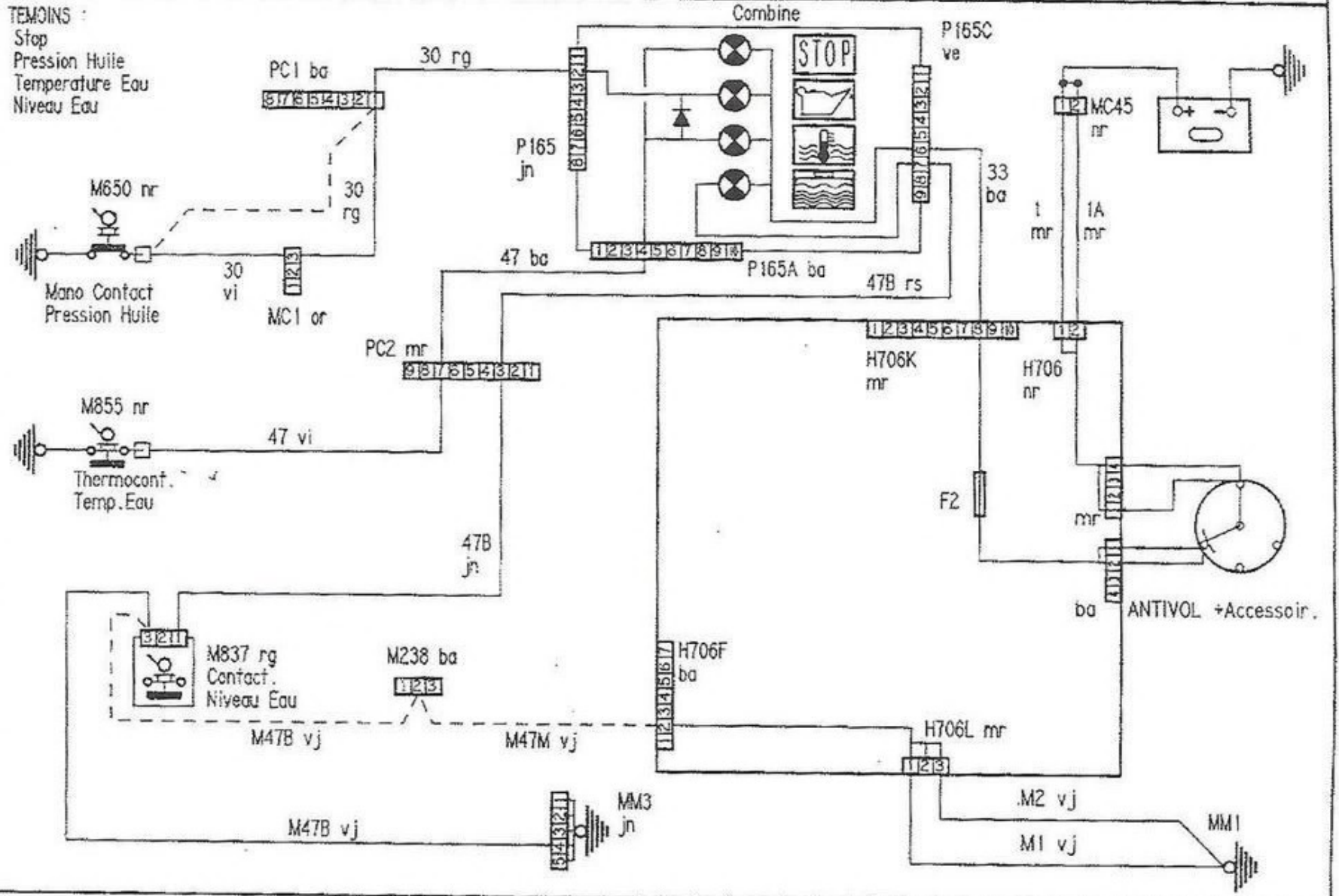

TYPE CONCERNE
-Moteur XU51C

POMPE IMMERGEE
TEMOIN HUILE

7
5

A JOUR LE: 01-09-90 NOM: MOUTH TEL: 4319

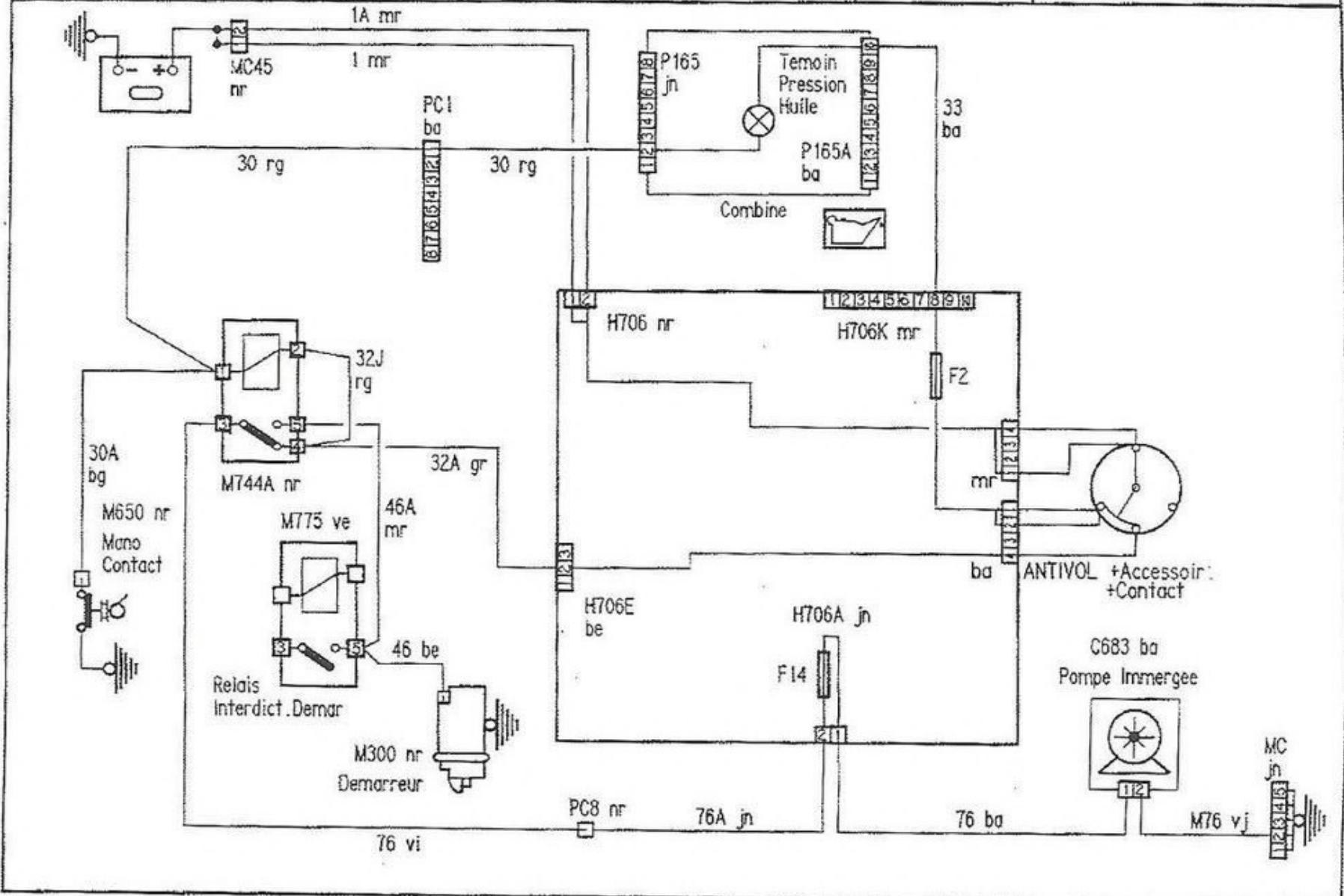

PC13 be : SPECIFIQUE DIRECTION A DROITE

TYPES CONCERNES:
-205 AVEC COMBINE
3 CADRANS

TEMOIN FREIN A MAIN
NIV. LIQU. USUR. PLAQ.

8
1

A. JOUR LE: 01-07-90

NOM: MOUTH

TEL: 4319

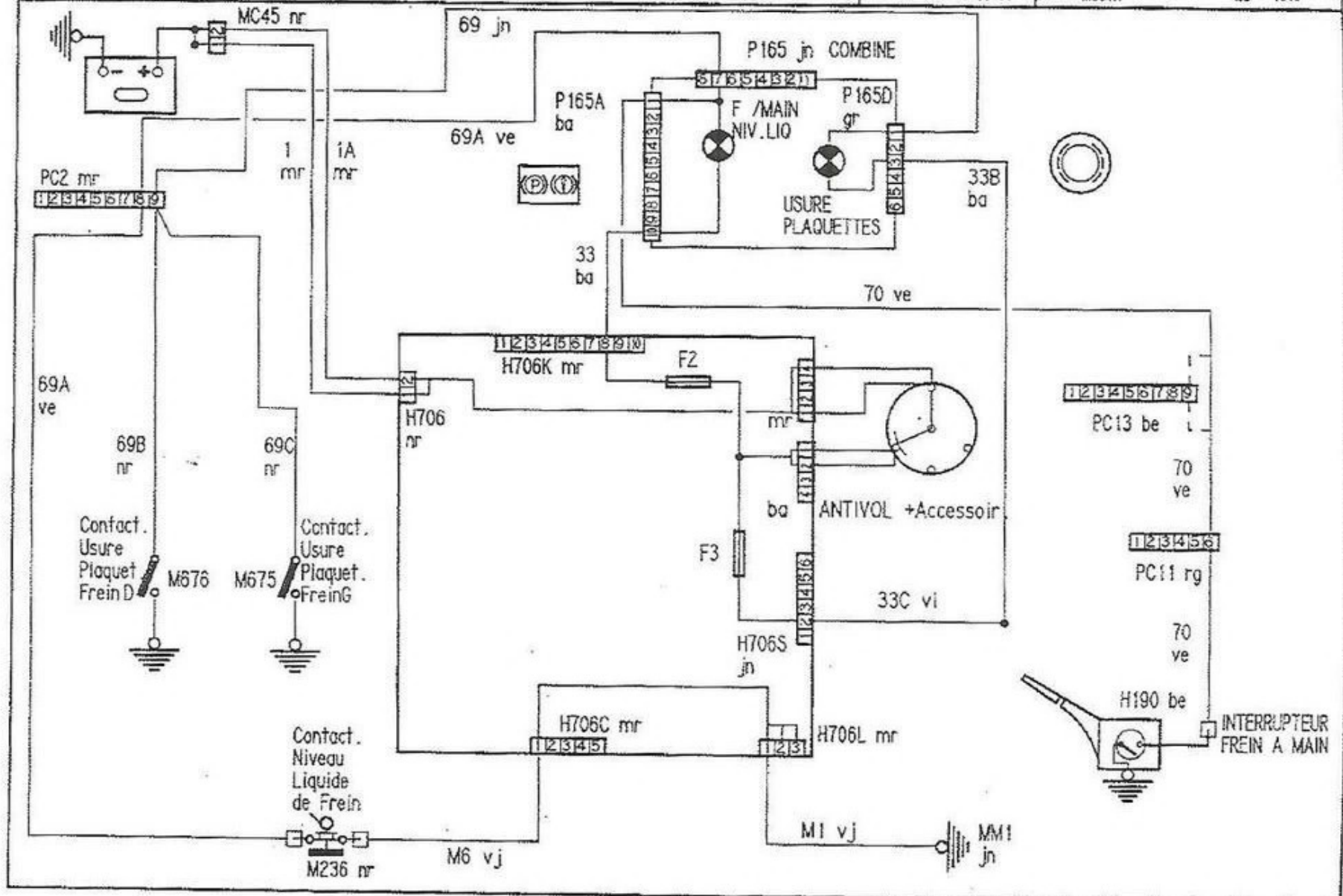

PC13 be : SPECIFIQUE DIRECTION A DROITE

TYPES CONCERNES:
-205 AVEC COMBINE
4 CADRANS

TEMOIN FREIN A MAIN
NIV. LIQ. USUR. PLAQ.

9
1

A JOUR LE: 01-07-90

NOM: MOUTH

TEL: 4319

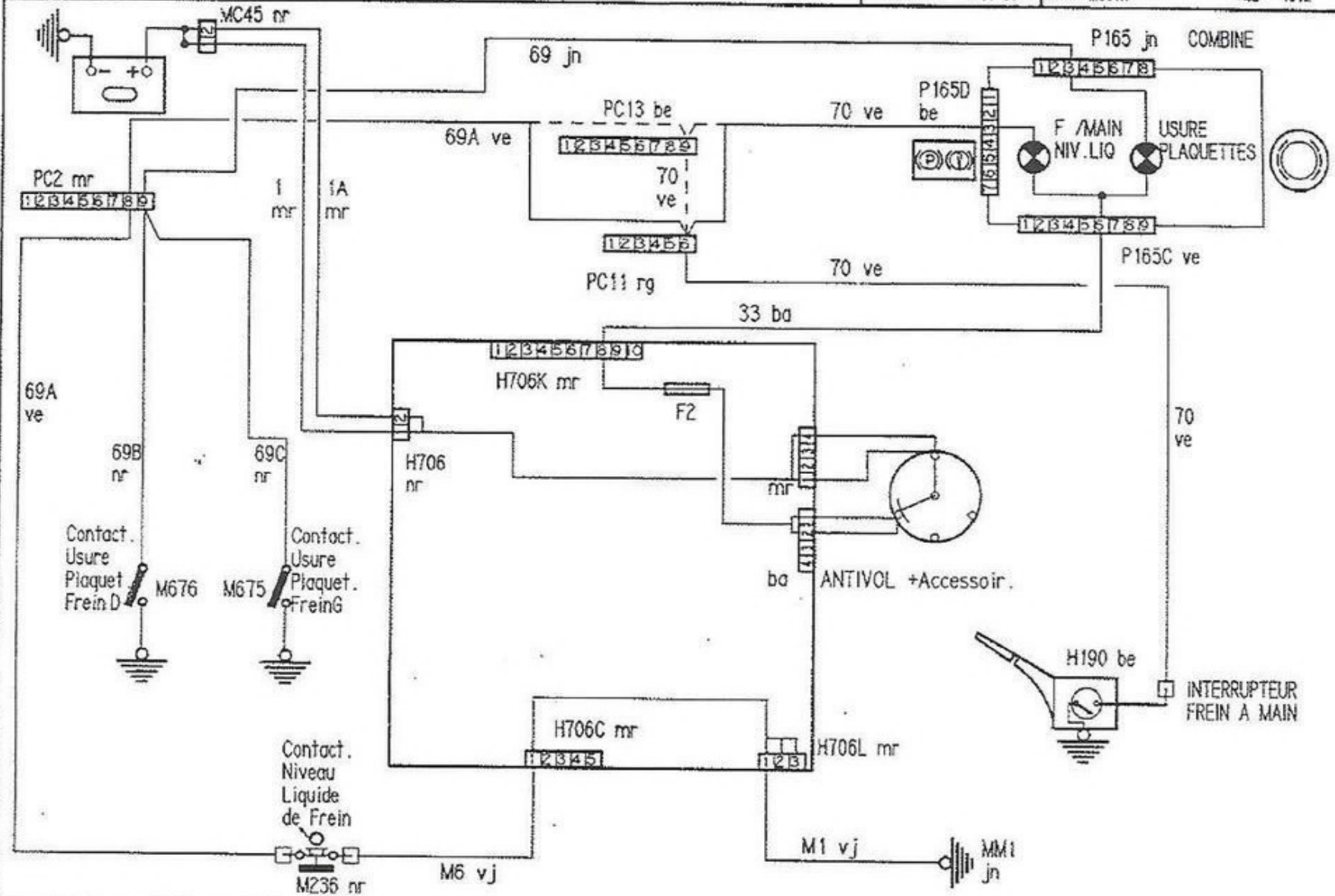

TEMOIN BRAKE AUSTRALIE

9/2

A JOUR LE: 01-09-90

NOM: MOUTH

TEL: 4319

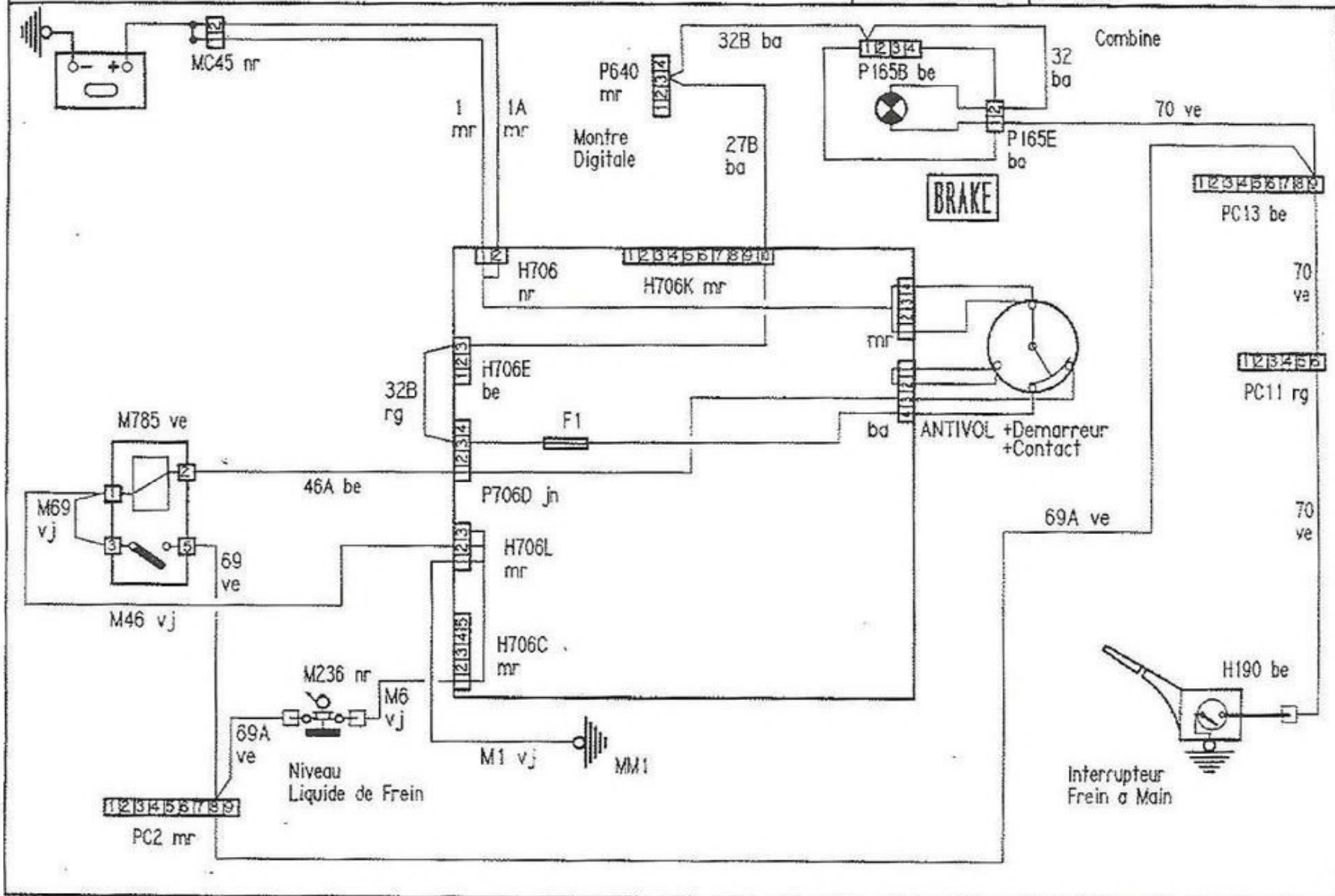

SONDE TEMPERATURE CATALYSEUR JAPON

9
6

A JOUR LE: 01-07-90

NOM: MOUTH

TEL: 4319

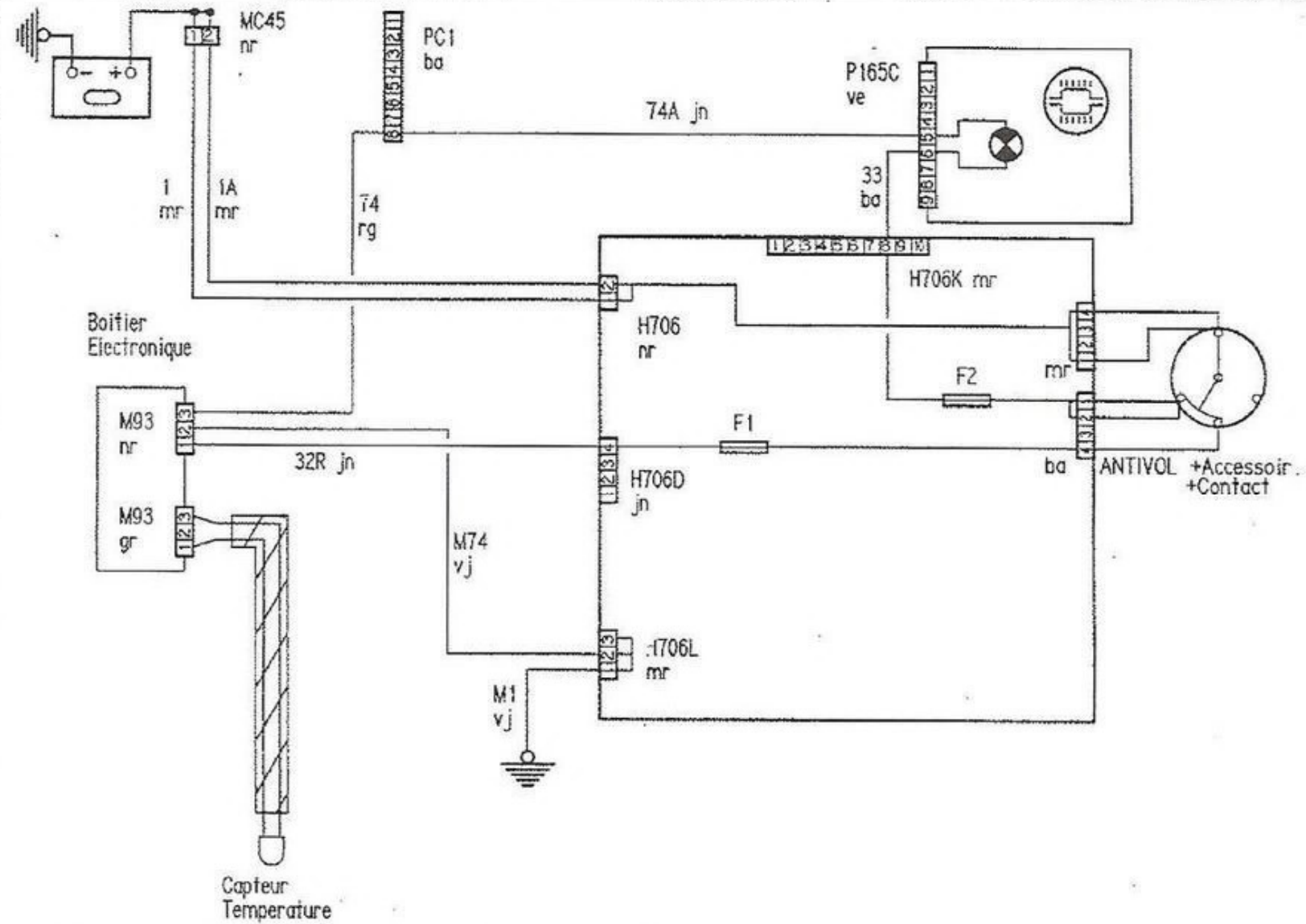

TYPE CONCERNE:
-205DSL

DETECTEUR PRESENCE D'EAU DANS GASOIL

10
1

A JOUR LE: 01-07-90

NOM: MOUTH

TEL: 4319

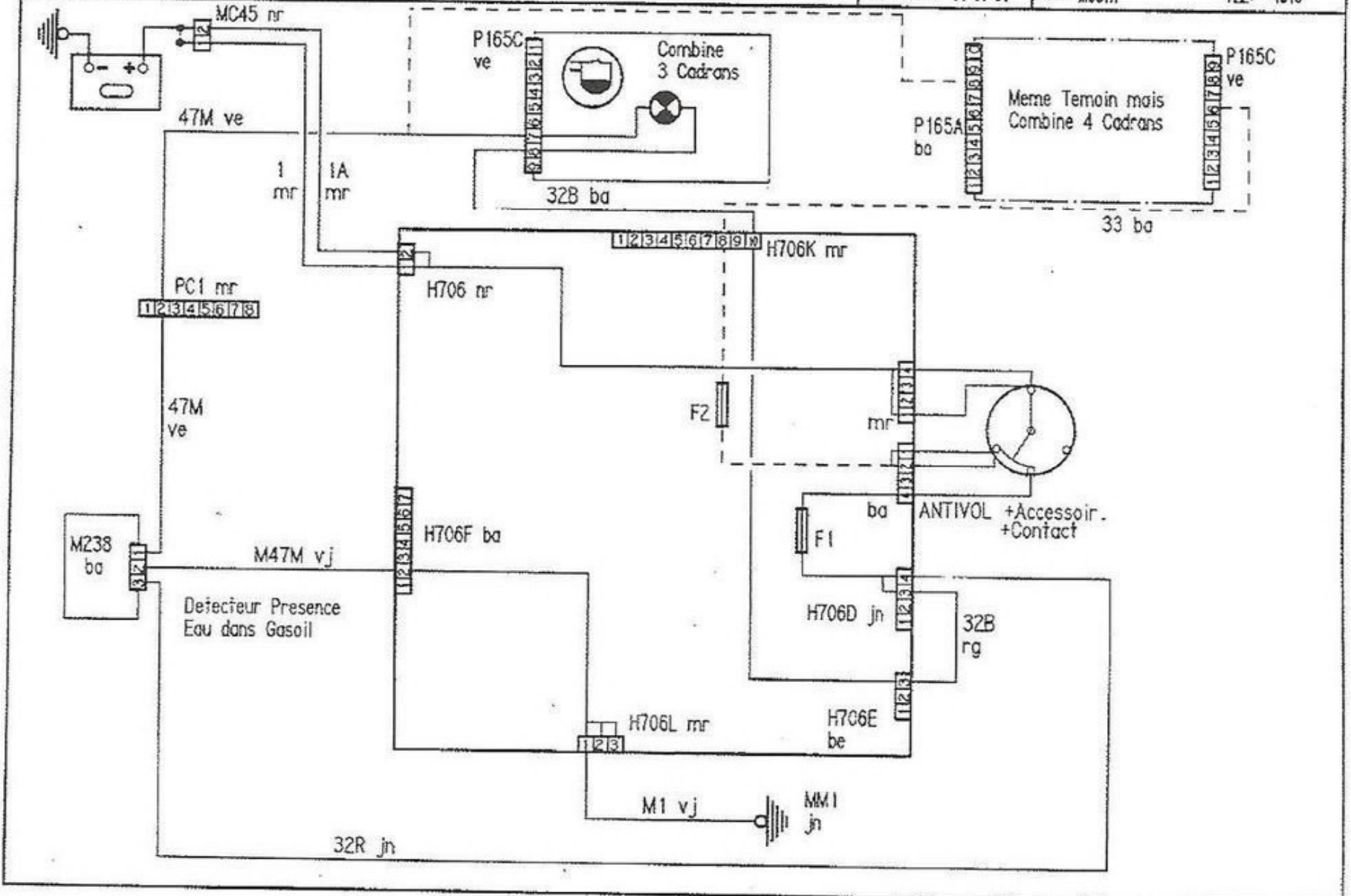

EN POINTILLES : Tous Types Sauf GTI

TYPE CONCERNE:
205 AVEC COMBINE
4 OU 6 CADRANS

RECEPTEURS COMBINE

11/1

A JOUR LE: 01-07-80

NOM: MOUTH

TEL: 4319

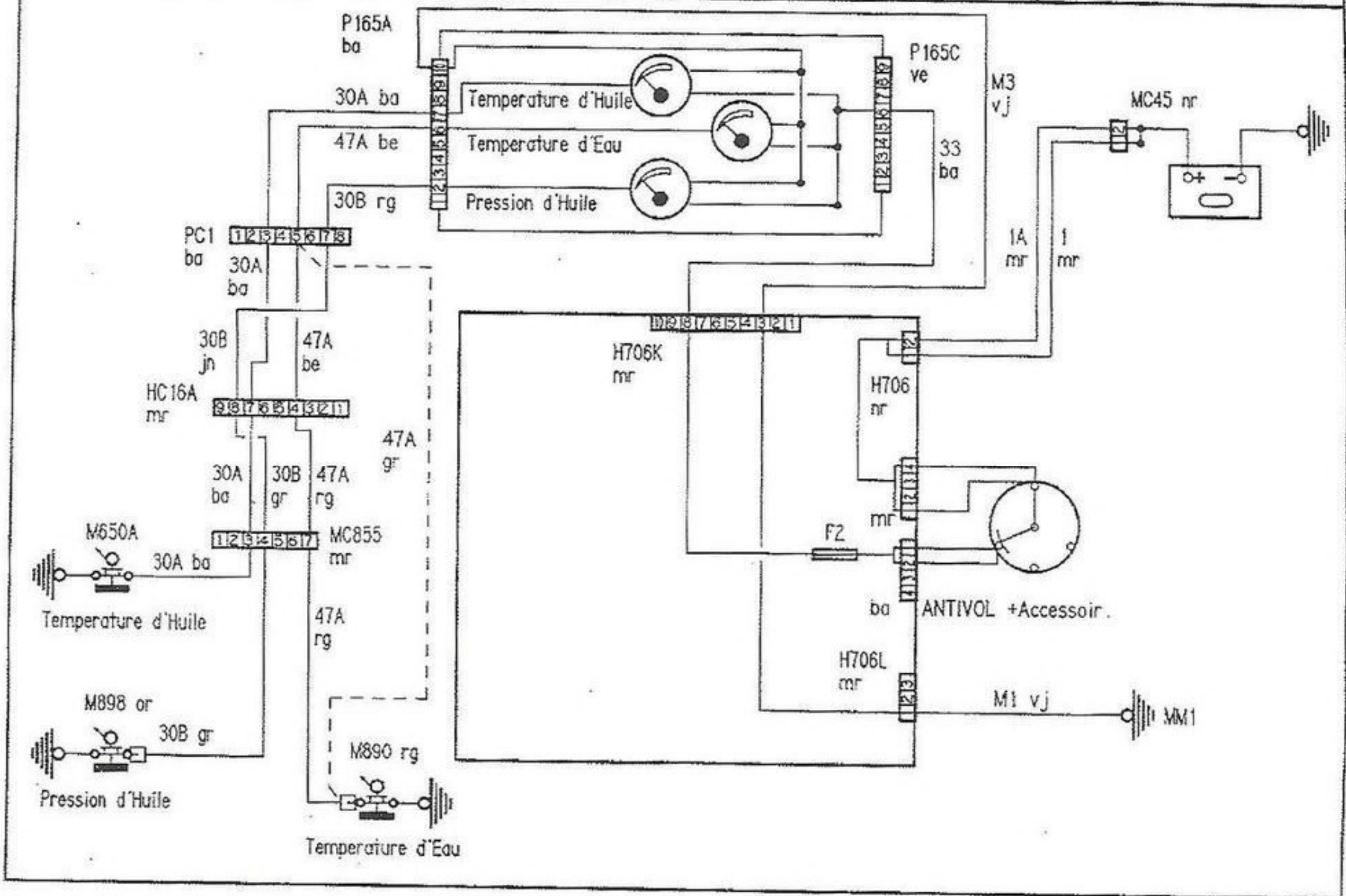

EN POINTILLES:
2 AVERTISSEURS EN GTI 115CV

TYPES CONCERNES:
-205ESS
-205DSL
-205GTI 115CV

AVERTISSEUR

12
1

A JOUR LE: 10-05-88

NOM: VIGNES

TEL: 3162

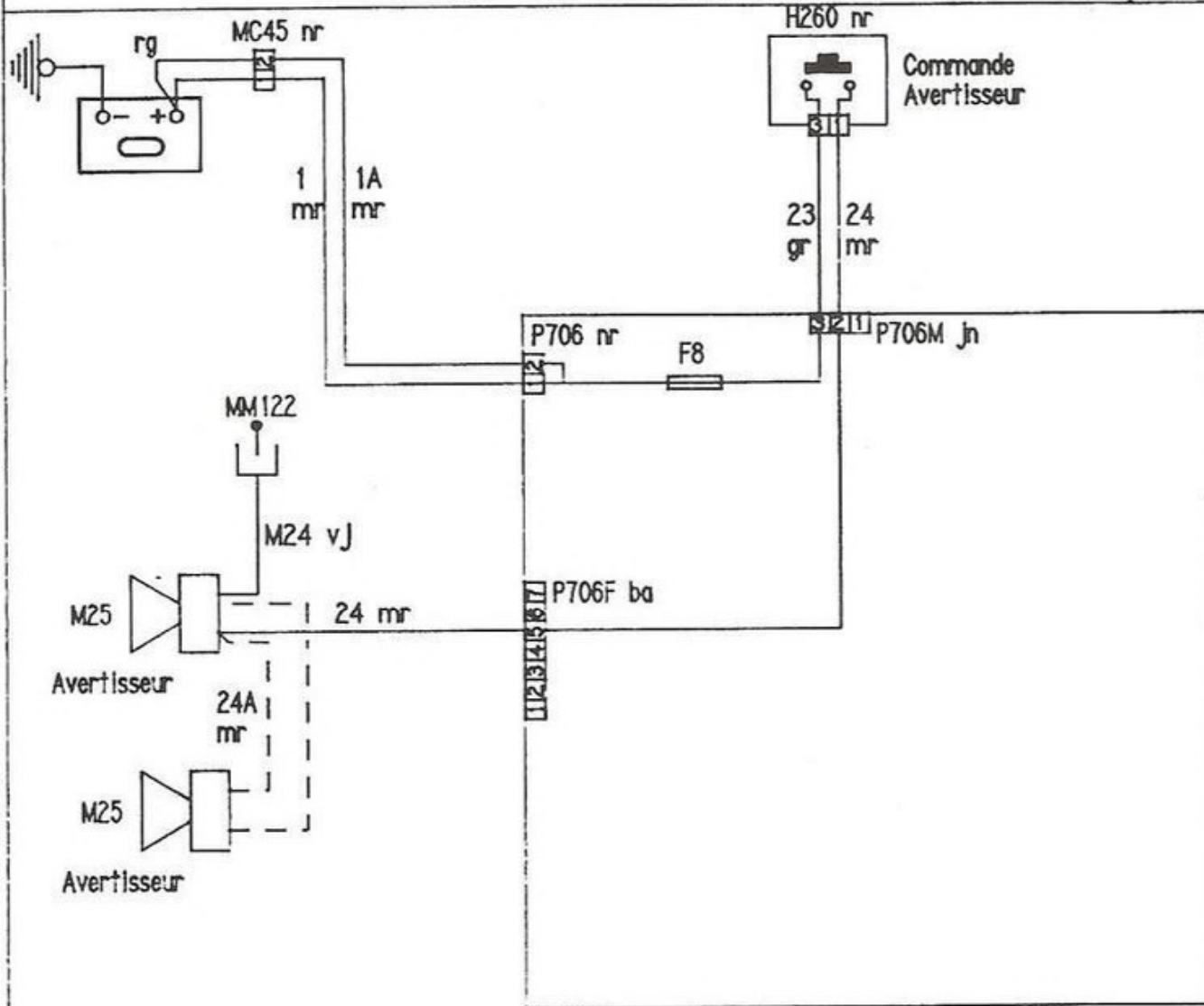

TYPE CONCERNE:
-205GT! 130CV

AVERTISSEUR A COMPRESSION

12
2

A JOUR LE: 01-09-90

NOM: MOUTH

TEL: 4319

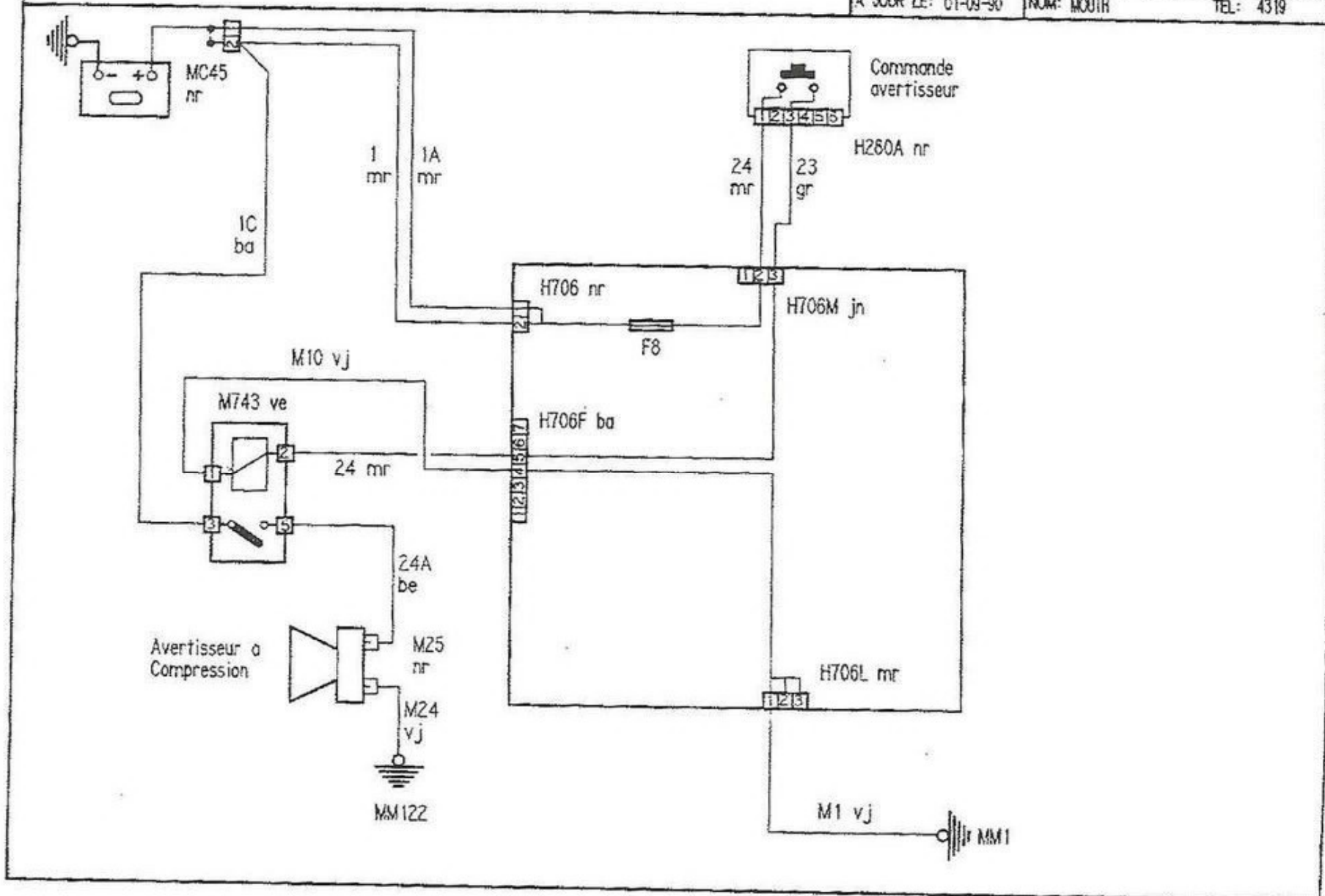

TYPES CONCERNES :
- Direction Droite

FEUX DE POSITION

13
2

A JOUR LE: 01-07-90

NOM: MOUTH

TEL: 4319

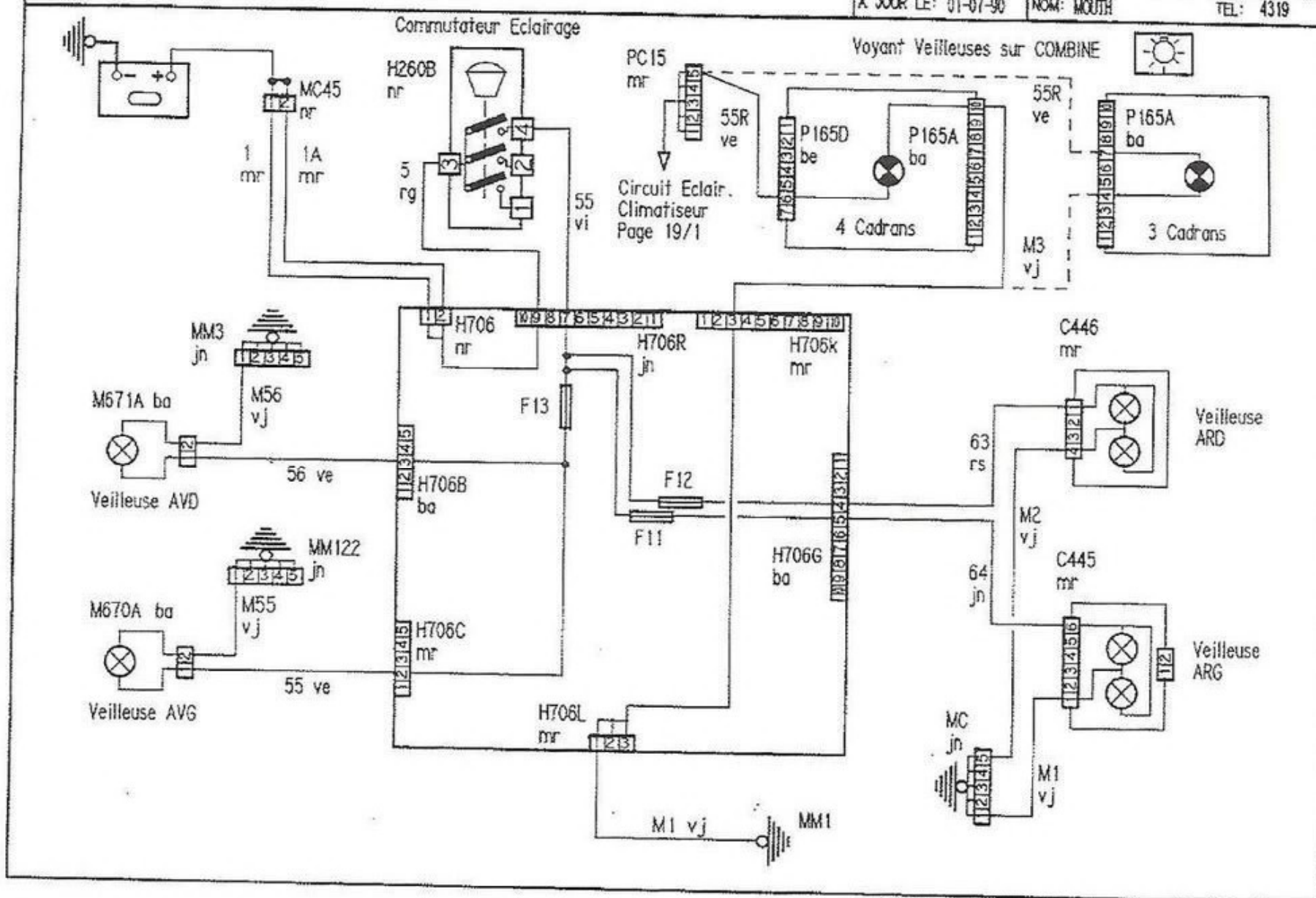

FEUX DE POSITION

13/3

A JOUR LE: 01-09-90

NOM: WOUTH

TEL: 4319

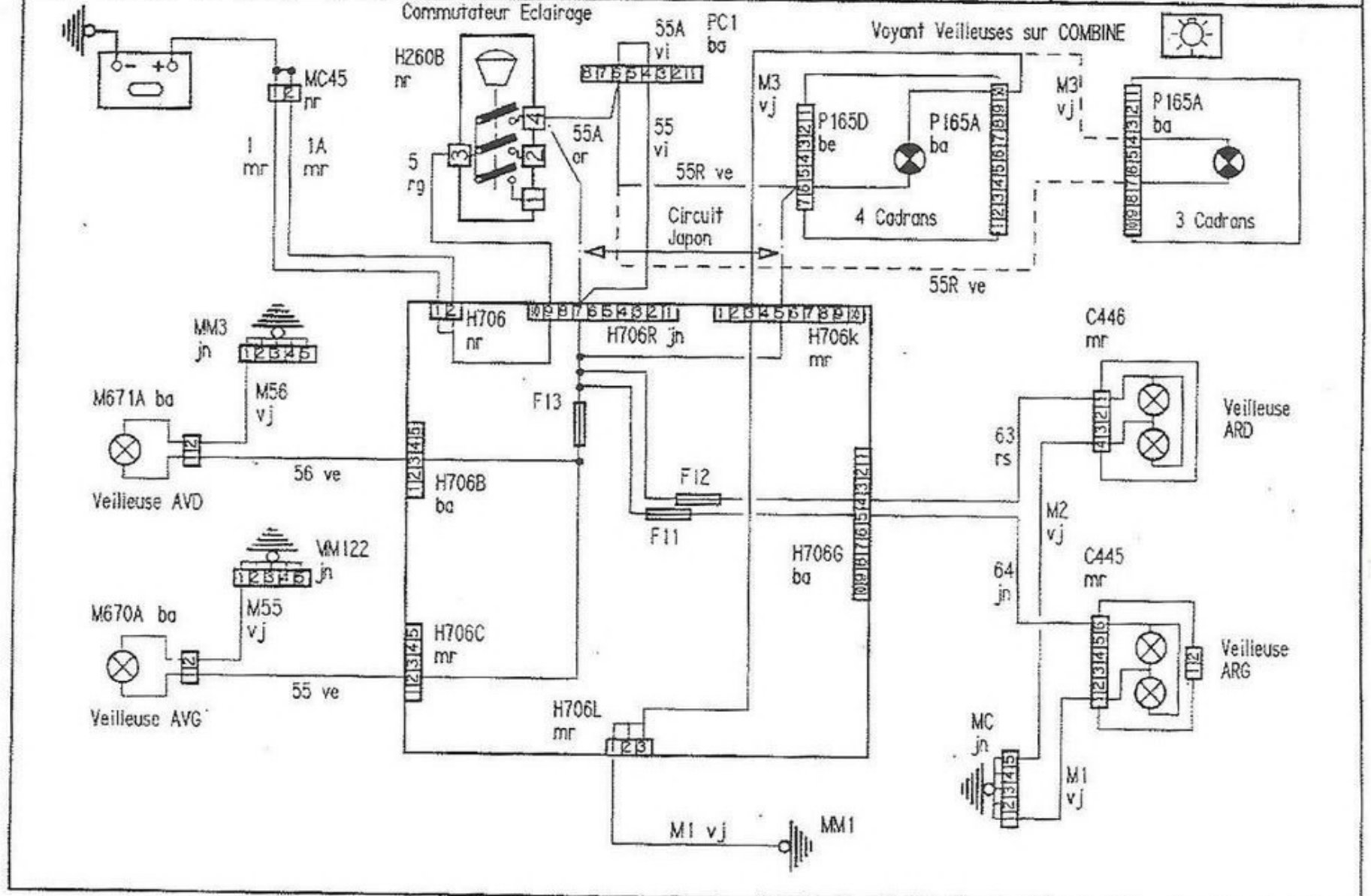

FEUX DE CROISEMENT

14

A JOUR LE: 01-09-90

NOM: MOUTH

TEL: 4319

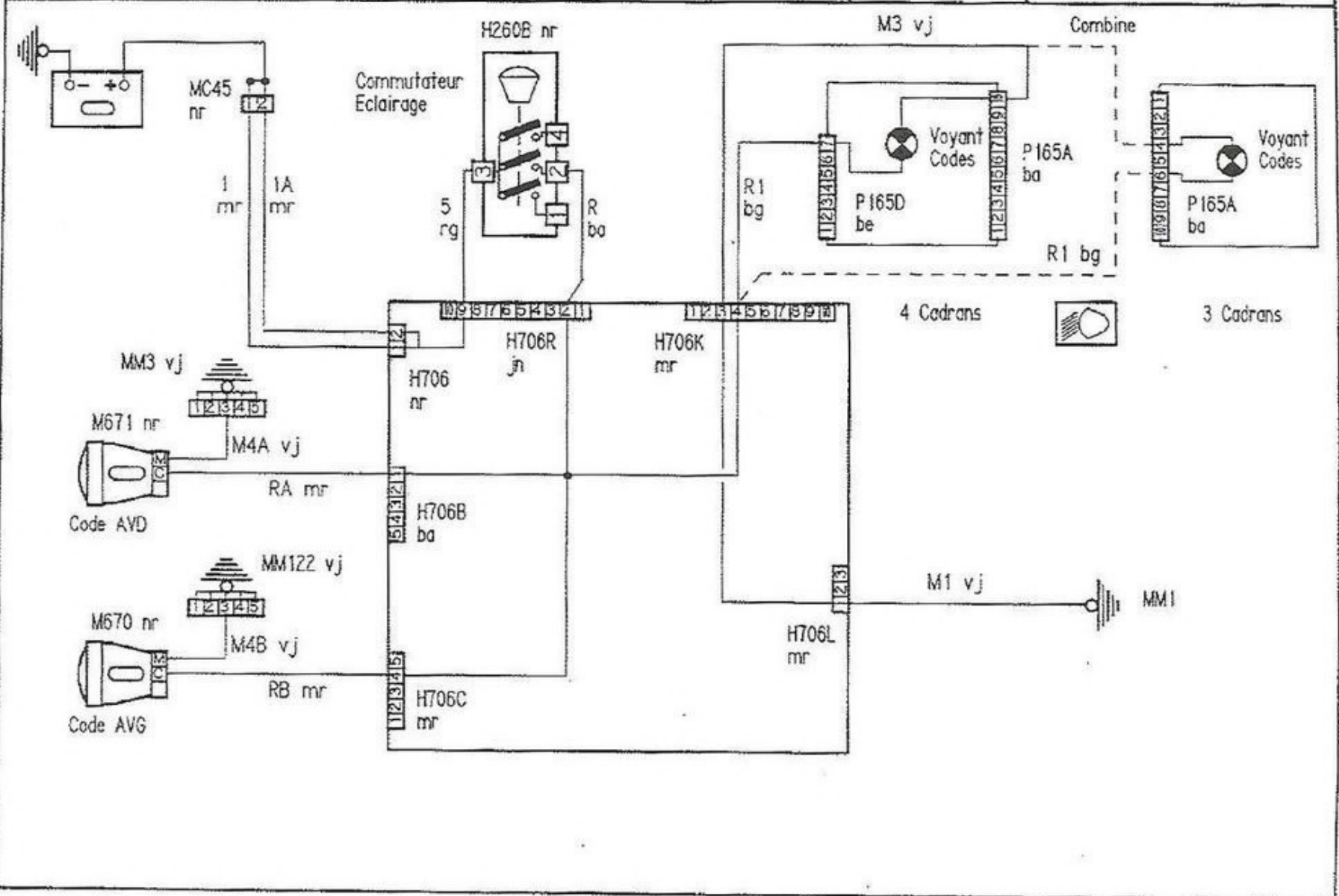

TYPES CONCERNES:
-AVEC COMBINES
3 CADRANS

FEUX DE ROUTE

15
1

A JOUR LE: 01-07-90

NOM: MOUTH

TEL: 4319

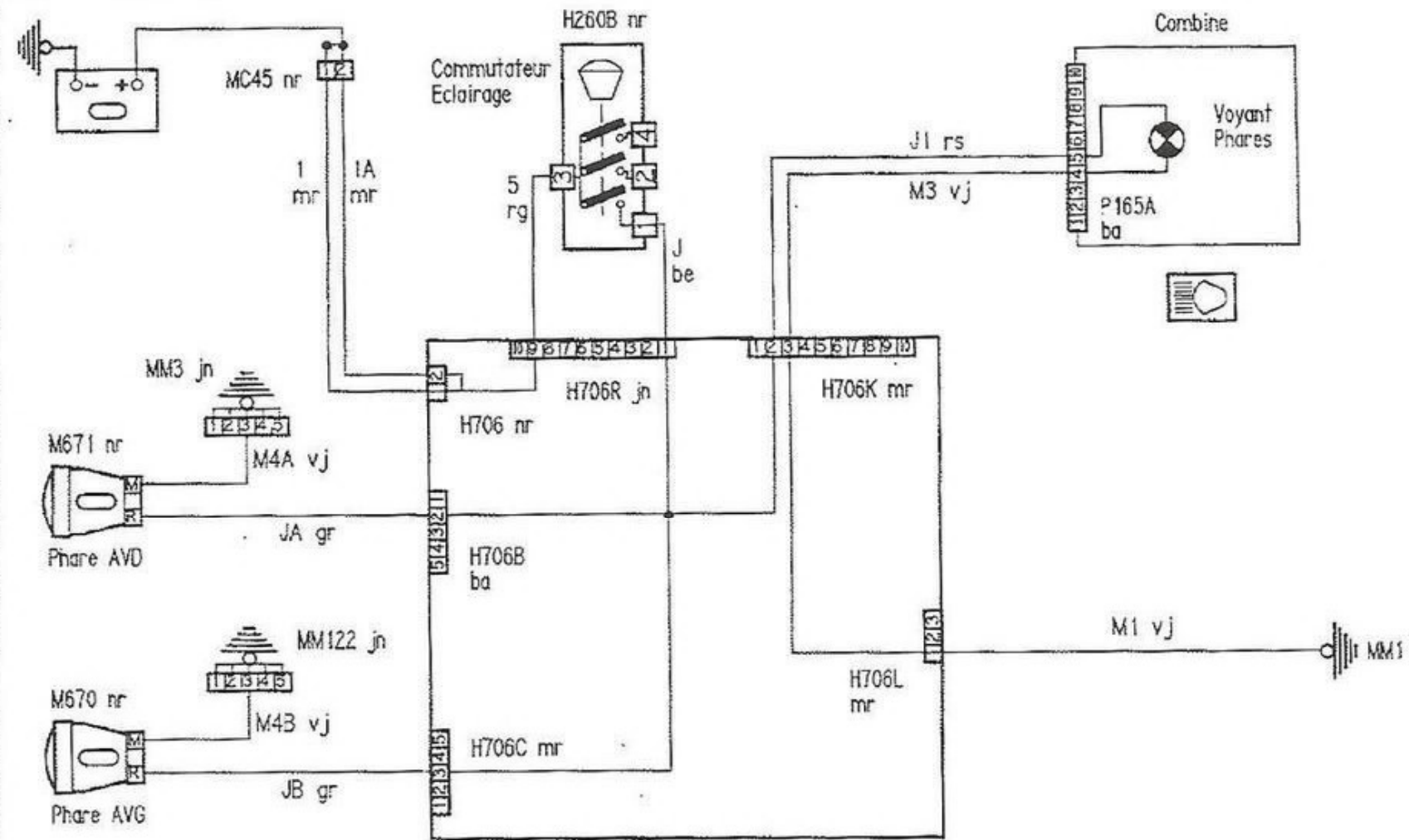

TYPE CONCERNE:
205GTI ET
COMBINE 4 CADRANS

FEUX DE ROUTE
FEUX LONGUE PORTEE

15
2

A JOUR LE: 01-07-90

NOM: MOUTH

TEL: 4319

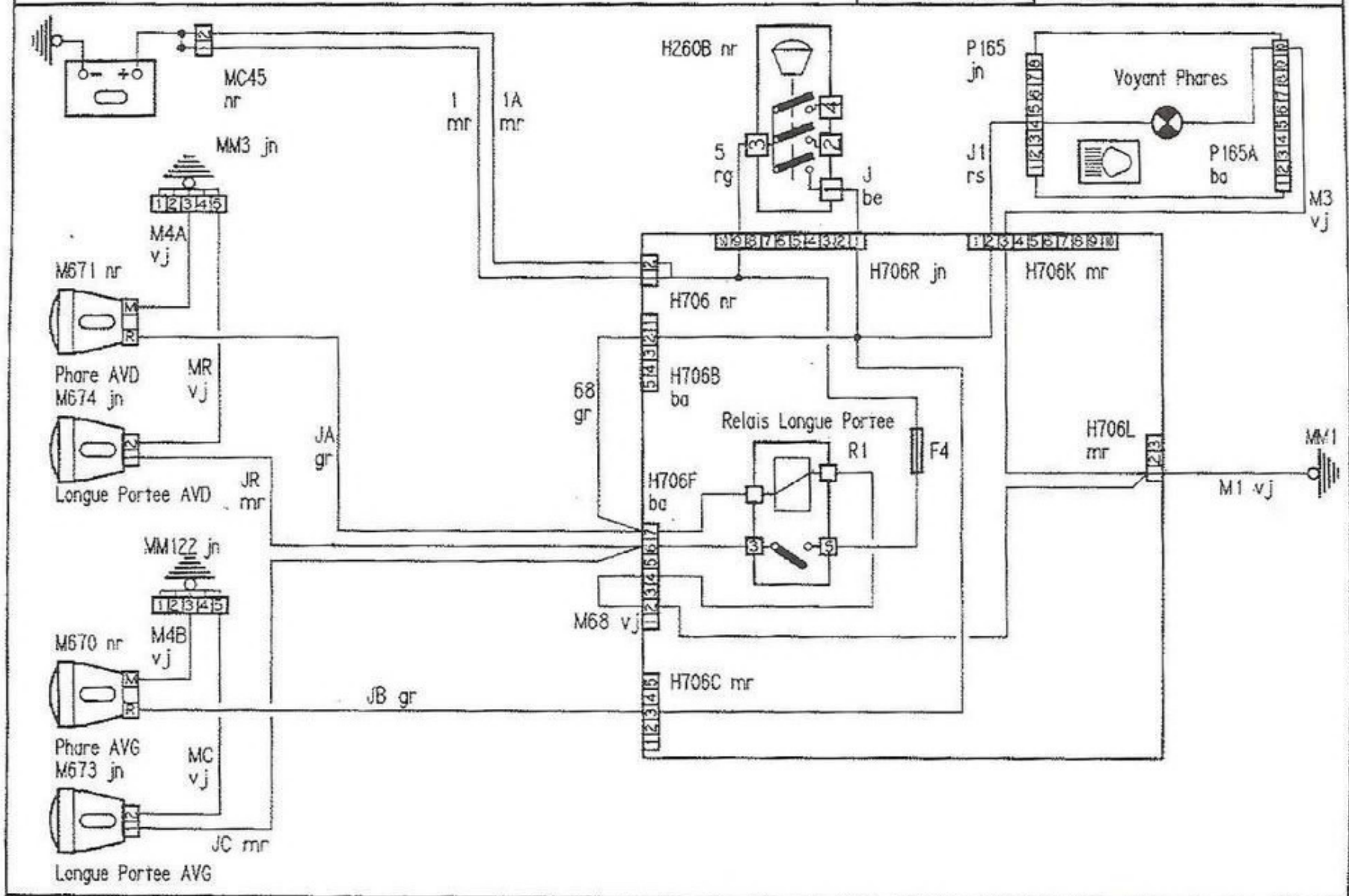

CLIGNOTANTS REPETITEURS

16

A JOUR LE: 01-07-90

NOM: MOUTH

TEL: 4319

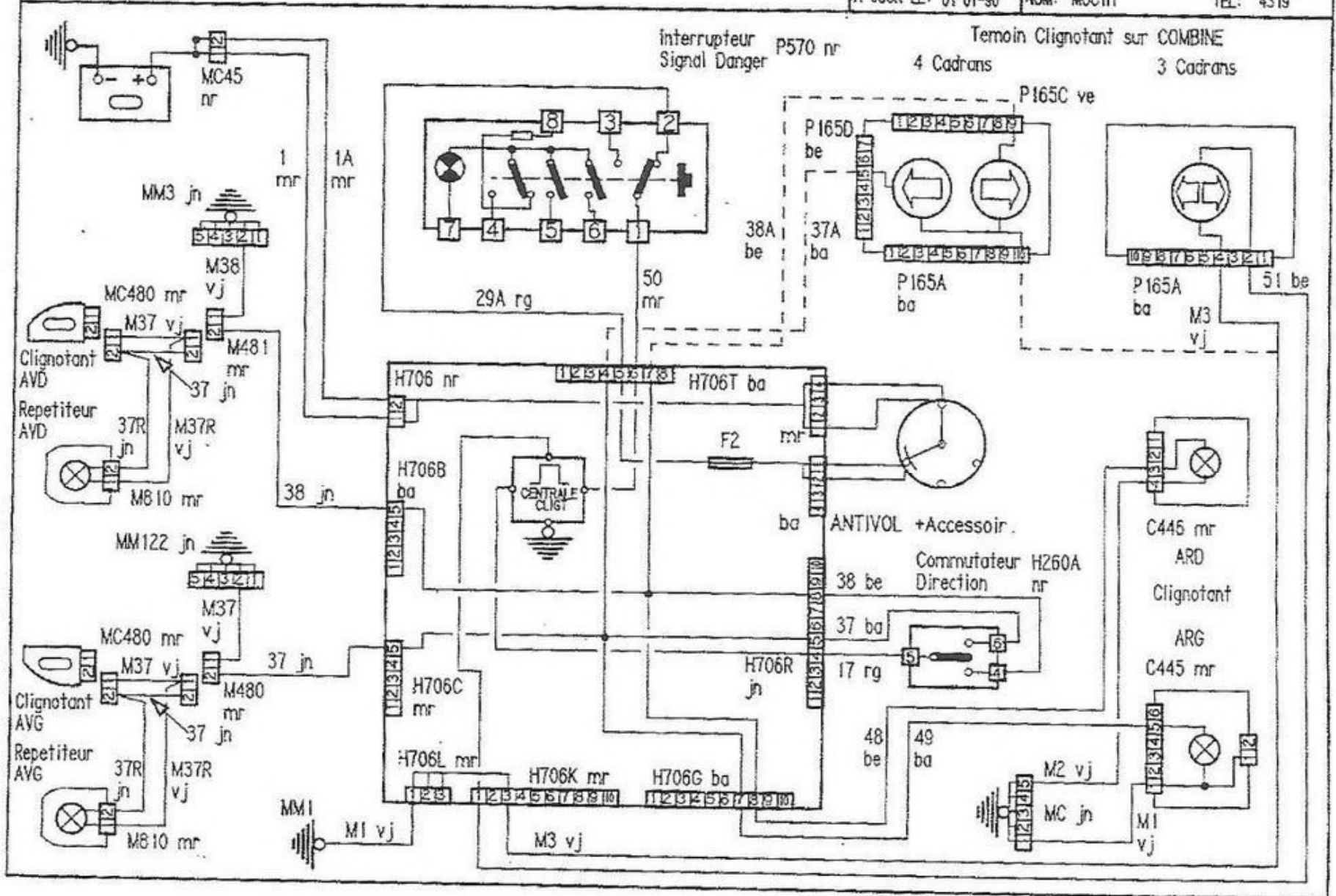

SIGNAL DANGER

17
1

A JOUR LE: 01-07-90 NOM: MOUTH TEL: 4319

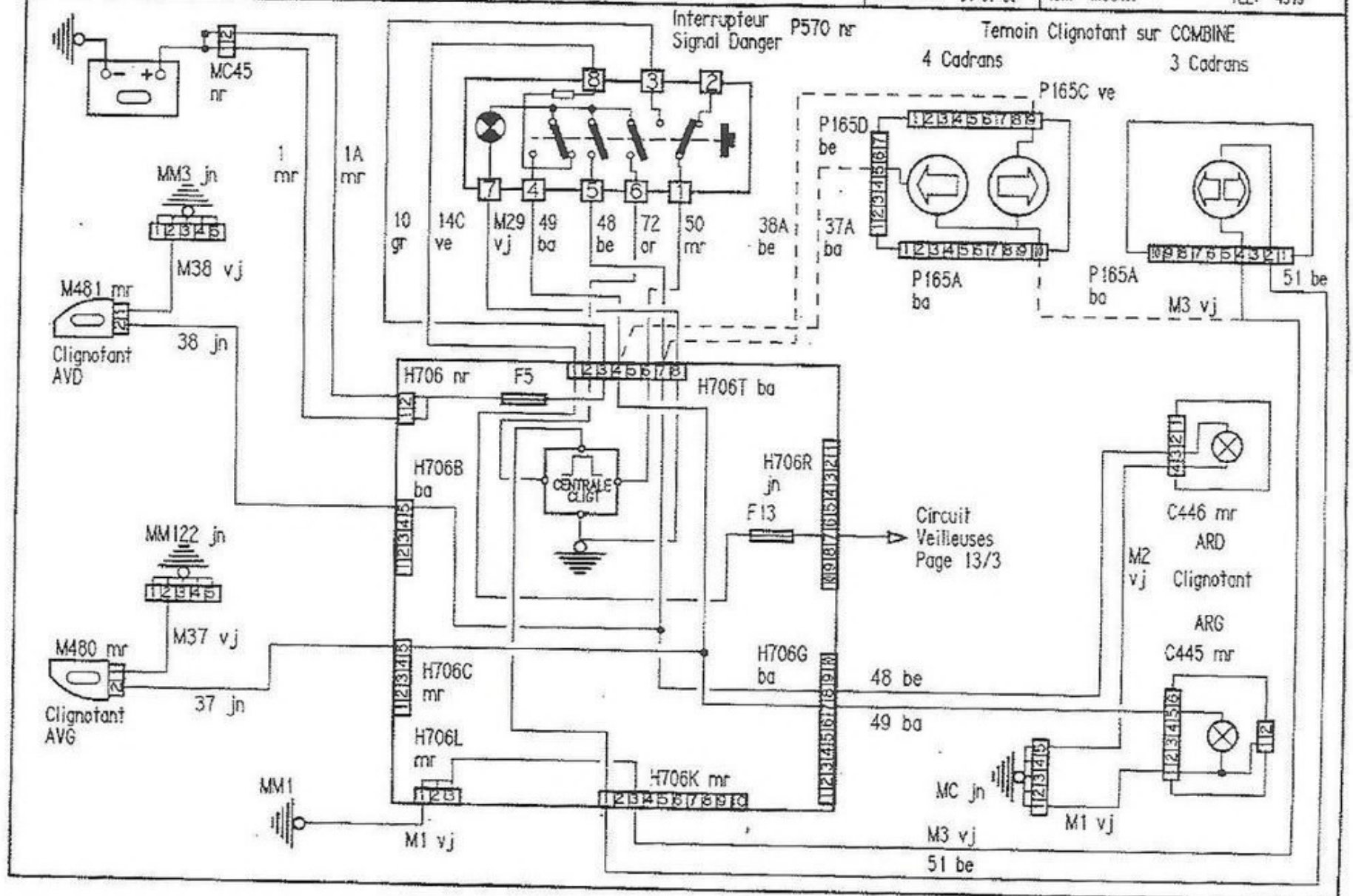

TYPES CONCERNES:
-205ESS
-205DSL

ESSUIE VITRE AVANT NON TEMPORISE

18
1

A JOUR LE: 01-07-90

NOM: MOUTH

TEL: 4319

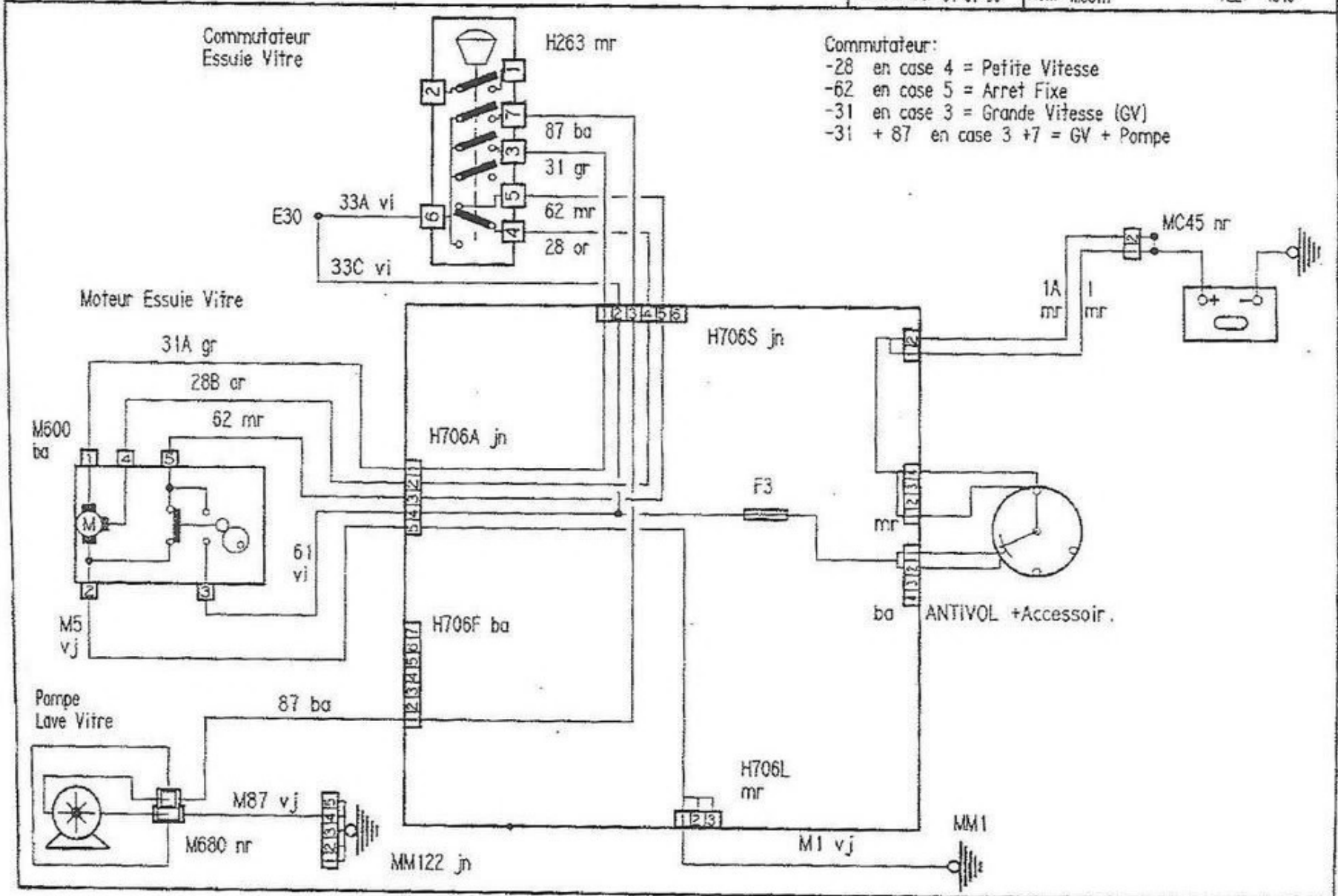

Commutateur:
-28 en case 4 = Petite Vitesse
-62 en case 5 = Arrêt Fixe
-31 en case 3 = Grande Vitesse (GV)
-31 + 87 en case 3 +7 = GV + Pompe

TYPES CONCERNES:
 -205ESS
 -205DSL
 -205GTI

ESSUIE VITRE AVANT TEMPORISE

18
 2

A JOUR LE: 01-07-90

NOM: MOUTH

TEL: 4319

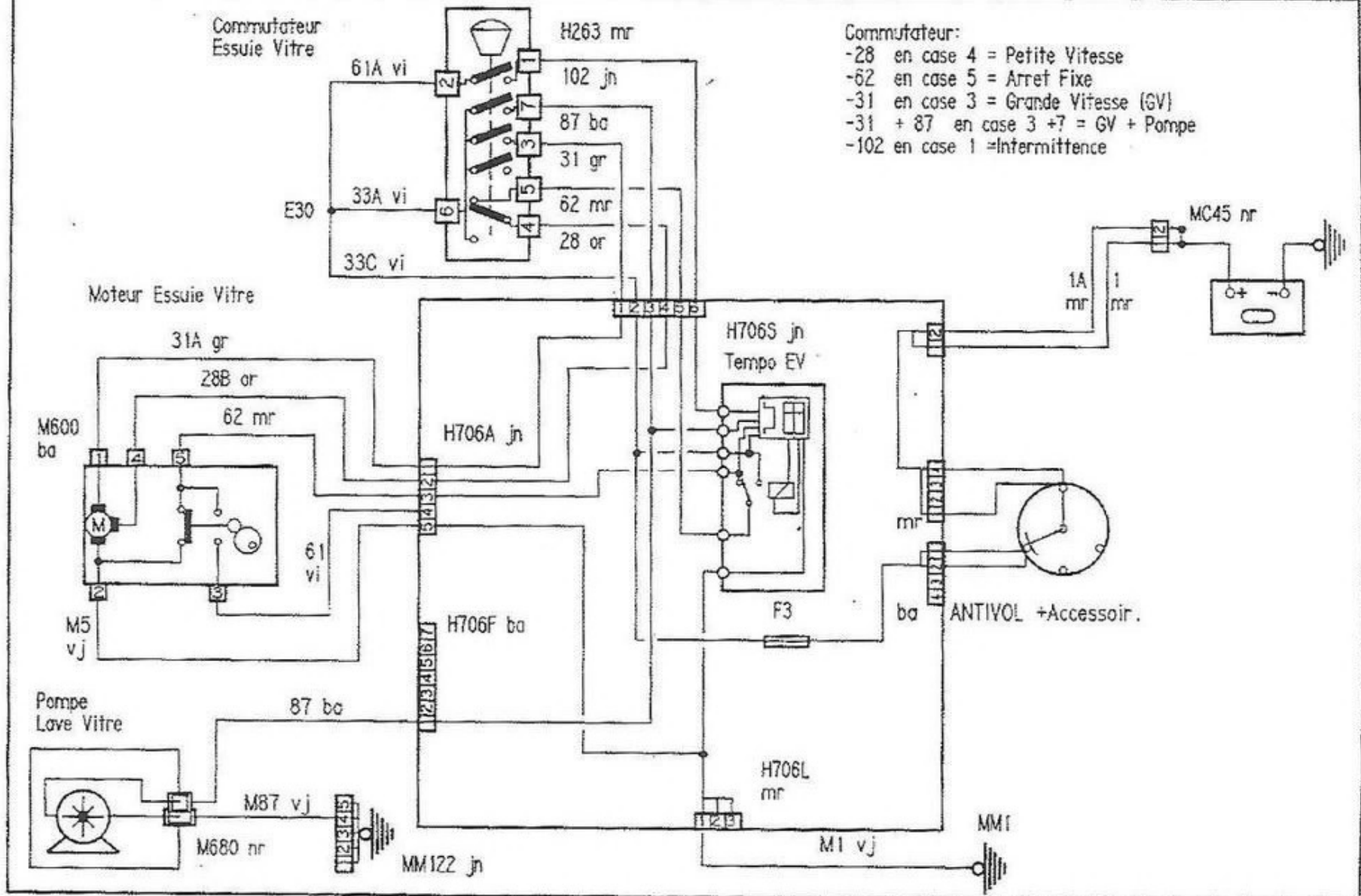

TYPES CONCERNES:
- 205 Direction Droite

ECLAIRAGE : FACADE
CLIMATIS. et COMBINE

19
1

A JOUR LE: 01-09-90

NOM: MOUTH

TEL: 4319

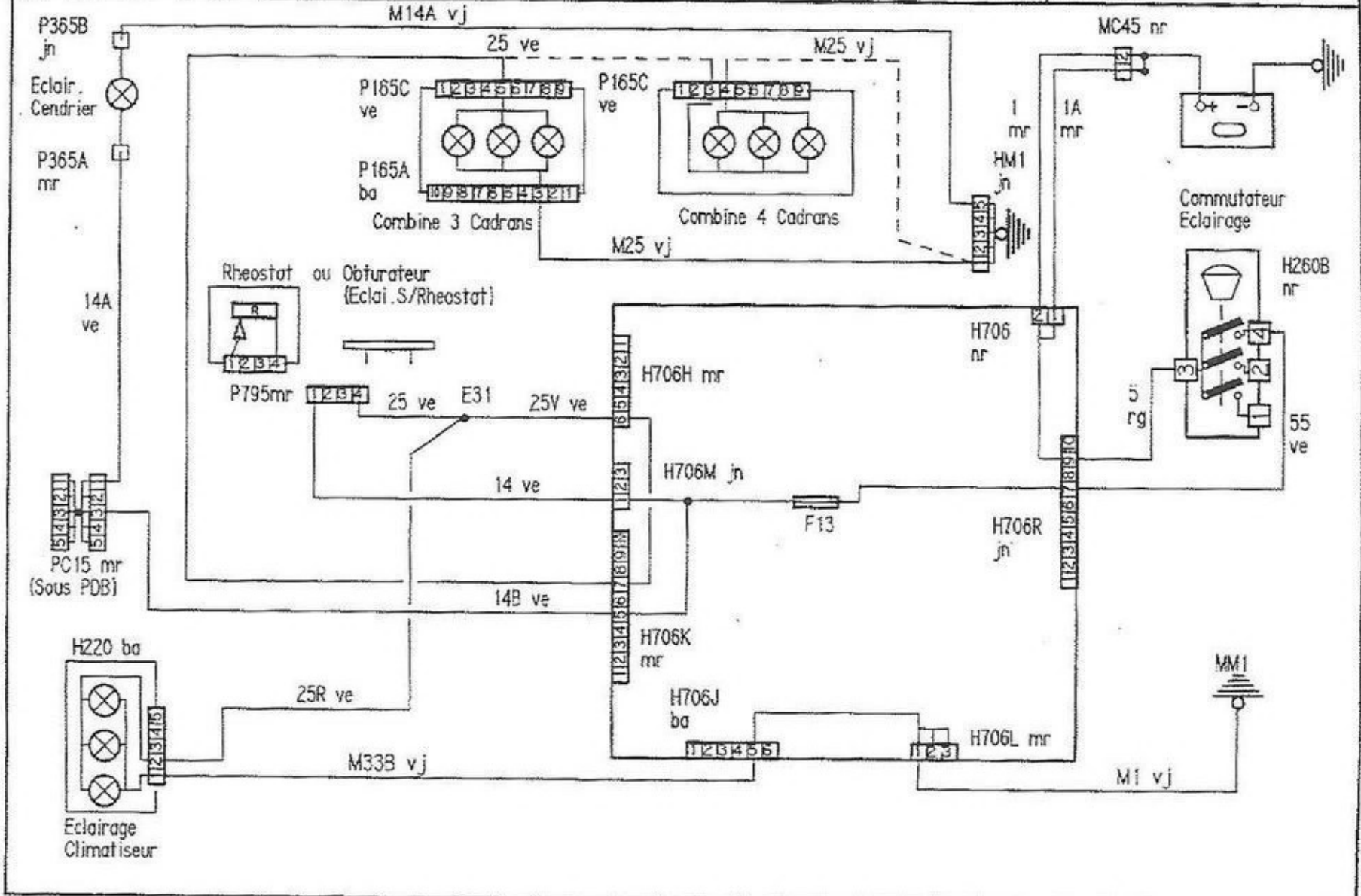

ECLAIRAGE : FACADE CLIMATIS. et COMBINE

19 / 2

A JOUR LE: 01-07-90 NOM: MOUTH TEL: 4319

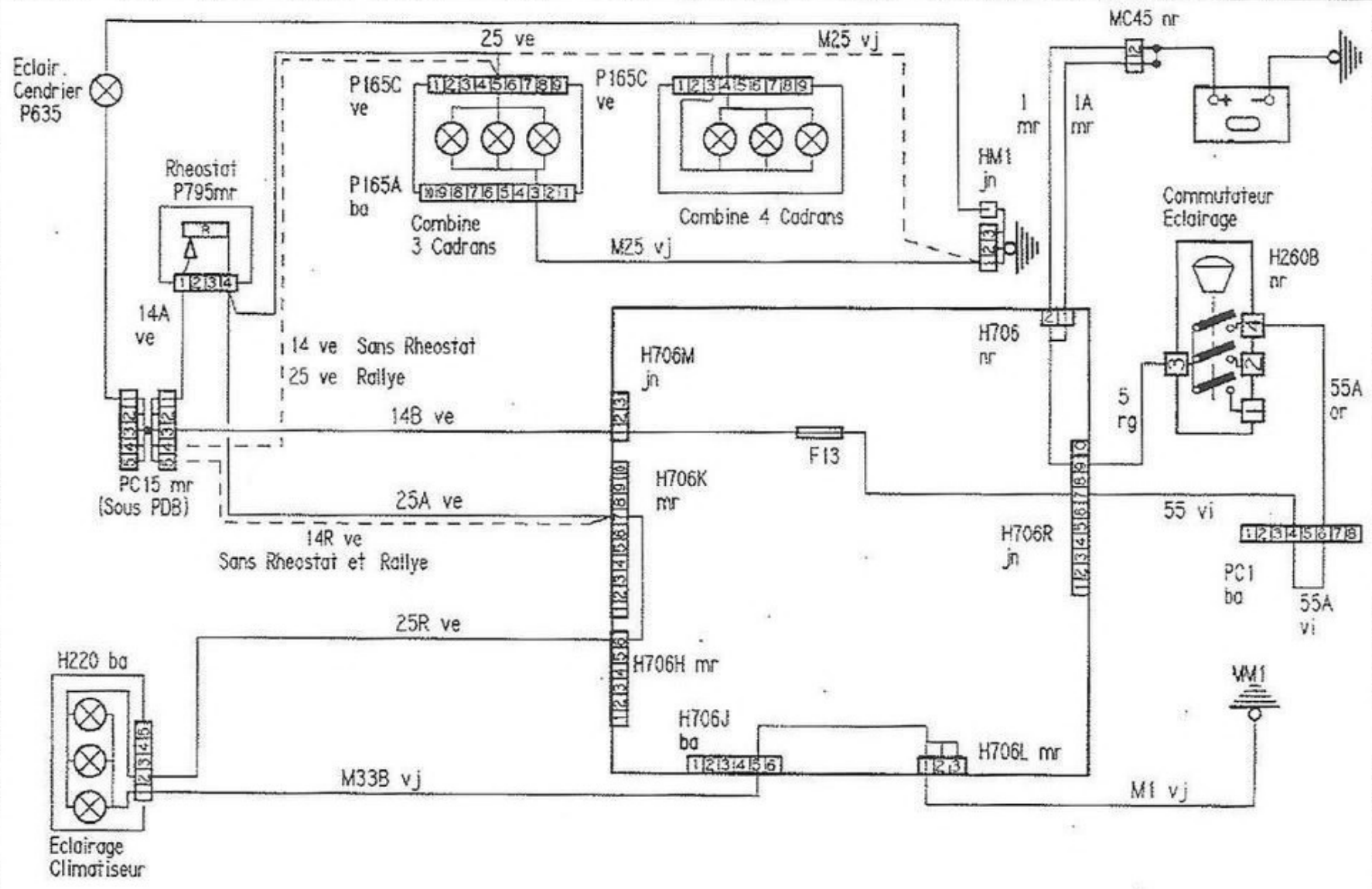

TYPES CONCERNES:
-205 AVEC COMBINES
3 + 4 CADRANS

MONTRE AIGUILLES

20

A JOUR LE: 01-07-90

NOM: MOUTH

TEL: 4319

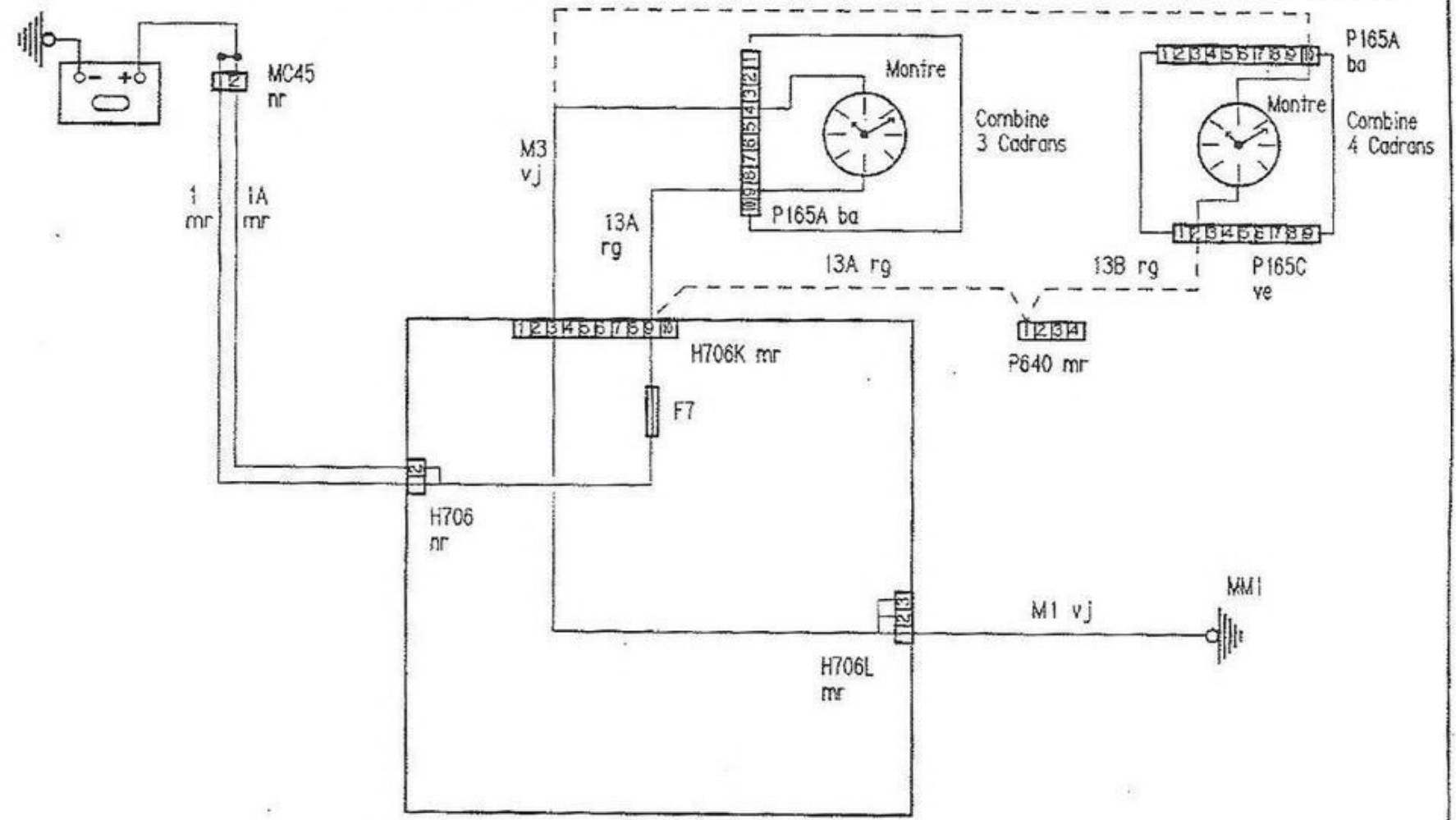

EN POINTILLES : Direction a Droite

MONTRE DIGITALE

20
2

A JOUR LE: 01-09-90

NOM: MOUTH

TEL: 4319

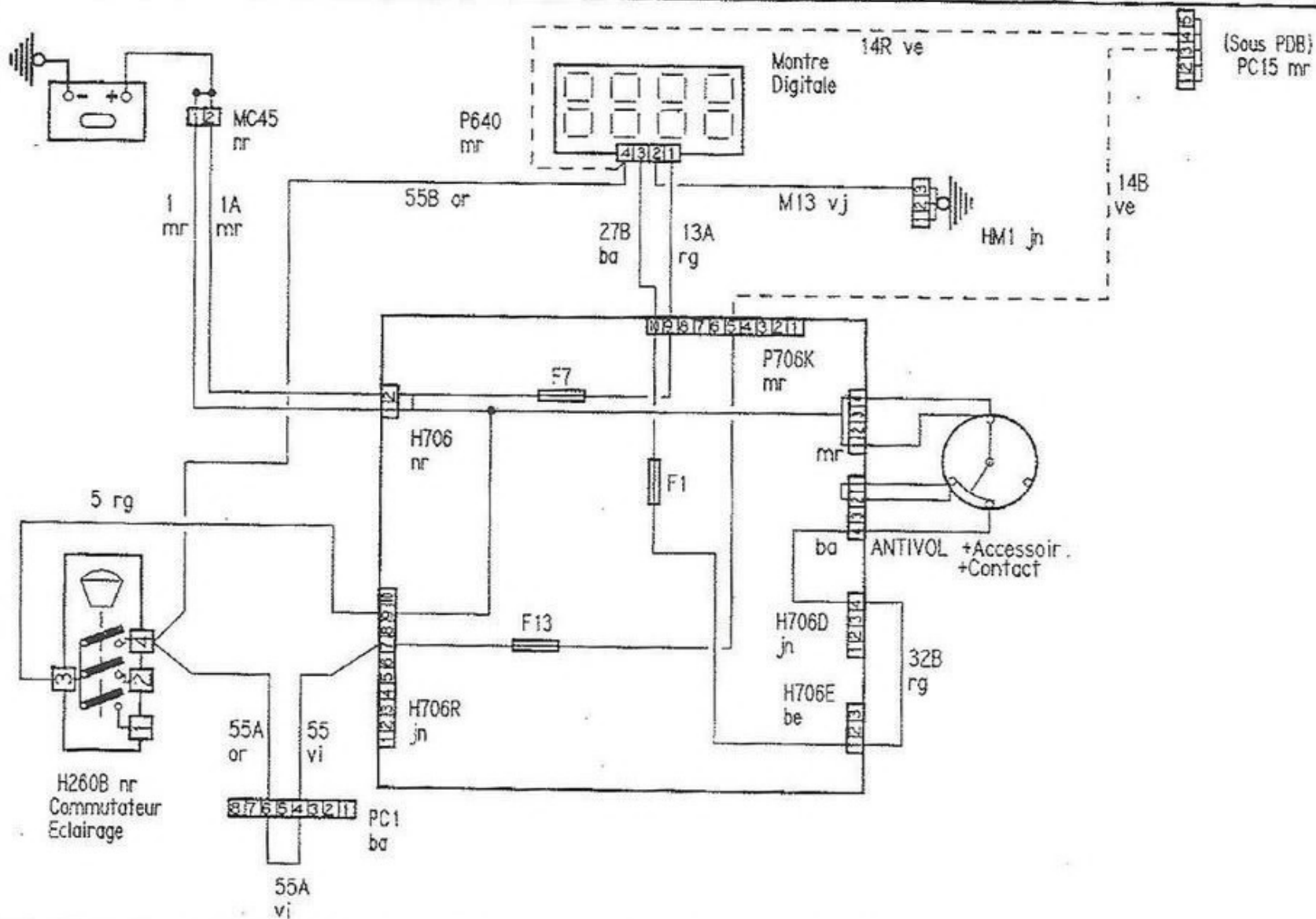

TYPES CONCERNES:
-205ESS
-205DSL
-205GTI

CLIMATISEUR

21
1

A JOUR LE: 01-07-90

NOM: MOUTH

TEL: 4319

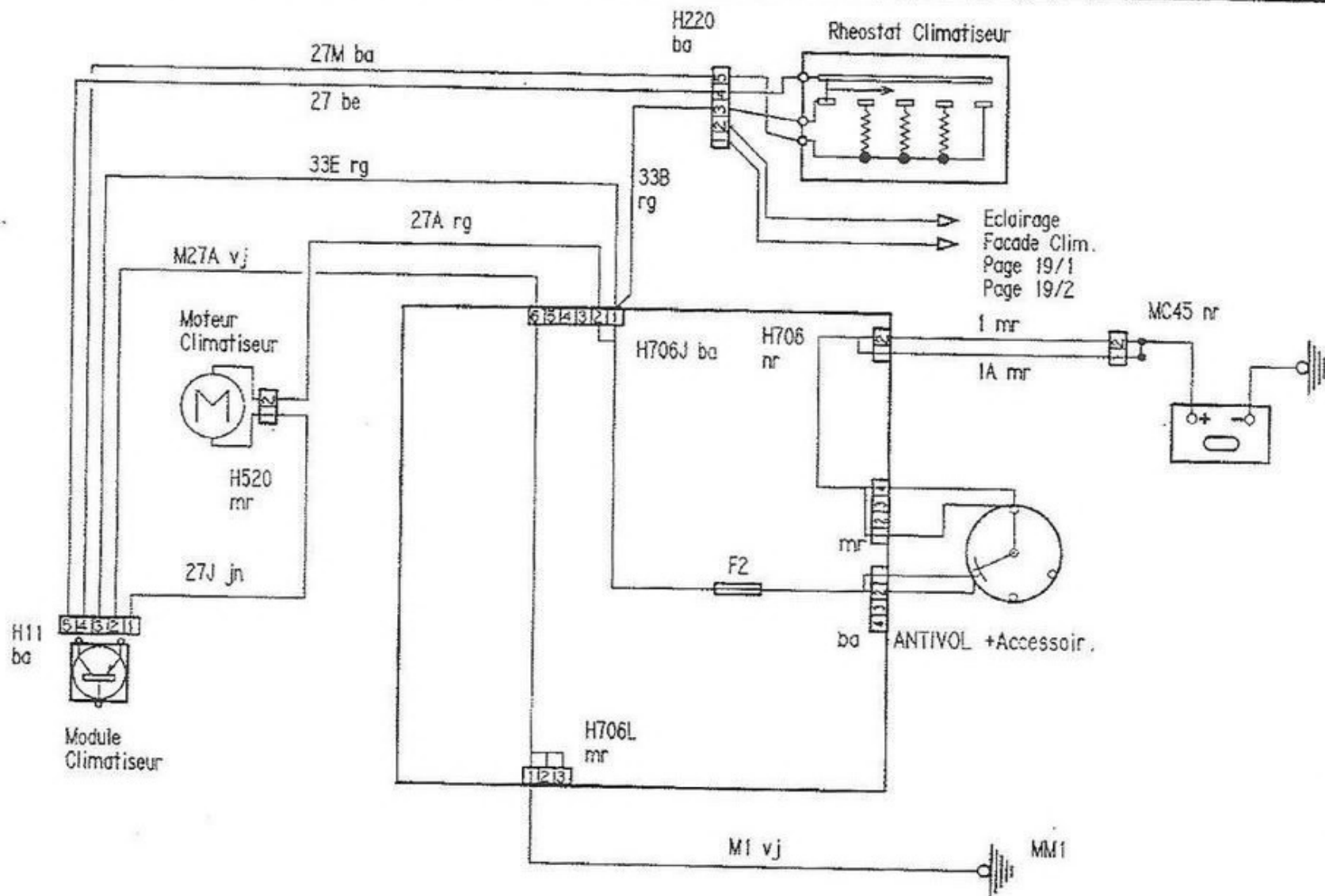

EN POINTILLES : Direction Droite

ALLUME CIGARE

22
1

A JOUR LE: 01-07-90

NOM: MOUTH

TEL: 4319

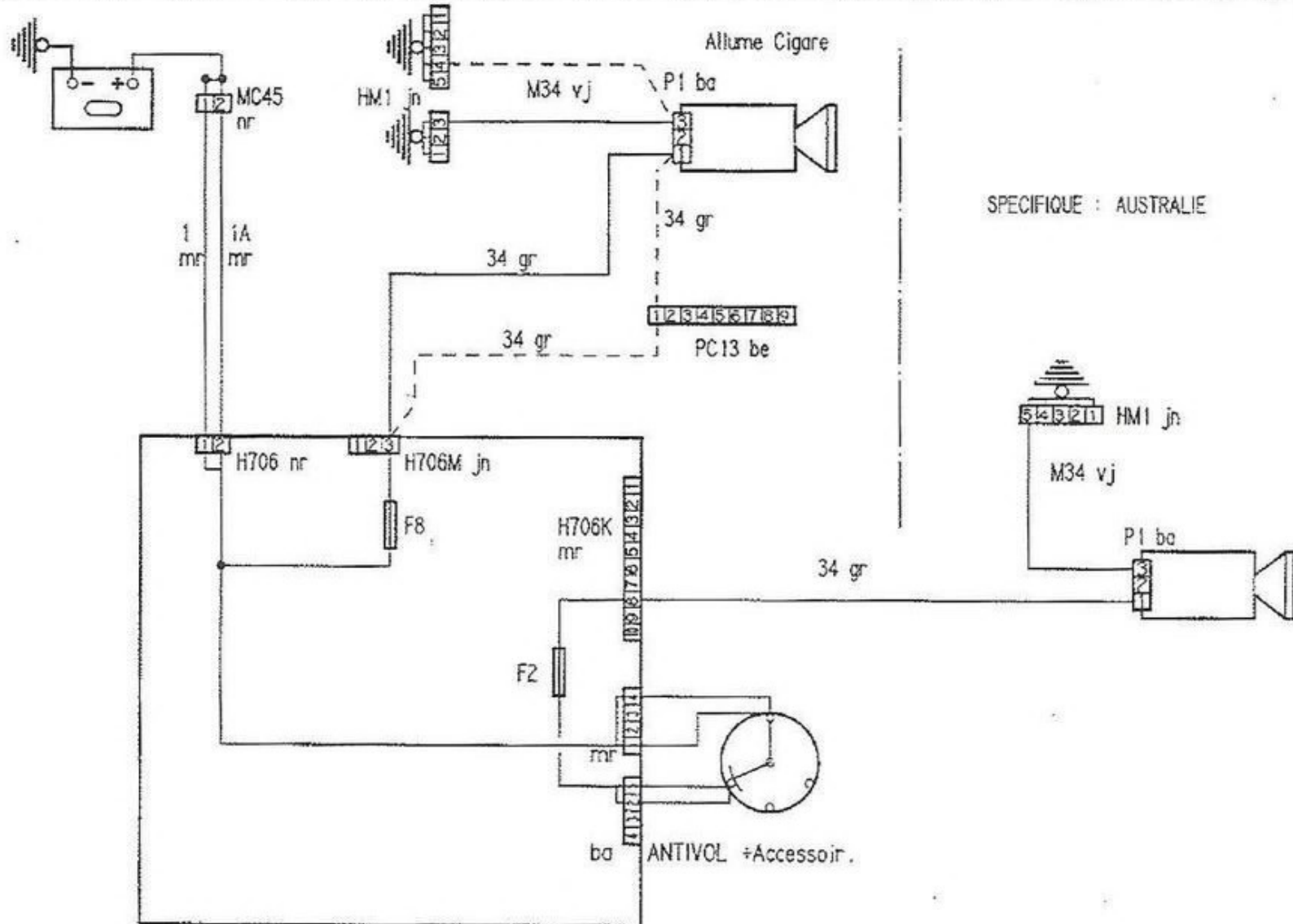

ALIMENT. AUTO RADIO HAUT PARLEURS

A JOUR LE: 01-09-90 NOM: MOUTH TEL: 4319

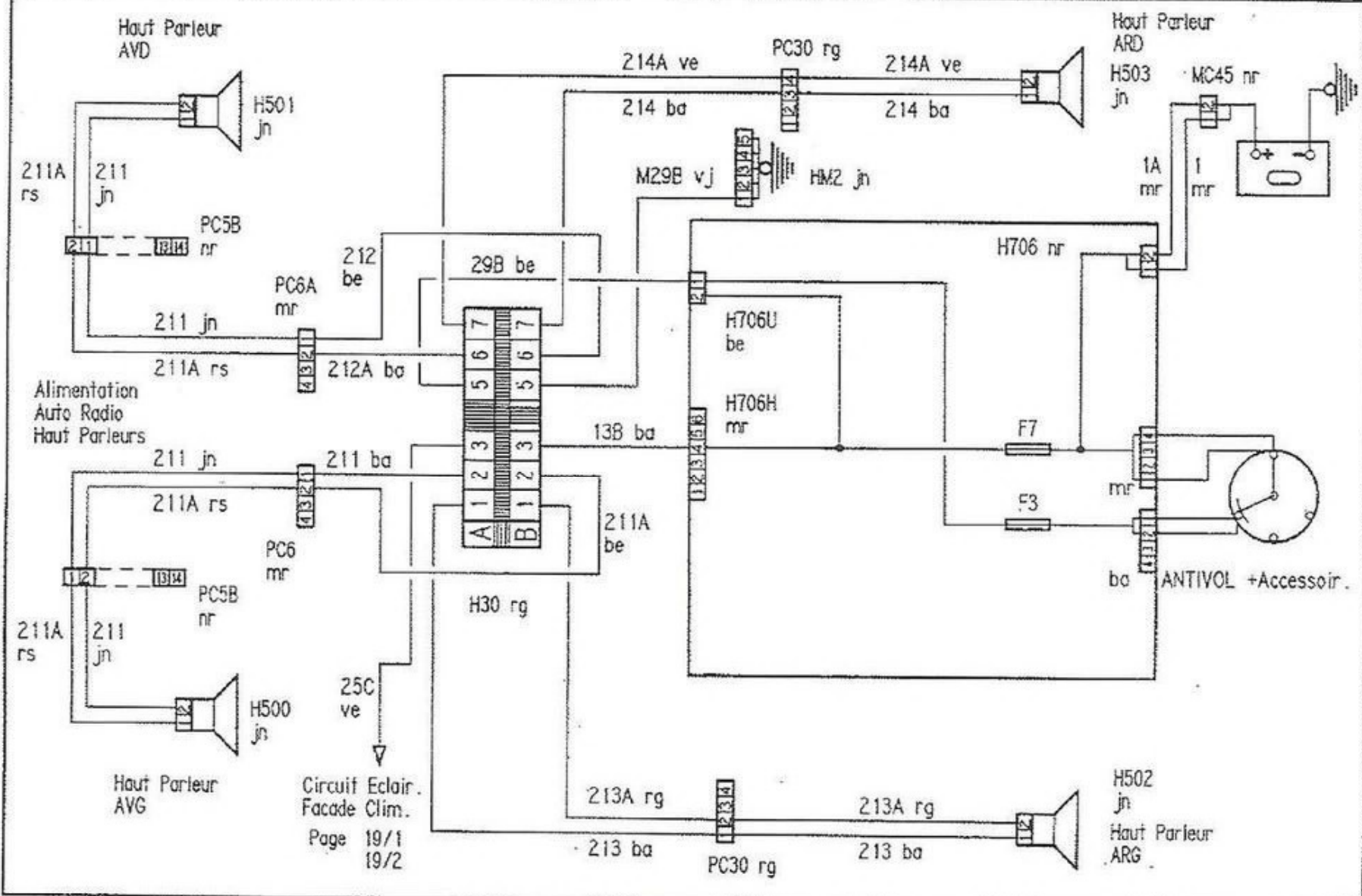

Circuit Eclair. Facade Clim.
Page 19/1
19/2

PLAFONNIER LECTEUR DE CARTES

25
1

A JOUR LE: 01-09-90

NOM: MOUTH

TEL: 4319

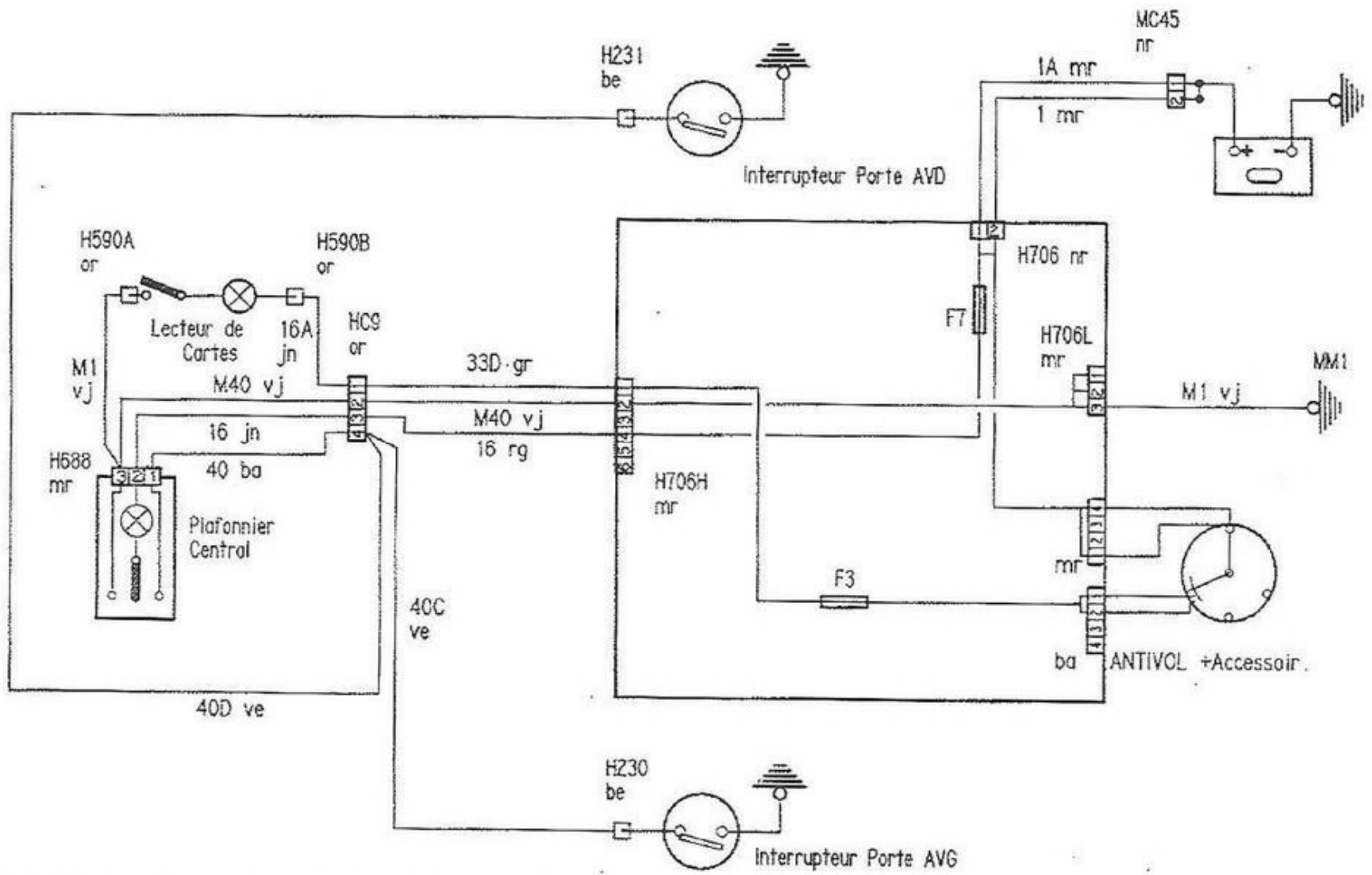

PLAFONNIER - PLIP LECTEUR DE CARTES

25
2

A JOUR LE: 01-09-90

NOM: MOUTH

TEL: 4319

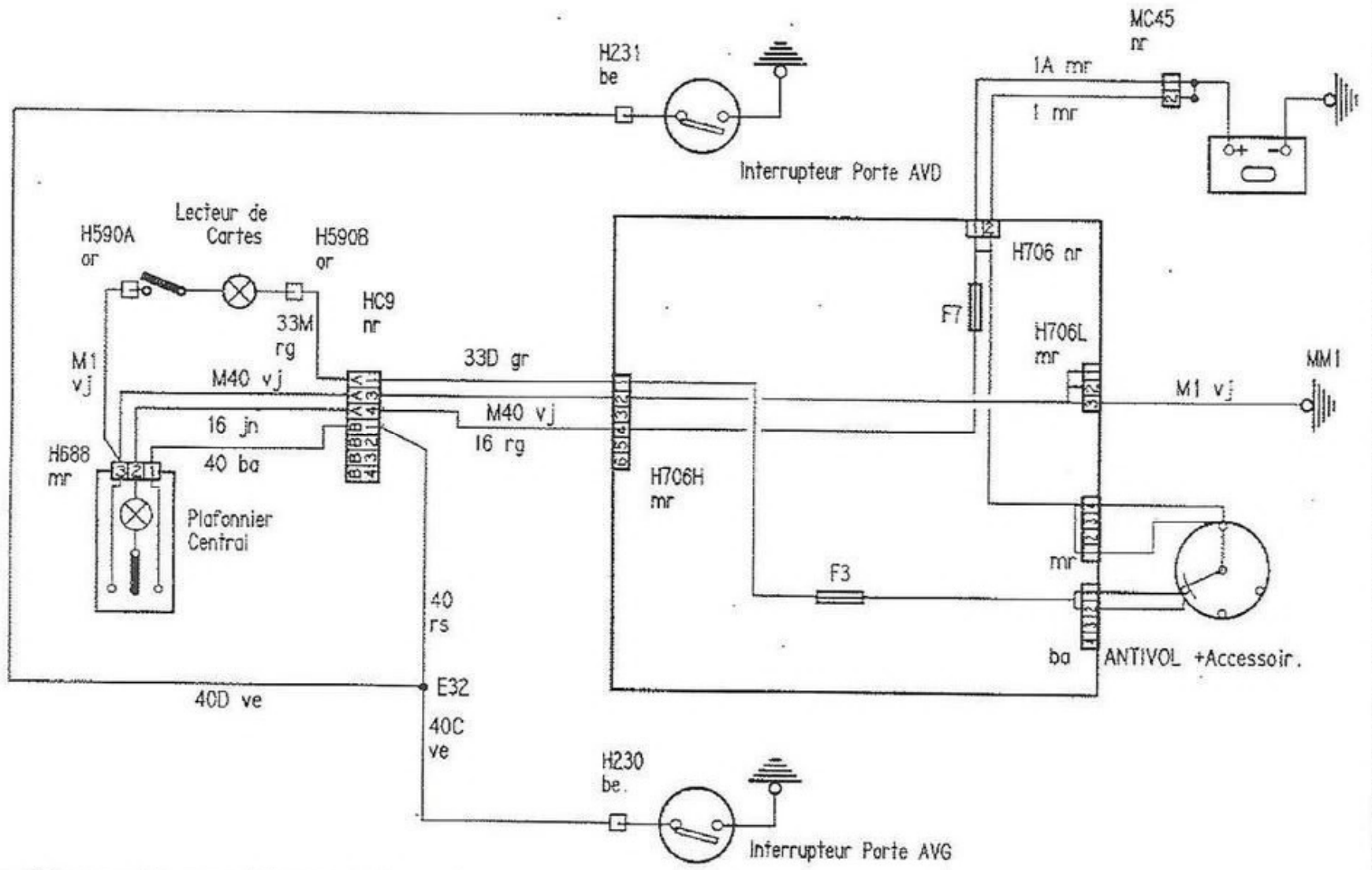

TEMPO PLAFON PLIP
PARE SOLEIL ECLAIR.

25
3

A JOUR LE: 01-09-90

NOM: MOUTH

TEL: 4319

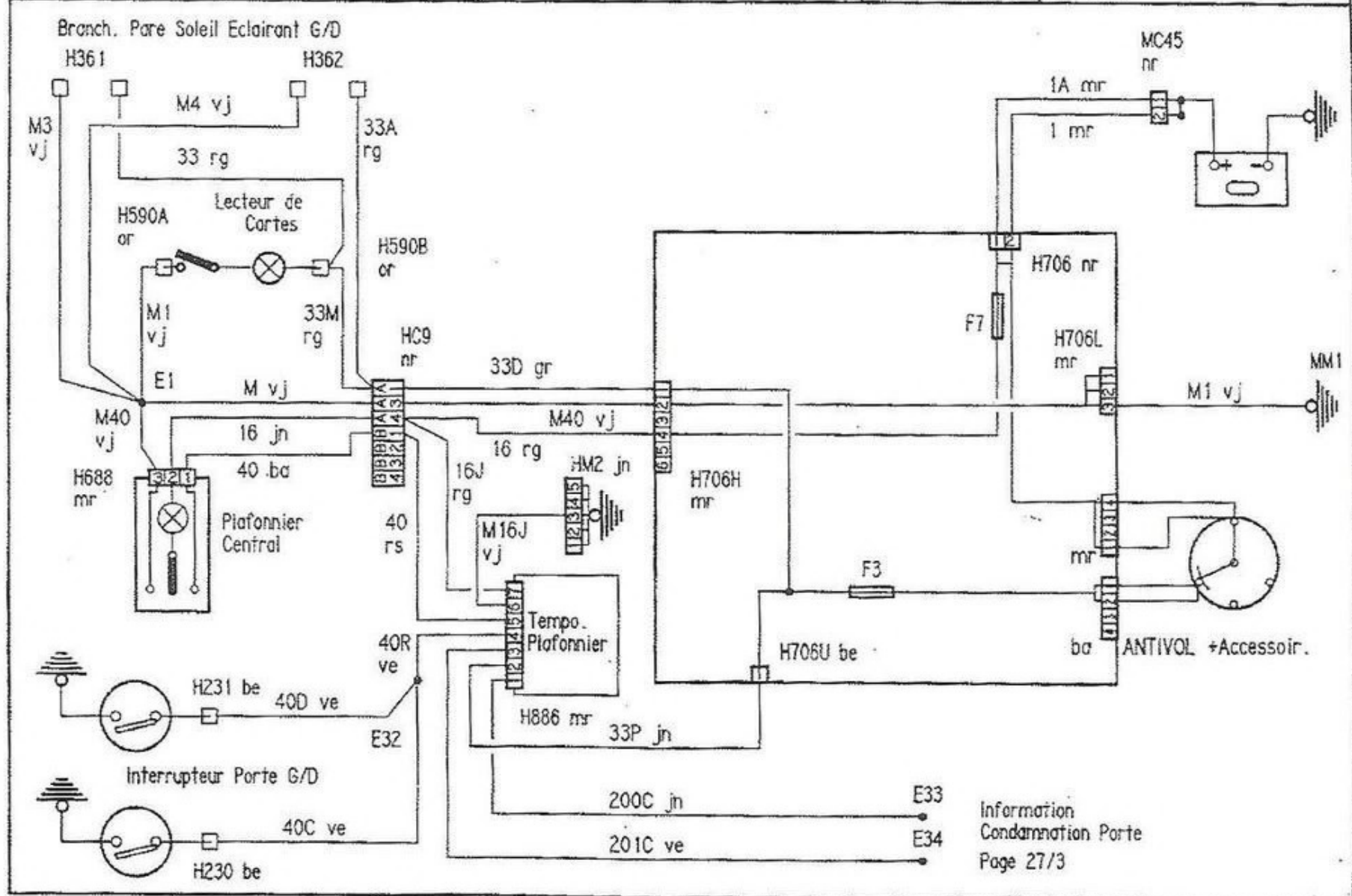

EN POINTILLES : Direction a Droite

ECLAIRAGE VIDE POCHE

25
5

A JOUR LE: 01-07-90

NOM: MOUTH

TEL: 4319

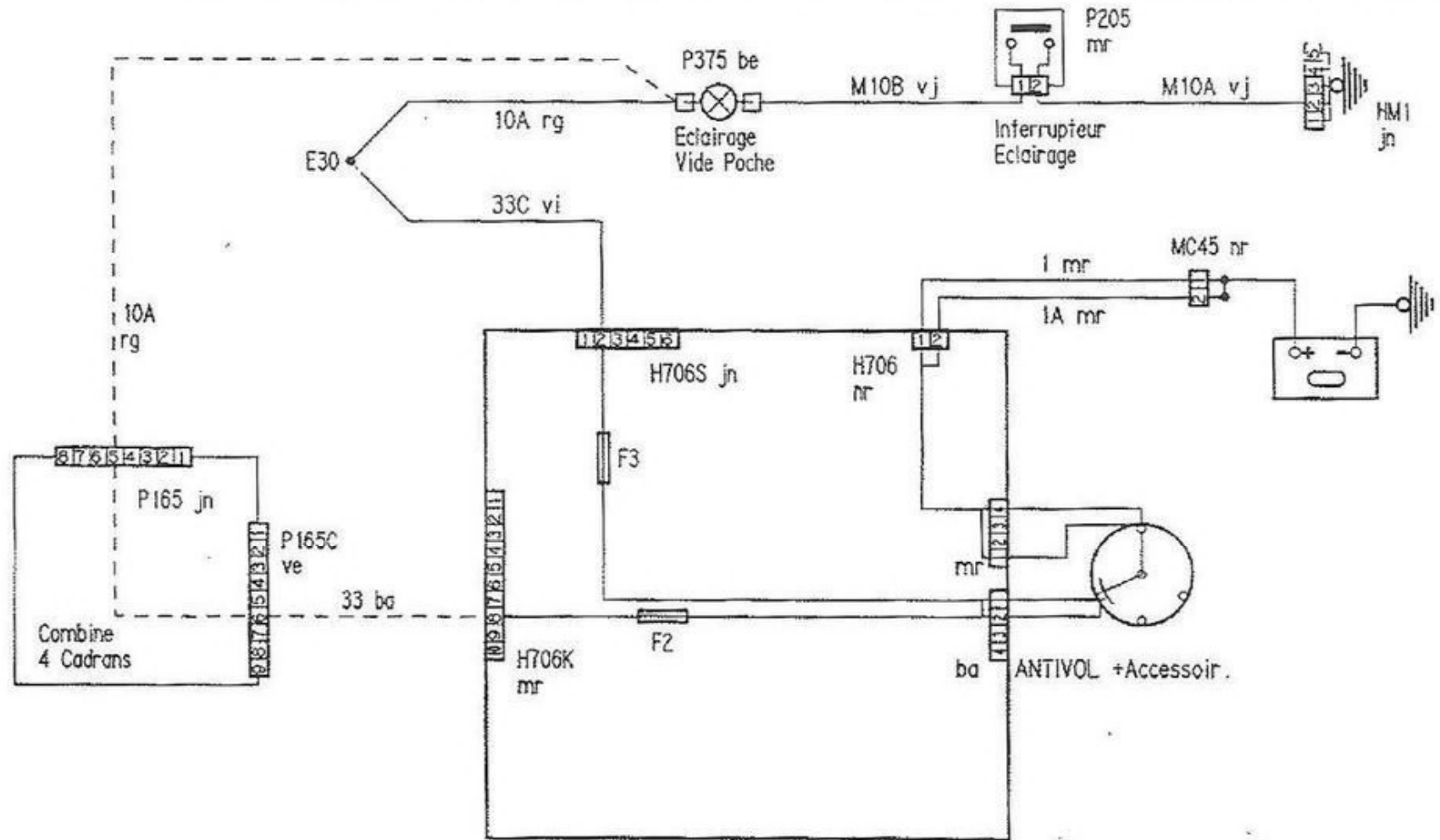

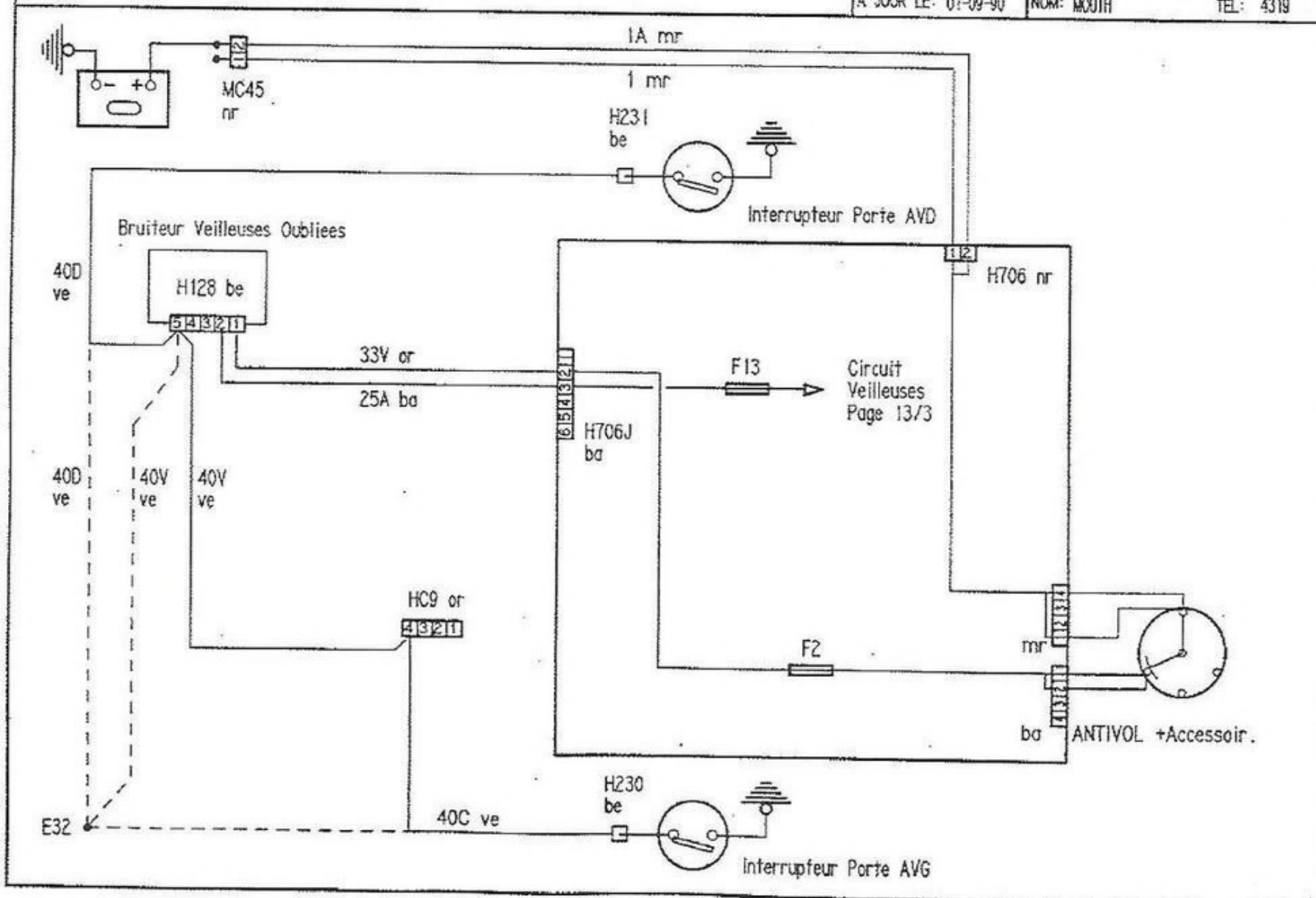

TYPES CONCERNES :
-205 avec Fonction L-V en + Permanent

LEVE VITRES ELECTRIQUES

26
2

A JOUR LE: 01-09-90

NOM: MONTH

TEL: 4319

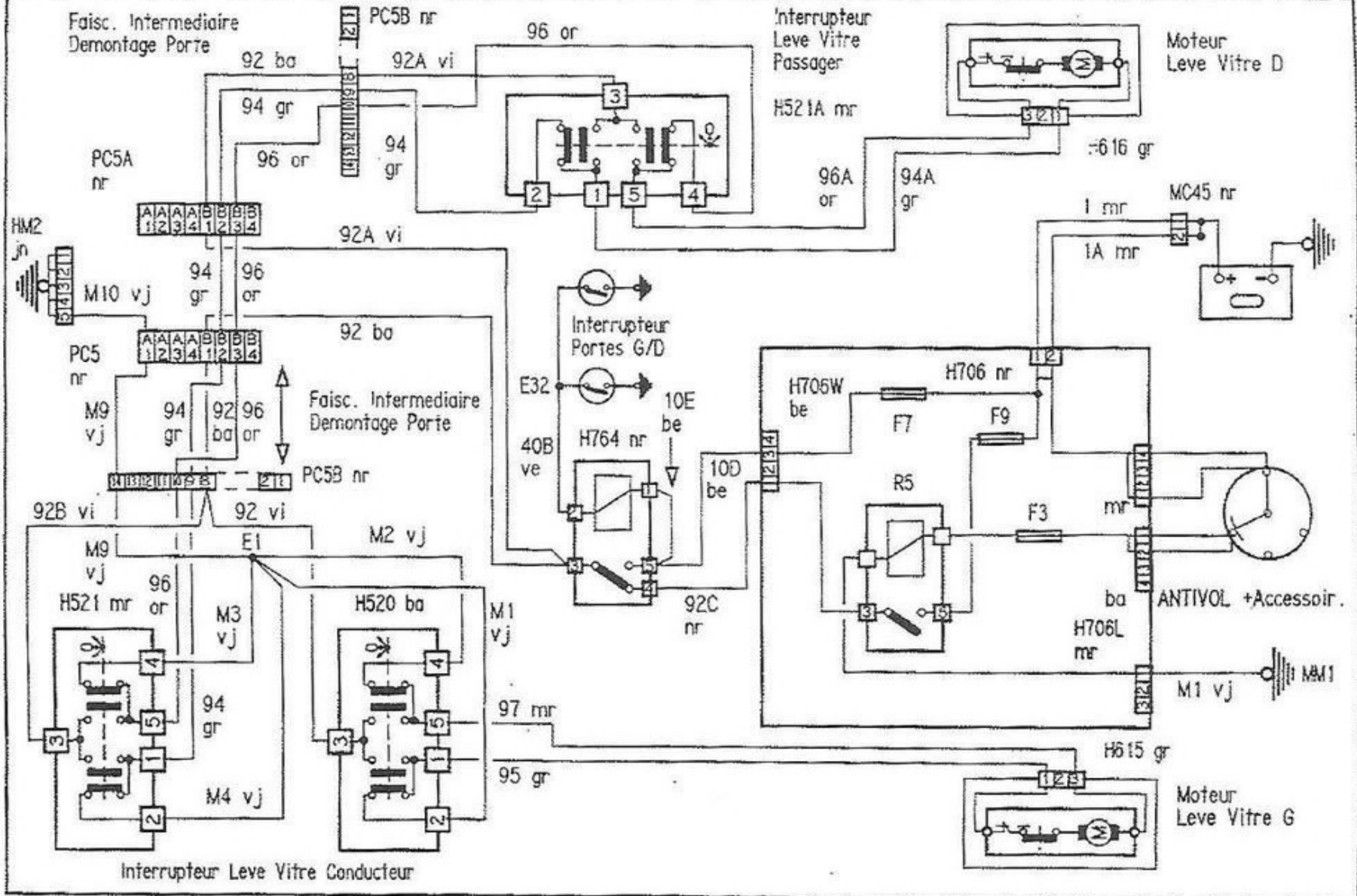

LEVE VITRES ELECTRIQUES

26
1

A JOUR LE: 01-09-90

NOM: MOUTH

TEL: 4319

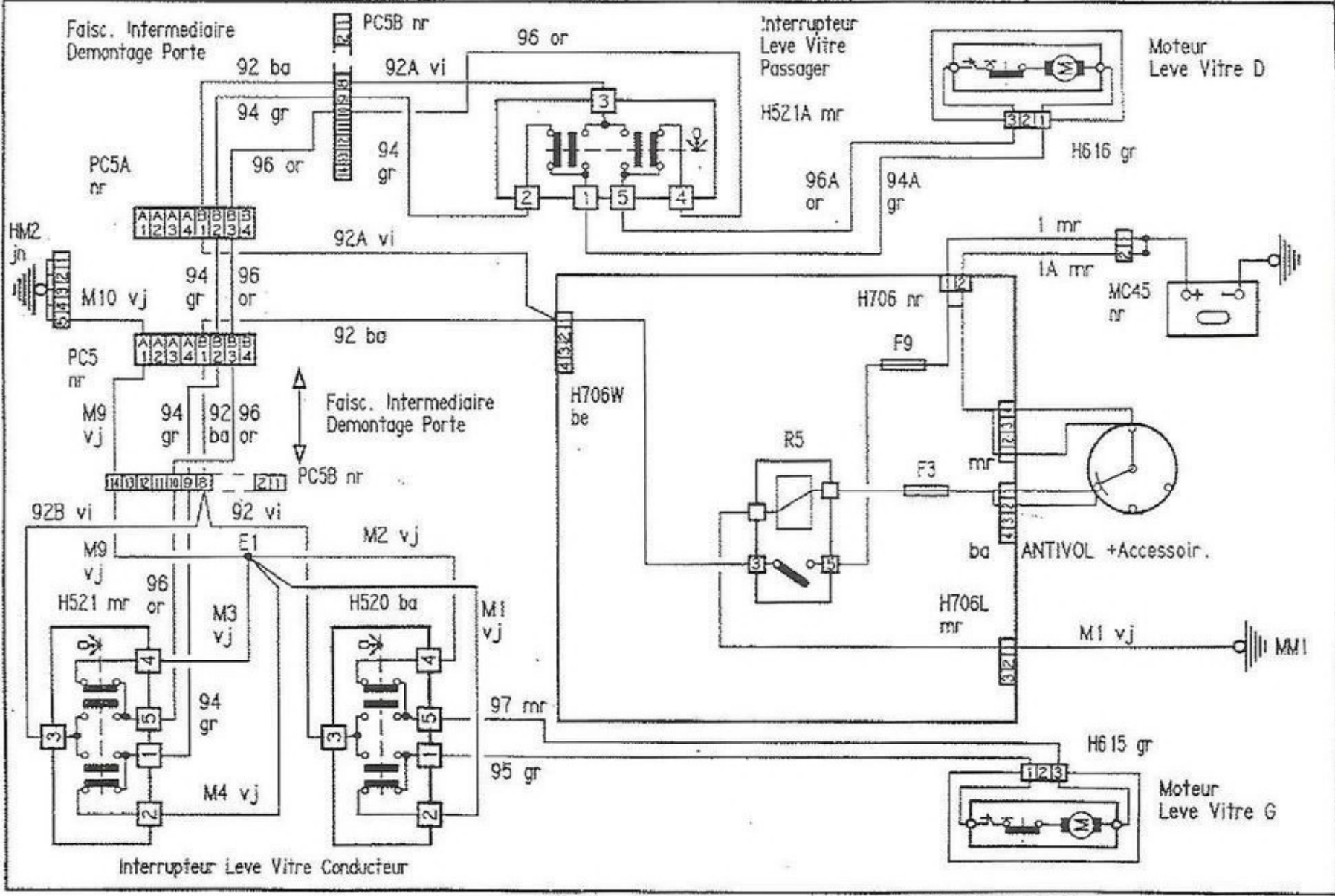

TYPES CONCERNES:
-205 3 PORTES

CONDAMNATION
CENTRALISEE

27
2

A JOUR LE: 01-09-90

NOM: MOUTON

TEL: 4319

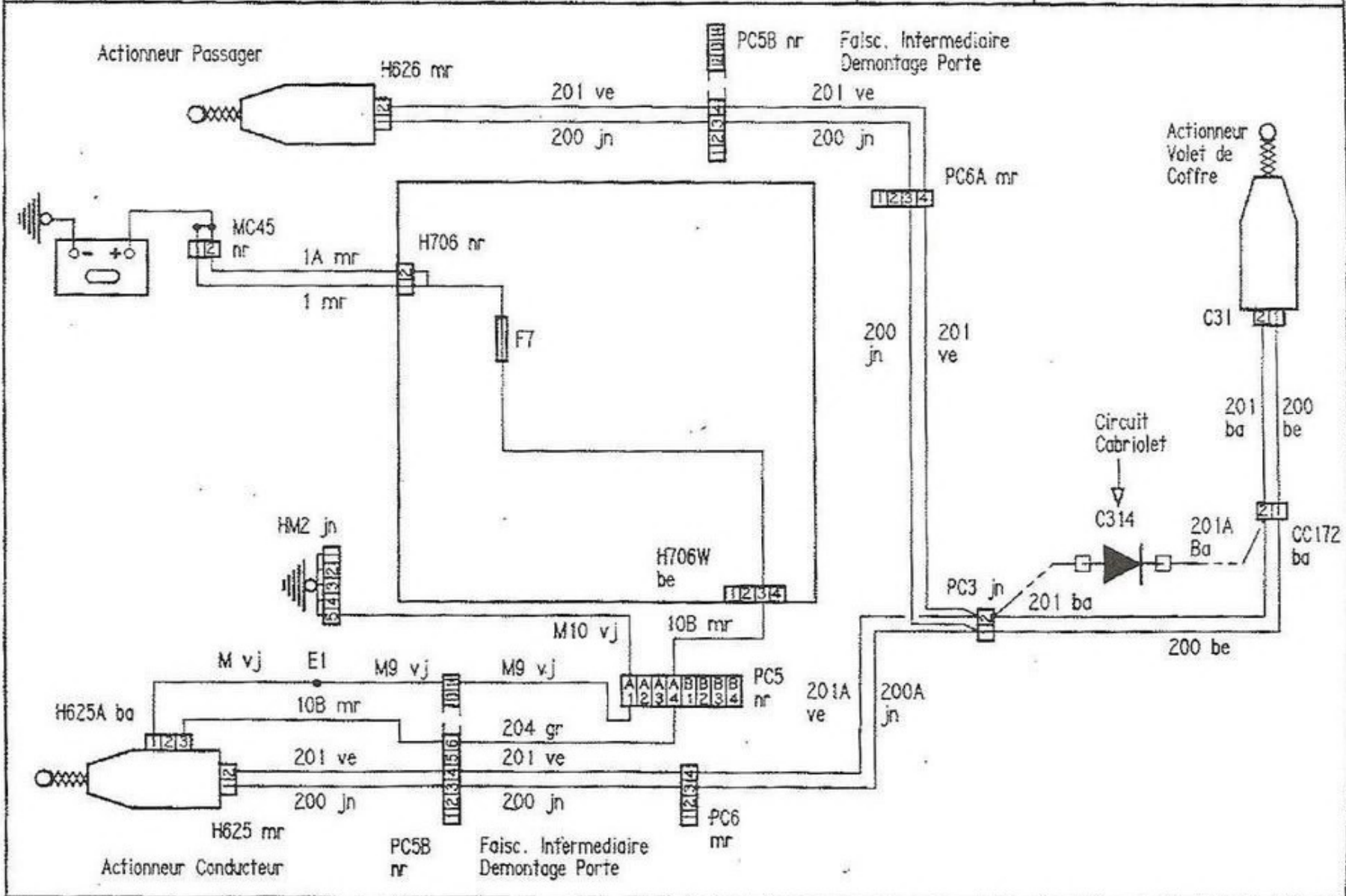

TYPES CONCERNES:
-205 5 PORTES

CONDAMNATION CENTRALISEE

27/1

A JOUR LE: 01-09-90

NOM: MOUTH

TEL: 4319

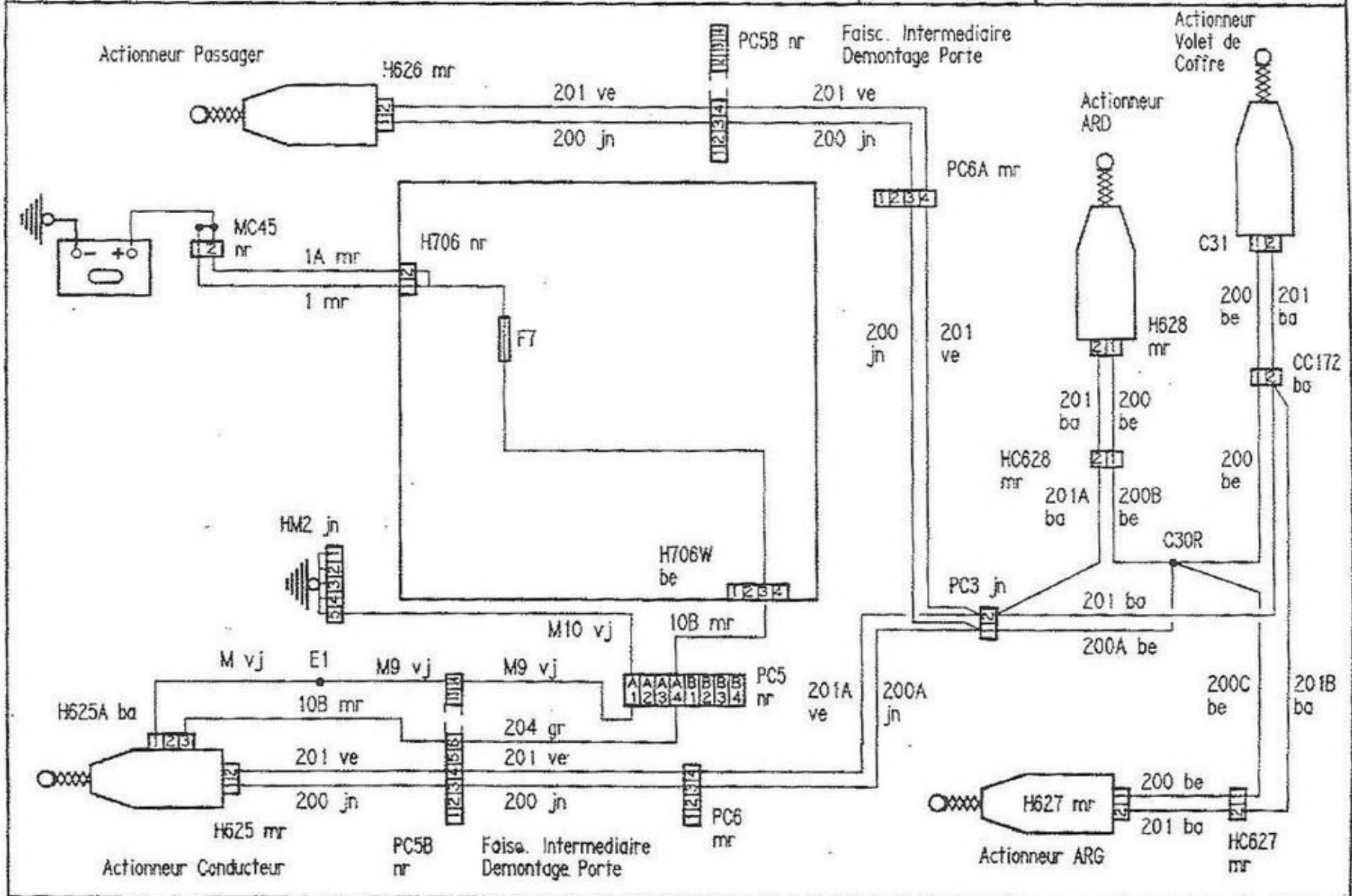

TYPES CONCERNES:
-205 3 PORTES

CONDAMNATION
CENTRALISEE PLIP

27
3

A JOUR LE: 01-09-90

NOM: MCUTH

TEL: 4319

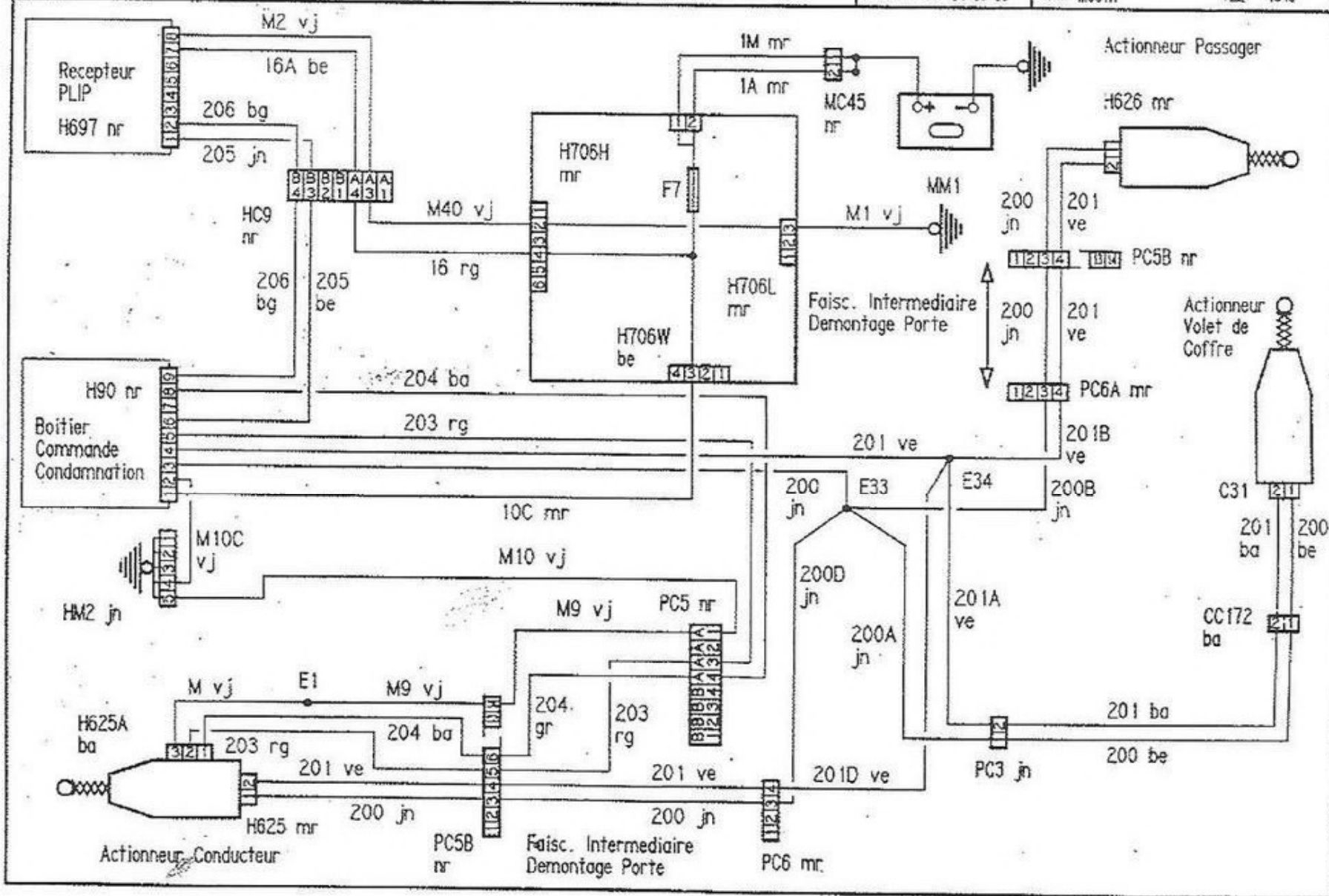

EN POINTILLES : XU*J*
XU5M

FEUX DE REcul T.T. B V M

29

A JOUR LE: 01-09-90

NOM: MOUTH

TEL: 4319

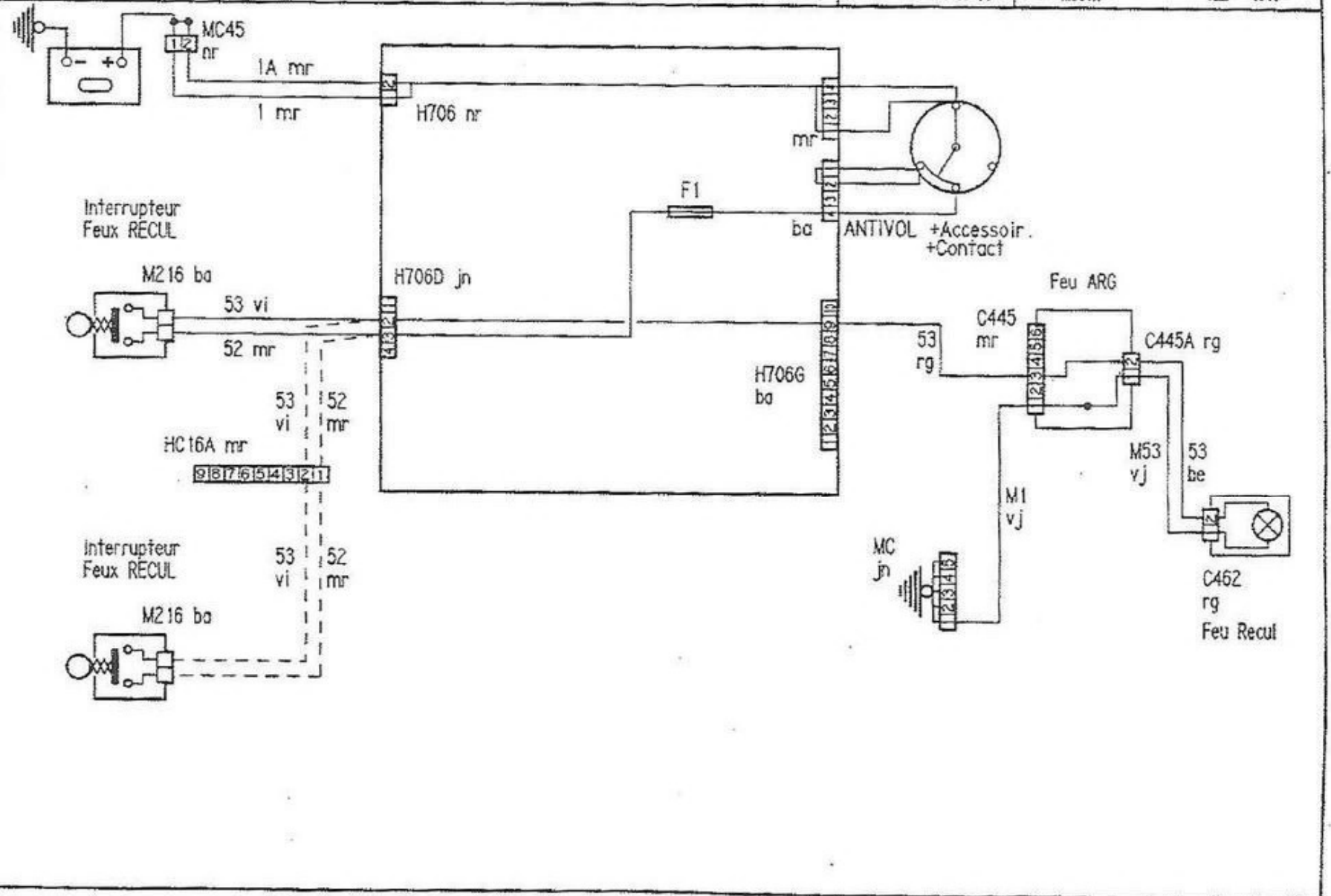

TYPE CONCERNE :
-205 BVA
XU9J JAZ

INTERDICT. DEMARRAGE
ECLAIR. CONS. sauf GF

29
6

A JOUR LE: 01-09-90

NOM: MOUTH

TEL: 4319

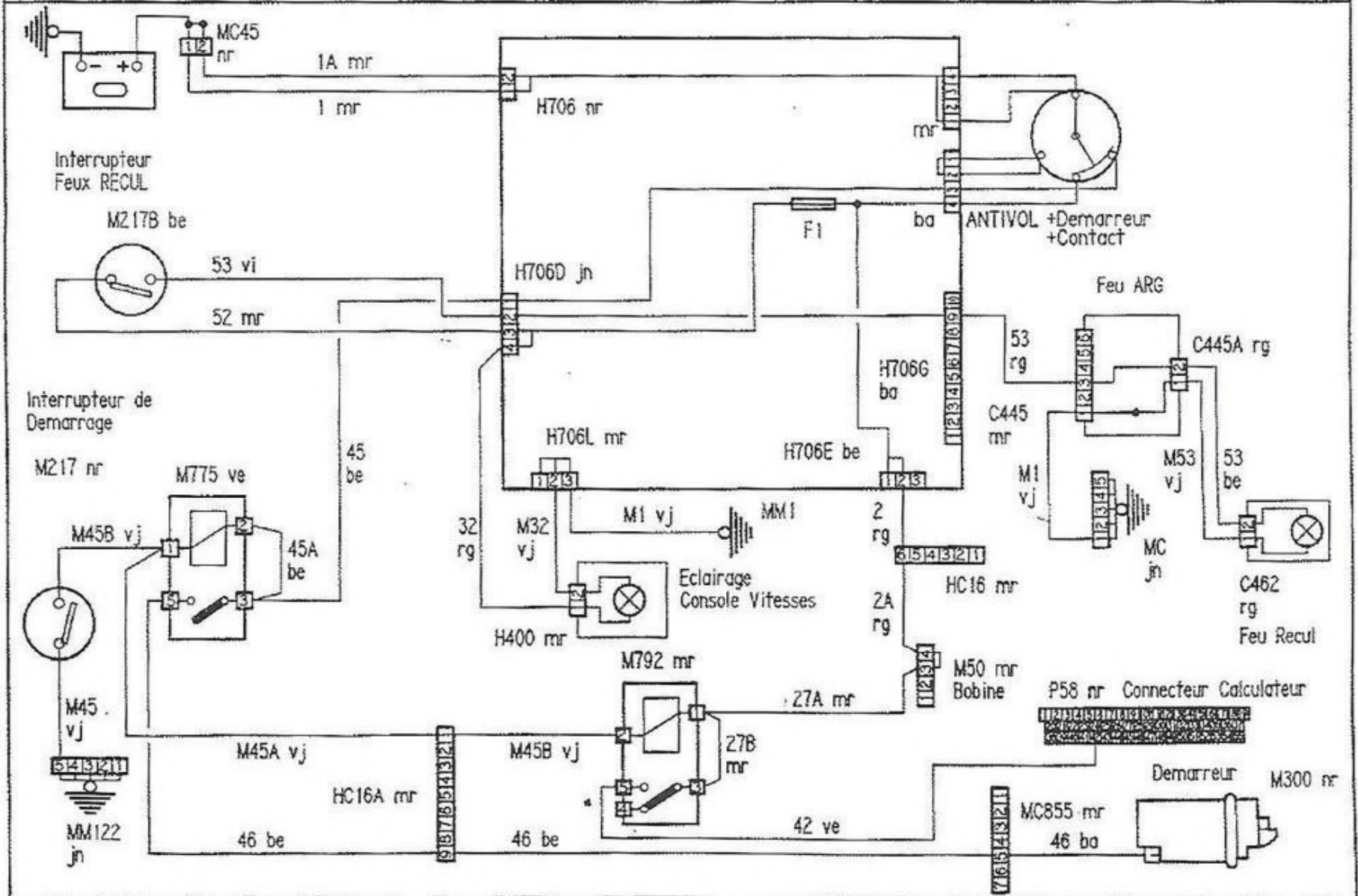

TYPE CONCERNE :
-205 BVA
XU5M

INTERDICT. DEMARRAGE
ECLAIR. CONS. sauf GF

29
5

A JOUR LE: 01-09-90

NOM: MOUTH

TEL: 4319

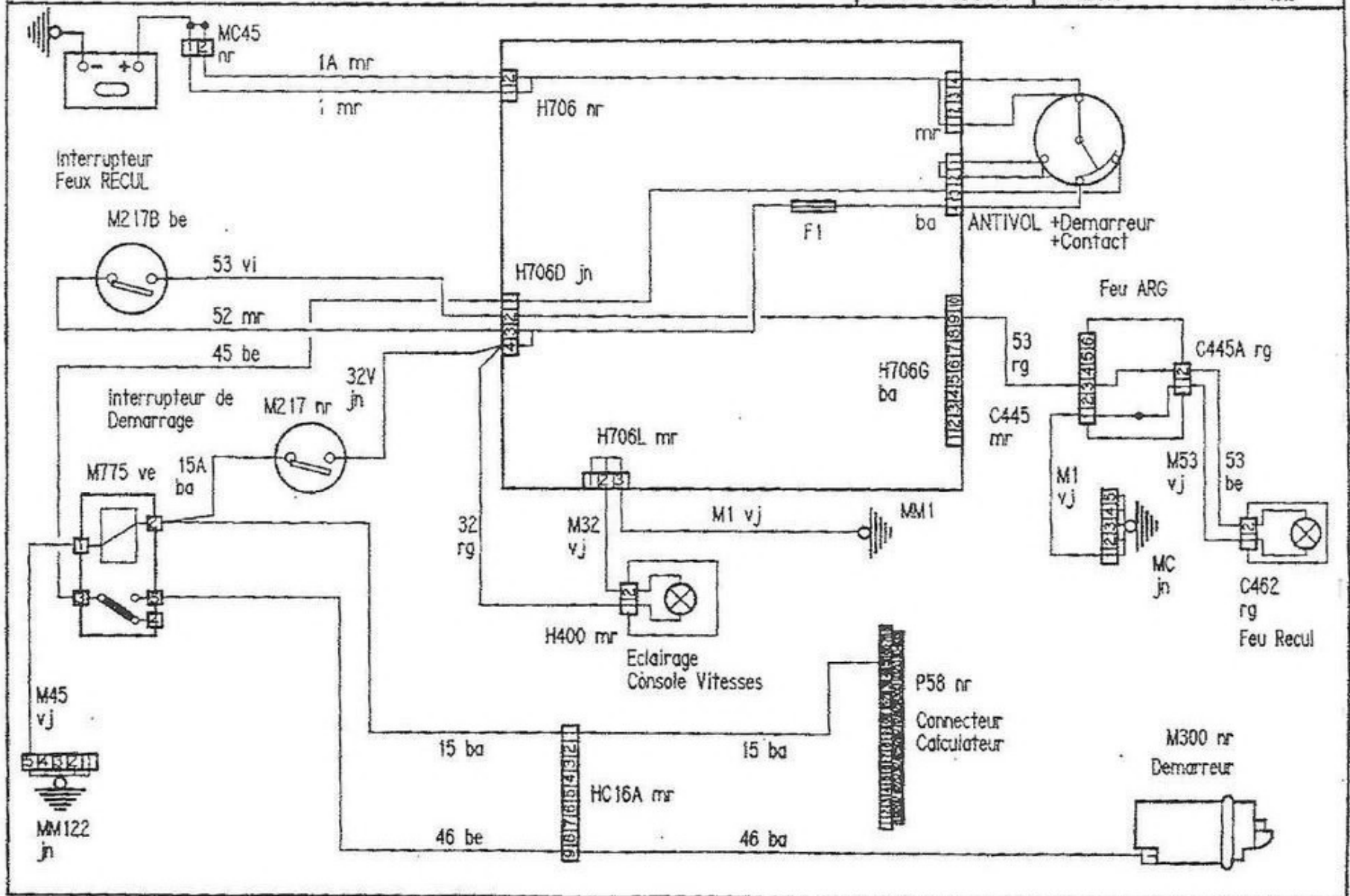

TYPE CONCERNE :
-205 BVA GRAND FROID
XU5M

INTERDICT. DEMARRAGE
ECLAIR. CONS. GF

29
4

A JOUR LE: 01-09-90

NOM: MOUTH

TEL: 4319

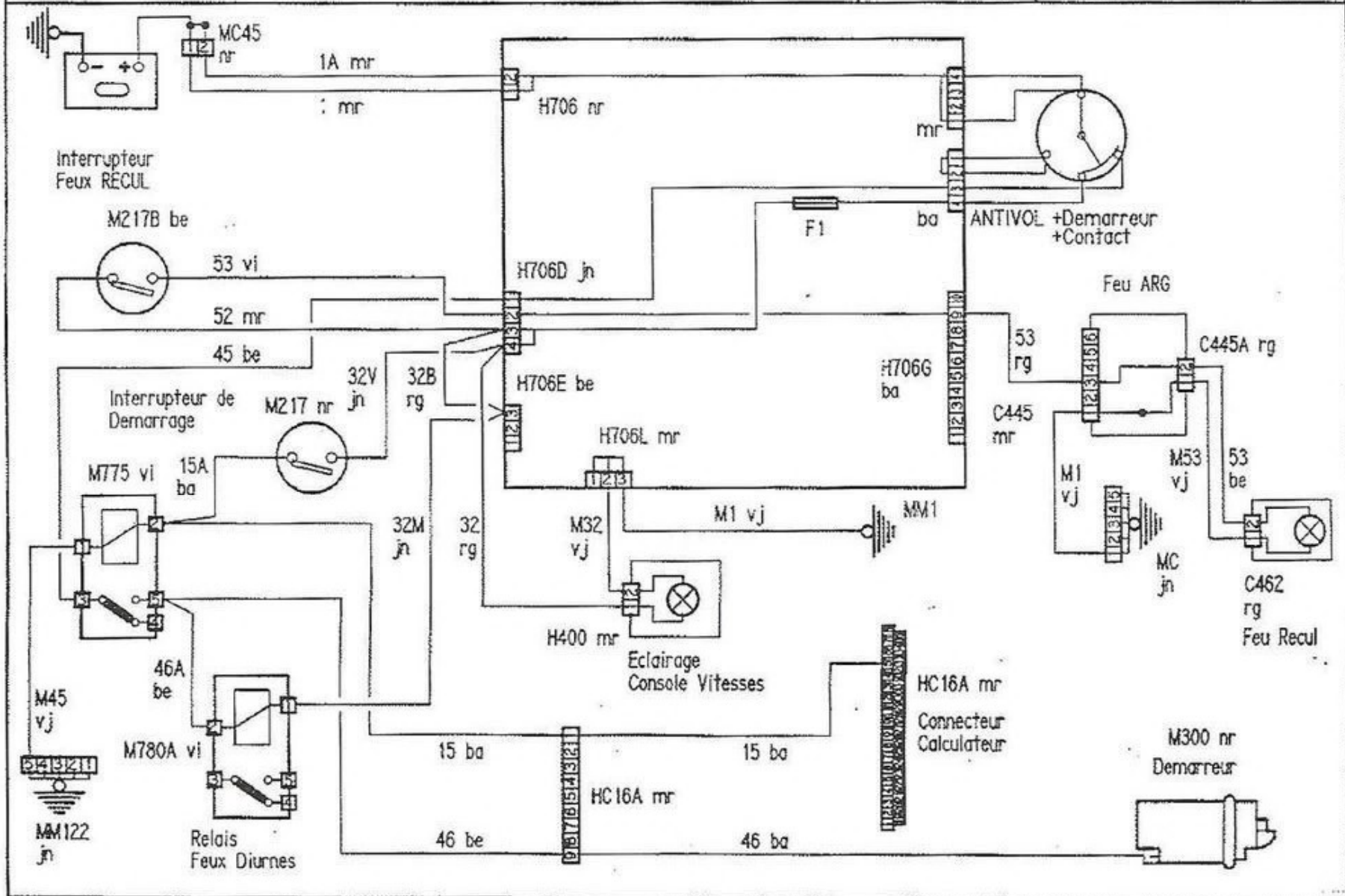

EN POINTILLES : XU*J1

TYPE CONCERNE :
-205 BVA GRAND FROID
XU51C
XU*J1

INTERDICT. DEMARRAGE
ECLAIR. CONS. GF

29
3

A JOUR LE: 01-09-90

NCM: MOJTH

TEL: 4319

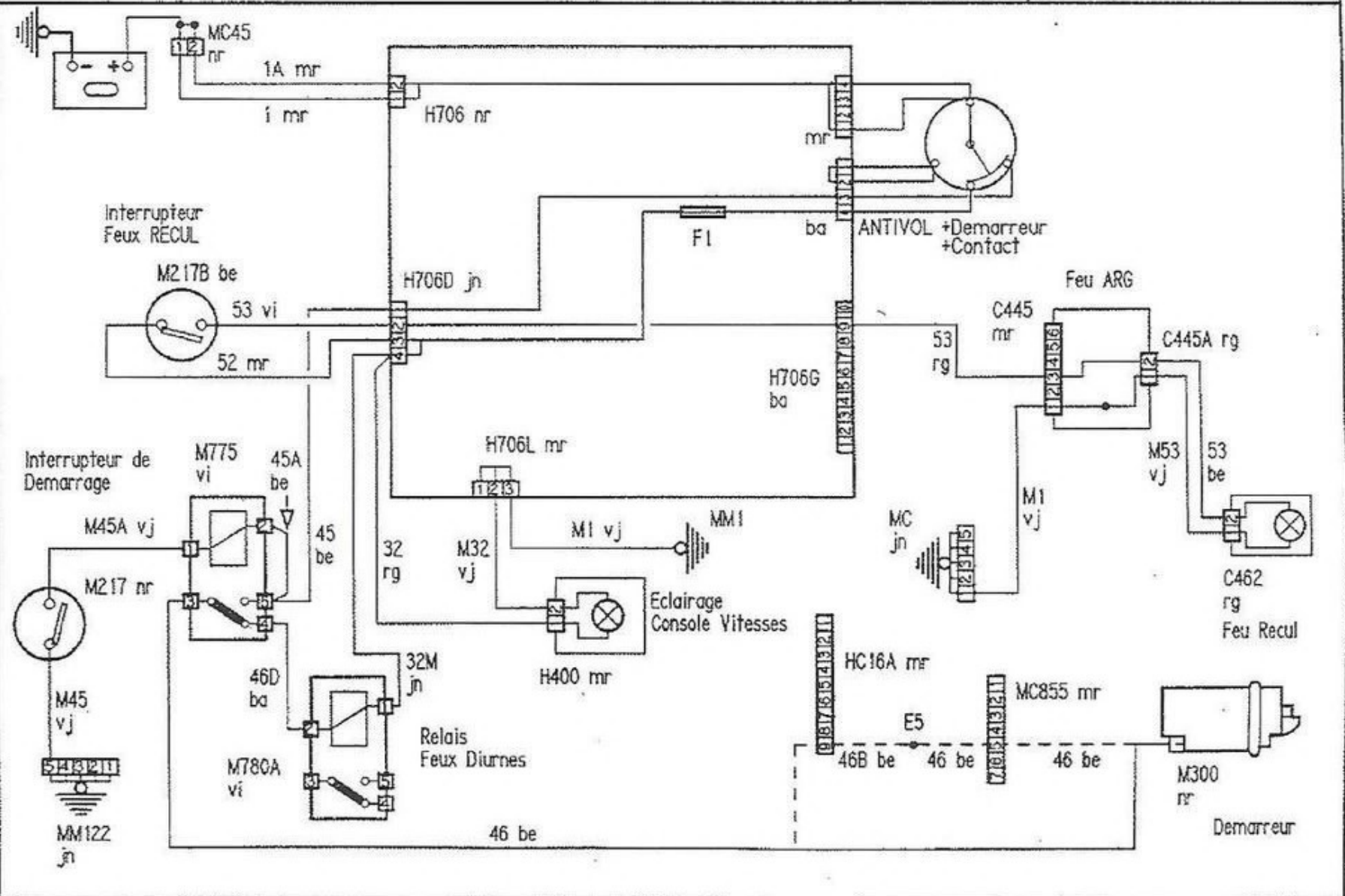

EN POINTILLES : XU*J1

TYPE CONCERNE :
-205 BVA
XU51C
XU*J1

INTERDICT. DEMARRAGE
ECLAIR. CONS. sauf GF

29
2

A JOUR LE: 01-09-90

NOM: MOJTH

TEL: 4319

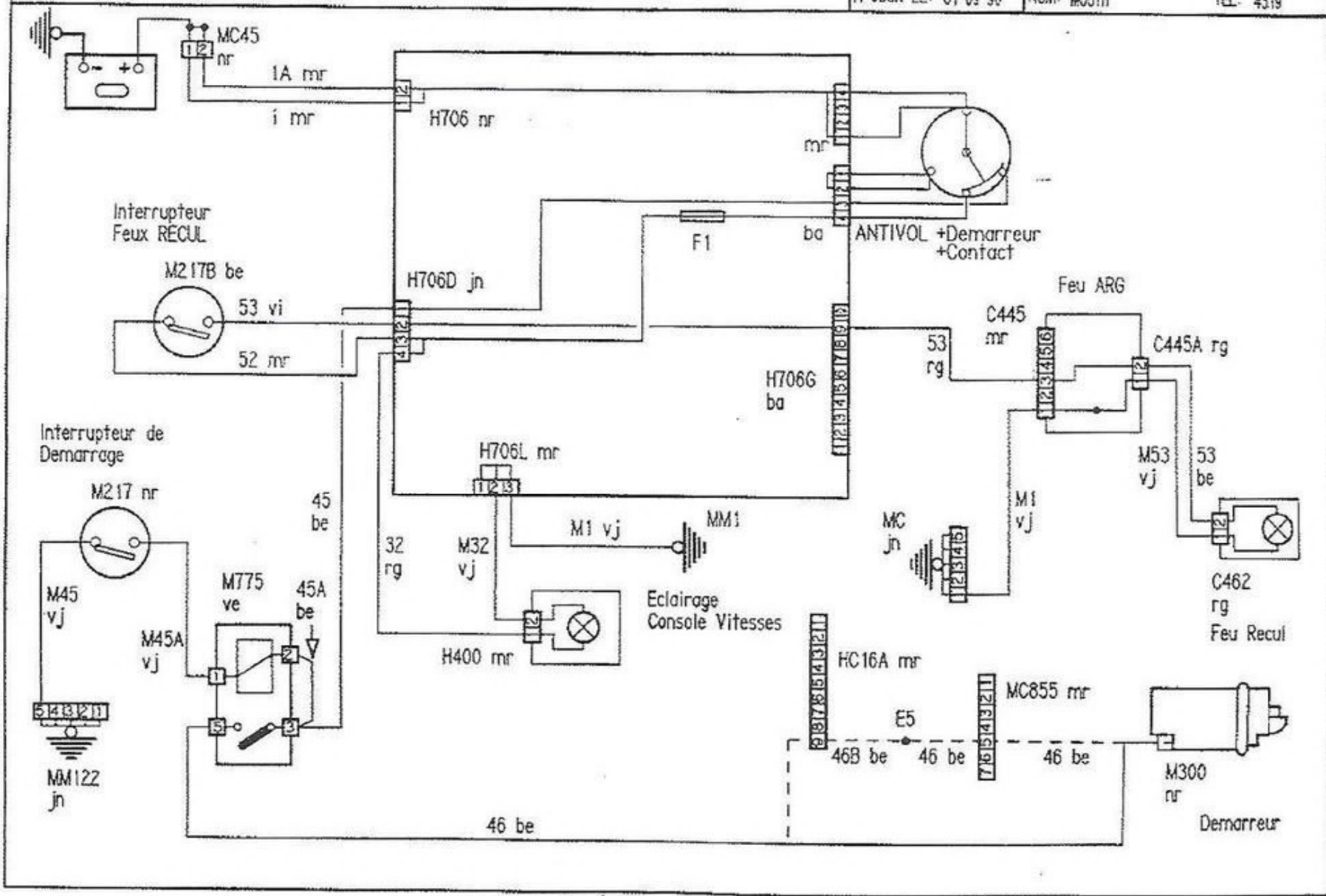

TYPES CONCERNES :
- 205 Direction Droite

FEU ARRIERE BROUILL

30/2

A JOUR LE: 01-09-90

NOM: MCUTH

TEL: 4319

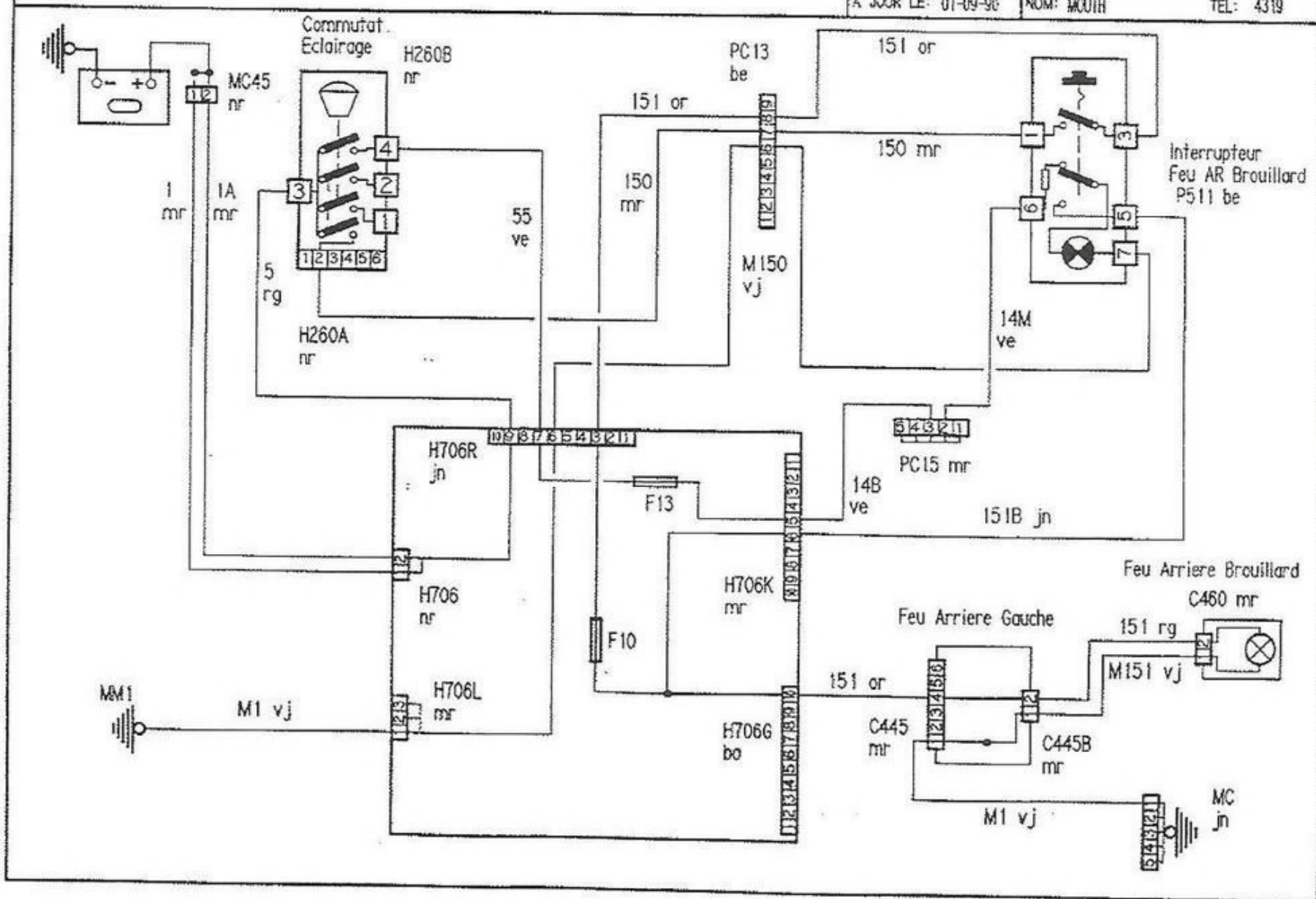

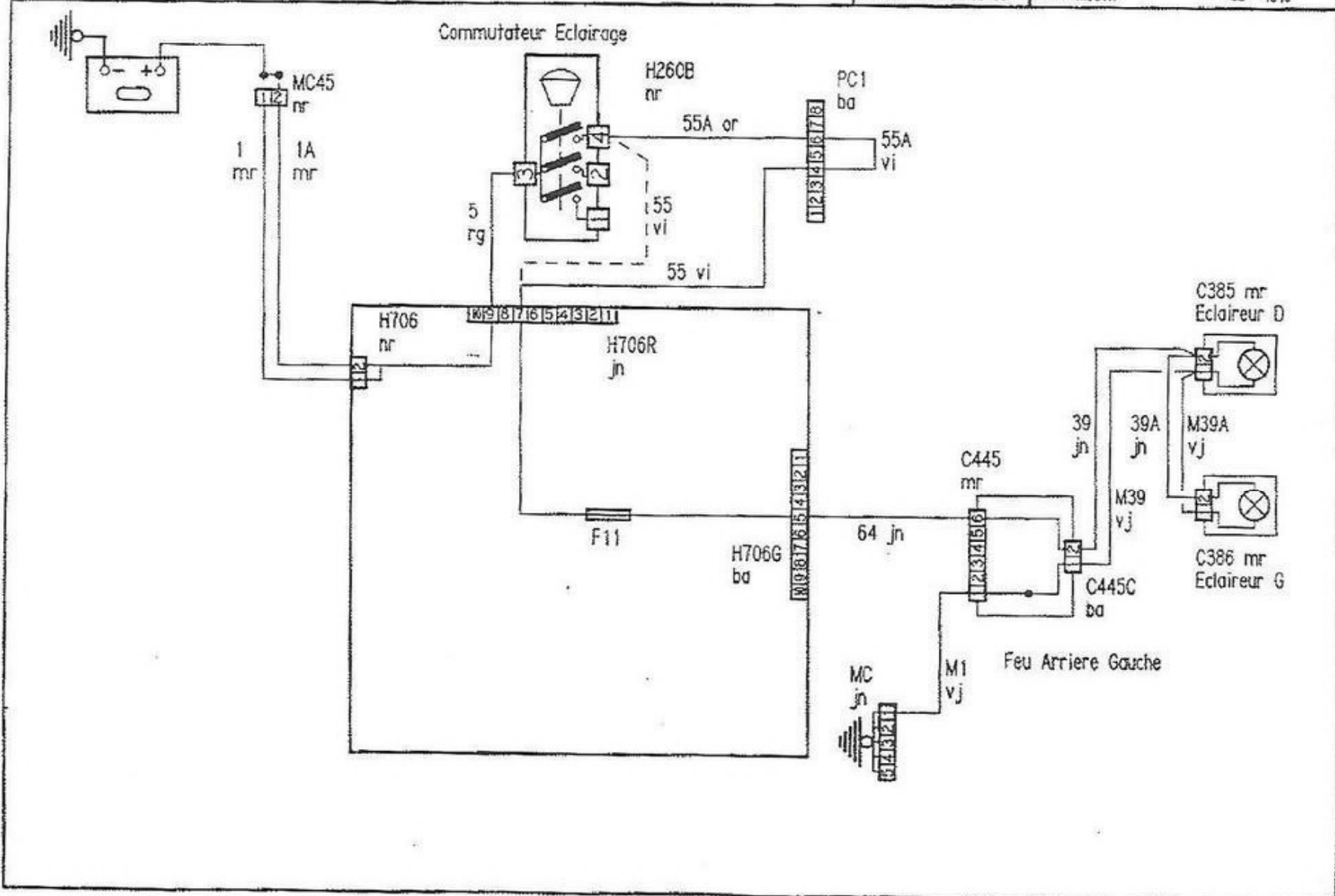

PC13 be: Specific Direction Droite

TYPES CONCERNES:
-205 AVEC COMBINE
4 CADRANS

JAUGE CARBURANT

32
2

A JOUR LE: 01-07-90

NOM: MOUTH

TEL: 4319

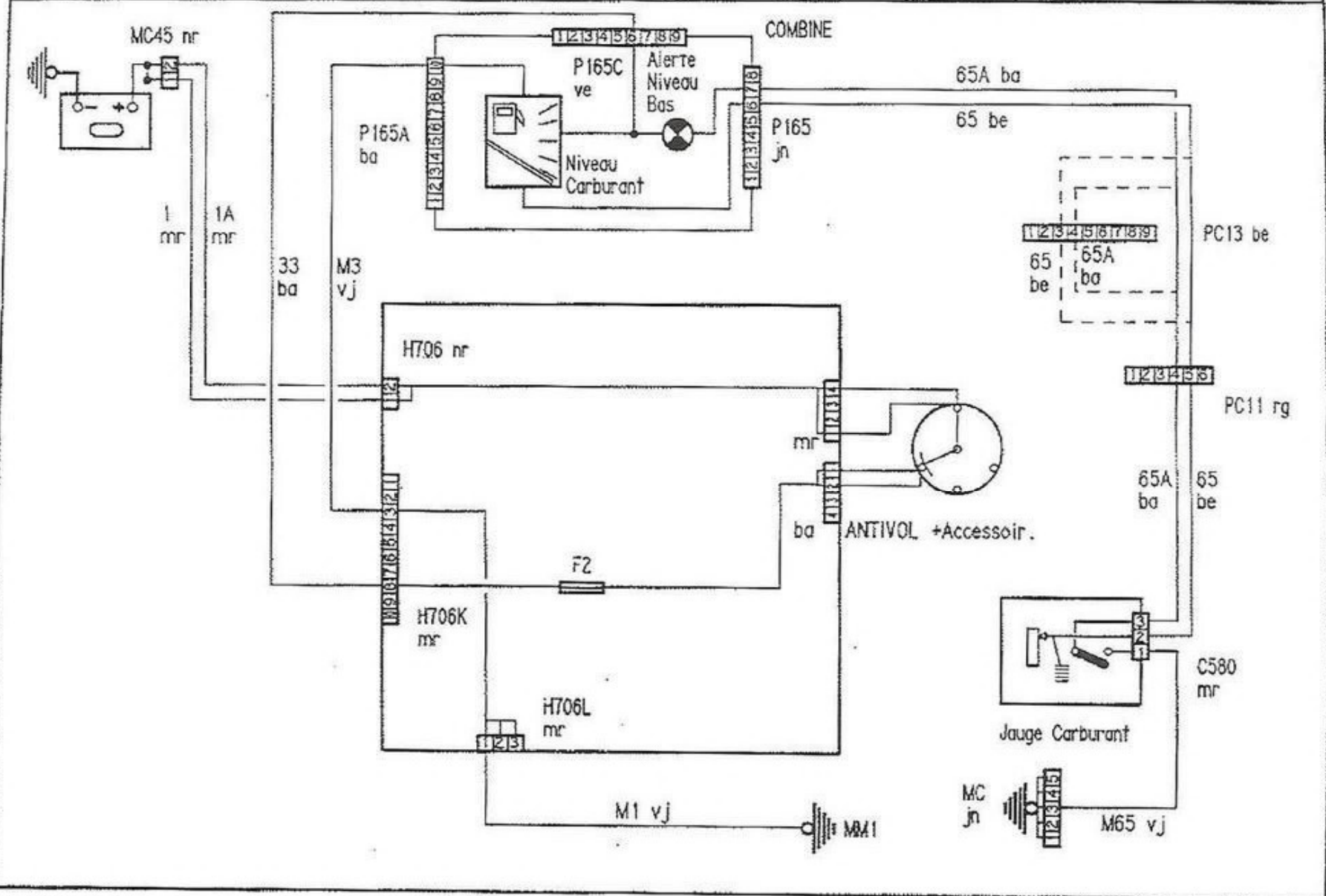

PC13 be: Specific Direction Droite

TYPES CONCERNES:
-205 AVEC COMBINE
3 CADRANS

JAUGE CARBURANT

32/1

A JOUR LE: 01-07-90

NOM: MOUTH

TEL: 4319

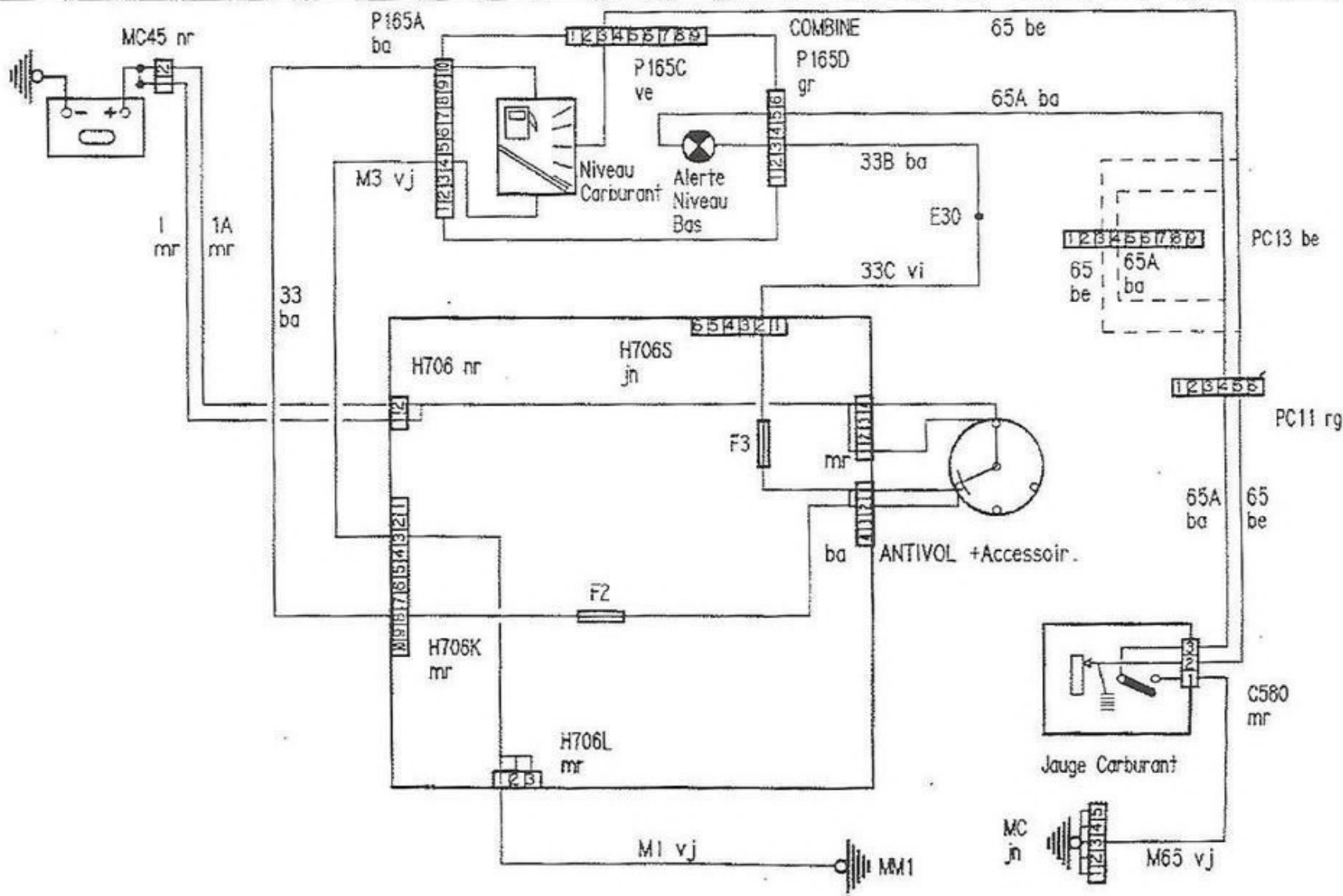

LUNETTE CHAUFFANTE RETRO-CHAUFFANT

33
1

A JOUR LE: 01-09-90 NOM: MOUTH TEL: 4319

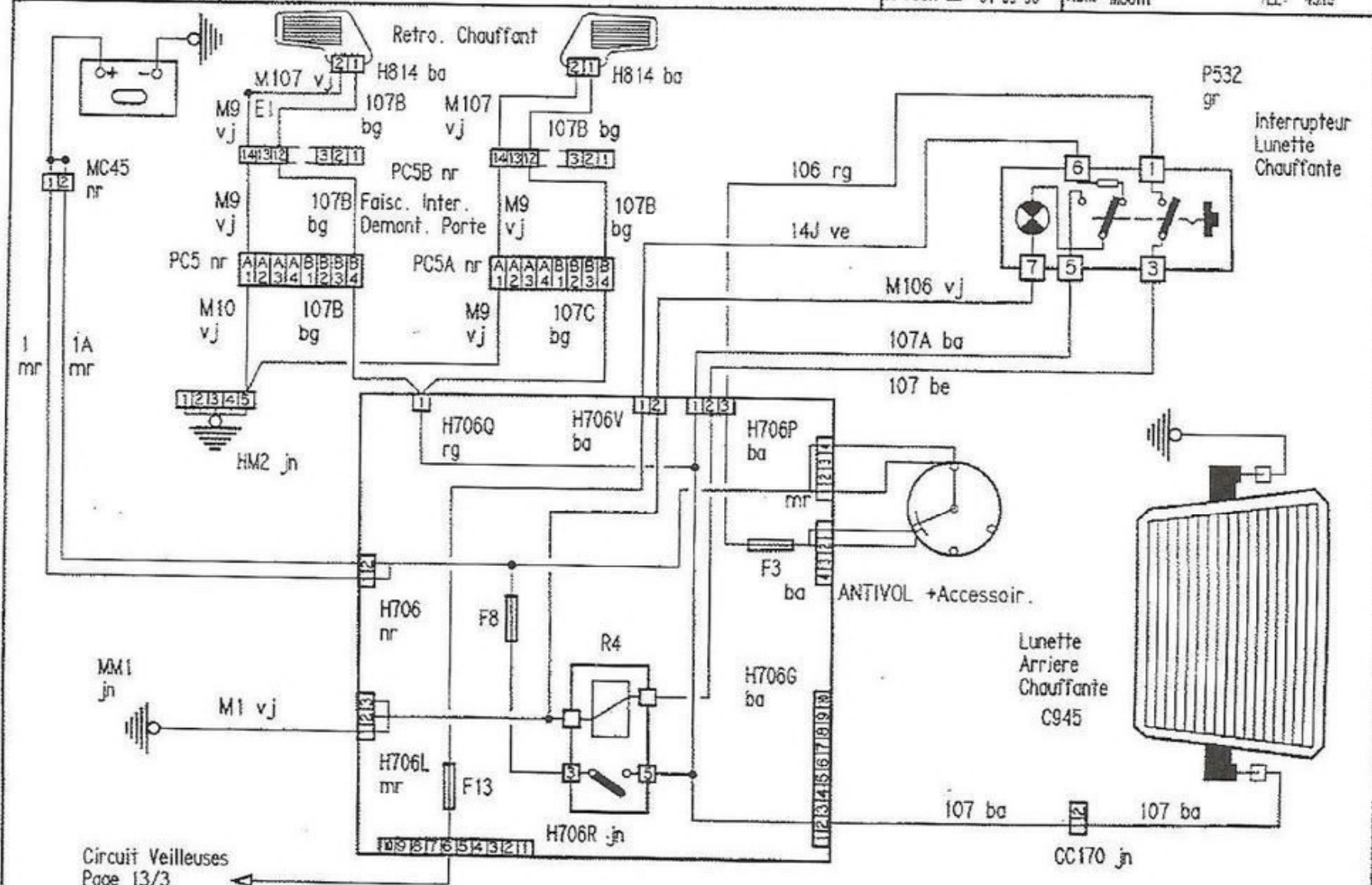

Circuit Veilleuses
Page 13/3

ESSUIE VITRE ARRIERE

34

A JOUR LE: 01-03-90

NOM: MOUTH

TEL: 4319

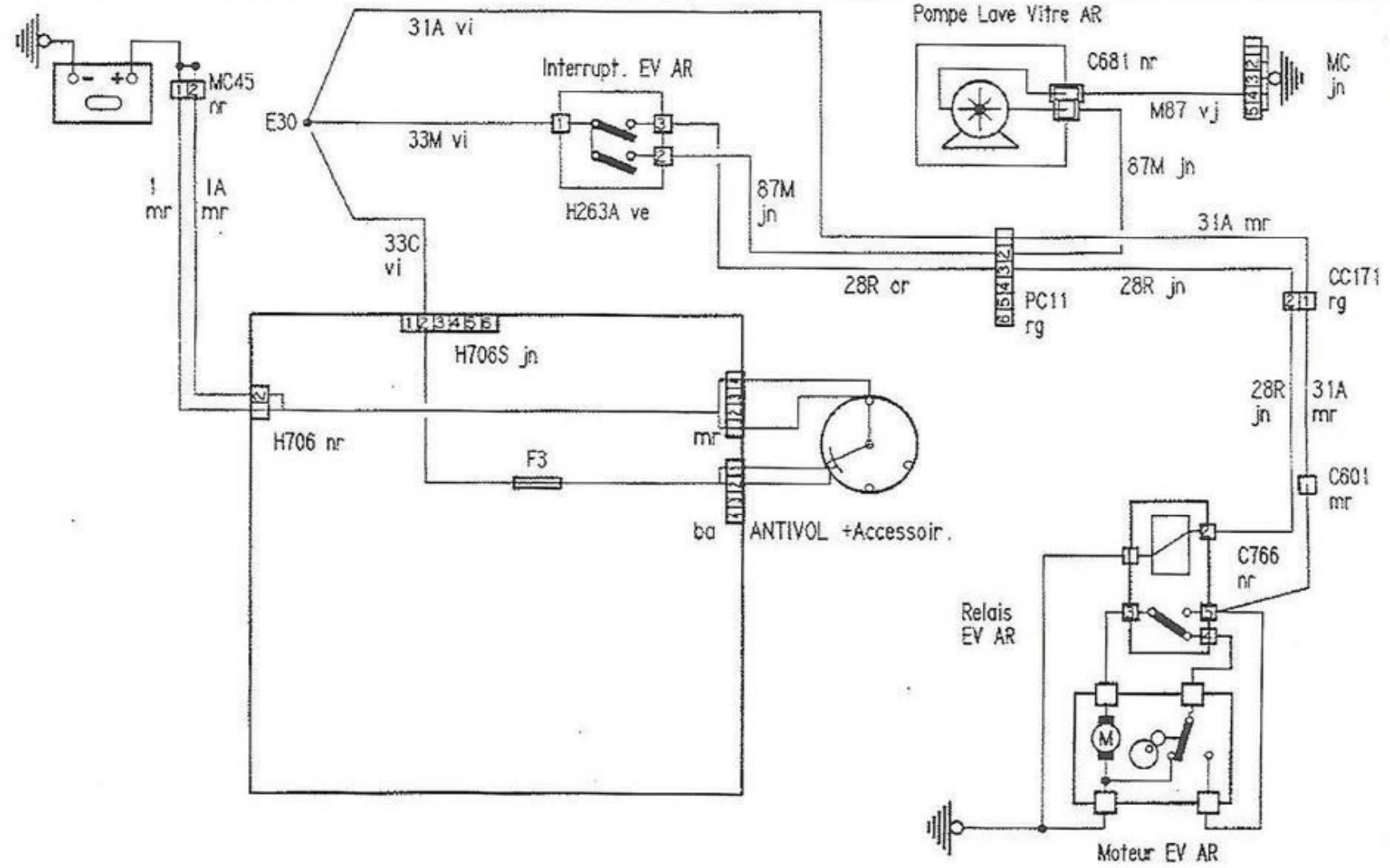

TYPES CONCERNES:
-205ESS
-205DSL
-205GT1

ALIMENTATION ATTACHE REMORQUE

35
1

A JOUR LE: 01-07-90

NOM: MOUTH

TEL: 4319

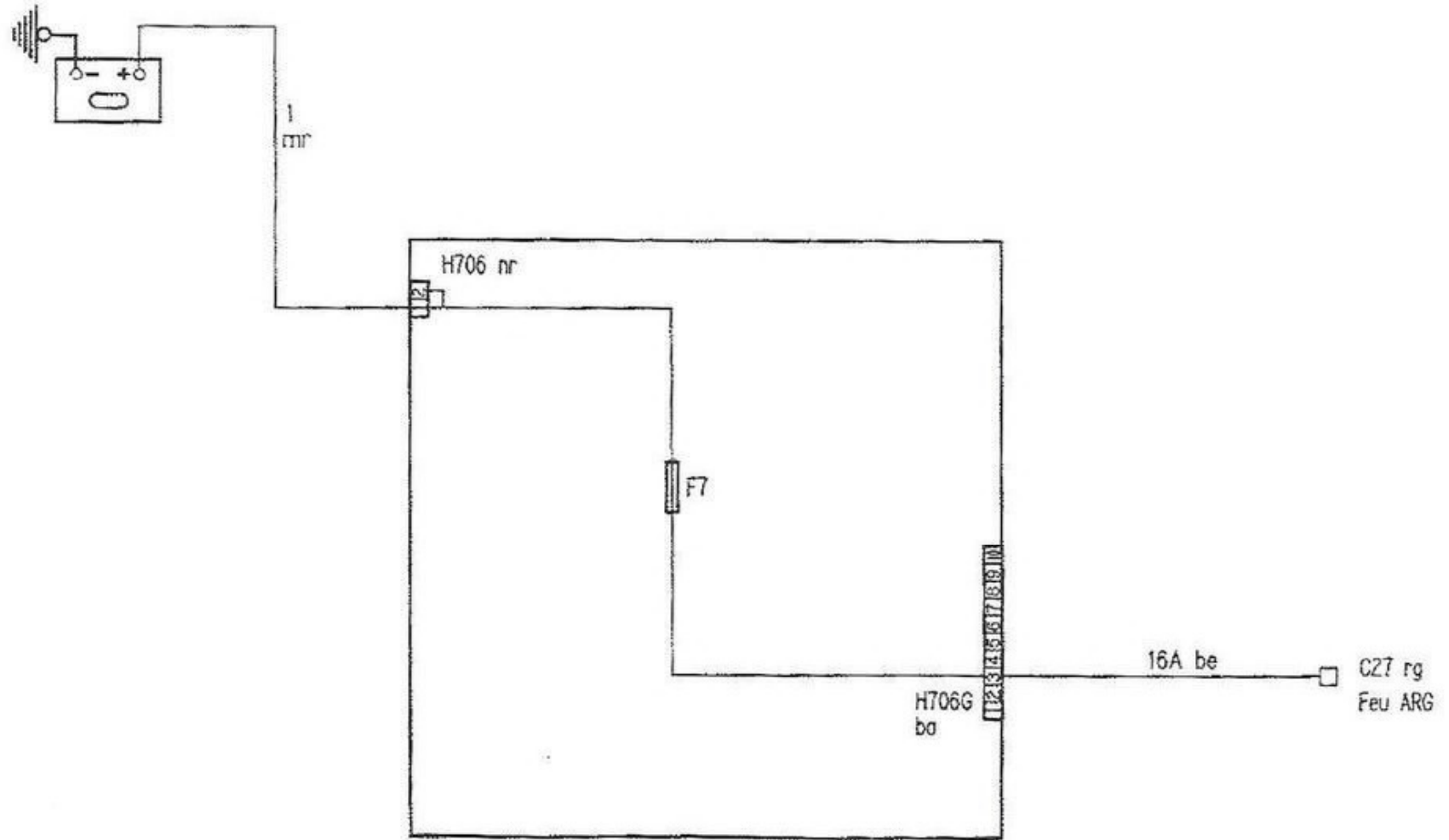

ECLAIREUR COFFRE

36
1

A JOUR LE: 01-07-90

NOM: MOUTH

TEL: 4319

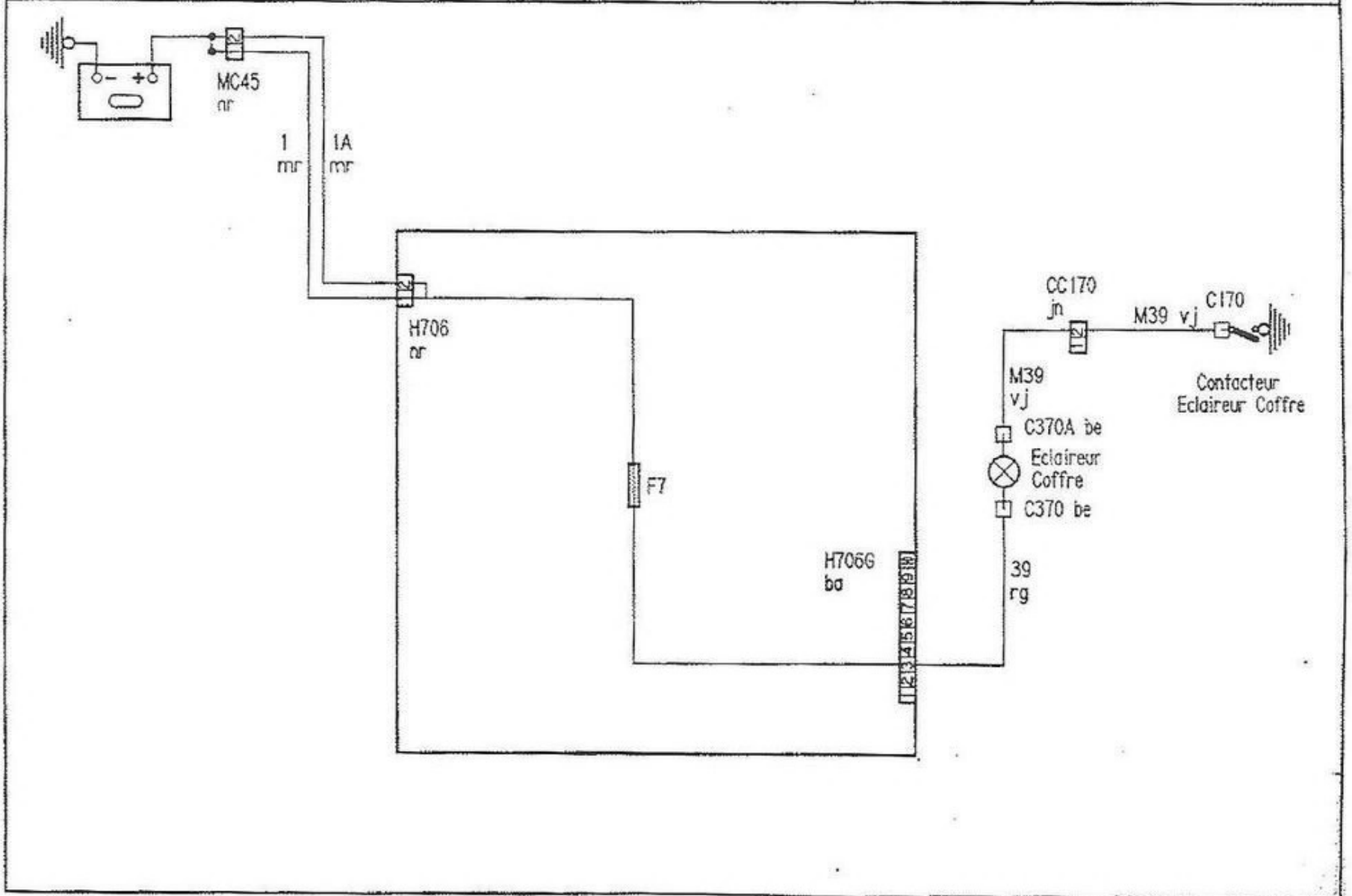

LAVE PROJECTEURS

37
1

A JOUR LE: 01-07-90

NOM: MOUTH

TEL: 4319

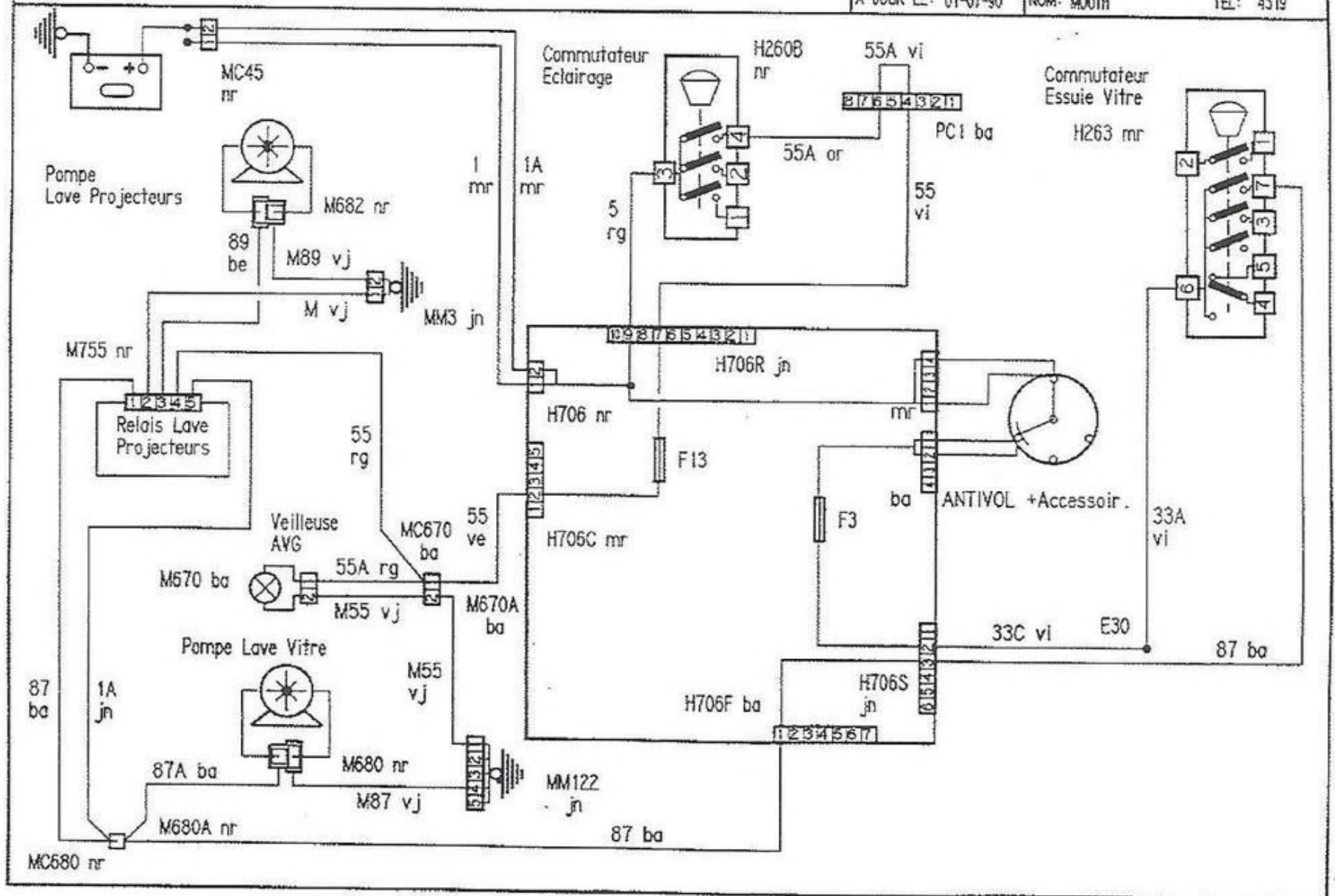



SIEGES CHAUFFANTS POMPE ADDITIONNELLE

38
1

A JOUR LE: 01-07-90

NOM: MOUTH

TEL: 4319

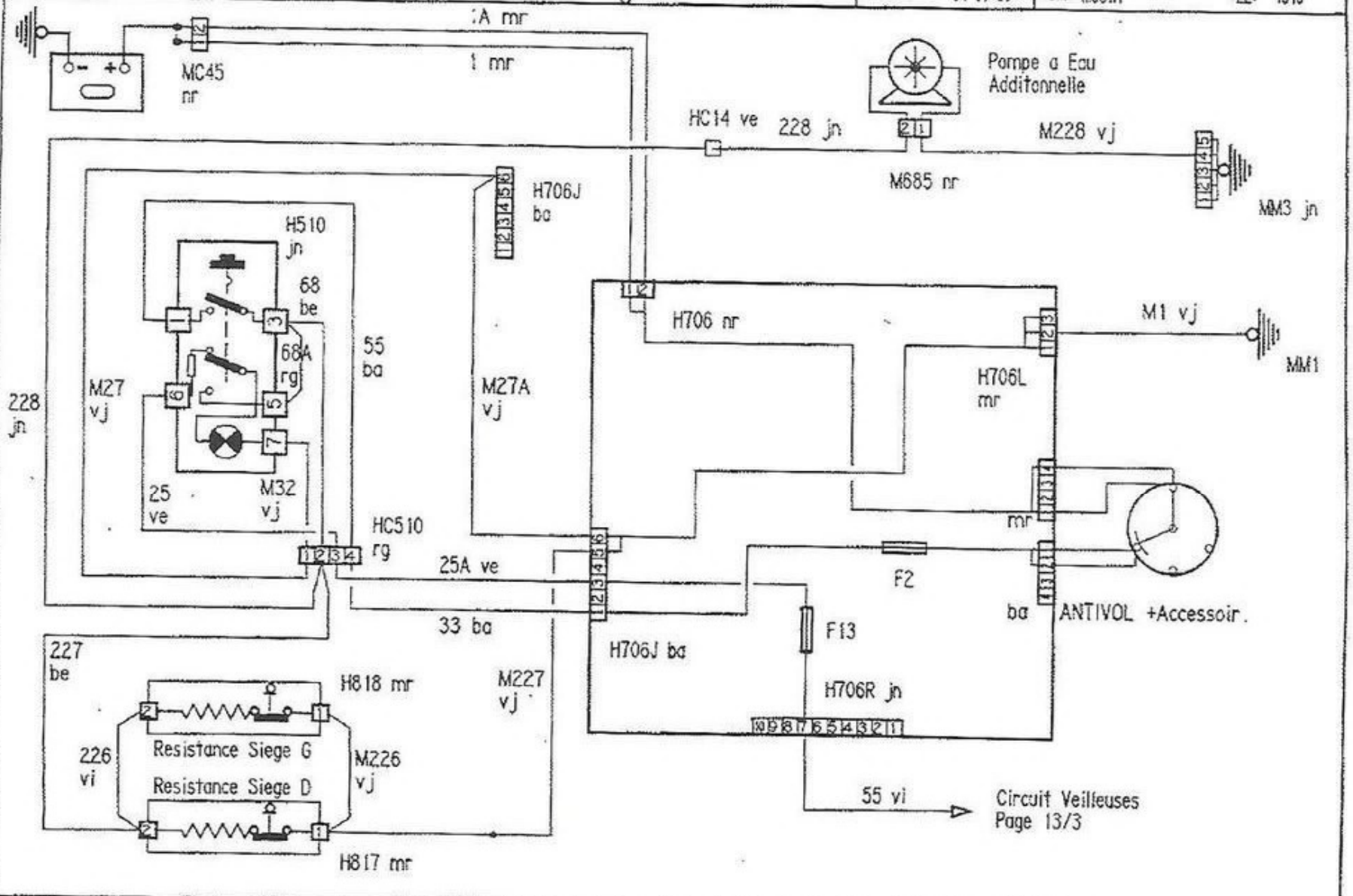

TYPES CONCERNES:
-205 ESSENCE
sauf BVA

FEUX DIURNES

39

A JOUR LE: 01-09-90

NOM: MOUTH

TEL: 4319

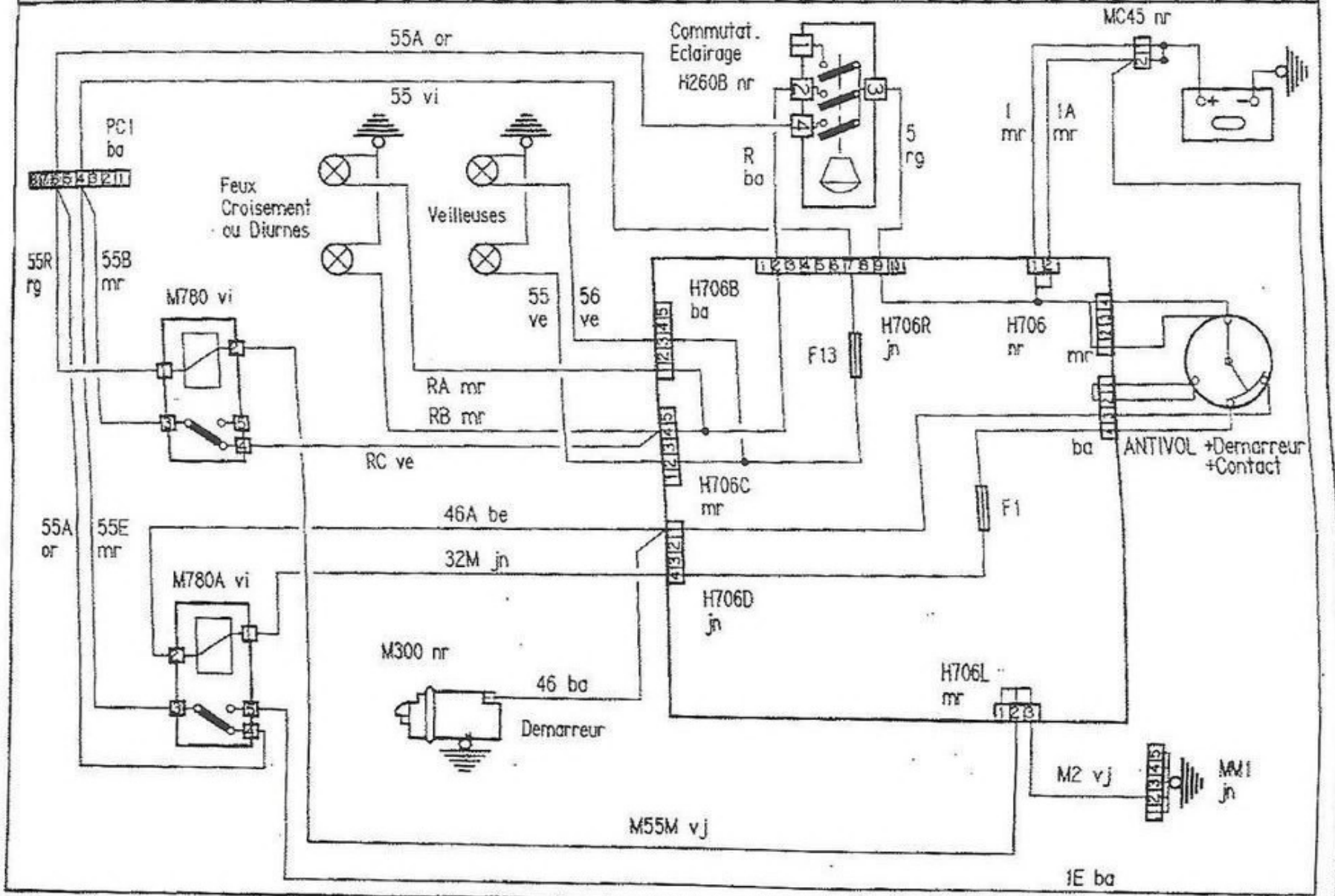

TYPES CONCERNES:
-205 XU5M BVA

FEUX DIURNES

39
4

A JOUR LE: 01-09-90

NOM: MOUTH

TEL: 4319

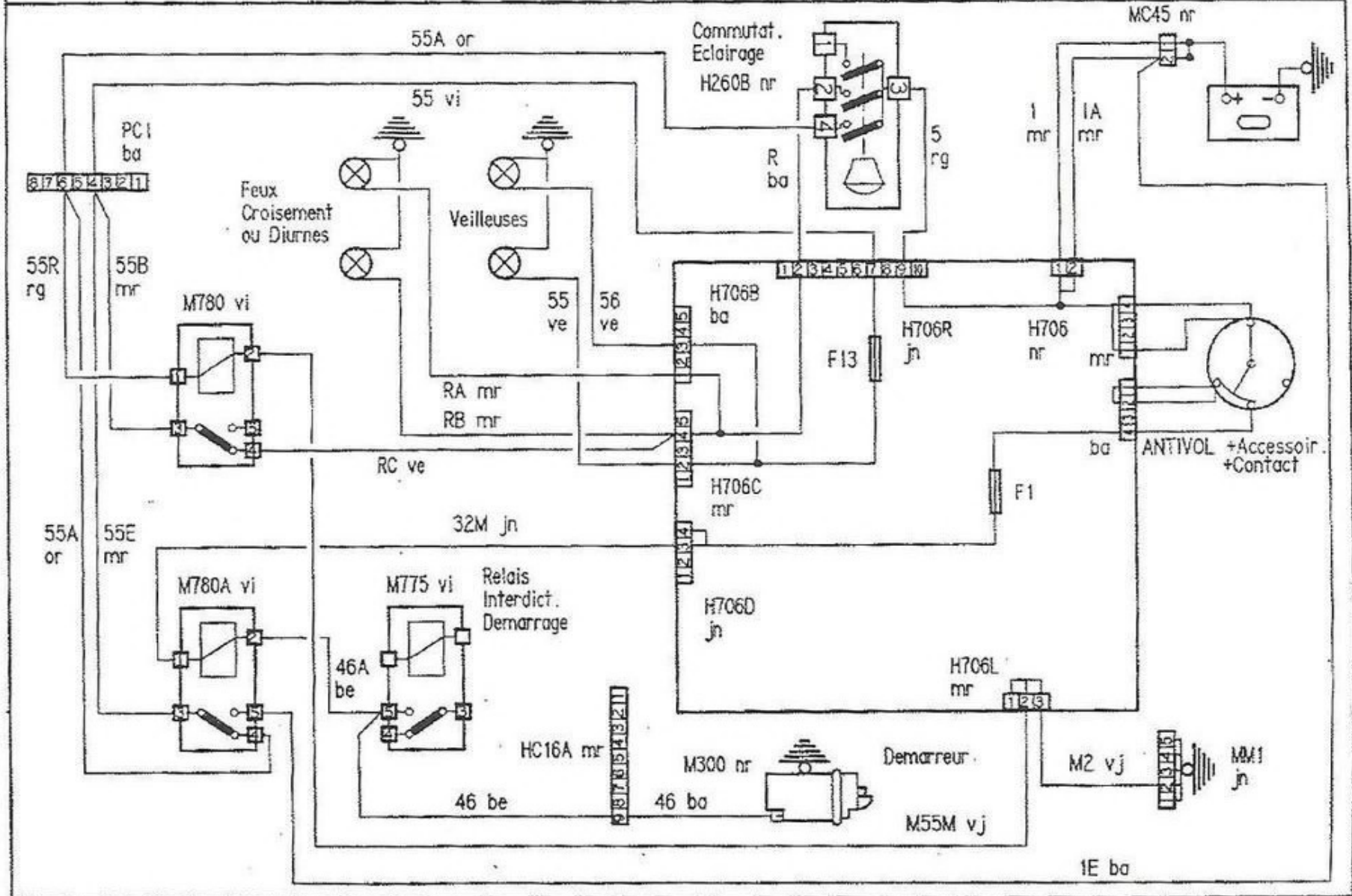

TYPES CONCERNES:
-205 DSL

FEUX DIURNES

39
2

A JOUR LE: 01-09-90

NOM: MOUTH

TEL: 4319

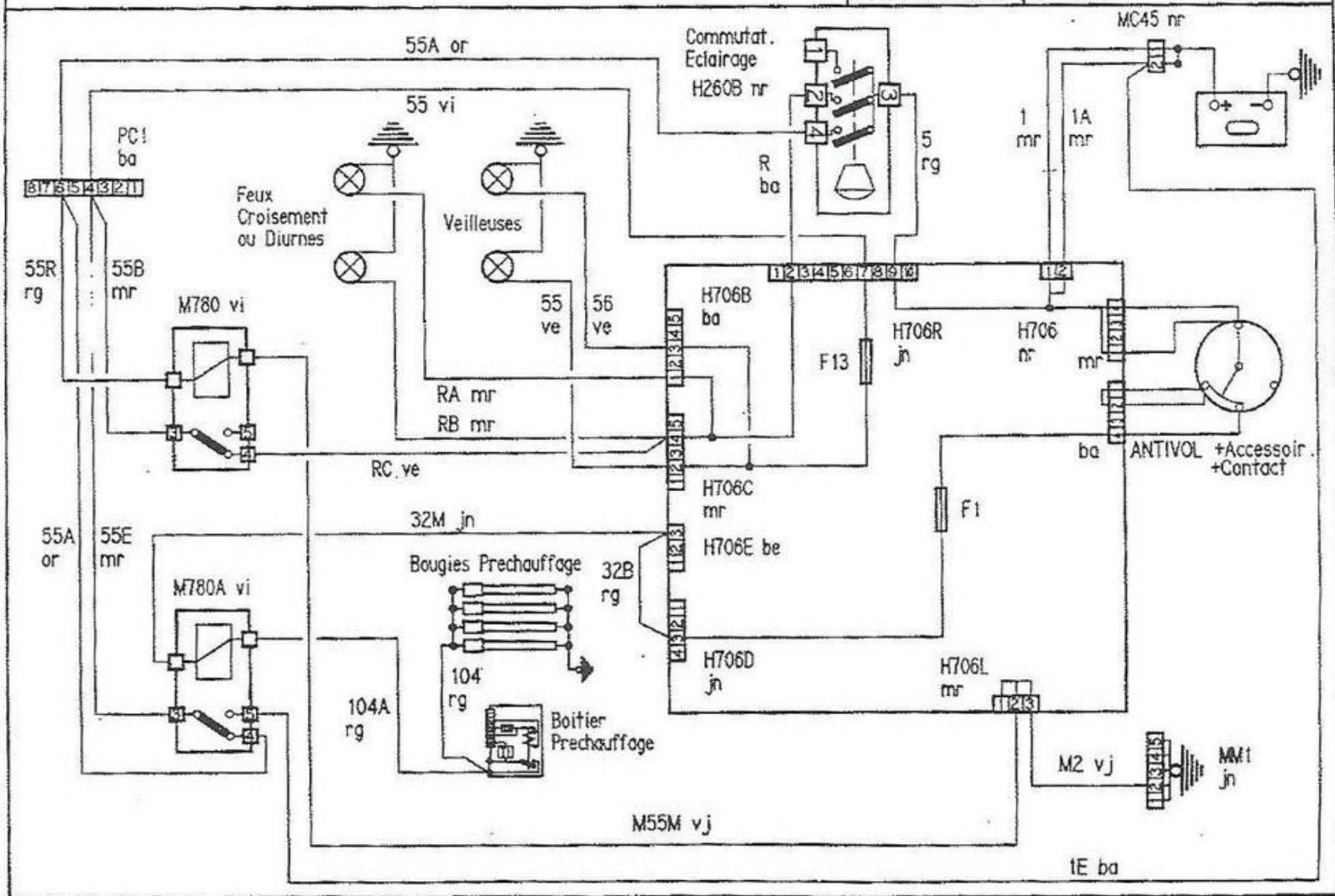

EN POINTILLES : Direction Droite

CAPOTE
ELECTRIQUE

40
2

A JOUR LE: 01-09-90

NOM: MOUTH

TEL: 4319

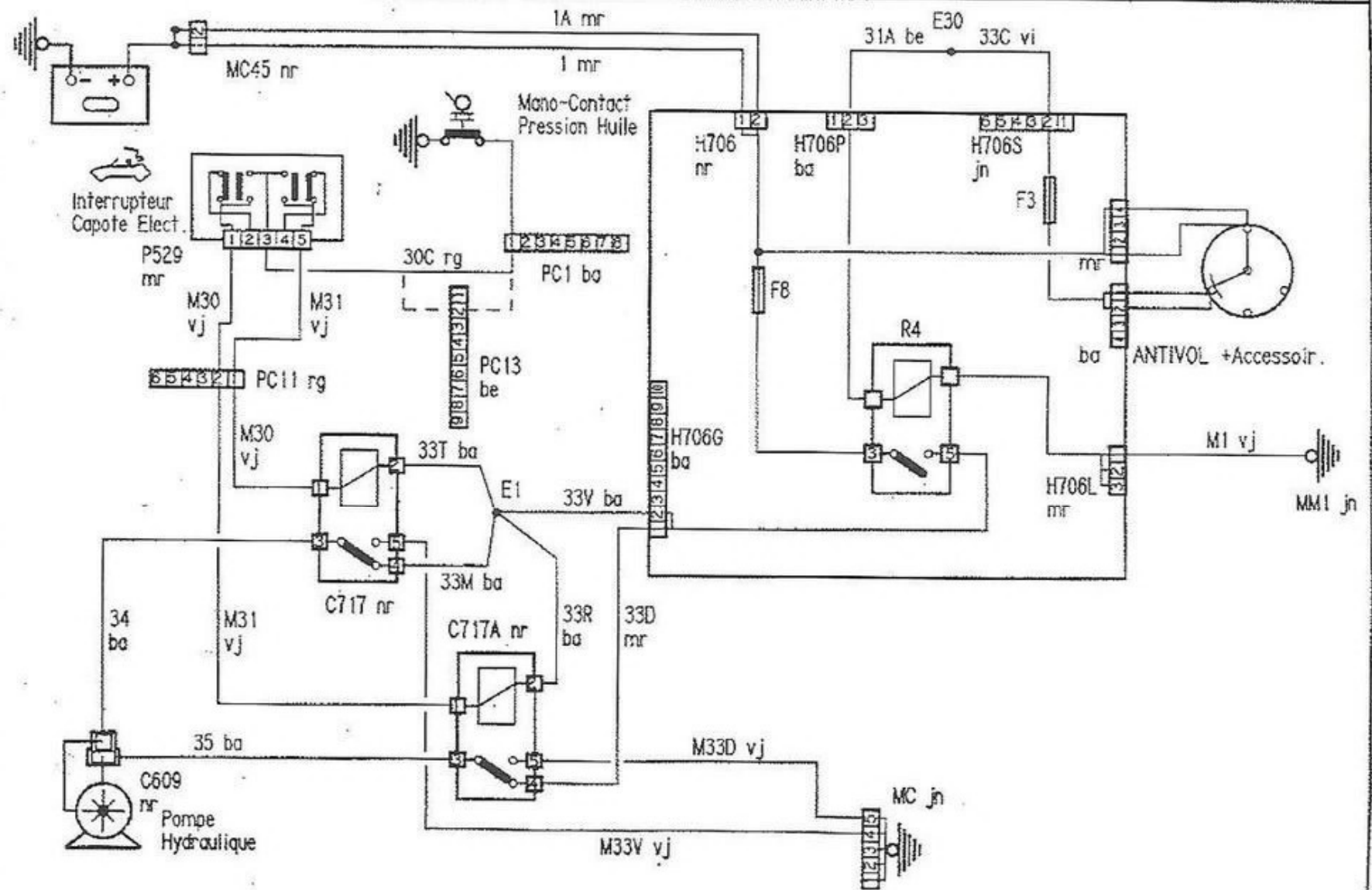

TYPES CONCERNES:
-205 DSL XUD9 EGR
(DEPOLLUES)

ANTIPOLLUTION DIES.
MOTEUR XUD9 EGR

41
4

A JOUR LE: 01-09-90

NOM: MOUTH

TEL: 4319

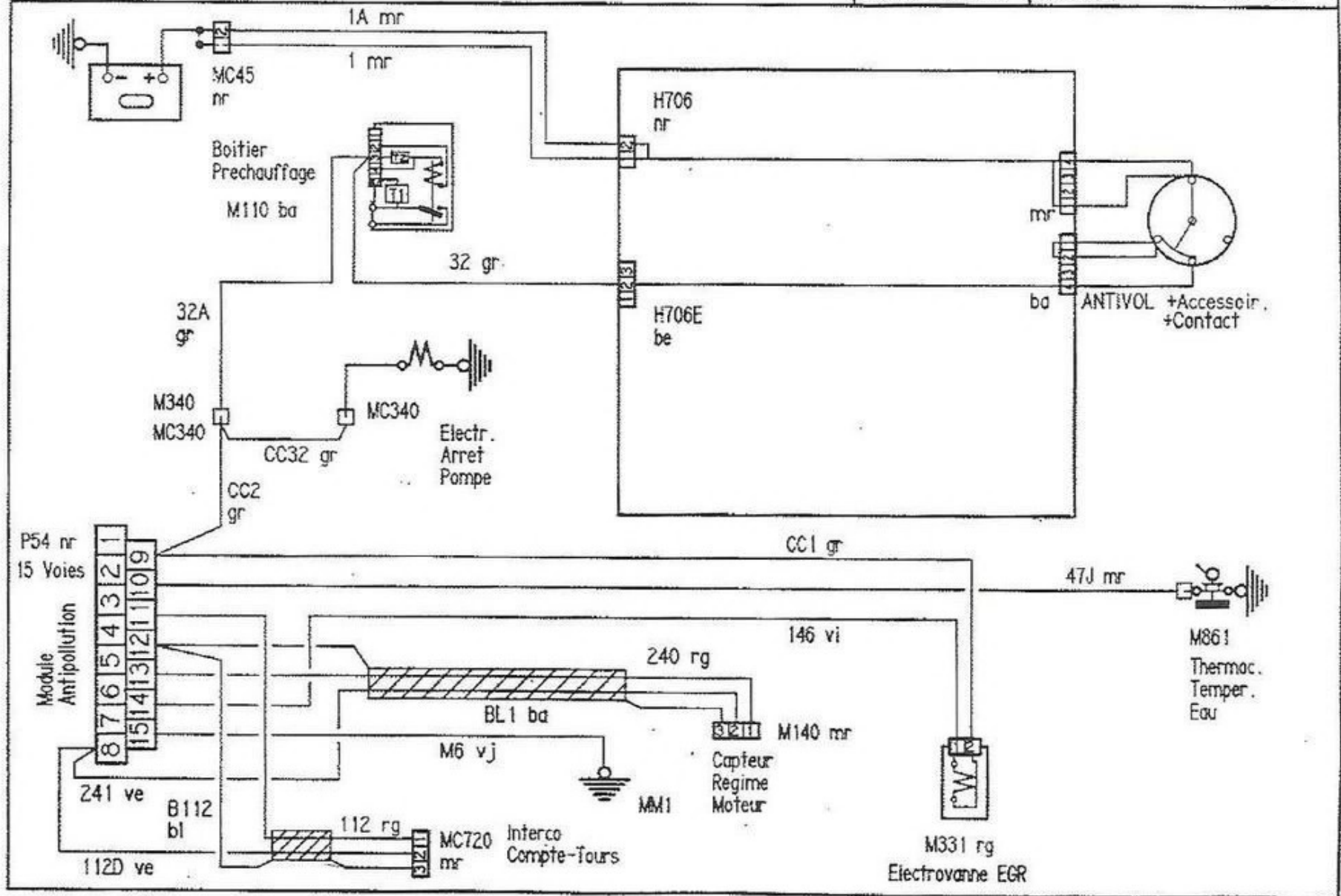

TYPES CONCERNES:
-205REFRI

REFRIGERATION

43

A JOUR LE: 01-09-90

NOM: MOUTH

TEL: 4319

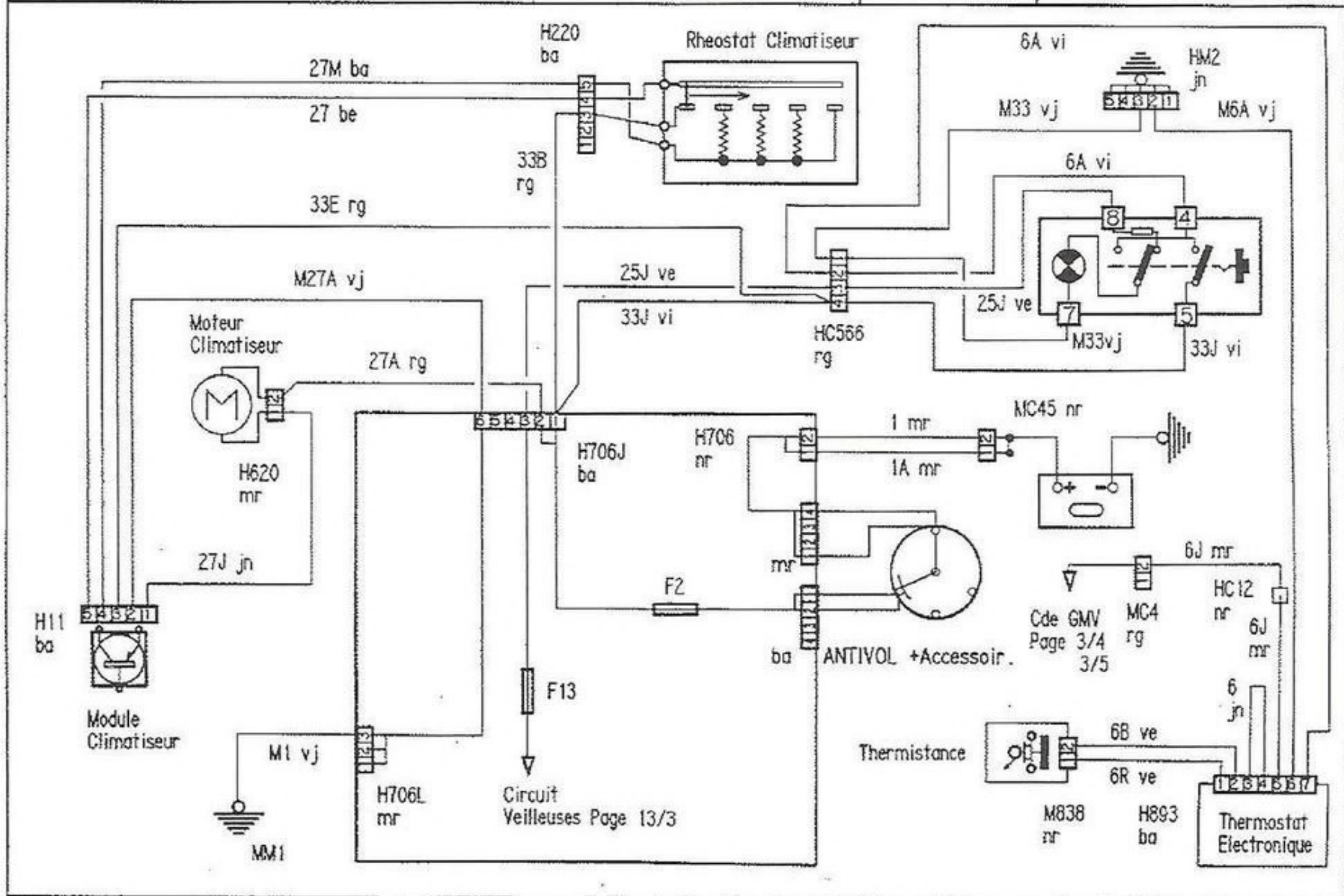

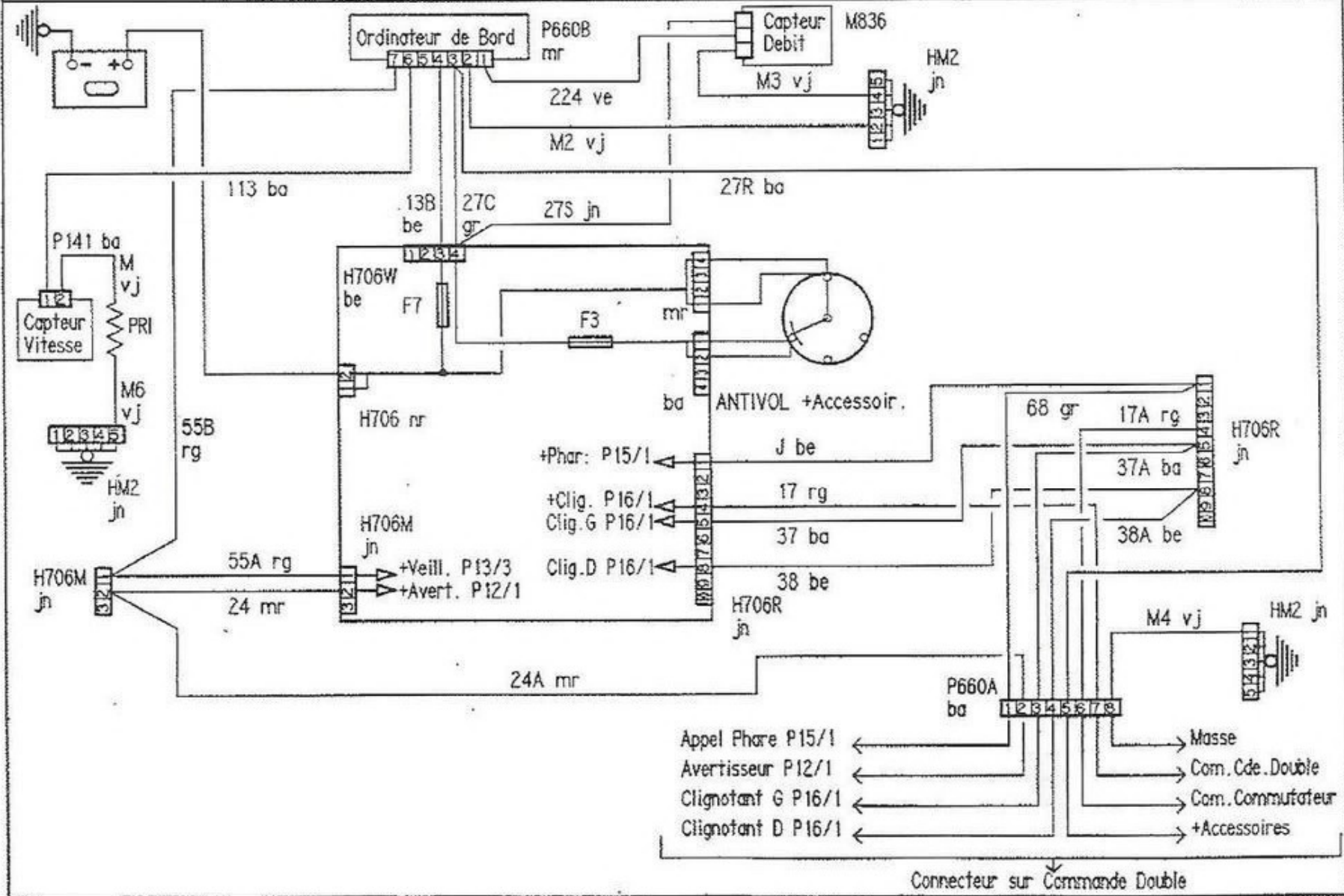

- Appel Phare P15/1 ←
- Avertisseur P12/1 ←
- Clignotant G P16/1 ←
- Clignotant D P16/1 ←
- Masse →
- Com. Cde. Double →
- Com. Commutateur →
- +Accessoires →

Connecteur sur Commande Double

FEUX "DIM-DIPS" = FEUX DE CIRCULATION URBAINE
NOCTURNE ATTENUES

FEUX "DIM-DIPS"

45
1

A JOUR LE: 01-09-90

NCM: MOUTH

TEL: 4319

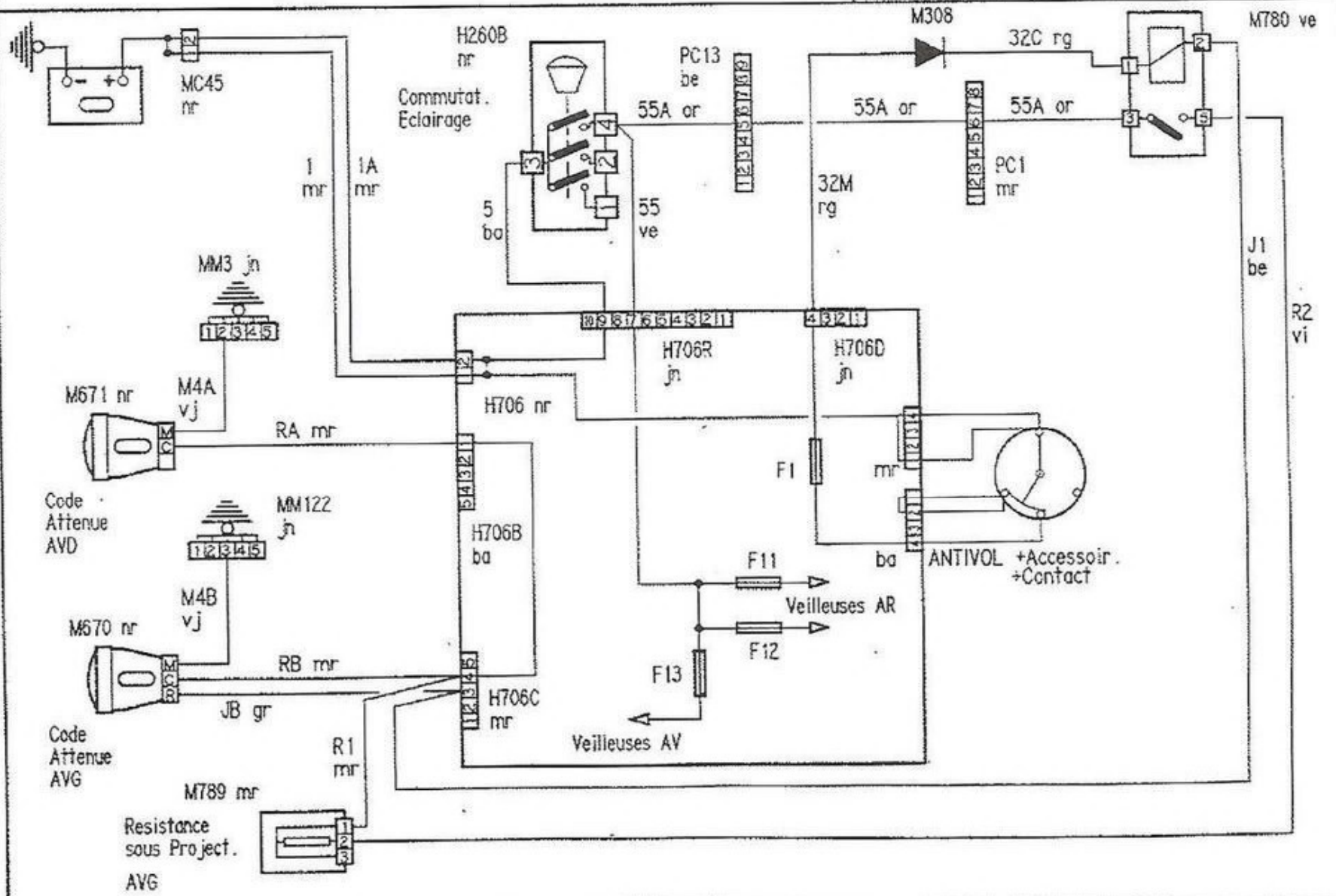

ANTIBLOCCAGE ROUES ADDONIX 4-2

46

A JOUR LE: 01-09-90

NOM: MOUTH

TEL: 4319

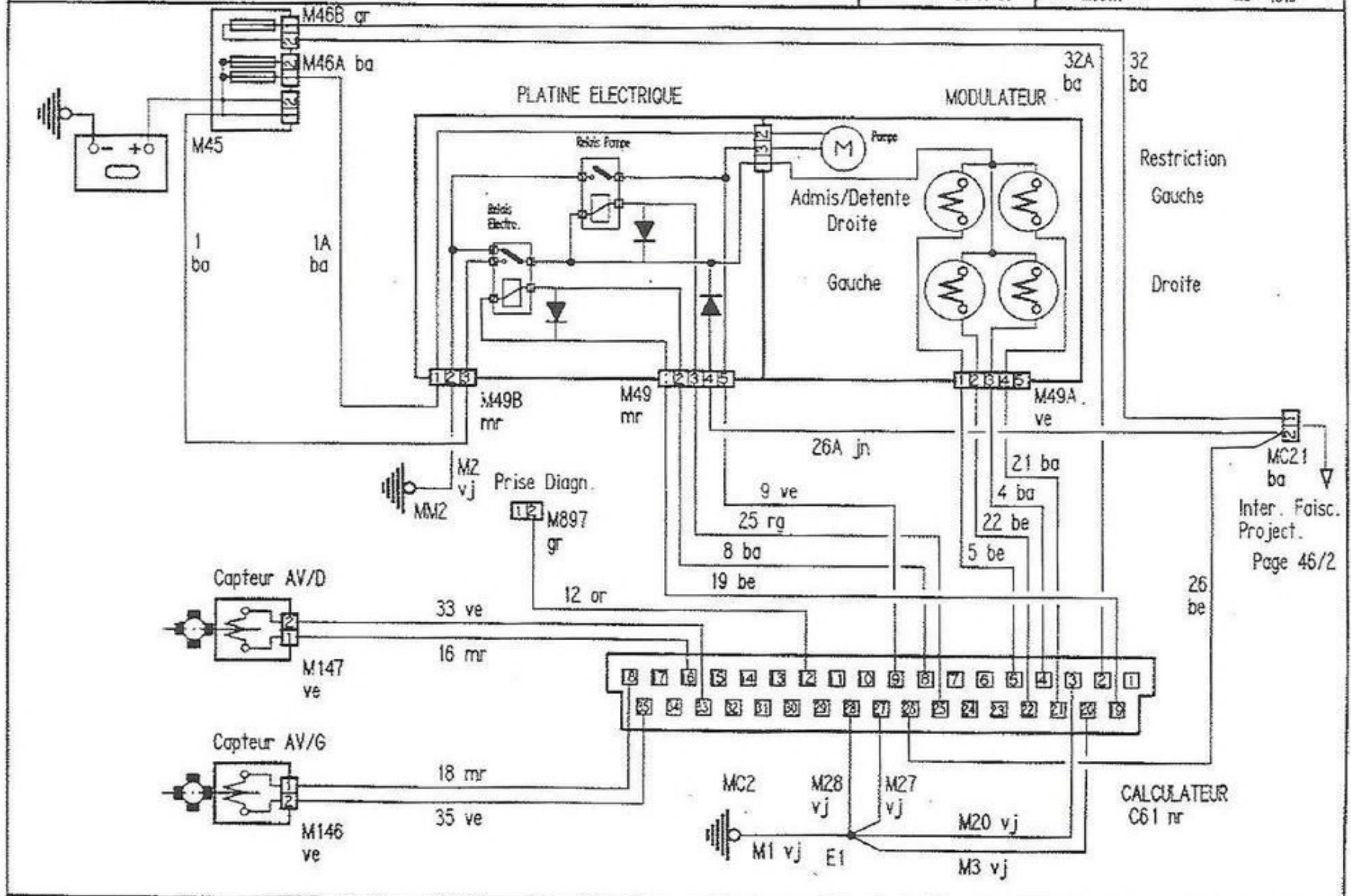

Inter. Faisc.
Project.
Page 46/2

TEMOIN AUTODIAGNOST. ANTIBLOCCAGE ROUES

46
2

A JOUR LE: 01-07-90

NOM: MOUTH

TEL: 4319

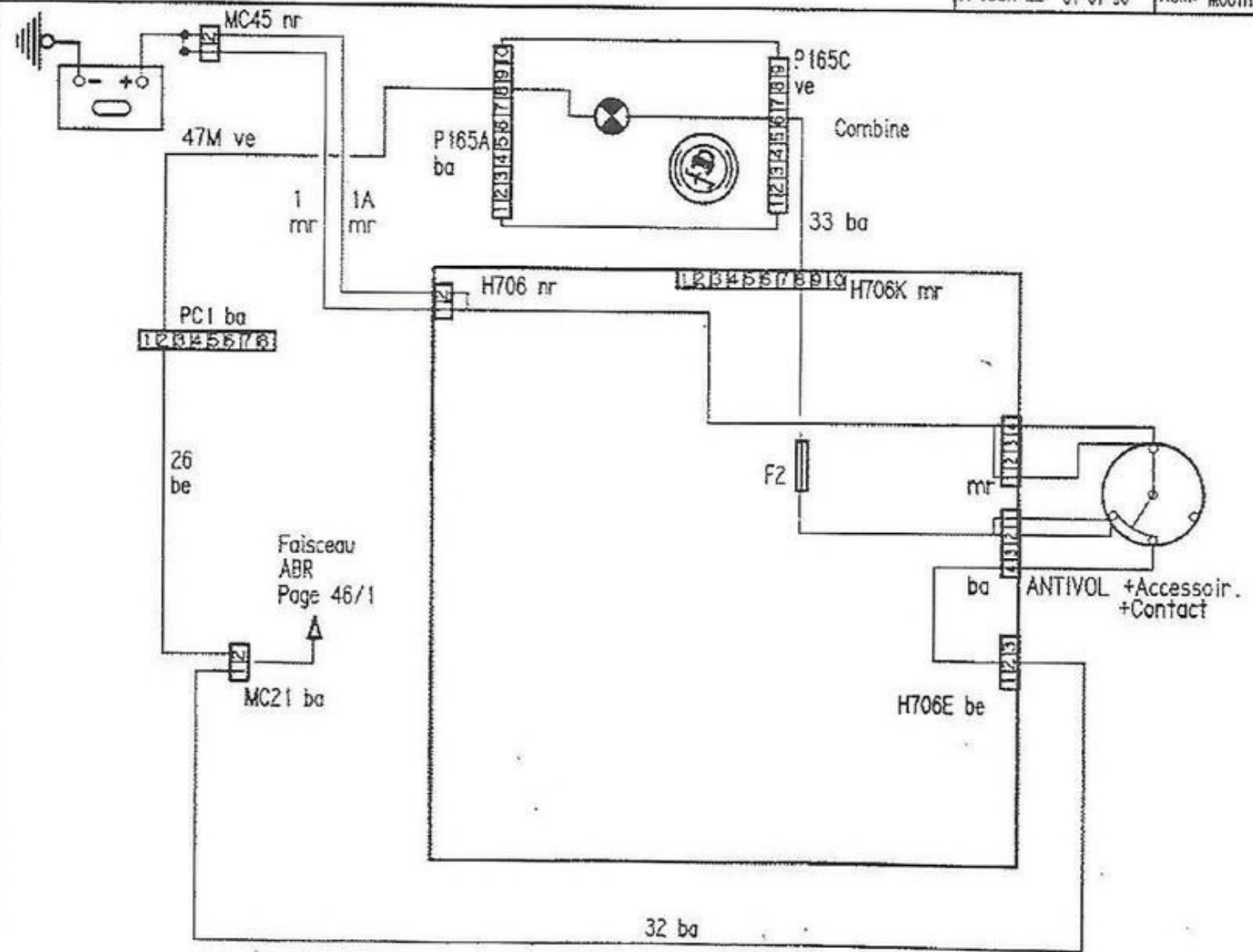

Faisceau
ABR
Page 46/1

FUSIBLE COMPRESSEUR : 20A
 FUSIBLE GIROPHARE : 7.5A

SURETE NATIONALE
 GENDARMERIE GT

46
 10

A JOUR LE: 01-09-90

MOY: MOYTH

TEL: 4318

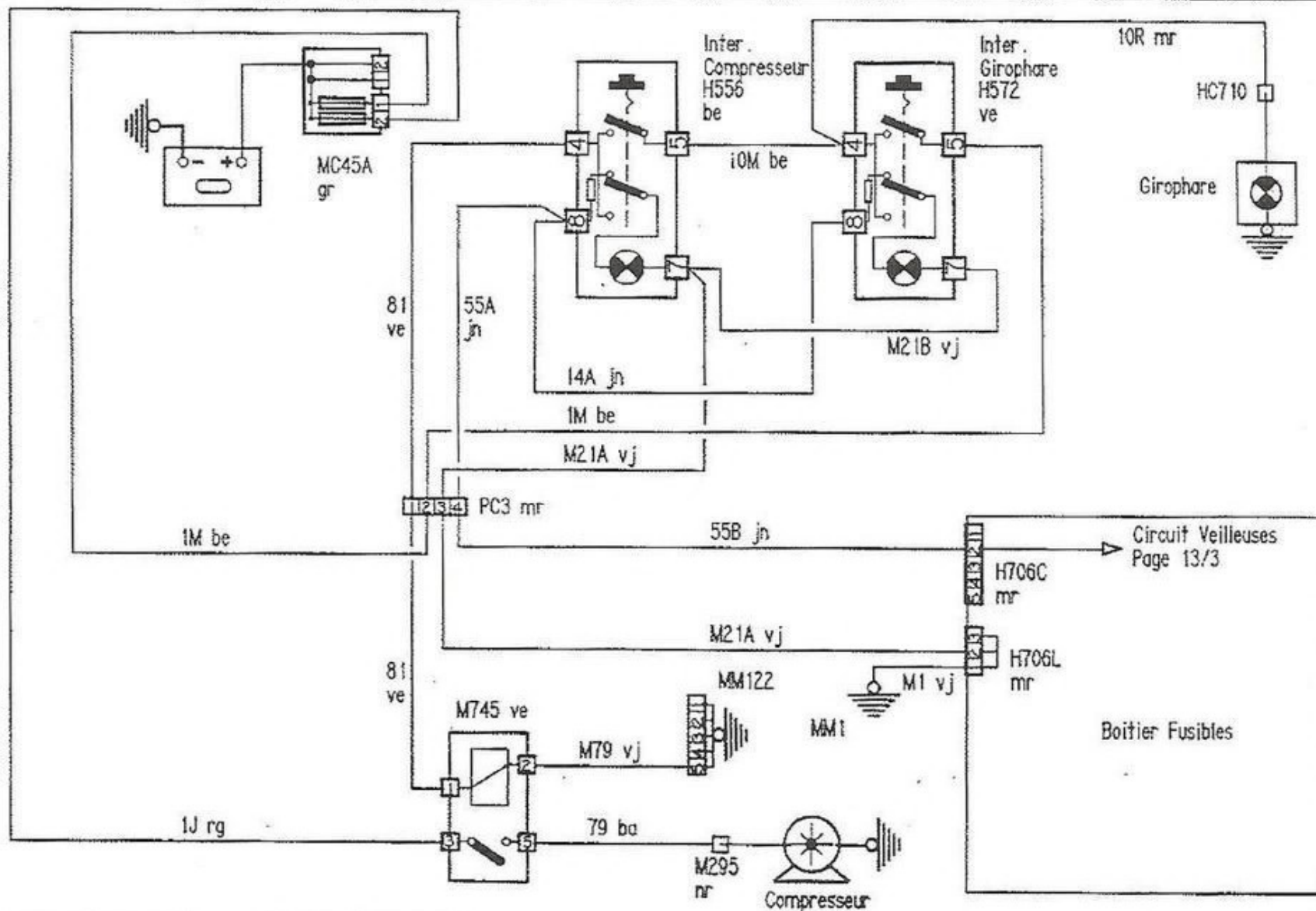

FUSIBLE EMETTEUR-RECEPTEUR : 7,5 Amp.

FUSIBLE COMPRESSEUR TROMPES : 20 Amp.

SURETE NATIONALE
NON BANALISEE

46
11

A JOUR LE: 01-09-90

NDM: MOUTH

TEL: 4319

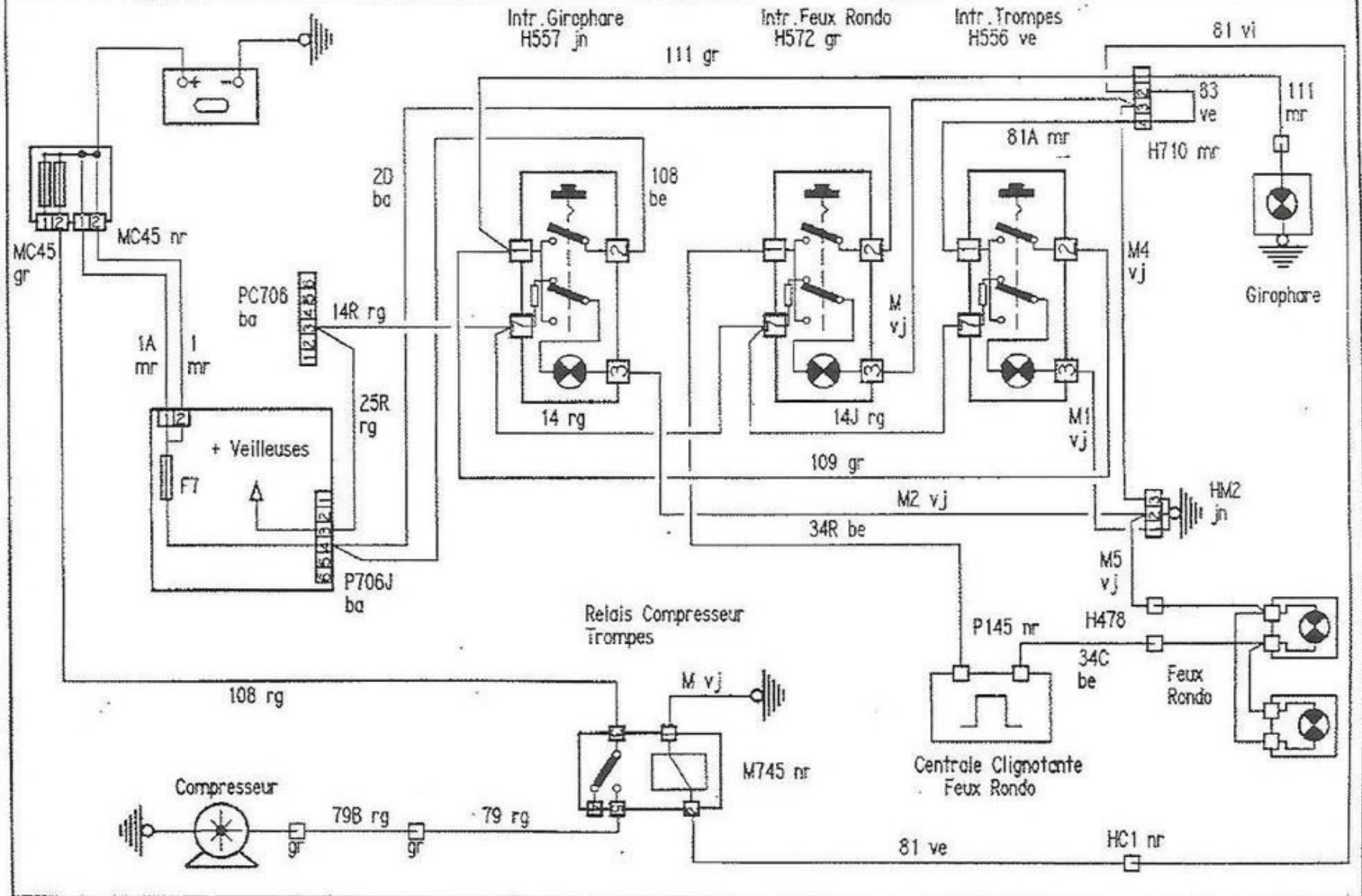

FUSIBLE COMPRESSEUR : 20A
 FUSIBLE GIROPHARE : 7.5A

SURETE NATIONALE
 GENDARMERIE GL

46/12

A JOUR LE: 01-09-90

NOM: MOUTH

TEL: 4319

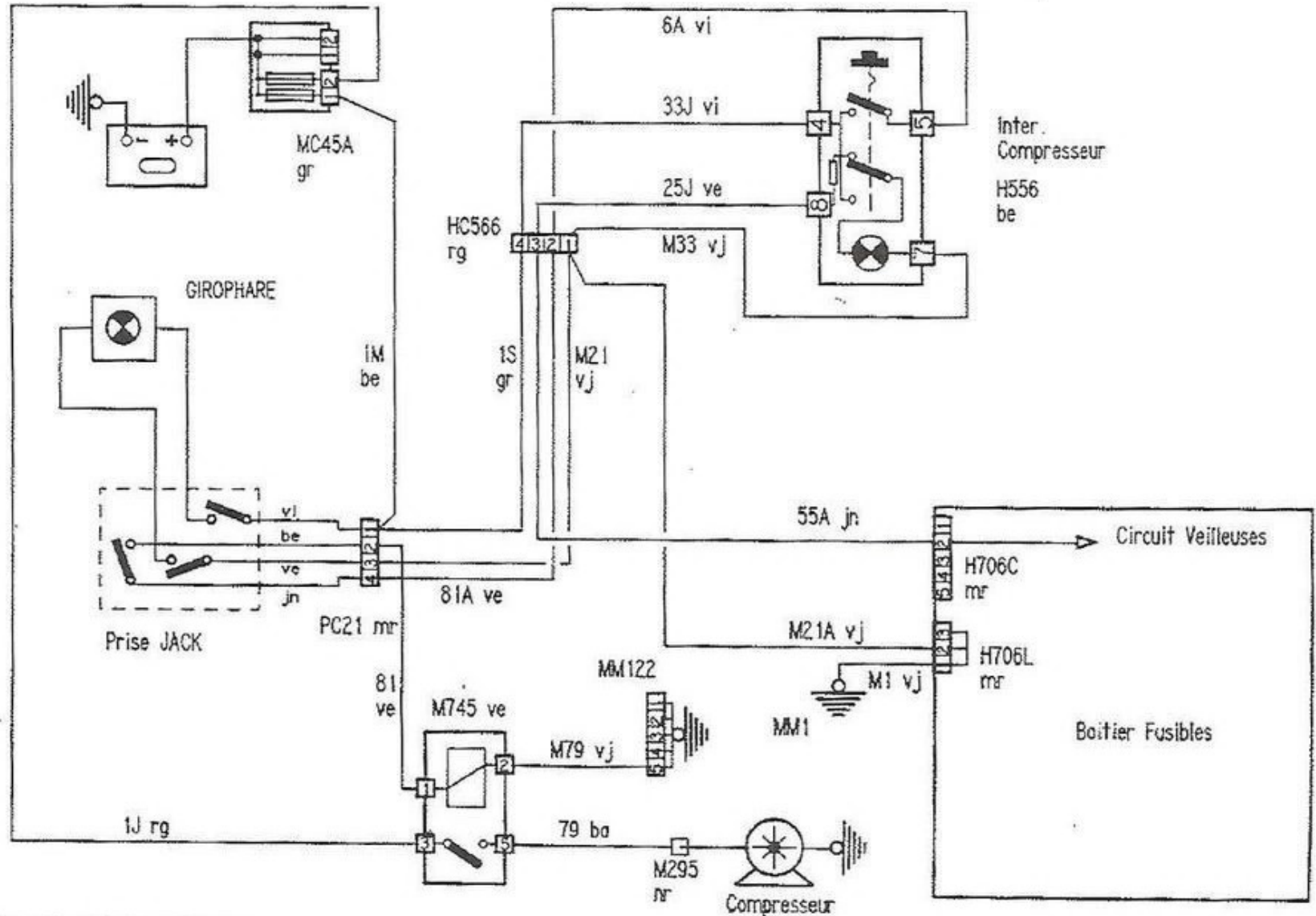

FONCTIONS PROTEGEES
PAR FUSIBLES

47
1

A JOUR LE: 01-09-90

NOM: MOUTH

TEL: 4319

FUSIBLES	INTENSITE	FONCTIONS
F1 + Contact	10	Temoins Charge Bat.(3Cadrans) -Temoins Presence EAU/GasOil(3Cadrans) -Compte-Tours -Ecl. Montre Digitale -Temoins BRAKE -Rechau. Carbu. -Sonde Surchauf. Cata -Feux Diurnes ou DIM-DIPS -Feux Recul
F2 + Accessoire	25	Tous les Temoins Combine non marques en F1 -Pompe a Eau Addition. -Bruifeur Veilleuses -Eclair. Vide Poche(DD) -Clignotants -Climatiseur -Sieges Chauffants -Allume Cigare(AUSTRALIE) -Frein a Main -Niveau Carburant
F3 + Accessoire	25	EV AV - Auto Radio -Lect.Cartes -Relais Leve Vitre -EV AR -Feux Stop -Lave Projecteurs -Ordi.Bord -Eclai.Vid.Poche(DG) Temoins Niveau Bas Essence(3Cadrans) -Relais Lunette Chauffante ou Relais Capote Elect. -Tempo Plafonnier
F4 + Permanent	15	Longues Portees
F5 + Permanent	10	Signal Danger
F6		
F7 + Permanent	25	Montre -Plafonnier -Aliment.Attache Remorque -Condamnation Centralisee -Eclaireur de Coffre -Auto Radio -Ordi.Bord Auto Ecole
F8 + Permanent	30	Avertisseur -Lunette Chauffante ou Pompe Hydraul. Capote Elect. -Allume Cigare (sf AUSTRALIE)
F9 + Permanent	25	Leves Vitre Electriques
F10 + Eclairage	5	Feu AR Brouillard
F11 + Eclairage	5	Feux de Position ARG Eclaireurs Plaque Police
F12 + Eclairage	5	Feu de Position ARD
F13 + Eclairage	5	Feux de Position AV -Eclairage Interrupteurs -Eclairage Climatiseur -Eclairage Combine
F14 + Contact	15	Pompe a Essence

BOITIER INTERCONNEXIONS

48

A JOUR LE: 01-09-90

NOM: MOUTH

TEL: 4319

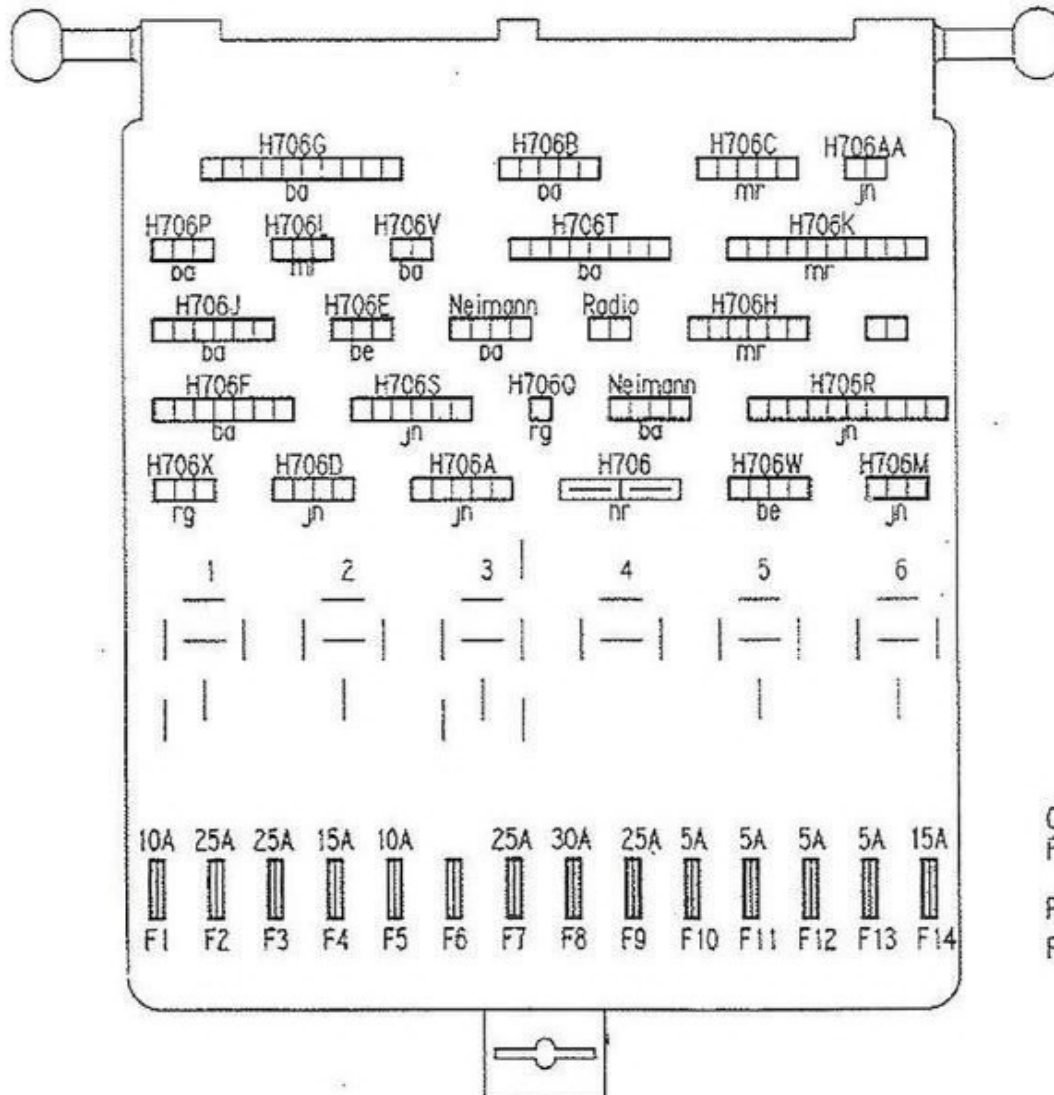

EMPLACEMENTS UTILISES :

1. RELAIS LONGUES PORTEES
- 2.
3. TEMPO OU CONNECTEUR PONT
4. CENTRALE CLIGNOTANTE
5. RELAIS LEVE VITRES AV
6. RELAIS LUNETTE AR CHAUFFANTE
ou CAPOTE ELECTRIQUE

Non Inverseur Imperativement

OPTION LEVE VITRES ELECTRIQUES:
FUSIBLE F9

POMPE IMMERGEE : F14

FEUX LONGUES PORTEES : F4

CONNECTEURS SUR BOITIER INTERCONNEX.

49/1

A JOUR LE: 01-09-90

NOM: MONTH

TEL: 4319

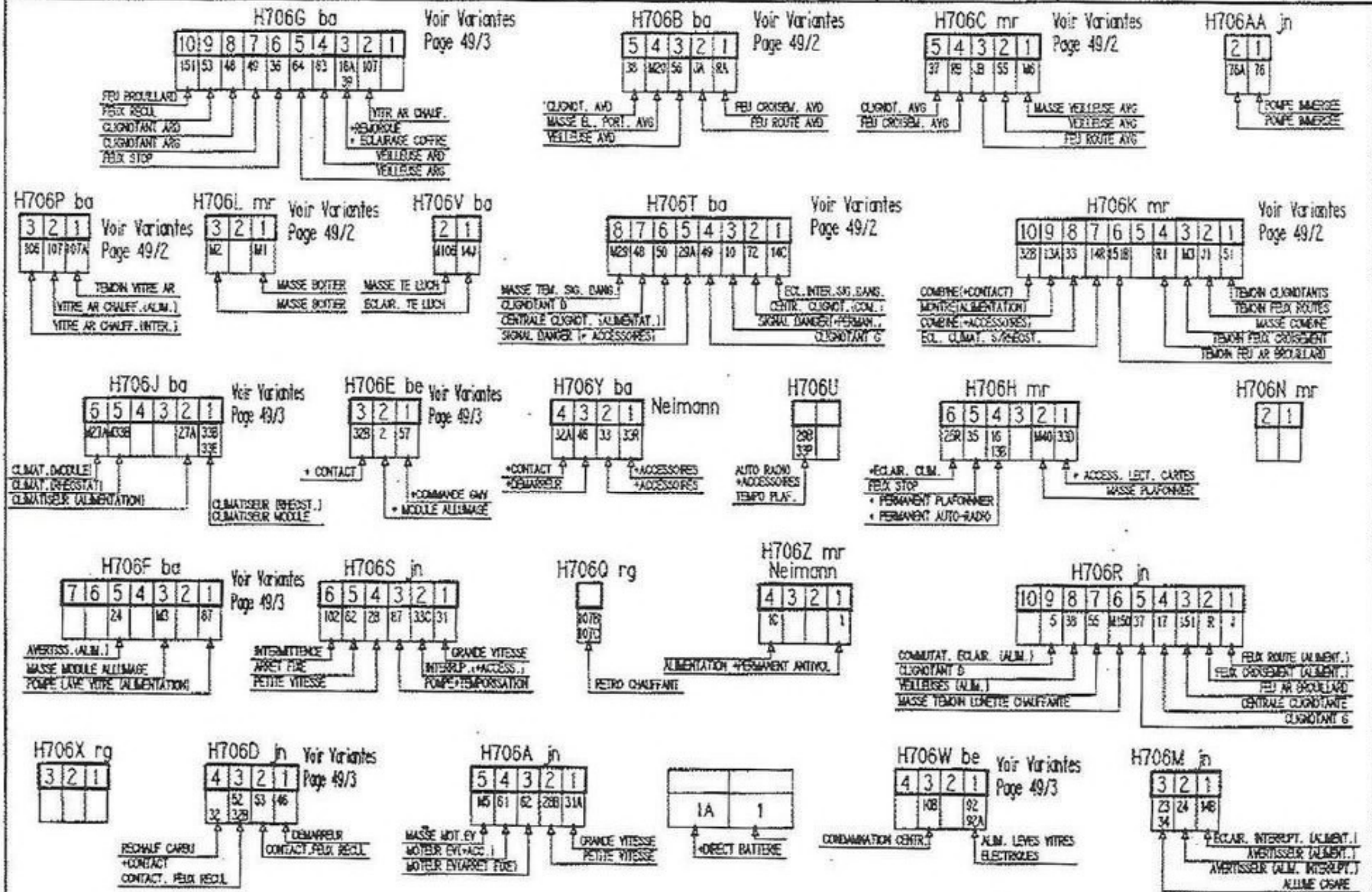

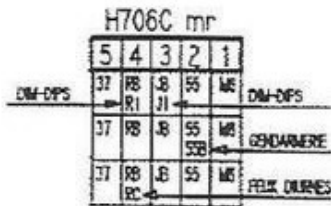
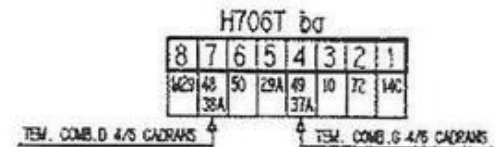
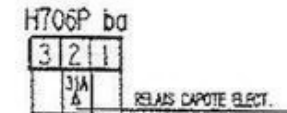
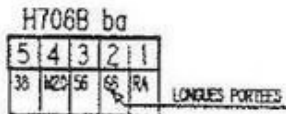

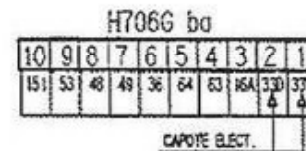
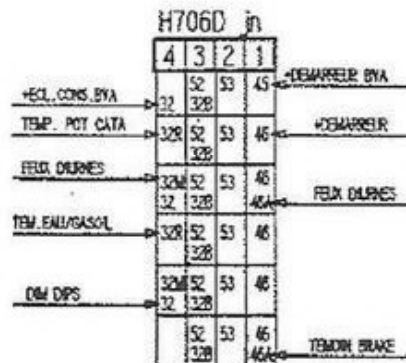
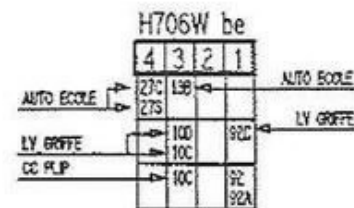
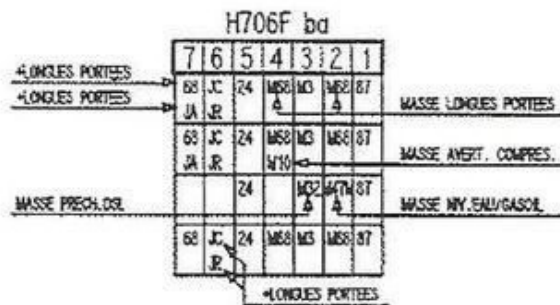
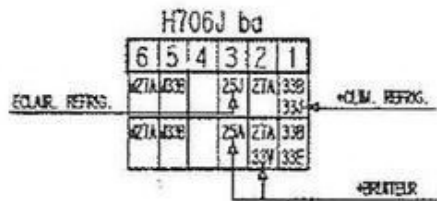

ABBREVIATIONS:

-CLM=FAISCEAU CLIMATISEUR
 -FPRJ=FAISCEAU PROJECTEUR
 -FAR=FAISCEAU FEUX AR

-PLAF=FAISCEAU PLAFONNIER
 -FPOG=FAISCEAU PORTE AVG
 -POB=FAISCEAU PLANCHE DE BORD

-FPOD=FAISCEAU PORTE AVD
 -FVAR=FAISCEAU VOLET AR

INTERCONNEXIONS SUR 50
 GARNITURE AUVENT G

A JOUR LE: 01-09-90

NOM: MOUTH

TEL: 3388

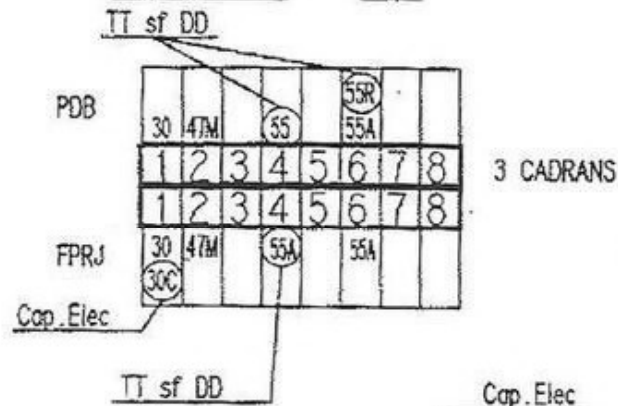
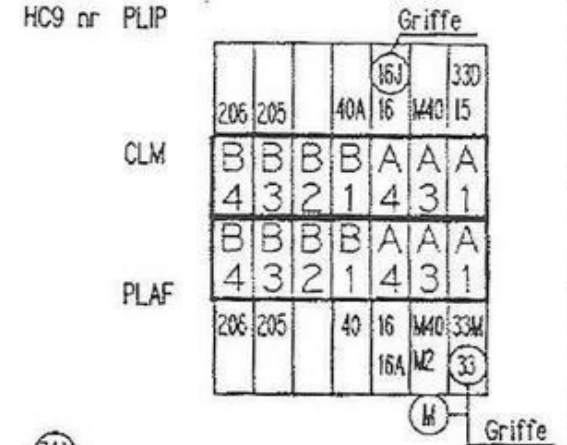
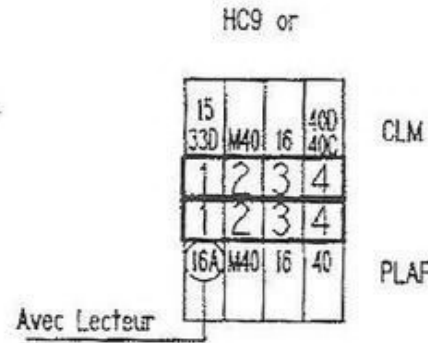
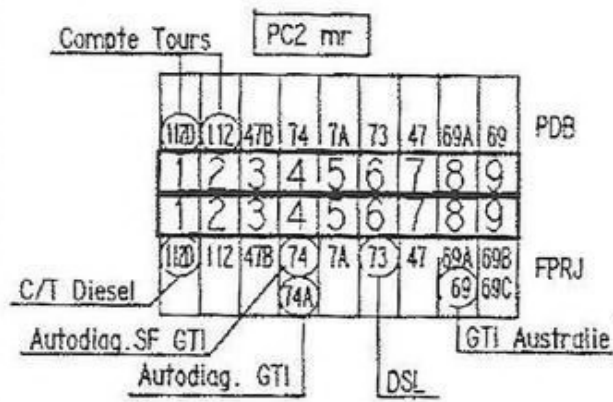

PC1 ba

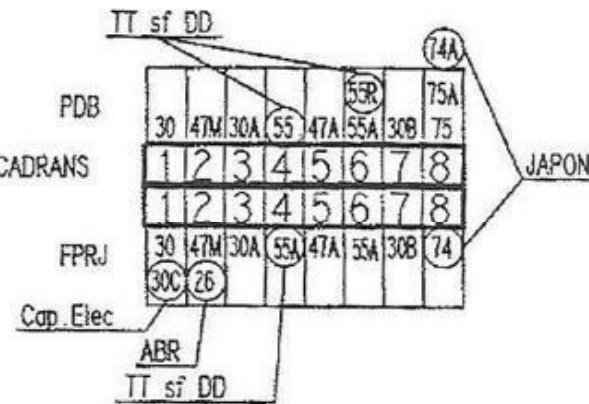

PDB
 CLIM en DD

FAR

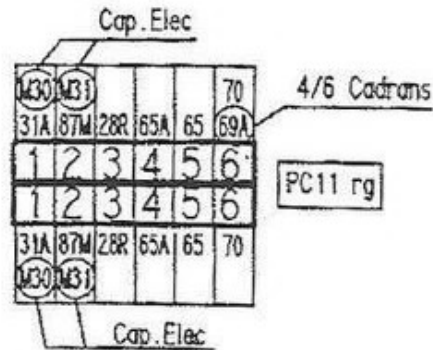

TYPES CONCERNES:
-205 4/6 Cadrans

CONNECTEURS SUR COMBINE

51

A JOUR LE: 01-09-90

NOM: MOUTH

TEL: 4319

P165D be
Faisceau PdB

1	2	3	4	5	6	7
7A	70	37A	55R	R1		

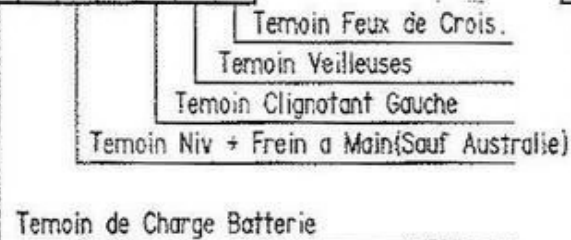

P165 jn
Faisceau PdB

1	2	3	4	5	6	7	8
73	30	69	J1	10A	65	65A	

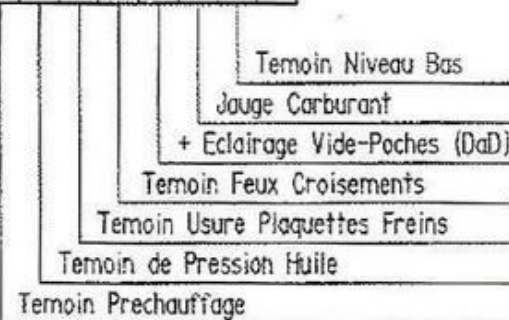

P165C ve
Faisceau PdB

1	2	3	4	5	6	7	8	9
	13B	25	M25	75	33	47B		38A
				74A				



P165A ba
Faisceau PdB

1	2	3	4	5	6	7	8	9	10
	30B		47		47A	30A	47M	74	M3

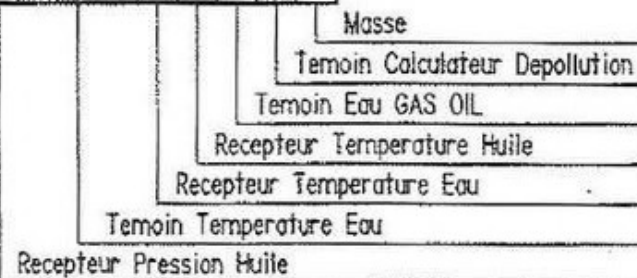

P165B be
Faisceau PdB

1	2	3	4
32B	M32B	112	112D
32			

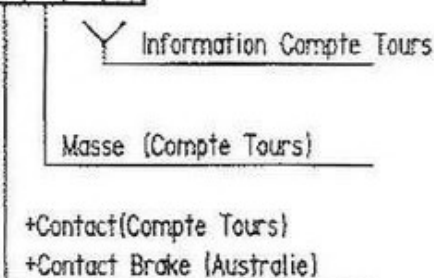

Specifique
Australie

P165E ba
Faisceau PdB

1	2
70	32

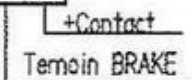

TYPES CONCERNES:
-205 3 Cadrons

CONNECTEURS SUR COMBINE

51/2

A JOUR LE: 01-09-90

NOM: MOJTH

TEL: 4319

P165A ba
(Faisceau PdB)

1	2	3	4	5	6	7	8	9	10
70	51	M25	M3	J1	R1	55R		13A	33

- +Accessoires
- Montre Aiguilles
- Temoin Feux de Position
- Temoin Feux de Croisement
- Temoin Feux de Route
- Masse Combine
- Eclairage Combine (Masse)
- Temoin Clignotants
- Temoin de Frein A Main

P165C ve
(Faisceau PdB)

1	2	3	4	5	6	7	8	9
75	74	65		14 25		47M32B		

- +Contact
- Eau dans Gasoil(DIESEL)
- Eclairage Combine(14 sans Rheost..25 avec)
- Jauge Carburant
- Temoin Calculateur Depollution
- Starter (ESSENCE)

P165 JN
(Faisceau PdB)

1	2	3	4	5	6	7	8
	30	7A	73	47	10A	69A	

- Temoin Niveau Locked
- + Eclairage Vide-Poches (DaD)
- Temoin Temperature Eau
- Temoin Prechauffage Bougies(DIESEL)
- Temoin de Charge Batterie
- Temoin Pression Huile

P165D gr
(Faisceau PdB)

1	2	3	4	5	6
69	47B	33B		165A	

- Temoin Niveau Bas Carburant
- + Accessoires
- Temoin Niveau d'Eau
- Temoin Usures Plaquettes

ABREVIATIONS:

-CLM=FAISCEAU CLIMATISEUR
 -FRJ=FAISCEAU PROJECTEUR
 -FAR=FAISCEAU FEUX AR

-INJ=FAISCEAU INJECTION
 -FPOG=FAISCEAU PORTE AVG
 -PDB=FAISCEAU PLANCHE DE BORD

-FPOD=FAISCEAU PORTE AVD
 -FVAR=FAISCEAU VOILET AR

CONNECTEURS + INTERCONNEXIONS

52 / 2

A JOUR LE: 01-09-90

NOM: MOUTH

TEL: 4319

COM. ESSUIE VITRE AVANT
 H263 nr

	1	2	3	4	5	6	7
PdB (ou CLM en DD)	10Z	61A	31	28	62	33A	87

COM. ESSUIE VITRE ARRIERE
 H263A ve

	1	2	3
PdB (ou CLM en DD)	33M	87M	28R

PC13 be (Specifique DD)
 (Au dessus Boitier Interconn.)

CLM	34	30C	65	65A	55A	M150	150	151	70
	1	2	3	4	5	6	7	8	9
PdB	34	30C	65	65A	55A	M150	150	151	69A 70

Capot Elec

3 Cadrons
 (+ VEILLEUSES)
 RALLYE

			25		
	14M	14B	14	14R	
	1	2	3	4	5

FIXE SUR PDB
 PC15 nr

4/6 Cadrons
 (+ VEILLEUSES)

			14R	55R	
	14A	14M	14B	14	14R
	1	2	3	4	5

COM. PHARES
 H260B nr

	1	2	3	4
PdB (ou CLM en DD)	J	R	5	55B 55A

COM. AVERT./CLIGNOT.

H260A nr

	1	2	3	4	5	6
PdB (ou CLM en DD)	24	150	23	38	17	37

SUR AUVENT D
 (CLIM COTE D EN DD)
 HC16A nr

	15								46
INJ	52	53	47	47A	7A	30	30A	30B	46B
	1	2	3	4	5	6	7	8	9
FRPJ	52	53	47	47A	7A	30	30A	30B	46

SUR AUVENT D
 (CLIM COTE D EN DD)
 HC16 nr

	98	M	120	15A	32A	
INJ	47B	76	47B	12B	15	2A
	1	2	3	4	5	6
FRPJ	47B	76	M3	112	74A	2

SEULEMENT EN DG

ABREVIATIONS: -CLM=FAISCEAU CLIMATISEUR
 -FPRJ=FAISCEAU PROJECTEUR
 -FAR=FAISCEAU FEUX AR

-INJ=FAISCEAU INJECTION
 -FPOG=FAISCEAU PORTE AVG/AVD
 -PDB=FAISCEAU PLANCHE DE BORD

-FPAD=FAISCEAU PORTE APD/ARG
 -FVAR=FAISCEAU VOLET AR

CONNECTEURS + INTERCONNEXIONS

52
1

A JOUR LE: 01-09-90

NOM: MOUTH

TEL: 8388

FEU ARG
C445 mr

1	2	3	4	5	6
M1	36A	53	151	49	64

FEU ARD
C446 mr

1	2	3	4
63	36B	48	M2

FAR

107	M39
1	2
1	2

CC170 jn
FEU ARG

FVAR

107	M39
-----	-----

FAR

200B	201A
1	2
1	2

5 PORTES
HC628 mr
Fourreau
Porte ARG

FVAG

200	201
-----	-----

FAR

31A	28R
1	2
1	2

CC171rg
FEU ARG

FVAR

31A	28R
-----	-----

FAR

200C	201B
1	2
1	2

5 PORTES
HC627 mr
Fourreau
Porte ARD

FPAD

200	201
-----	-----

3 PORTES

200	201
1	2
1	2

FAR

CC172 ba
FEU ARG

FVAR

200	201
-----	-----

5 PORTES

201B	
200	201
1	2
1	2

FAR

CC172 ba
FEU ARG

FVAR

200	201
-----	-----

SOUS PDB G
PC5 nr
PLIP

M10	203	204	92	94	96	107B
A	A	A	A	B	B	B
1	2	3	4	1	2	3
A	A	A	A	B	B	B
1	2	3	4	1	2	3

CLM

FPOG

M9	203	204	92	94	96	107B
----	-----	-----	----	----	----	------

SUR AUVENT D
PC5A nr

M9				92A	94	96	107C
A	A	A	A	B	B	B	B
1	2	3	4	1	2	3	4
A	A	A	A	B	B	B	B
1	2	3	4	1	2	3	4

CLM

FPOG

M9	203	204	92	94	96	107B
----	-----	-----	----	----	----	------

SOUS PDB G
PC3 jn

200	201A
200A	201
1	2
1	2

CLM

FAR

200A	201
	201A

SOUS PDB G
PC6 mr

211	211A	200A	201A
1	2	3	4
1	2	3	4

CLM

FPOG

211	211A	200	201
-----	------	-----	-----

SUR AUVENT D
PC6A mr

212	212A	200	201
1	2	3	4
1	2	3	4

CLM

FPOG

211	211A	200	201
-----	------	-----	-----

NUMEROTAT. APPAREILS 53
 ABREVIATIONS 1

A JOUR LE: 01-09-90

NOM: MOUTH

TEL: 4319

NUMEROTATIONS DES APPAREILS:

1

LES APPAREILS SONT NUMEROTES DE 1 A 999 POUR TOUS LES TYPES DE VOITURES

ON DIVISE LA VOITURE EN 4 COMPARTIMENTS PAR DES LETTRES (M.P. H.C.) QUE L'ON PLACE DEVANT LE REPERE NUMERIQUE EN FONCTION DE L'EMPLACEMENT GEOGRAPHIQUE DE L'APPAREIL

M MOTEUR

P PLANCHE DE BORD

H HABITACLE

C COFFRE

EXEMPLE: AVERTISSEUR REPERE NUMERIQUE 25

PLACE DANS LE COMPARTIMENT MOTEUR LA CONNEXION S'APPELLERA M25

2

POUR LES INTERCONNEXIONS ENTRE FAISCEAUX ON UTILISE LES LETTRES (M.P.H.C.) POUR DEFINIR L'EMPLACEMENT GEOGRAPHIQUE: PUIS FAIRE PRECEDER LE NUMERO D'ORDRE DE CONNEXION PAR LA LETTRE C

EXEMPLE: CONNEXION ENTRE FAISCEAU PLANCHE DE BORD ET MOTEUR DANS LE COMPARTIMENT MOTEUR MC1

3

POUR LES PRISES DE MASSES MEME PRINCIPE QUE PARAGRAPHE 2 MAIS FAIRE PRECEDER LE NUMERO D'ORDRE DE LA PRISE DE MASSE PAR LA LETTRE M
 EXEMPLE: PRISE DE MASSE SUR LE MOTEUR MM1

ABREVIATIONS DES COULEURS:

-OR: ORANGE

-VE: VERT

-BE: BLEU

-BA: BLANC

-MR: MARRON

-JN: JAUNE

-RG: ROUGE

-GR: GRIS

-VI: VIOLET

-VJ: VERT JAUNE

-RS: ROSE

-BG: BEIGE

ABREVIATIONS DES TYPES:

-ESS: ESSENCE

-DSL: DIESEL

-GTI: INJECTION

IMPLANTATION DES PLUS

54

A JOUR LE: 01-09-90

NOM: MOUTH

TEL: 4319

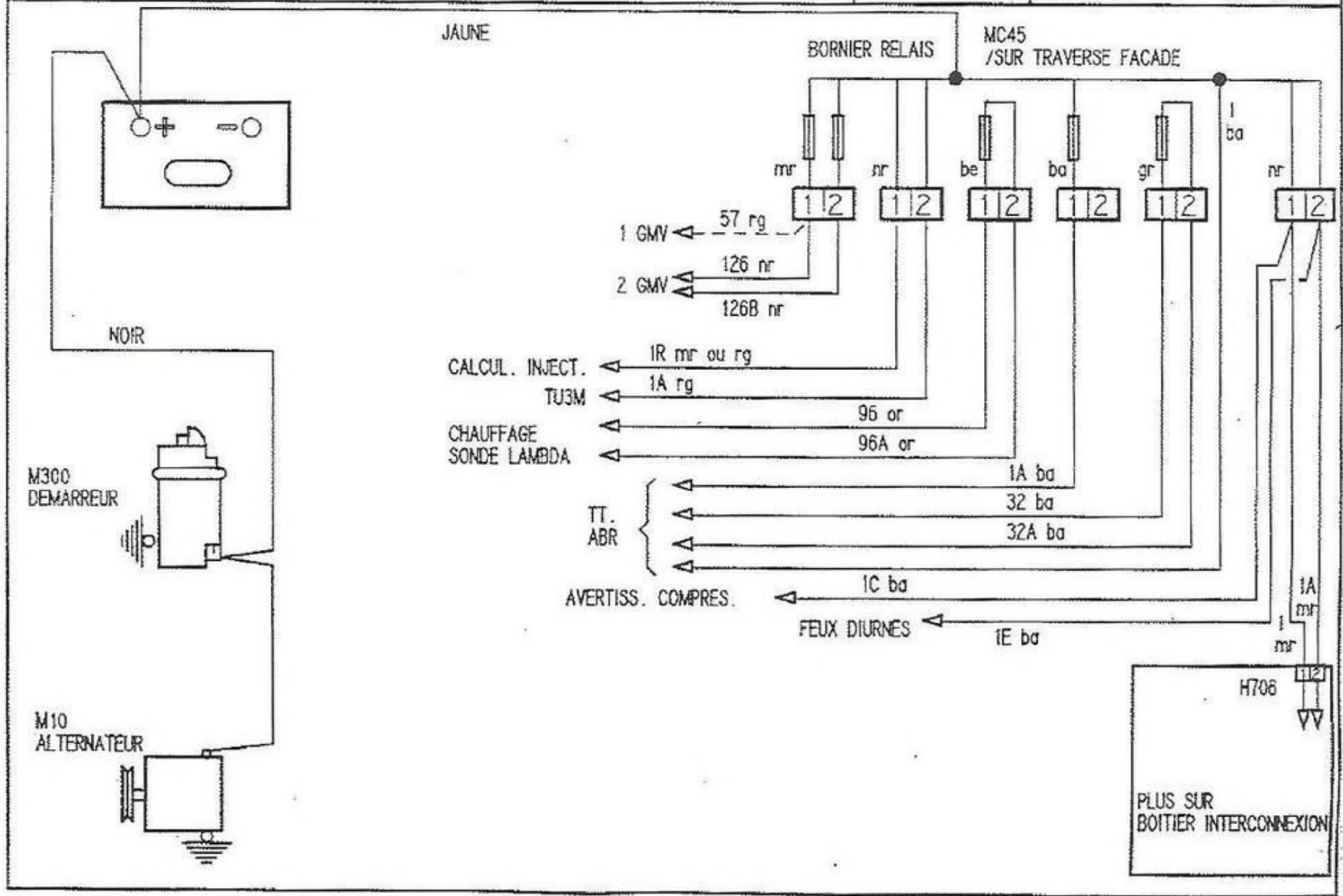

IMPLANTATION DES MASSES

54
2

A JOUR LE: 01-09-90

NOM: MOUTH

TEL: 4319

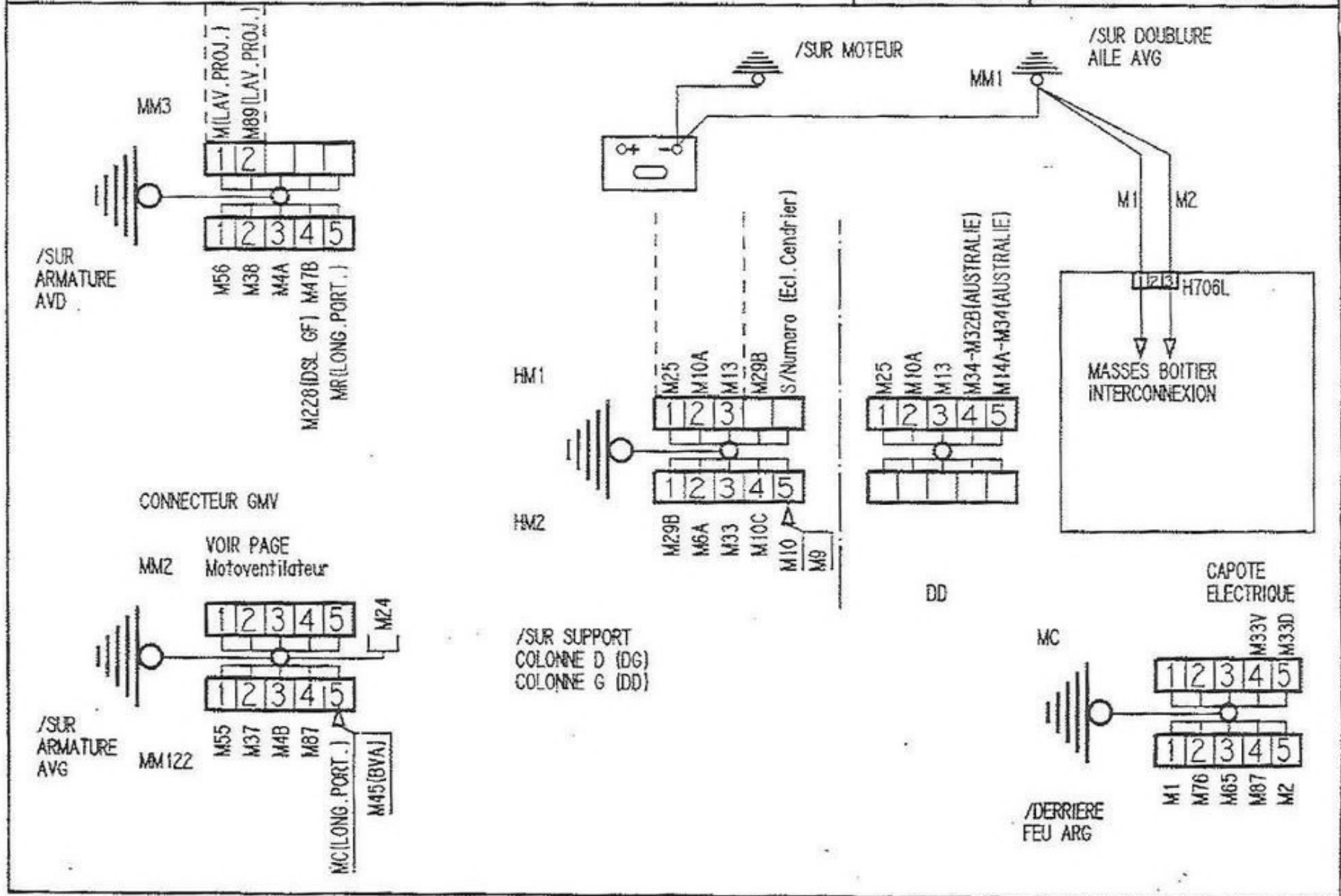

NOMENCLATURES DES FILS

56
2

A JOUR LE: 01-09-90

NOM: MOUTH

TEL: 4319

Numero Couleur	PAGES	Numero Couleur	PAGES	Numero Couleur	PAGES	Numero Couleur	PAGES	Numero Couleur	PAGES	Numero Couleur	PAGES
27 be	21/1, 43/1	29A rg	16/1	301 ba	2/4	32 jn	1/2, 2/1	32J jn	6/2	33A vi	18/1, 18/2, 31/1
27 mr	2/5	29B be	24/1	302 ba	2/4	32 rg	29/2, 29/3, 29/4	32J rg	7/1, 7/5	33B ba	8/1, 32/1
27 rg	2/1	2A gr	2/1	303 ba	2/4	32 rg	29/5, 29/6	32M jn	29/3, 29/4, 39/1	33B rg	21/1, 43/1
27A mr	29/6	2A or	2/1	30A ba	11/1	32 vi	2/3	32M jn	39/2, 39/3, 39/4	33C vi	8/1, 18/1, 18/2
27A rg	21/1, 43/1	2A rg	2/2, 2/3, 2/5	30A bg	7/5	32A ba	46/1	32M rg	7/1, 45/1	33C vi	25/5, 32/1, 34/1
27B ba	5/1, 5/2, 9/2	2A rg	29/6	30B gr	11/1	32A gr	1/5, 7/5, 41/4	32R jn	6/2, 9/6, 10/1	33C vi	37/1, 40/2
27B ba	20/2	2B rg	2/2, 2/5	30B jn	11/1	32A jn	2/3, 2/1	32V jn	29/4, 29/5	33D gr	25/1, 25/2, 25/3
27B mr	29/6	2C or	2/1	30B rg	11/1	32A nr	2/8	33 ba	1/2, 1/3, 2/6	33D gr	28/1
27C gr	44/1	2D ba	46/1	30C rg	40/2	32B ba	1/2, 5/1, 5/2	33 ba	2/9, 4/1, 6/2	33D mr	40/2
27J jn	21/1, 43/1	2R ba	2/1, 2/5, 2/1	31 gr	18/1, 18/2	32B ba	9/2, 10/1	33 ba	7/1, 7/2, 7/3	33E rg	21/1, 43/1
27M ba	21/1, 43/1	2R ba	2/1	31 gr	2/1	32B rg	1/2, 2/8, 5/1	33 ba	7/5, 8/1, 9/1	33J vi	43/1, 46/1
27R ba	44/1	3 ba	2/1	31A be	40/2	32B rg	5/2, 9/2, 10/1	33 ba	9/6, 10/1, 11/1	33M ba	40/2
27S jn	44/1	3 mr	2/3, 2/5	31A gr	18/1, 18/2	32B rg	20/2, 29/4, 39/2	33 ba	25/5, 32/1, 32/2	33M rg	25/2, 25/3
28 be	2/6	3 rg	2/7	31A mr	34/1	32C be	2/8	33 ba	38/1, 46/2	33M vi	34/1
28 or	18/1, 18/2	30 or	7/1	31A vi	34/1	32C jn	2/8, 3/6	33 rg	25/3	33P jn	25/3
28B or	18/1, 18/2	30 rg	7/1, 7/2, 7/3	32 ba	9/2, 46/1, 46/2	32C rg	7/1, 45/1	33 ve	46/1	33R ba	40/2
28R jn	34/1	30 rg	7/5	32 be	2/8	32D ba	2/8	33 vi	2/3, 2/1	33T ba	40/2
28R or	34/1	30 vi	7/1, 7/2, 7/3	32 gr	1/5, 41/4	32E mr	2/1	33A rg	25/3	33V ba	40/2
33V or	25/7	37A ba	16/1, 17/1, 44/1	40B ve	26/2	46 be	29/2, 29/3, 29/4	47A gr	11/1	5 rg	37/1, 39/1, 39/2
34 ba	40/2	37A vi	2/5	40C ve	25/1, 25/2, 25/3	46 be	29/5, 29/6, 39/3	47A rg	11/1	5 rg	39/3, 39/4
34 gr	22/1	37R jn	16/1	40C ve	25/7	46 be	39/4	47B jn	6/2, 7/1, 7/2	50 mr	16/1, 17/1
34C be	46/1	38 be	16/1, 44/1	40D ve	25/1, 25/2, 25/3	46 i ba	2/4	47B jn	7/3	51 be	16/1, 17/1
34R be	46/1	38 gr	2/3	40D ve	25/7	46A be	1/2, 2/3, 9/2	47B rs	6/2, 7/1, 7/2	52 mr	29/1, 29/2, 29/3
35 ba	40/2	38 jn	16/1, 17/1	40R ve	25/3	46A be	29/4, 39/1, 39/3	47B rs	7/3	52 mr	29/4, 29/5, 29/6
35 rg	2/1	38A be	16/1, 17/1, 44/1	40V ve	25/7	46A be	39/4	47J mr	41/4	520 jn	2/4
35 ve	46/1	39 jn	31/1	41 ba	2/5	46A mr	7/5	47M ve	10/1, 46/2	53 be	29/1, 29/2, 29/3
35 vi	28/1	39 rg	36/1	41 gr	2/3	46A vi	2/5	48 be	16/1, 17/1	53 be	29/4, 29/5, 29/6
36 gr	2/5	39A jn	31/1	42 ve	29/6	46B be	1/3, 2/3, 29/2	48 ve	2/5	53 rg	29/1, 29/2, 29/3
36 ve	28/1	3A rg	2/8	44 rg	2/4	46B be	29/3	49 ba	16/1, 17/1	53 rg	29/4, 29/5, 29/6
36A ve	28/1	4 ba	46/1	45 be	2/4, 29/2, 29/3	46C be	2/3	5 ba	45/1	53 vi	29/1, 29/2, 29/3
36B ba	28/1	4 be	2/3	45 be	29/4, 29/5, 29/6	46D ba	29/3	5 be	46/1	53 vi	29/4, 29/5, 29/6
36B ve	28/1	4 rg	2/6	45A be	29/2, 29/3, 29/6	47 ba	7/1, 7/2, 7/3	5 or	2/5	530 be	2/4
36C ve	28/1	40 ba	25/1, 25/2, 25/3	46 ba	29/4, 29/5, 29/6	47 jn	7/1	5 rg	1/2, 13/2, 13/3	55 ba	38/1
37 ba	2/5, 16/1, 44/1	40 gr	2/3	46 ba	39/1, 39/4	47 vi	7/2, 7/3	5 rg	14/1, 15/1, 15/2	55 mr	2/6
37 gr	2/3	40 jn	2/5	46 be	1/2, 1/3, 1/5	470 rg	2/5	5 rg	19/1, 19/2, 20/2	55 rg	37/1
37 jn	16/1, 17/1	40 rs	25/2, 25/3	46 be	2/3, 2/5, 7/5	47A be	11/1	5 rg	30/1, 30/2, 31/1	55 ve	13/2, 19/1, 30/2

NOMENCLATURES DES FILS

56
1

A JOUR LE: 01-09-90

NOM: MONTH

TEL: 4319

Numero Couleur	PAGES	Numero Couleur	PAGES	Numero Couleur	PAGES	Numero Couleur	PAGES	Numero Couleur	PAGES	Numero Couleur	PAGES
1 ba	2/8, 2/1, 46/1	108 rg	46/1	112B ve	2/7, 5/2	126B nr	3/7	14 jn	2/7	14R rg	46/1
10 gr	17/1	109 gr	46/1	112C ve	2/1, 2/1, 5/1	126C ba	3/3, 3/4, 3/5	14 rg	46/1	14R ve	19/2, 20/2
10 or	2/3	10A rg	25/5	112D jn	5/1	126C ba	3/7	14 ve	2/1, 19/1, 19/2	15 ba	29/4, 29/5
10 ve	2/4	10B mr	27/1, 27/2	112D ve	41/4	126R ba	3/3, 3/4, 3/5	14 vi	2/3	15 gr	28/1
101 rg	1/5	10C mr	27/3	112E ve	2/3	126R ba	3/7	140 ve	2/2	15 mr	2/6
101 ve	2/5	10D be	26/2	113 ba	44/1	126R be	3/6	140 vi	2/5	15 vi	2/3
101A ba	2/5	10E be	26/2	113 be	2/7	126V rg	3/6	141 be	2/3, 2/7	150 mr	30/1, 30/2
102 jn	18/2	10R mr	46/1	113A be	2/7	13 ba	2/7	141 rg	2/4	151 or	30/1, 30/2
104 rg	1/5, 39/2	111 gr	46/1	12 be	2/3	13 mr	2/6	141 ve	2/1	151 rg	30/1, 30/2
104A rg	39/2	111 mr	46/1	12 jn	2/4	135 ba	3/4, 3/5, 3/7	146 vi	41/4	151B jn	30/1, 30/2
106 rg	33/1	112 be	5/1, 5/2	12 or	46/1	137 vi	2/5	14A jn	46/1	157 be	3/6
107 bg	33/1	112 rg	41/4	12 rg	2/8	138 vi	2/5	14A ve	19/1, 19/2	157A be	3/6
107 be	33/1	112 ve	2/3, 2/7	120 or	2/5	139 rg	2/2	14B ve	19/1, 19/2, 20/2	15A ba	29/4, 29/5
107A ba	33/1	112A jn	2/2, 2/5	126 nr	3/3, 3/4, 3/5	139 vi	2/5	14B ve	30/1, 30/2	15A mr	2/6
107B bg	33/1	112A or	2/1	126 nr	3/7	13A rg	20/1, 20/2	14C ve	17/1	16 jn	25/1, 25/2, 25/3
107C bg	33/1	112A ve	5/1	126A ba	3/3, 3/4, 3/5	13B ba	24/1	14J rg	45/1	16 mr	46/1
108 be	46/1	112B gr	5/1	126A ba	3/7	13B be	44/1	14J ve	33/1	16 rg	25/1, 25/2, 25/3
		112B or	2/1	126B nr	3/3, 3/4, 3/5	13B rg	20/1	14M ve	30/1, 30/2	16 rg	27/3
161 or	2/5	1A jn	37/1	20 ba	2/3, 2/1	201C ve	25/3	211A be	24/1	240 rg	41/4
162 or	2/5	1A rg	2/4, 2/5, 2/7	20 mr	2/5	201D ve	27/3	211A rs	24/1	241 ve	41/4
16A be	27/3, 35/1	1A rg	2/8	200 be	27/1, 27/2, 27/3	203 rg	27/3	212 be	24/1	24A be	12/2
16A jn	25/1	1B rg	2/1	200 jn	27/1, 27/2, 27/3	204 ba	27/3	212A ba	24/1	24A mr	12/1, 44/1
16J rg	25/3	1C ba	12/2	200A be	27/1	204 gr	27/1, 27/2, 27/3	213 ba	24/1	25 jn	2/1
17 rg	2/8, 16/1, 44/1	1C gr	2/5	200A jn	27/1, 27/2, 27/3	205 be	27/3	213A rg	24/1	25 rg	46/1
171 or	2/5	1E ba	39/1, 39/2, 39/3	200B be	27/1	205 jn	27/3	214 ba	24/1	25 ve	19/1, 19/2, 38/1
172 or	2/5	1E ba	39/4	200B jn	27/3	206 bg	27/3	214A ve	24/1	25A ba	25/7
17A rg	44/1	1J rg	46/1, 46/1	200C be	27/1	20A be	2/1	22 ba	2/3	25A ve	19/2, 38/1
18 ba	2/3, 2/7	1M be	46/1, 46/1	200C jn	25/3	20A or	2/5, 3/5	22 be	46/1	25C ve	24/1
18 be	2/1	1R ba	2/1	200D jn	27/3	20B or	2/1	224 ve	44/1	25J ve	43/1, 46/1
18 gr	2/5	1R mr	2/3	201 ba	27/1, 27/2, 27/3	20C ba	2/1	226 vi	38/1	25R rg	46/1
18 mr	45/1	1R rg	2/4, 2/5, 2/8	201 ve	27/1, 27/2, 27/3	20D or	2/1	227 be	38/1	25R ve	19/1, 19/2
18A ba	2/3	1S gr	46/1	201A Ba	27/2	20E or	2/5	228 jn	38/1	25V ve	19/1
18B ba	2/3	2 be	2/7, 2/1	201A ba	27/1	21	1/2, 1/3	23 gr	12/1, 12/2	26 be	46/1, 45/2
19 ba	2/1	2 gr	2/1, 2/1	201A ve	27/1, 27/2, 27/3	21 ba	2/1, 46/1	23 mr	2/5, 2/7, 3/5	26 jn	2/1
19 be	46/1	2 rg	2/2, 2/3, 2/5	201B ba	27/1	211 ba	24/1	24 ba	2/1	26 ve	2/4
1A ba	2/1, 46/1	2 rg	2/1, 29/6	201B ve	27/3	211 jn	24/1	24 mr	12/1, 12/2, 44/1	26A jn	46/1

NOMENCLATURES DES FILS

56
4

A JOUR LE: 01-09-90

NCM: MOUTH

TEL: 4319

Numero Couleur	PAGES	Numero Couleur	PAGES	Numero Couleur	PAGES	Numero Couleur	PAGES	Numero Couleur	PAGES	Numero Couleur	PAGES
M20 vj	46/1	M3 vj	3/4, 3/5, 3/7	M34 vj	22/1	M47M vj	6/2, 7/2, 7/3	M58B vj	3/3, 3/4, 3/5	M87 vj	18/1, 18/2, 34/1
M21 vj	46/1	M3 vj	7/1, 11/1, 13/2	M37 vj	16/1, 17/1	M47M vj	10/1	M58B vj	3/7	M87 vj	37/1
M21A vj	46/1, 46/1	M3 vj	13/3, 14/1, 15/1	M37R vj	16/1	M49 vj	2/3	M6 vj	2/7, 2/1, 3/4	M89 vj	37/1
M21B vj	46/1	M3 vj	15/2, 16/1, 17/1	M38 vj	16/1, 17/1	M4A vj	14/1, 15/1, 15/2	M6 vj	3/5, 3/7, 8/1	M9 vj	2/7, 3/6, 26/1
M226 vj	38/1	M3 vj	20/1, 25/3, 26/1	M39 vj	31/1, 36/1	M4A vj	45/1	M6 vj	9/1, 9/2, 41/4	M9 vj	26/2, 27/1, 27/2
M227 vj	38/1	M3 vj	26/2, 32/1, 32/2	M39A vj	31/1	M4B vj	14/1, 15/1, 15/2	M6 vj	44/1	M9 vj	27/3, 33/1
M228 vj	38/1	M3 vj	44/1, 46/1	M4 vj	2/7, 2/1, 2/1	M4B vj	45/1	M65 vj	32/1, 32/2	M96 vj	2/3, 2/4, 2/7
M24 vj	2/4, 12/1, 12/2	M30 vj	40/2	M4 vj	25/3, 26/1, 26/2	M5 ba	2/1	M68 vj	15/2	M96 vj	2/1
M25 vj	2/7, 2/8, 19/1	M31 vj	40/2	M4 vj	44/1, 46/1	M5 vj	2/3, 2/7, 3/3	M69 vj	9/2	M98 vj	2/3, 2/5
M25 vj	19/2	M32 vj	1/5, 2/3, 5/1	M40 vj	25/1, 25/2, 25/3	M5 vj	3/4, 3/5, 3/7	M6A vj	43/1	MC vj	15/2
M27 vj	38/1, 46/1	M32 vj	5/2, 29/2, 29/3	M40 vj	27/3	M5 vj	18/1, 18/2, 46/1	M6M vj	3/5	MR vj	3/1, 3/2, 15/2
M27A vj	21/1, 38/1, 43/1	M32 vj	29/4, 29/5, 29/6	M45 vj	29/2, 29/3, 29/4	M53 vj	29/1, 29/2, 29/3	M6V vj	3/4, 3/7	MS1	2/2
M28 vj	46/1	M32 vj	38/1	M45 vj	29/5, 29/6	M53 vj	29/4, 29/5, 29/6	M7 vj	2/7, 2/1, 2/1	R ba	14/1, 39/1, 39/2
M29 vj	17/1	M33 vj	43/1, 46/1	M45A vj	29/2, 29/3, 29/6	M55 vj	13/2, 13/3, 37/1	M74 vj	9/6	R ba	39/3, 39/4
M29B vj	24/1	M33B vj	19/1, 19/2	M45B vj	29/6	M55M vj	39/1, 39/2, 39/3	M76 vj	2/3, 2/5, 2/7	R jn	3/3
M3 vj	1/5, 2/1, 2/2	M33D vj	40/2	M46 vj	9/2	M55M vj	39/4	M76 vj	2/1, 7/5	R ve	3/6
M3 vj	2/5, 2/7, 2/8	M33V vj	40/2	M47B vj	6/2, 7/1, 7/2	M56 vj	13/2	M79 vj	46/1, 46/1	R1	14/1
M3 vj	2/1, 2/1, 3/3	M33v	43/1	M47B vj	7/3	M57 vj	3/1, 3/2, 3/6	M8 vj	2/7	R1 mr	45/1
R2 vi	45/1										
RA mr	14/1, 39/1, 39/2										
RA mr	39/3, 39/4, 45/1										
RB mr	14/1, 39/1, 39/2										
RB mr	39/3, 39/4, 45/1										
RC ve	39/1, 39/2, 39/3										

NOMENCLATURES DES FILS

56
3

A JOUR LE: 01-09-90

NOM: MOUTH

TEL: 4319

Numero Couleur	PAGES	Numero Couleur	PAGES	Numero Couleur	PAGES	Numero Couleur	PAGES	Numero Couleur	PAGES	Numero Couleur	PAGES
55 ve	37/1, 39/1, 39/2	55B rg	44/1	58 be	3/1, 3/2, 3/6	61 vi	18/1, 18/2	6B ve	43/1	74 jn	2/6
55 ve	39/3, 39/4, 45/1	55E mr	39/1, 39/2, 39/3	58A ba	3/2, 3/6	61A vi	18/2	6C bg	2/8, 3/7	74 rg	2/6, 2/9, 9/6
55 vi	13/2, 13/3, 19/2	55E mr	39/4	58A ve	3/3, 3/4, 3/5	62 mr	18/1, 18/2	6C jn	3/4, 3/5, 3/7	74A ba	2/9
55 vi	20/2, 30/1, 31/1	55R rg	39/1, 39/2, 39/3	58A ve	3/7	63 rs	13/2, 13/3	6J ba	3/5	74A rg	2/6
55 vi	37/1, 38/1, 39/1	55R rg	39/4	58B ba	3/2, 3/6	64 jn	13/2, 13/3, 31/1	6J mr	43/1	75 jn	4/1
55 vi	39/2, 39/3, 39/4	55R ve	13/2, 13/3	58B ve	3/3, 3/4, 3/5	65 be	32/1, 32/2	6M rs	2/8	75A jn	4/1
55A jn	46/1, 46/1	56 ve	13/2, 39/1, 39/2	58B ve	3/7	65A ba	32/1, 32/2	6M vi	3/5	76 ba	2/3, 2/5, 2/7
55A or	13/3, 19/2, 20/2	56 ve	39/3, 39/4	58C ba	3/3	68 be	38/1	6R jn	3/4, 3/5, 3/7	76 ba	2/8, 2/1, 7/5
55A or	30/1, 31/1, 37/1	57 rg	3/3, 3/4, 3/5	58C be	3/2	68 gr	15/2, 44/1	6R ve	43/1	76 vi	7/5
55A or	39/1, 39/2, 39/3	57 rg	3/7	58J ba	3/2	68A rg	38/1	6V or	3/4, 3/5, 3/7	76A jn	2/3, 2/5, 2/7
55A or	39/4, 45/1	57 ve	3/1, 3/2, 3/3	58J ve	3/3	69 jn	8/1, 9/1	7 ba	2/4	76A jn	2/1, 7/5
55A rg	37/1, 44/1	57 ve	3/4, 3/5, 3/6	58M be	3/3, 3/4, 3/5	69 ve	9/2	7 jn	2/3	79 ba	46/1, 46/1
55A vi	13/3, 19/2, 20/2	57 ve	3/7	58M be	3/7	69A ve	8/1, 9/1, 9/2	7 rg	2/1	79 rg	46/1
55A vi	30/1, 31/1, 37/1	57B rg	3/3	58R ve	3/4, 3/5, 3/7	69B nr	8/1, 9/1	7 ve	2/7	79B rg	46/1
55B jn	46/1	57B ve	3/2	5B ve	2/1	69C nr	8/1, 9/1	70 ve	8/1, 9/1, 9/2	7A gr	1/2
55B mr	39/1, 39/2, 39/3	57R ve	3/4, 3/5, 3/7	6 be	2/7	6A vi	3/4, 3/5, 3/7	72 or	17/1	7A mr	1/3
55B mr	39/4	58 ba	3/3, 3/4, 3/5	6 jn	43/1	6A vi	43/1, 46/1	73 rg	1/5	7A rs	1/2, 1/3
55B or	20/2	58 ba	3/7	6 mr	2/1	6B jn	3/5	74 ba	2/8, 2/9	7A ve	1/3
8 ba	46/1	92A vi	26/1, 26/2	BL1	2/8	M vj	3/7, 25/3, 27/1	M1 vj	29/3, 29/4, 29/5	M14A vj	19/1
8 gr	2/3	92B vi	26/1, 26/2	BL1 ba	41/4	M vj	27/2, 27/3, 37/1	M1 vj	29/6, 30/1, 30/2	M150 vj	30/1, 30/2
8 jn	2/7	92C nr	26/2	BL2	2/3, 2/5, 2/7	M vj	44/1, 46/1	M1 vj	31/1, 32/1, 32/2	M151 vj	30/1, 30/2
81 ve	46/1, 46/1, 46/1	94 gr	26/1, 26/2	BL3	2/3	M1 vj	1/5, 2/1, 2/2	M1 vj	33/1, 38/1, 40/2	M157 vj	3/6
81 vi	46/1	94A gr	26/1, 26/2	CC1 gr	41/4	M1 vj	2/3, 2/4, 2/5	M1 vj	43/1, 46/1, 46/1	M16 vj	2/1
81A mr	46/1	95 gr	26/1, 26/2	CC2 gr	41/4	M1 vj	2/7, 2/1, 3/3	M1 vj	46/1, 46/1	M16J vj	25/3
81A ve	46/1	96 or	2/3, 2/4, 2/7	CC32 gr	41/4	M1 vj	3/4, 3/5, 3/7	M10 vj	2/7, 12/2, 26/1	M17 vj	2/1
83 ve	46/1	96 or	2/1, 26/1, 26/2	IB mr	2/5	M1 vj	6/2, 7/1, 7/2	M10 vj	26/2, 27/1, 27/2	M18 vj	2/3
84 mr	2/1	96A or	2/3, 2/4, 2/7	J be	15/1, 15/2, 44/1	M1 vj	7/3, 8/1, 9/1	M10 vj	27/3, 33/1	M19 vj	2/4, 2/5
87 ba	18/1, 18/2, 37/1	96A or	2/1, 26/1, 26/2	J1 be	45/1	M1 vj	9/2, 9/6, 10/1	M106 vj	33/1	M2 vj	1/5, 2/1, 2/2
87A ba	37/1	97 mr	26/1, 26/2	J1 rs	15/1, 15/2	M1 vj	11/1, 12/2, 13/2	M107 vj	33/1	M2 vj	2/3, 2/4, 2/5
87M jn	34/1	98 be	2/3, 2/5	JA gr	15/1, 15/2	M1 vj	13/3, 14/1, 15/1	M10A vj	25/5	M2 vj	2/8, 2/1, 2/1
89 be	37/1	B112 bl	41/4	JB gr	15/1, 15/2, 45/1	M1 vj	15/2, 16/1, 17/1	M10B vj	25/5	M2 vj	7/1, 7/2, 7/3
9 ba	2/3	B141	2/1	JC mr	15/2	M1 vj	18/1, 18/2, 19/1	M10C vj	27/3	M2 vj	13/2, 13/3, 16/1
9 be	2/8	B2 rg	3/6	JR mr	15/2	M1 vj	19/2, 20/1, 21/1	M12 vj	2/1	M2 vj	17/1, 26/1, 26/2
9 ve	2/1, 46/1	B27	2/1	M vj	2/5	M1 vj	25/1, 25/2, 25/3	M13 vj	2/3, 2/1, 20/2	M2 vj	27/3, 28/1, 39/1
92 ba	26/1, 26/2	B31	2/1	M vj	2/2, 2/7, 2/1	M1 vj	26/1, 26/2, 27/3	M14 vj	2/4	M2 vj	39/2, 39/3, 39/4
92 vi	26/1, 26/2	BL1	2/3, 2/4, 2/7	M vj	3/3, 3/4, 3/5	M1 vj	28/1, 29/1, 29/2	M141 vj	2/1	M2 vj	44/1, 46/1, 46/1