

CARROSSERIE MULHOUSE

UMC/METHODES CENTRALES

SCHEMA ELECTRIQUE

205

(TOUS MODELES)

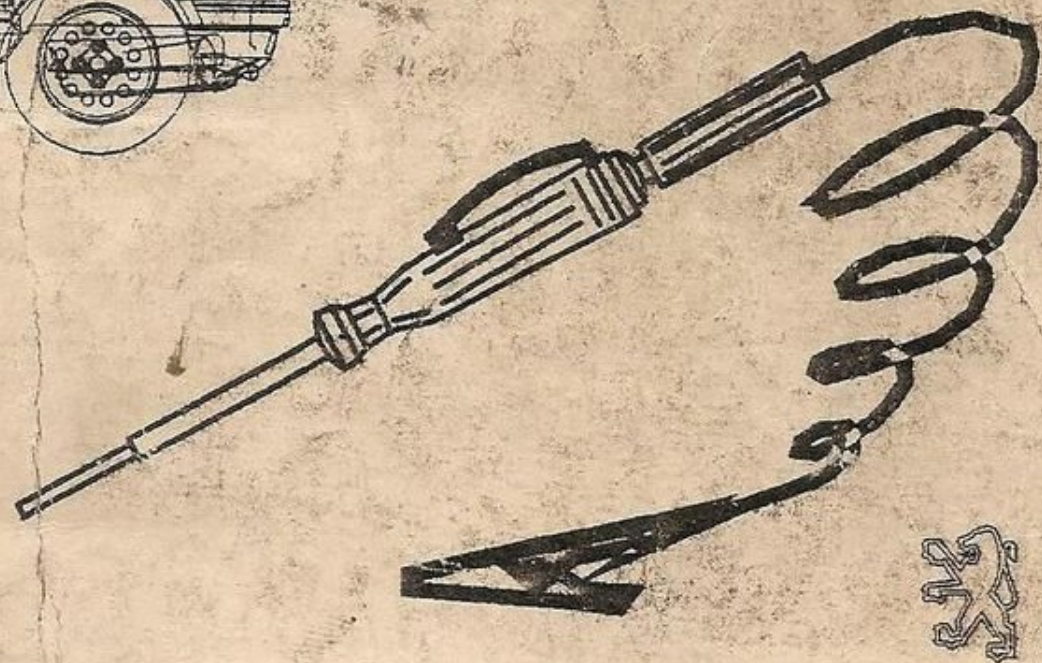
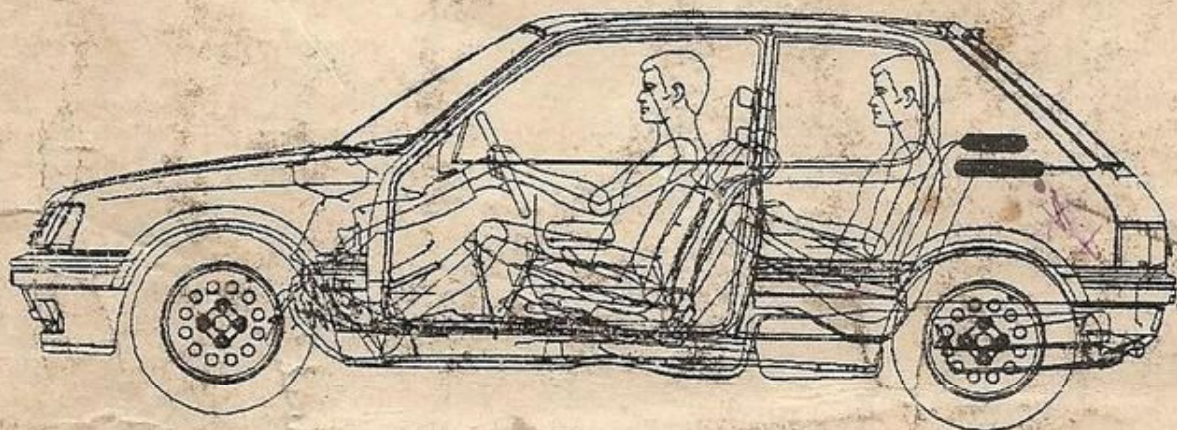

Document realise en CFAO
le 20-06-85
par VIGNES Tel : 3162



REPERTOIRE

A JOUR LE: 20-06-85

NOM: VIGNES

TEL: 3162

FONCTIONS	TYPES	PAGES	FONCTIONS	TYPES	PAGES
DEMARREUR ALTERNATEUR	ESS	1/1	TEMOIN FREIN A MAIN,NIVEAU LIQUIDE DE FREINS	GTI	27/2
DEMARREUR ALTERNATEUR	DSL	1/2	ALIM.AUTO RADIO , HAUT PARLEURS		28/1
DEMARREUR ALTERNATEUR	GTI	1/3	PLAFONNIER , LECTEUR DE CARTES		29/1
ALLUMAGE BRANCHEMENT BOBINE		2/1	LEVE VITRES ELECTRIQUES		30/1
ELECTROVANNE TEM+BOUGIES PRECHAUFF.		2/2	CONDAMNATION CENTRALISEE	ESS	31/1
INJECTION ELECTRONIQUE		2/3	CONDAMNATION CENTRALISEE	GTI	31/2
MOTOVENTILATEUR 1 VITESSE		3/1	FEUX STOP		32/1
MOTOVENTILATEUR 2 VITESSES		3/2	FEUX DE REcul		33/1
GROUPE MOTOVENTILATEURS		3/3	FEU ARRIERE BROUILLARD		34/1
GROUPE MOTOVENTILATEURS REFRI		3/4	ECLAIREURS PLAQUE POLICE		35/1
TEMOIN STARTER		4/1	JAUGE CARBURANT	ESS	36/1
COMPTE TOURS	ESS	5/1	JAUGE CARBURANT	GTI	36/2
COMPTE TOURS	GTI	5/2	LUNETTE CHAUFFANTE		37/1
TEMOINS STOP,PRESSION HUILE,TEMPERATURE EAU,NIVEAU EAU	ESS	6/1	ESSUIE VITRE ARRIERE		38/1
TEMOINS COMBINE	GTI	7/1	ALIMENTATION ATTACHE REMORQUE		39/1
TEMOIN USURE PLAQUETTES,NIVEAU LIQUIDE FREIN	ESS	8/1	ECLAIREUR DE COFFRE		39/2
TEMOIN USURE PLAQUETTES	GTI	9/1	LAVE PROJECTEURS		40/1
DETECTEUR PRESENCE EAU DANS GASOIL		10/1	SIEGES CHAUFFANTS		41/1
TEMOIN TEMPERATURE HUILE	DSL	12/1	FEUX DIURNES		42/1
RECEPTEURS COMBINE	GTI	13/1	FEUX DIURNES	DSL	42/2
RECEPTEUR TEMPERATURE EAU (GLD FINLANDE)		13/2	PARTICULARITE REFRIGERATION	ESS	43/1
AVERTISSEUR	ESS	14/1	PARTICULARITE REFRIGERATION	DSL	43/2
AVERTISSEUR	GTI	14/2	SURETE NATIONALE GHI 032		43/3
FEUX DE POSITION	ESS	15/1	SURETE NATIONALE GHI 036		43/4
FEUX DE POSITION	GTI	15/2	AUTO ECOLE-ORDINATEUR DE BORD,DOUBLES COMMANDES		43/5
FEUX DE CROISEMENT	ESS	16/1	FONCTIONS PROTEGEES PAR UN FUSIBLE		44/1
FEUX DE CROISEMENT	GTI	16/2	BOITIER INTERCONNEXIONS		44/2
FEUX DE ROUTE	ESS	17/1	CONNECTEURS SUR BOITIER INTERCONNEXIONS		45/1
FEUX DE ROUTE-LONGUE PORTEE	GTI	17/2	CONNECTEURS SUR BOITIER INTERCONNEXIONS	GTI	45/2
FEUX ANTIBROUILLARD AVANT		17/3	CONNECTEURS SUR COMBINE	ESS	45/3
CLIGNOTANTS REPETITEURS	ESS	18/1	CONNECTEURS SUR COMBINE	GTI	45/4
CLIGNOTANTS REPETITEURS	GTI	18/2	CONNECTEURS + INTERCONNEXIONS		45/5
SIGNAL DANGER	ESS	19/1	IMPLANTATION CONNECTEURS		46/1
SIGNAL DANGER	GTI	19/2	IMPLANTATION CONNECTEURS		46/2
ESSUIE VITRE AV NON TEMPORISE		20/1	NUMEROTATION APPAREILS + ABREVIATIONS		47/1
ESSUIE VITRE AV TEMPORISE		21/1	NOMENCLATURE FILS		48/1
ECLAIRAGE FAC.CLIM.,ALL.CIG.,COMBINE	ESS	22/1	NOMENCLATURE FILS		48/2
ECLAIRAGE FAC.CLIM.,ALL.CIG.,COMBINE	GTI	22/2			
MONTRE AIGUILLE		23/1			
MONTRE DIGITALE,ECLAIR. VIDE POCHE		24/1			
CLIMATISEUR		25/1			
ALLUME CIGARE		26/1			
TEMOIN FREIN A MAIN	ESS	27/1			

TYPE CONCERNE:
-205ESS

DEMARREUR ALTERN. TEMOIN DE CHARGE

A JOUR LE: 20-06-85

NOM: VIGNES

TEL: 3162

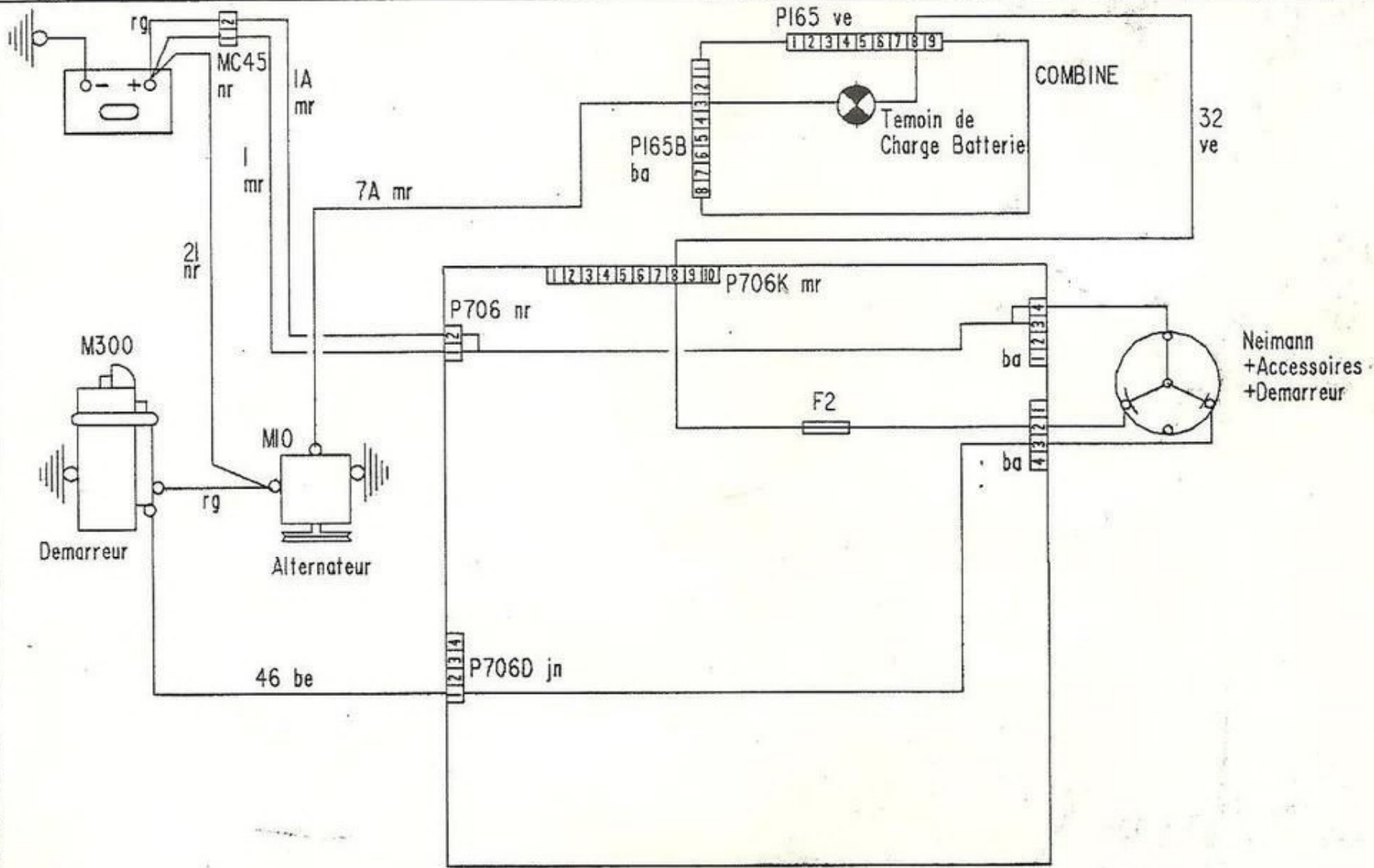

TYPE CONCERNE:
-205DSL

DEMARREUR ALTERNAT. TEMOIN DE CHARGE

2

A JOUR LE: 20-06-85

NOM: VIGNES

TEL: 3162

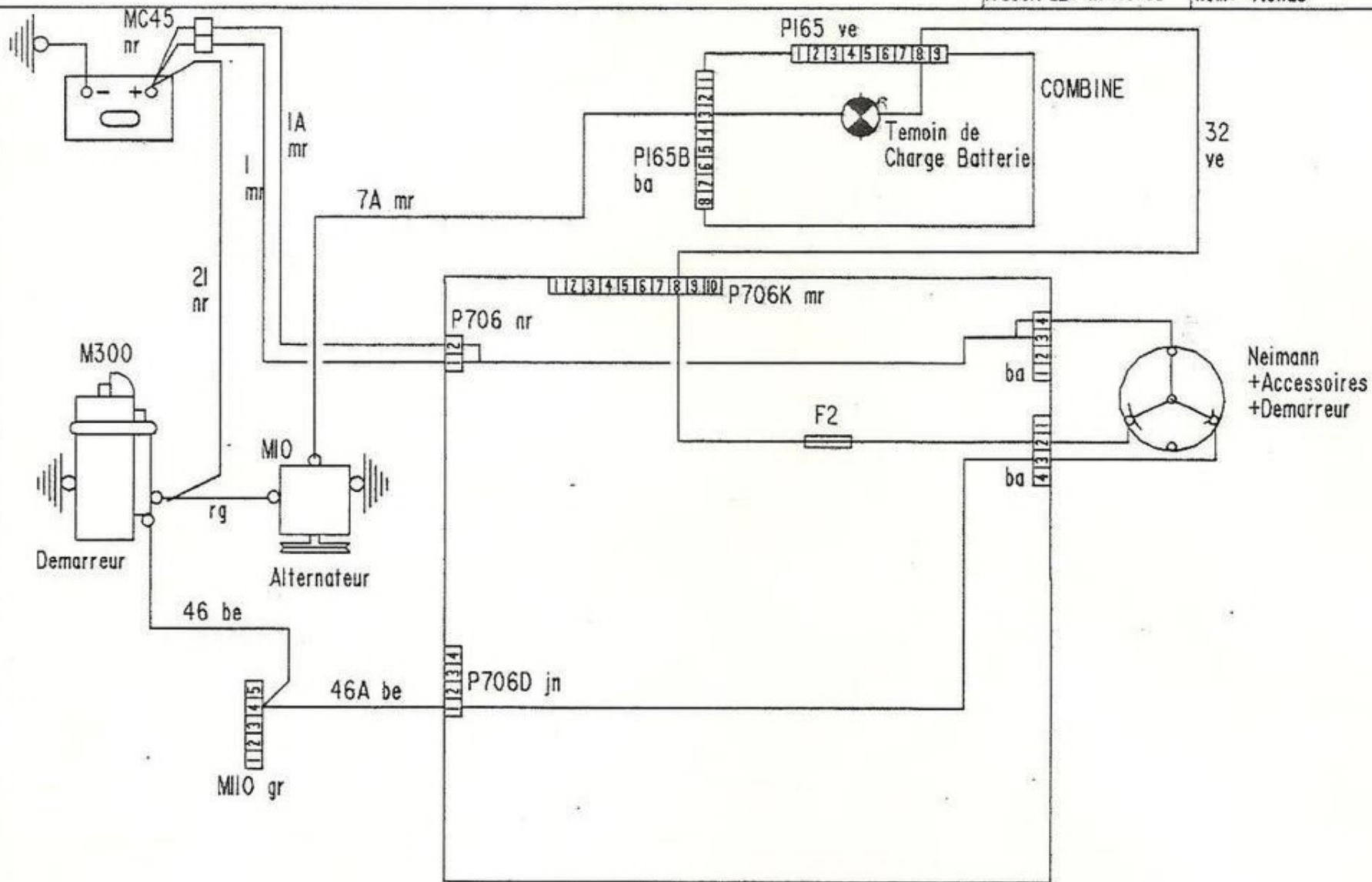

TYPE CONCERNE
-205GT1

DEMARREUR ALTERNAT. TEMOIN DE CHARGE

3

A JOUR LE: 20-06-85

NOM: VIGNES

TEL: 3162

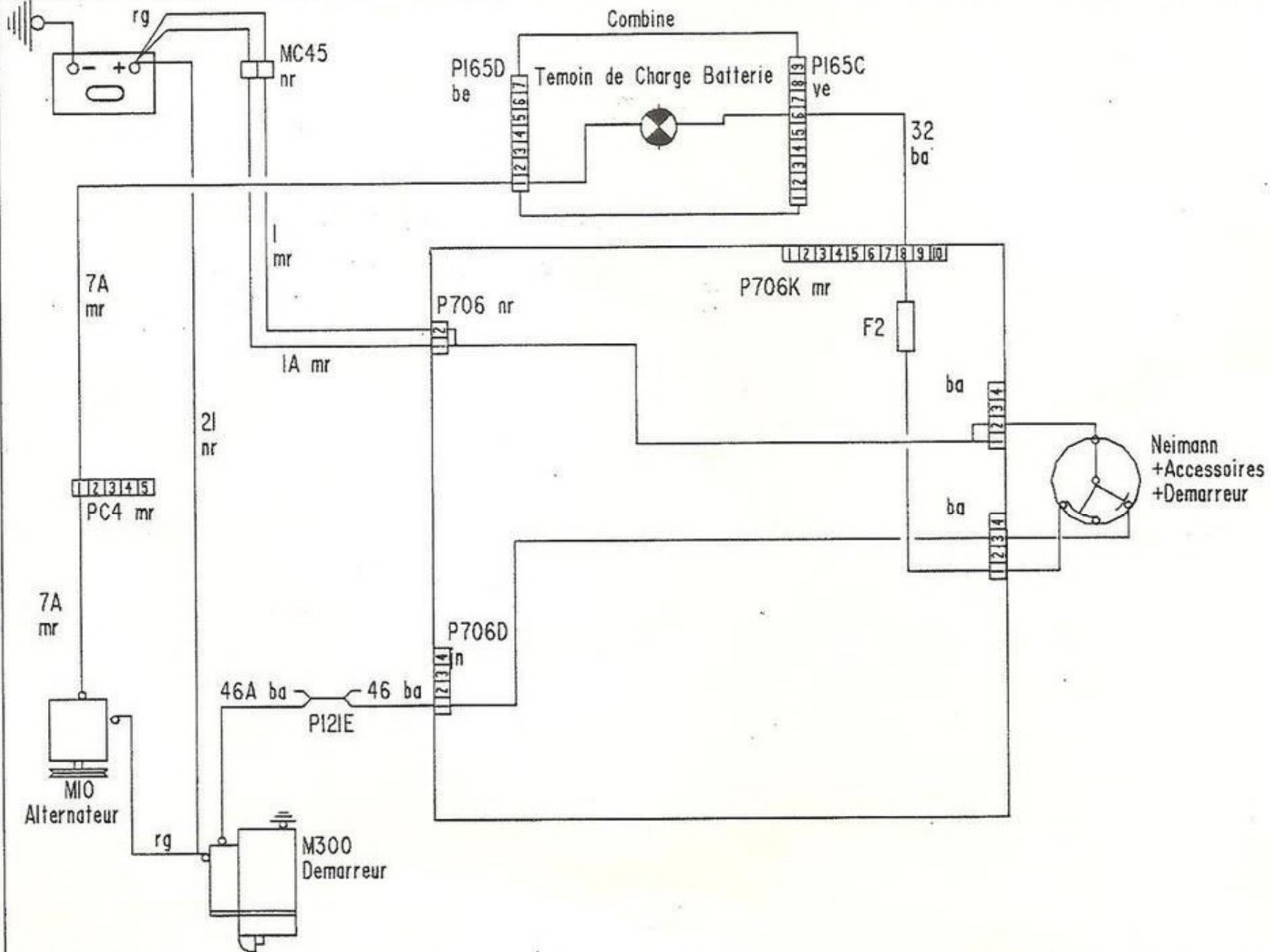

BOITIER DECELERATION (ANTIPOLLUTION):
 UNIQUEMENT EN SUISSE-SUEDE AVEC:
 -1 ELECTROVANNE SUR MOTEUR XW7
 -2 ELECTROVANNES SUR MOTEUR XY6B

TYPES CONCERNES:
 -205ESS
 -205GTI

ALLUMAGE
 BRANCHEMENT BOBINE

2
 1

A JOUR LE: 20-06-85

NOM: VIGNES

TEL: 3162

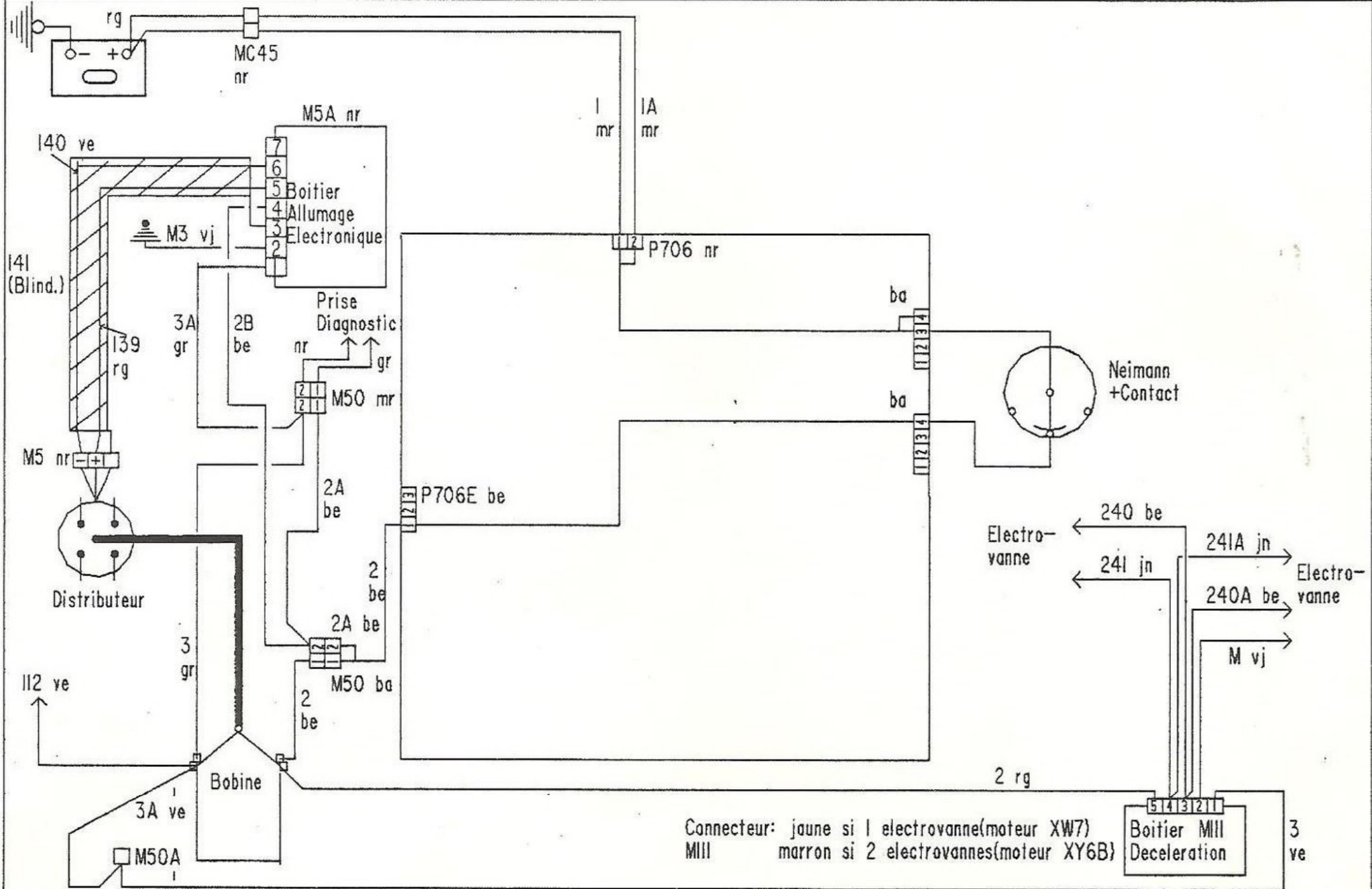

TYPE CONCERNE:
-205DSL

ELECTROVANNE
TEM.+BOUGIES PRECHA.
2/2

A JOUR LE: 20-06-85

NOM: VIGNES

TEL: 3162

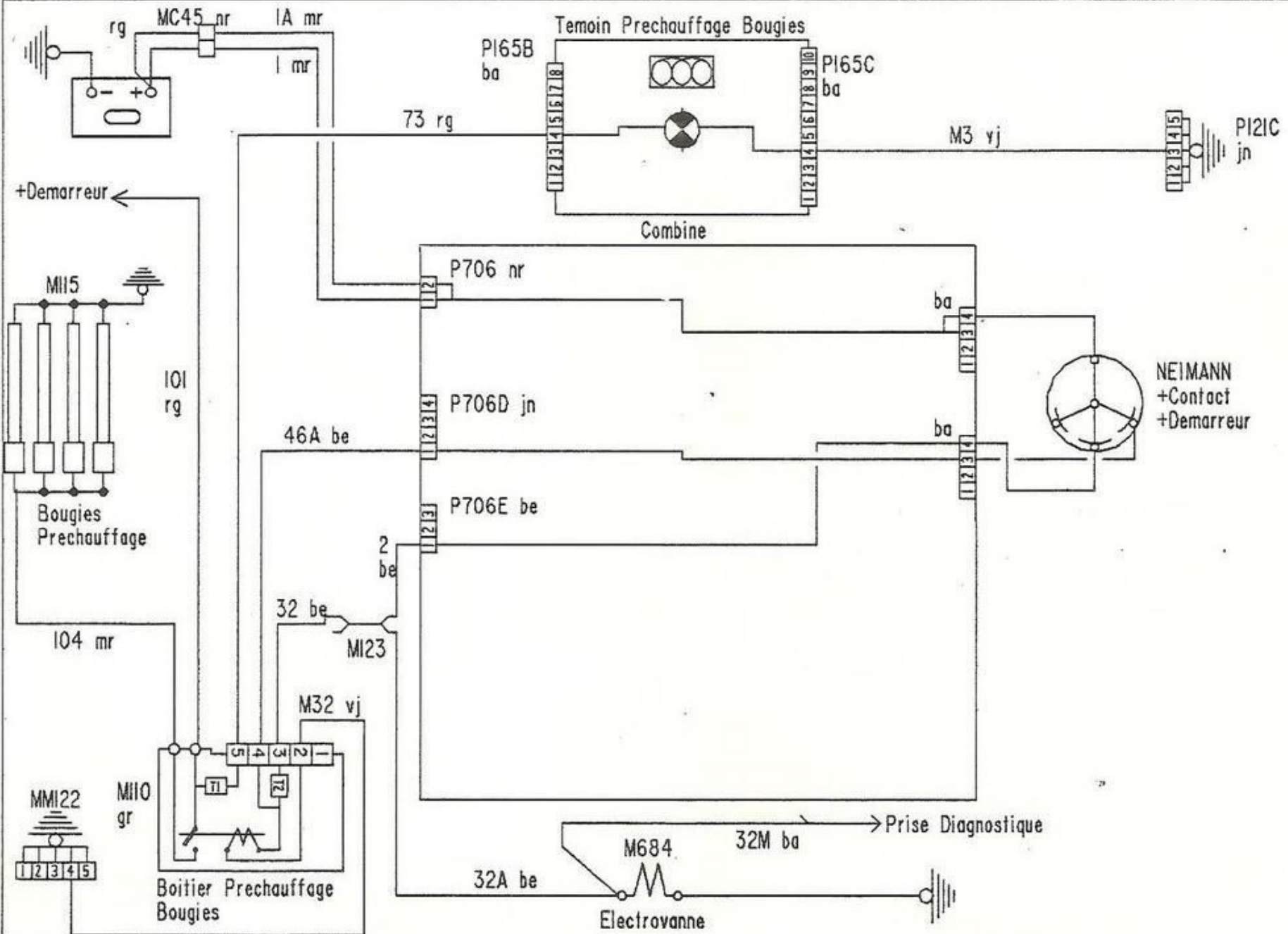

E1 E2 E3 SONT DES EPISSURES SE TROUVANT
A L'INTERIEUR DU FAISCEAU

TYPE CONCERNE:
-205GT1

INJECTION ELECTRONIQUE

2
3

A JOUR LE: 20-06-85

NOM: VIGNES

TEL: 3162

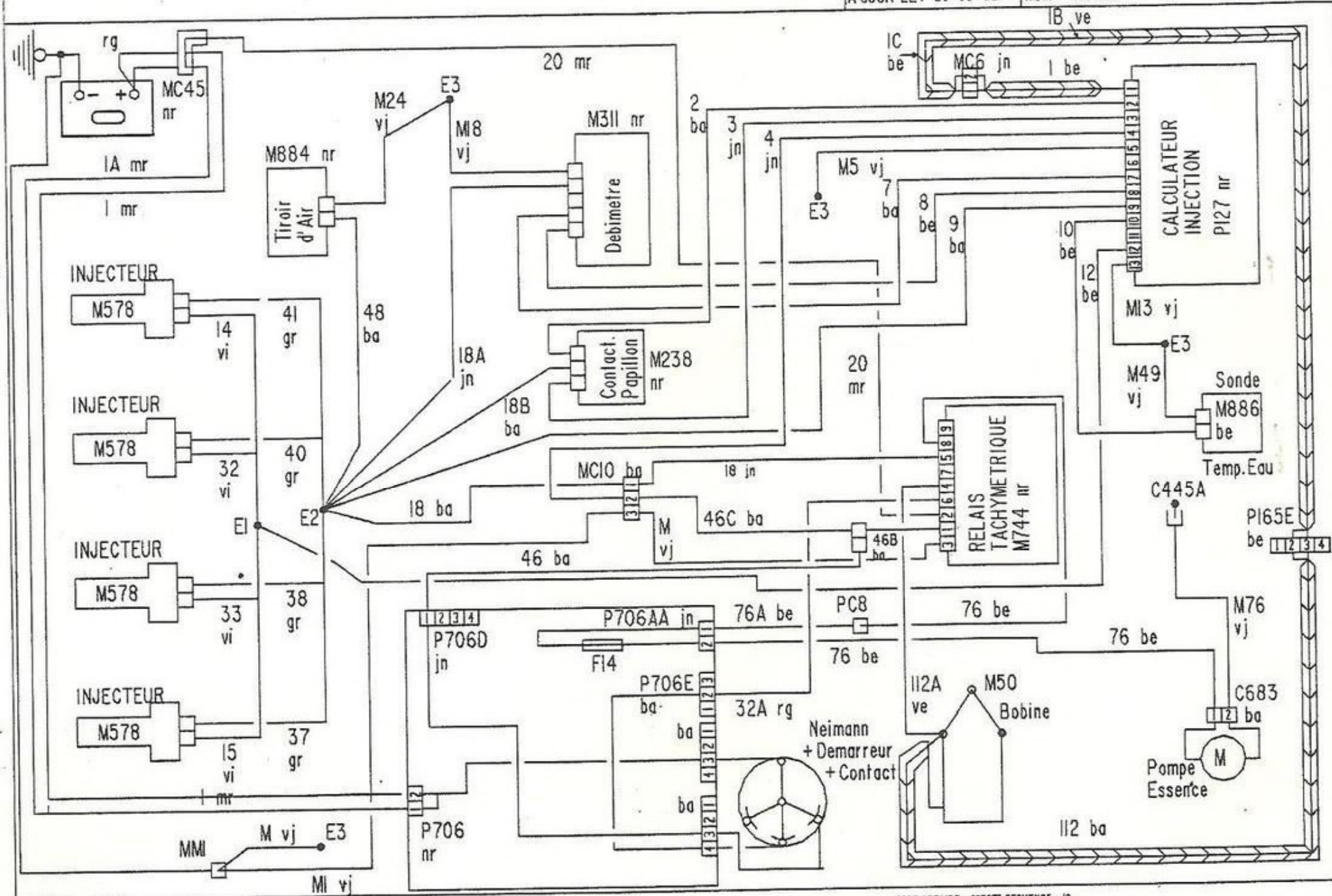

TYPE CONCERNE:
-205ESS

MOTOVENTILATEUR
1 VITESSE

3
1

A JOUR LE: 20-06-85

NOM: VIGNES

TEL: 3162

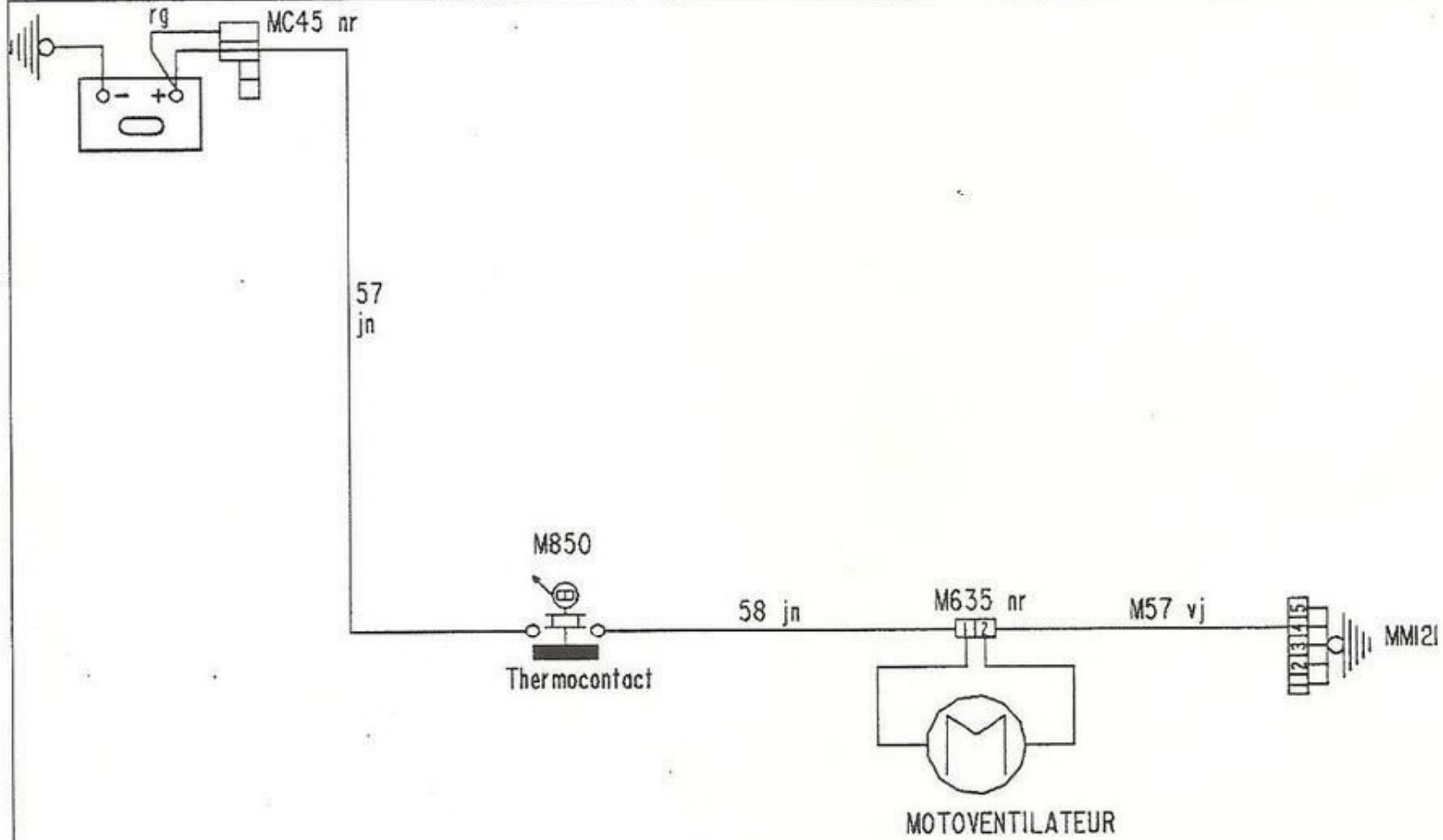

B ENCLENCHE: PETITE VITESSE
B+H ENCLENCHES: GRANDE VITESSE

TYPES CONCERNES:
-205ESS
-205GTI

MOTOVENTILATEUR
2 VITESSES

3
2

A JOUR LE: 20-06-85

NOM: VIGNES

TEL: 3162

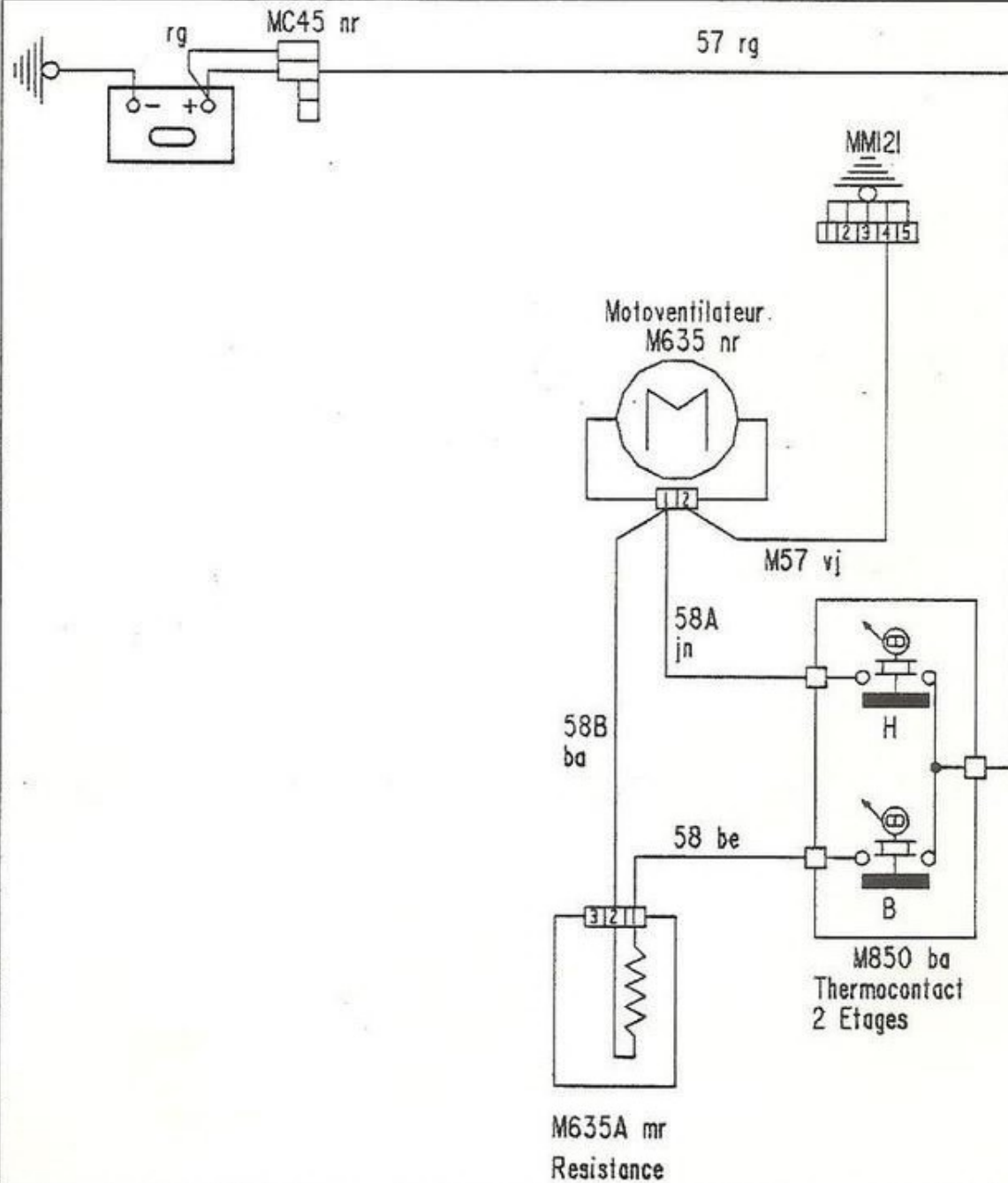

Thermocontact M850:
 -B enclenche: V1 V2 en serie
 -B+H enclenches: V1 V2 en parallele

TYPE CONCERNE:
 -205DSL

GRUPE
 MOTOVENTILATEURS

3
 3

A JOUR LE: 20-06-85

NOM: VIGNES

TEL: 3162

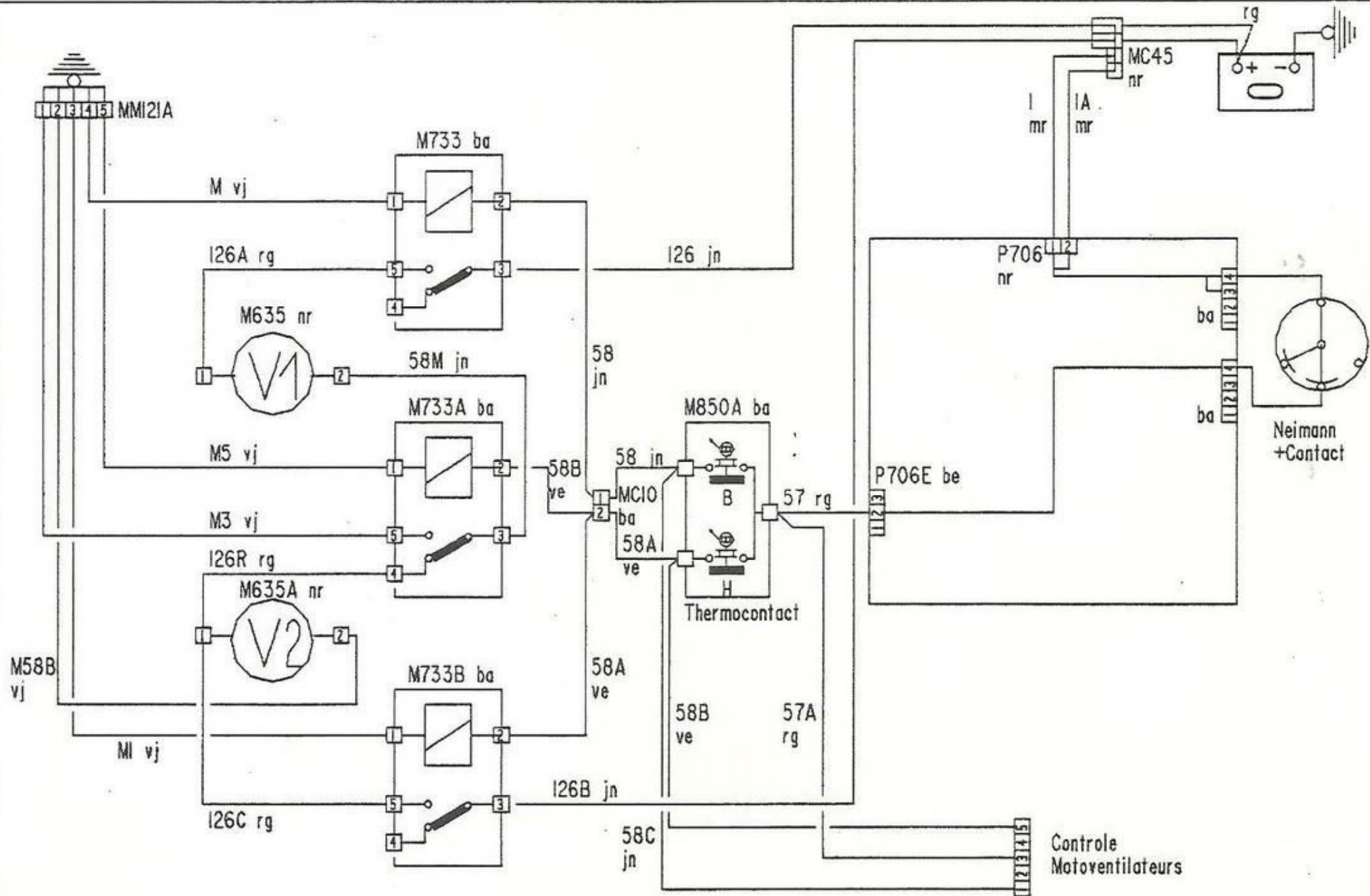

Thermocontact M850:
 -B enclenche: V1 V2 en serie
 -B+H enclenches: V1 V2 en parallele

TYPE CONCERNE:
 -205REFRI

GRUPE
 MOTOVENTILATEURS

3
 4

A JOUR LE: 20-06-85

NOM: VIGNES

TEL: 3162

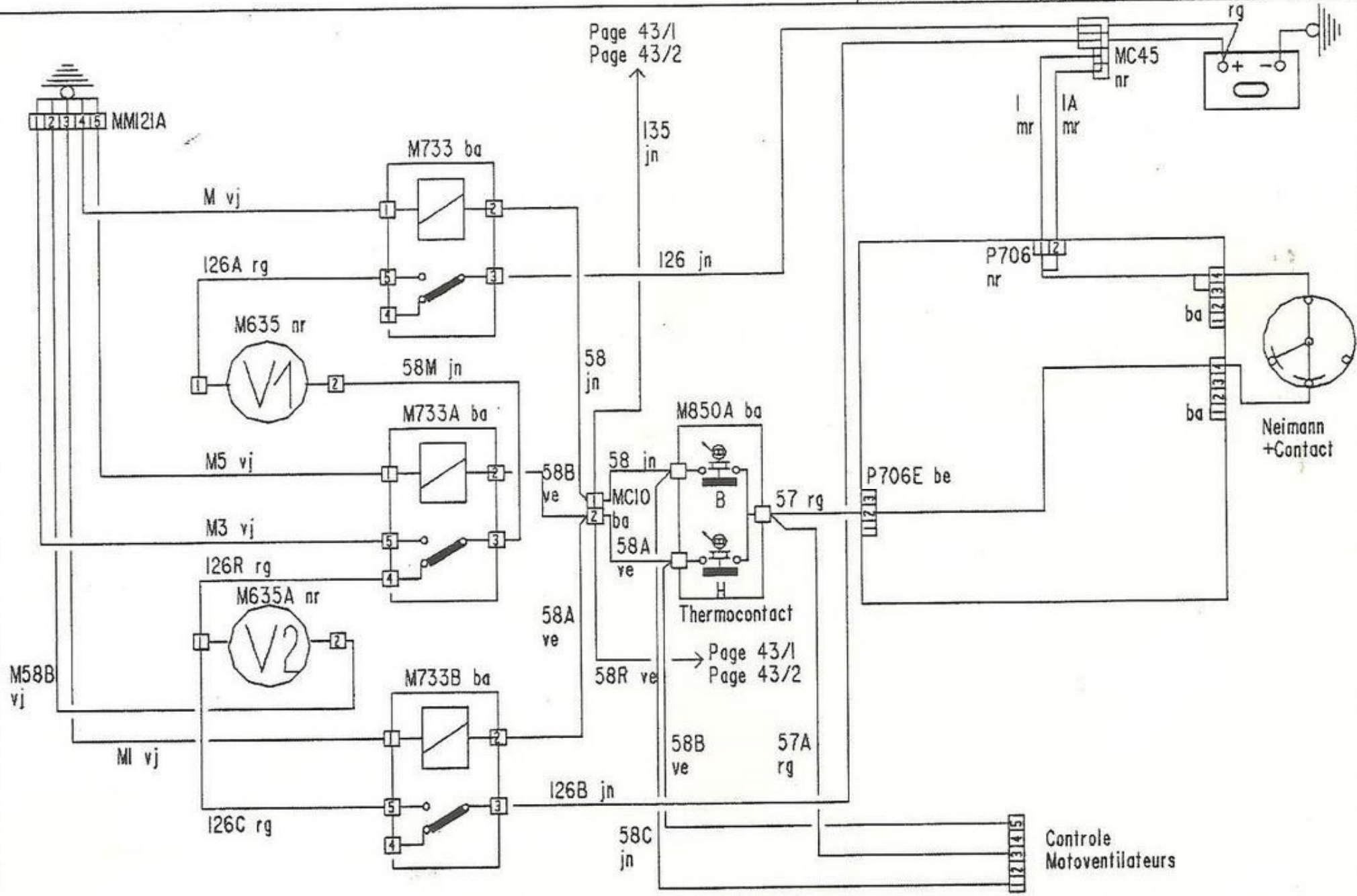

TYPE CONCERNE:
-205ESS

TEMOIN STARTER

4
1

A JOUR LE: 20-06-85

NOM: VIGNES

TEL: 3162

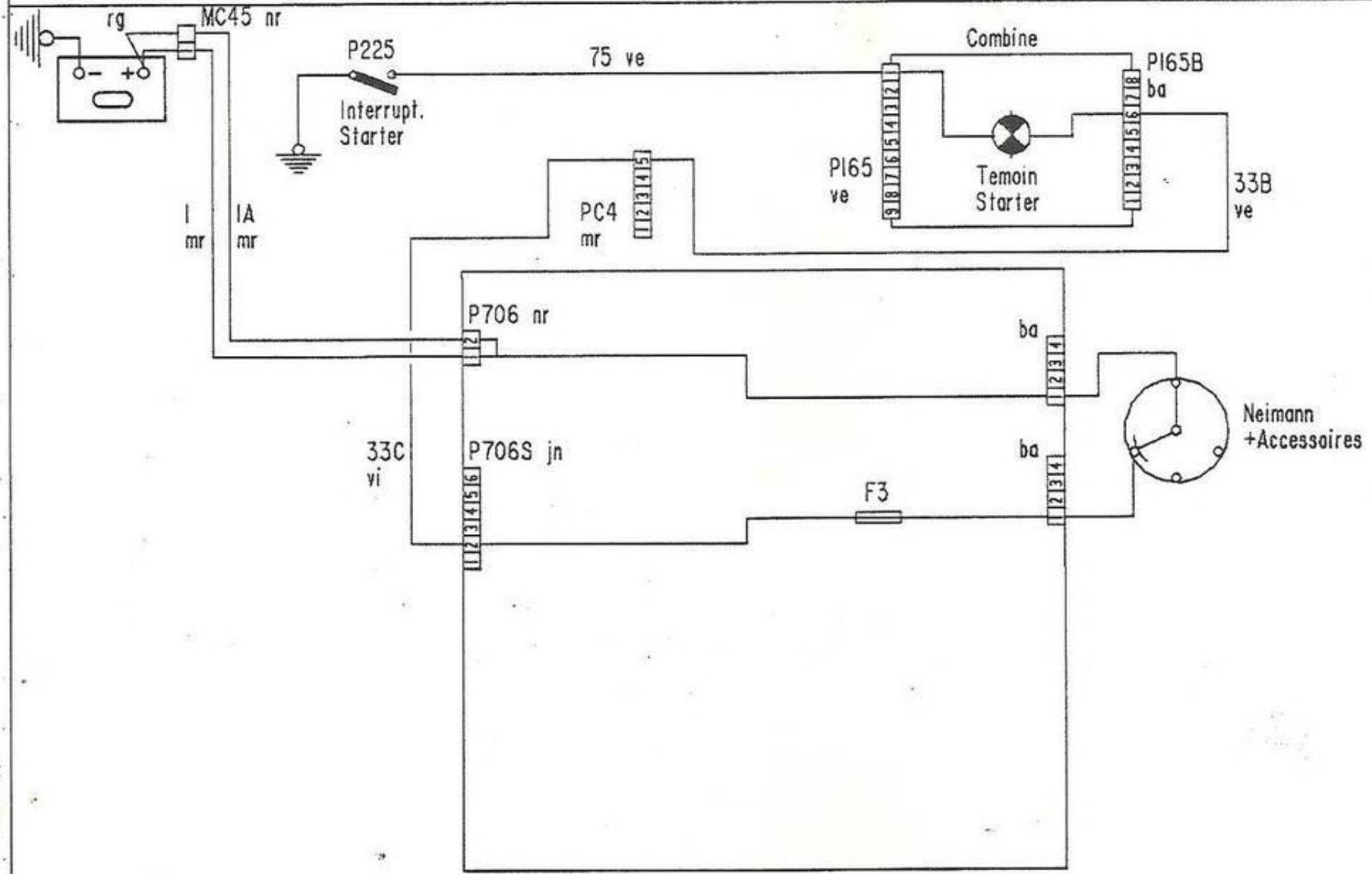

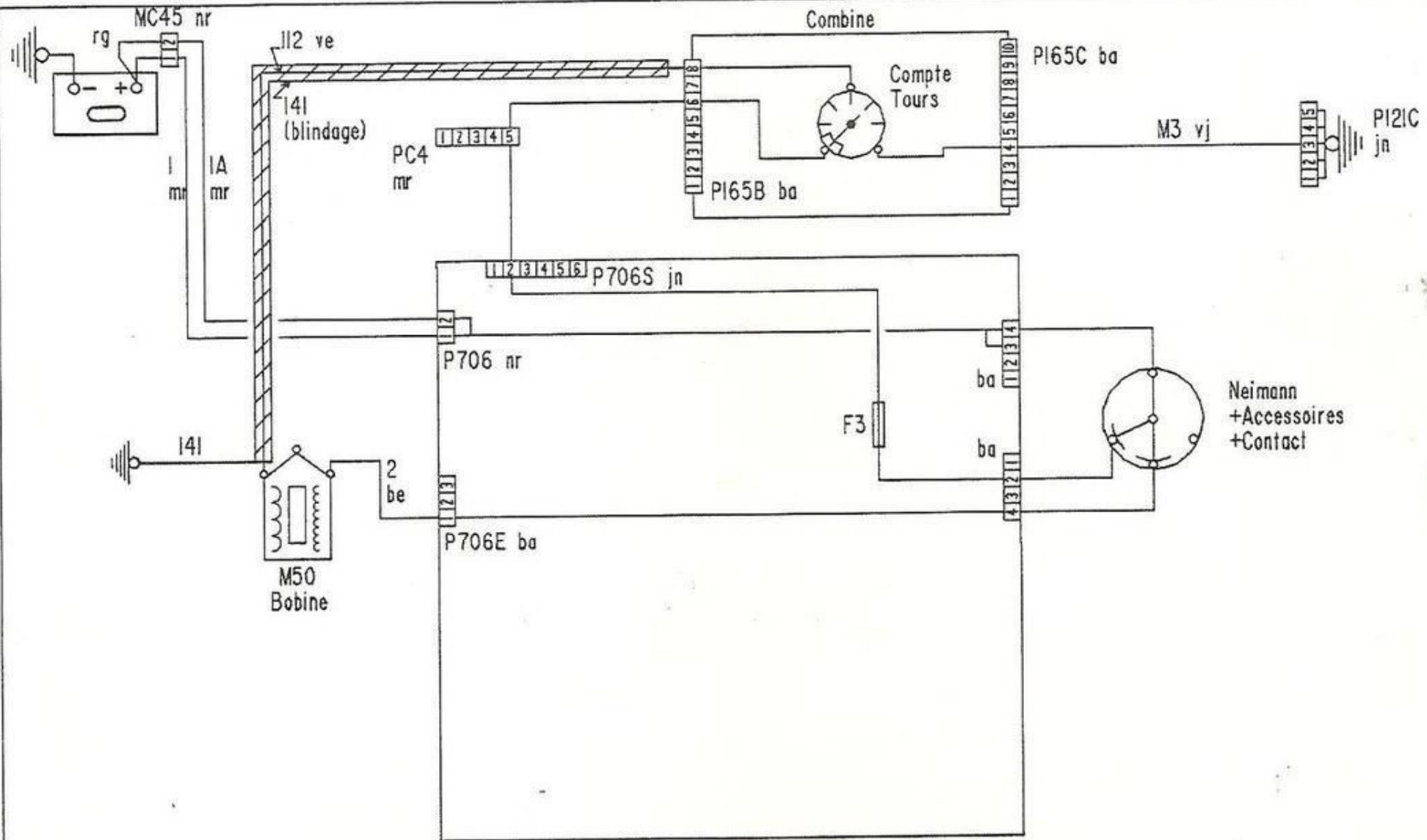

TYPE CONCERNE:
-205GT1

COMPTE TOURS

5
2

A JOUR LE: 20-06-85

NOM: VIGNES

TEL: 3162

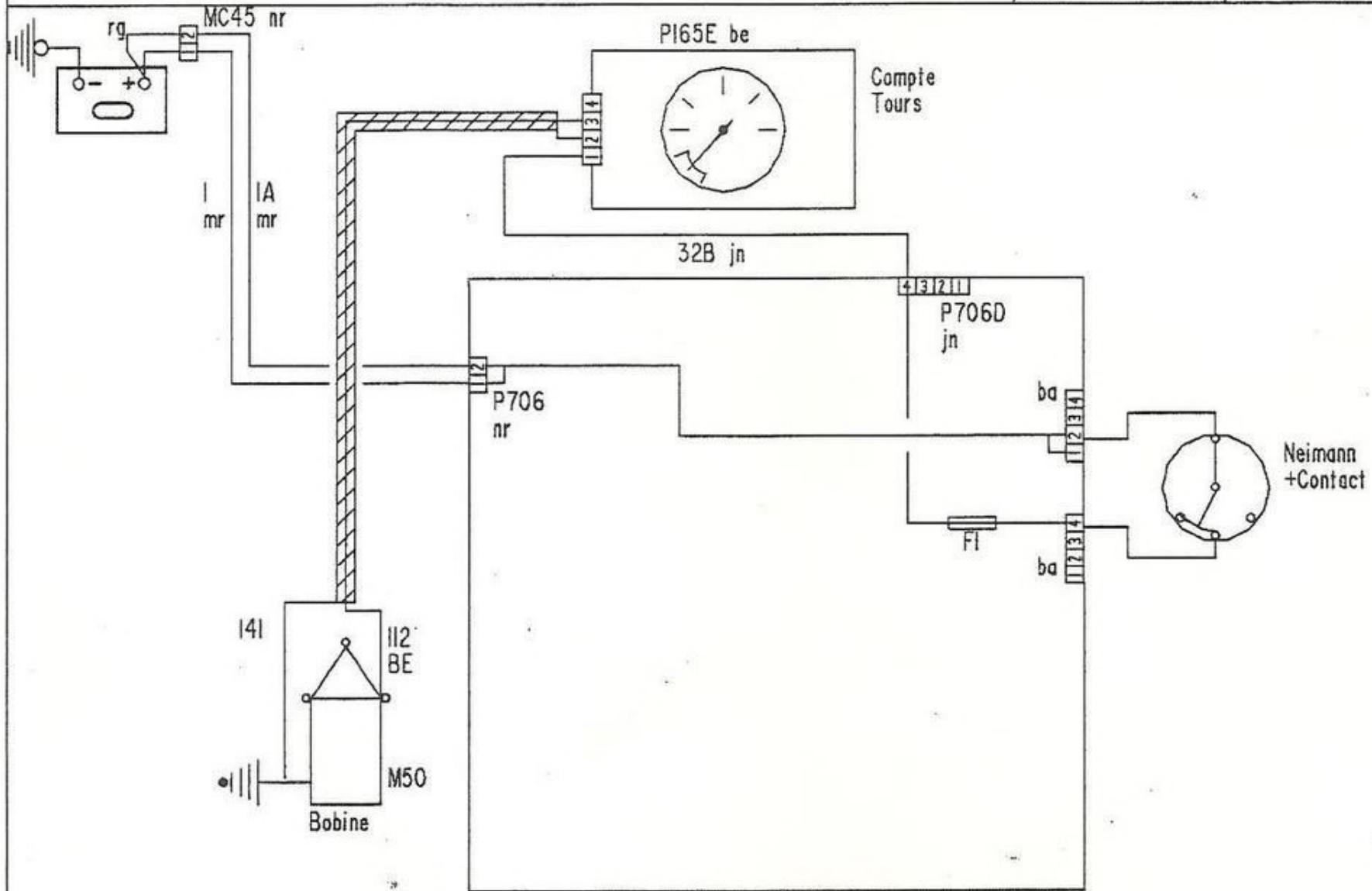

TYPES CONCERNES:
 -205ESS
 -205DSL

TEM.: STOP, PRESS. HUILE 6
 TEMP. EAU, NIVEAU EAU 1

A JOUR LE: 20-06-85

NOM: VIGNES

TEL: 3162

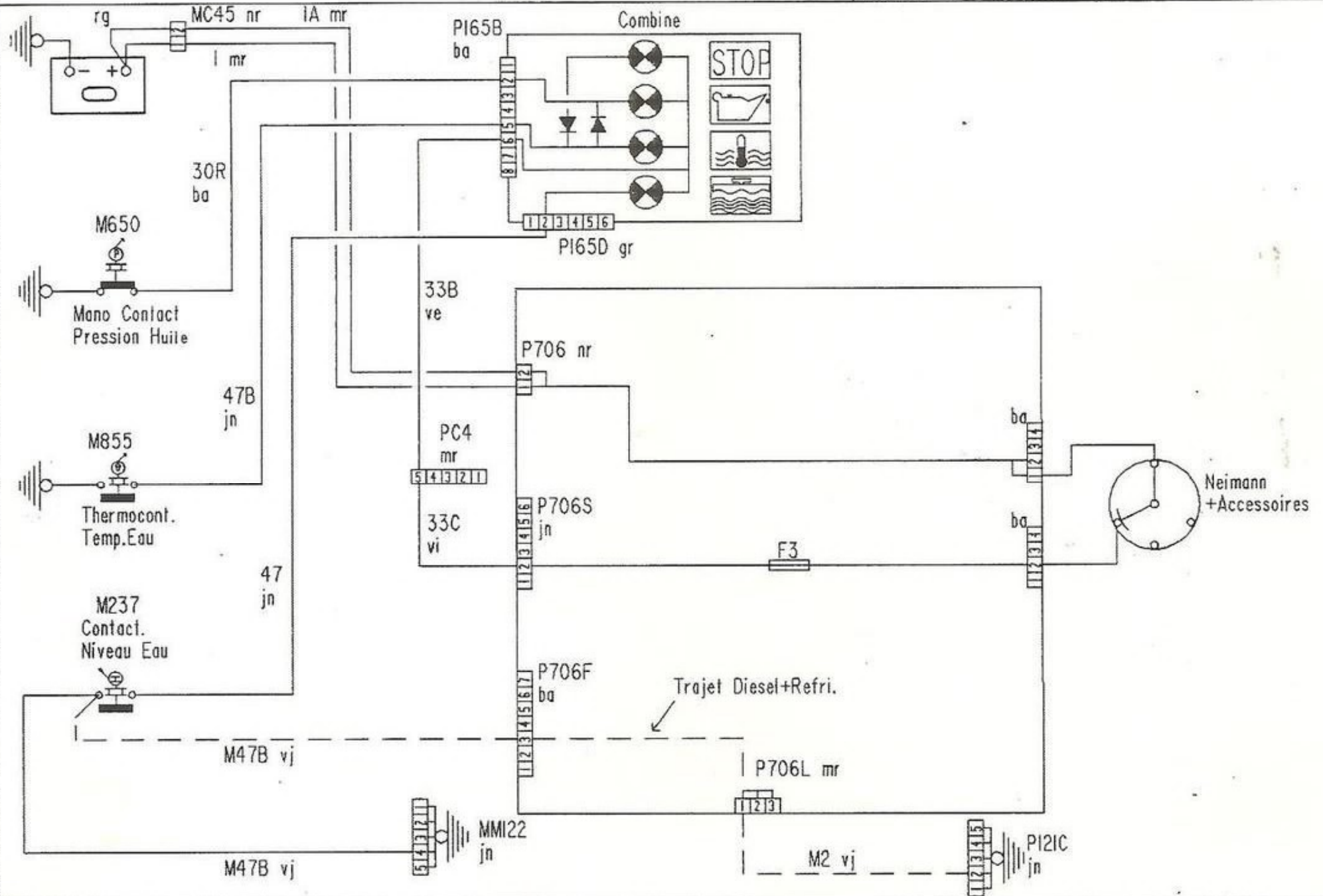

TEMOINS:

- STOP
- Temperature Eau
- Niveau Eau
- Pression d'Huile

TYPE CONCERNE:
-205GTI

TEMOINS COMBINE

7
1

A JOUR LE: 20-06-85

NOM: VIGNES

TEL: 3162

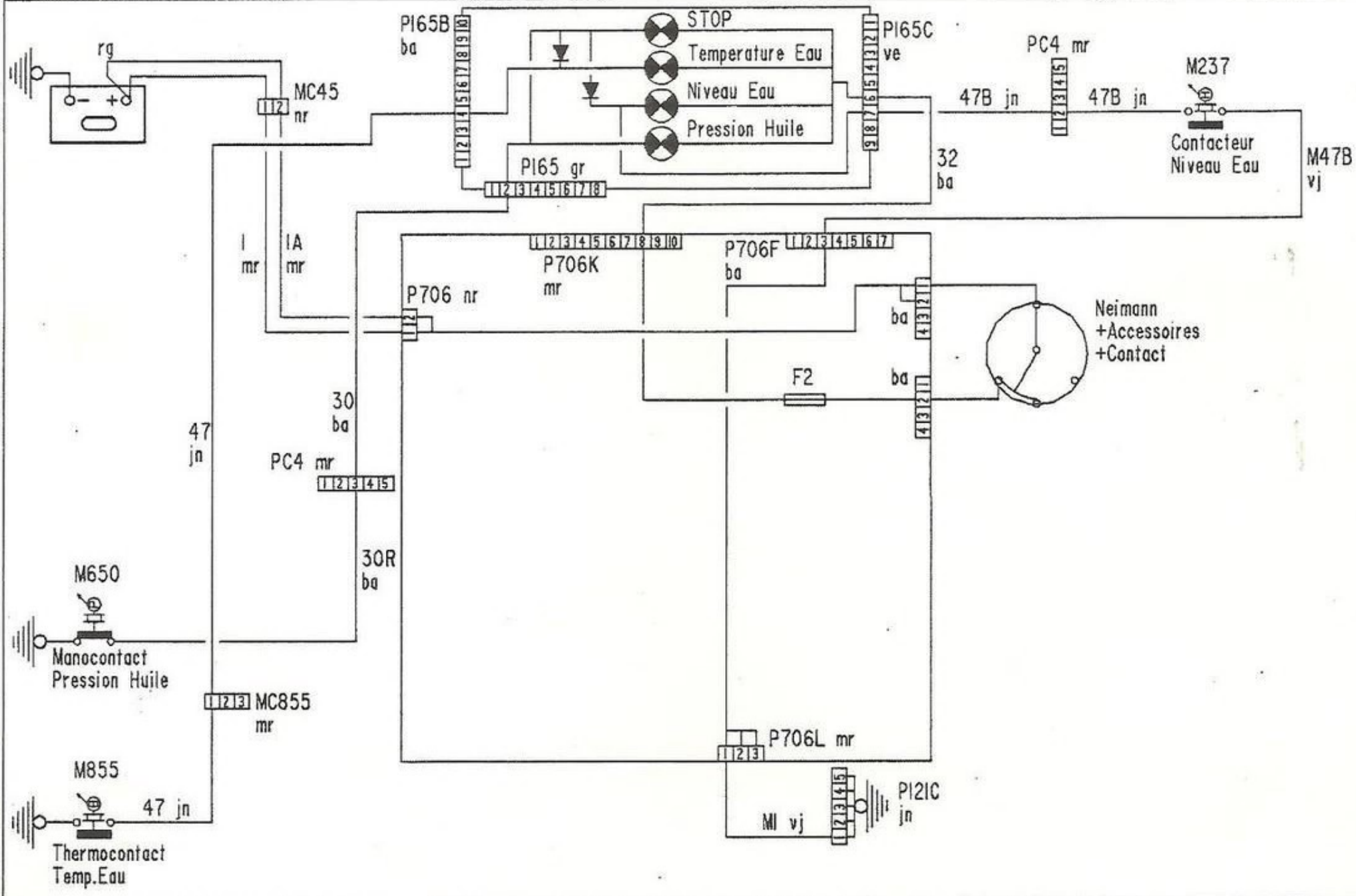

TYPES CONCERNES:

-205ESS

-205DSL

TEMOIN FREINS:
NIV. LIQU. USUR. PLAQ

8

1

A JOUR LE: 20-06-85

NOM: VIGNES

TEL: 3162

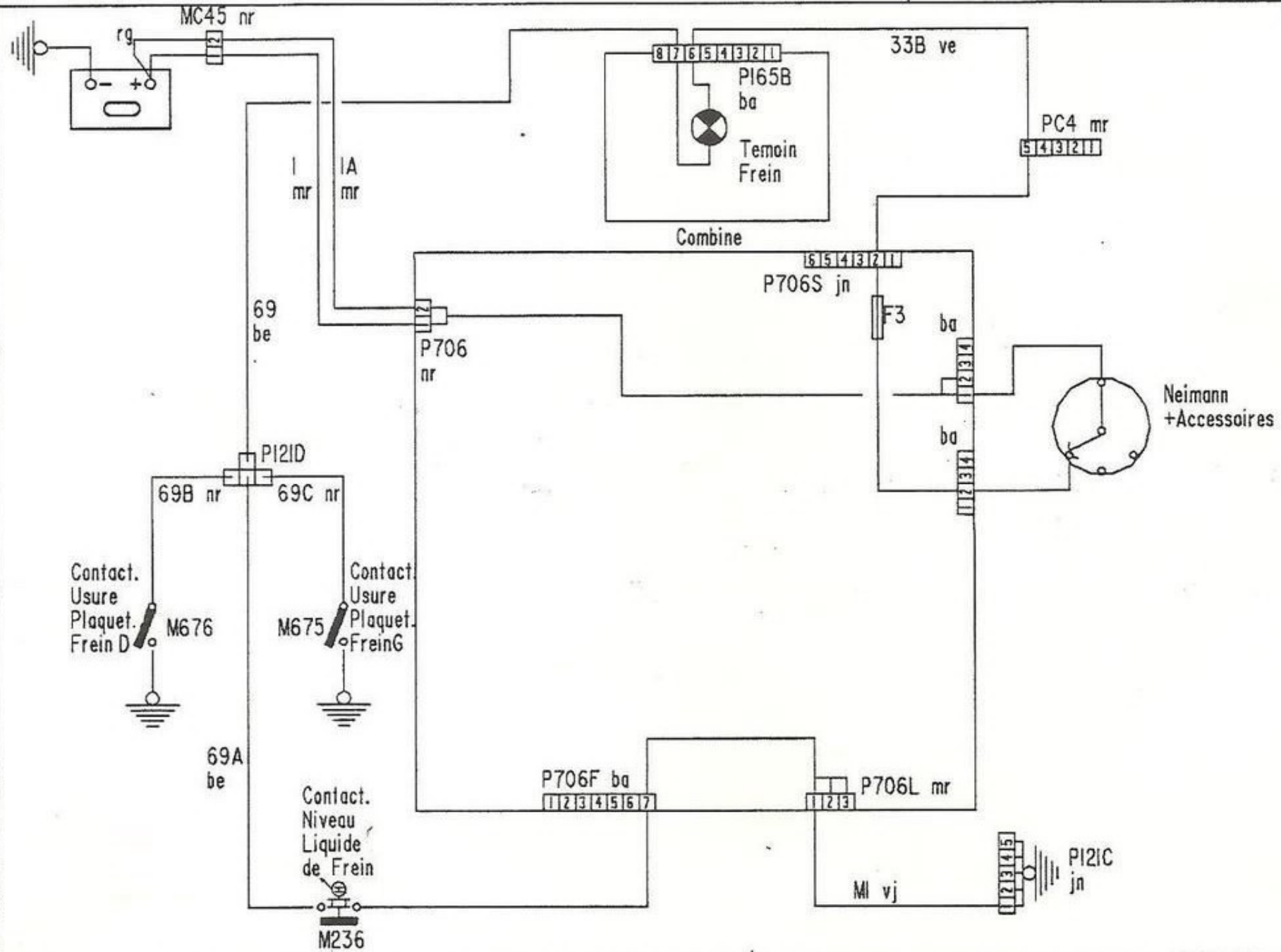

TYPE CONCERNE:
205GTI

TEMOIN D'USURE PLAQUETTES FREINS

9
1

A JOUR LE: 20-06-85

NOM: VIGNES

TEL: 3162

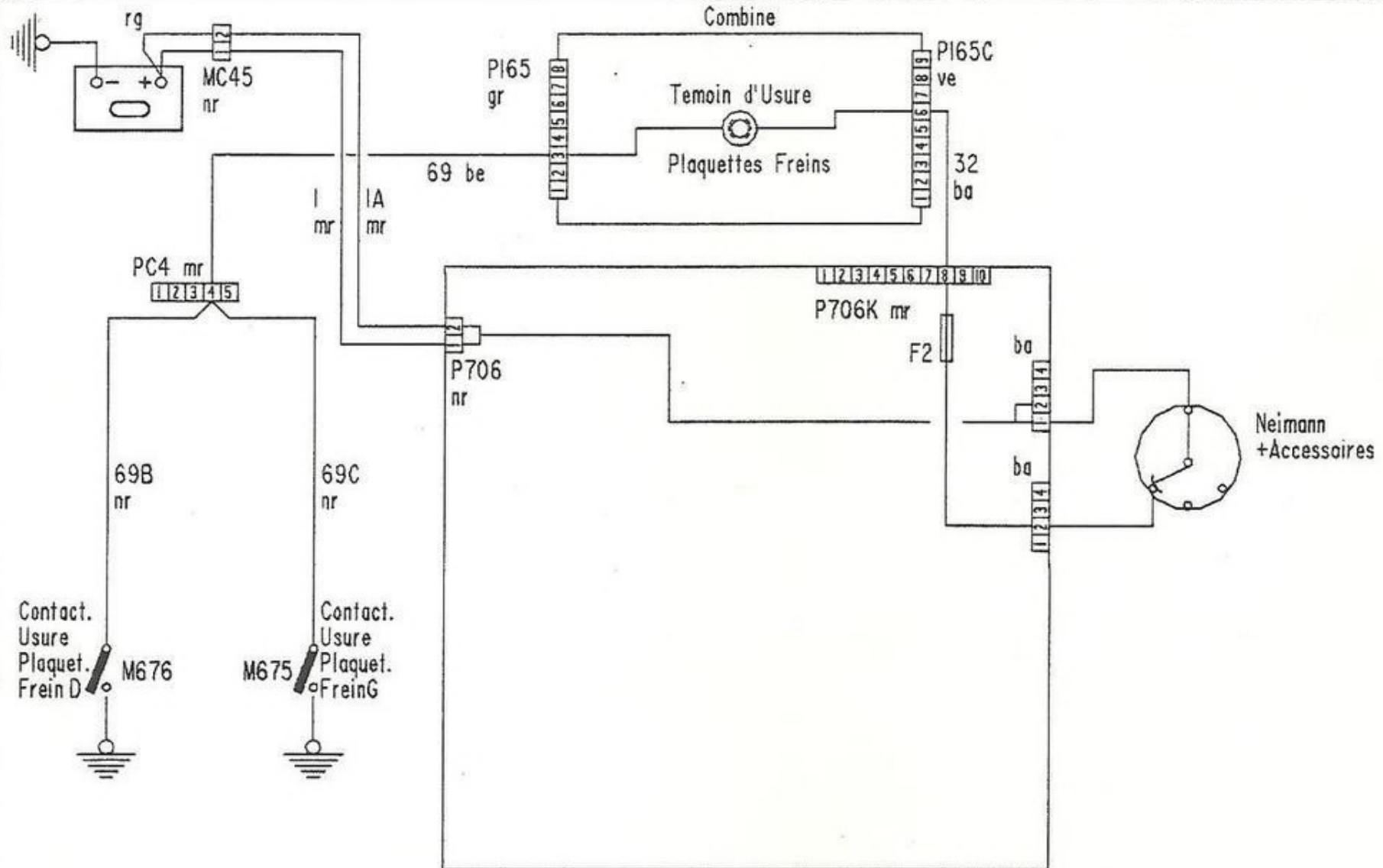

TYPE CONCERNE
-205DSL

DETECTEUR PRESENCE D'EAU DANS GASOIL

10
1

A JOUR LE: 20-06-85

NOM: VIGNES

TEL: 3162

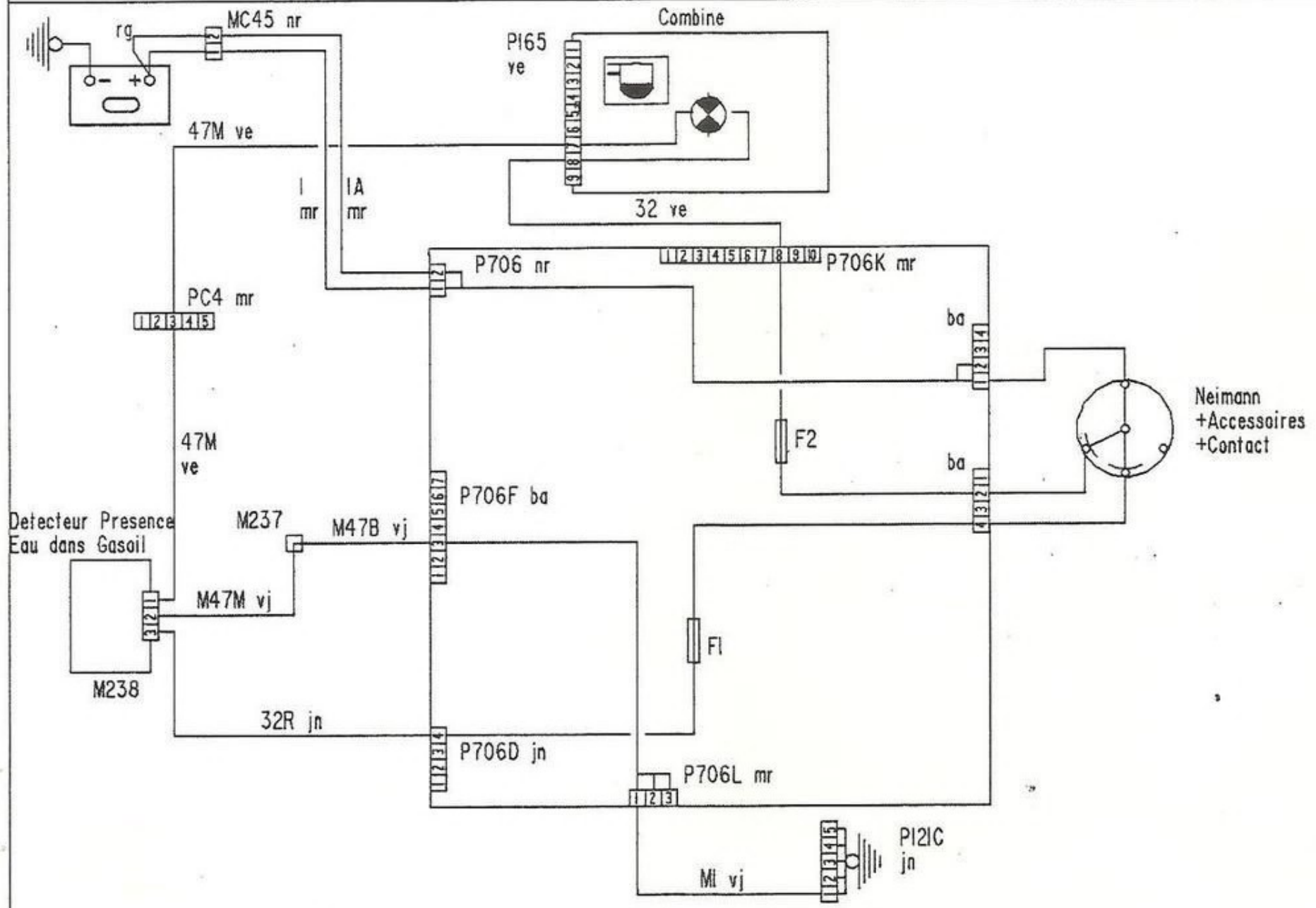

TYPE CONCERNE:
-205DSL

TEMOIN TEMPERATURE HUILE

12
1

A JOUR LE: 20-06-85

NOM: VIGNES

TEL: 3162

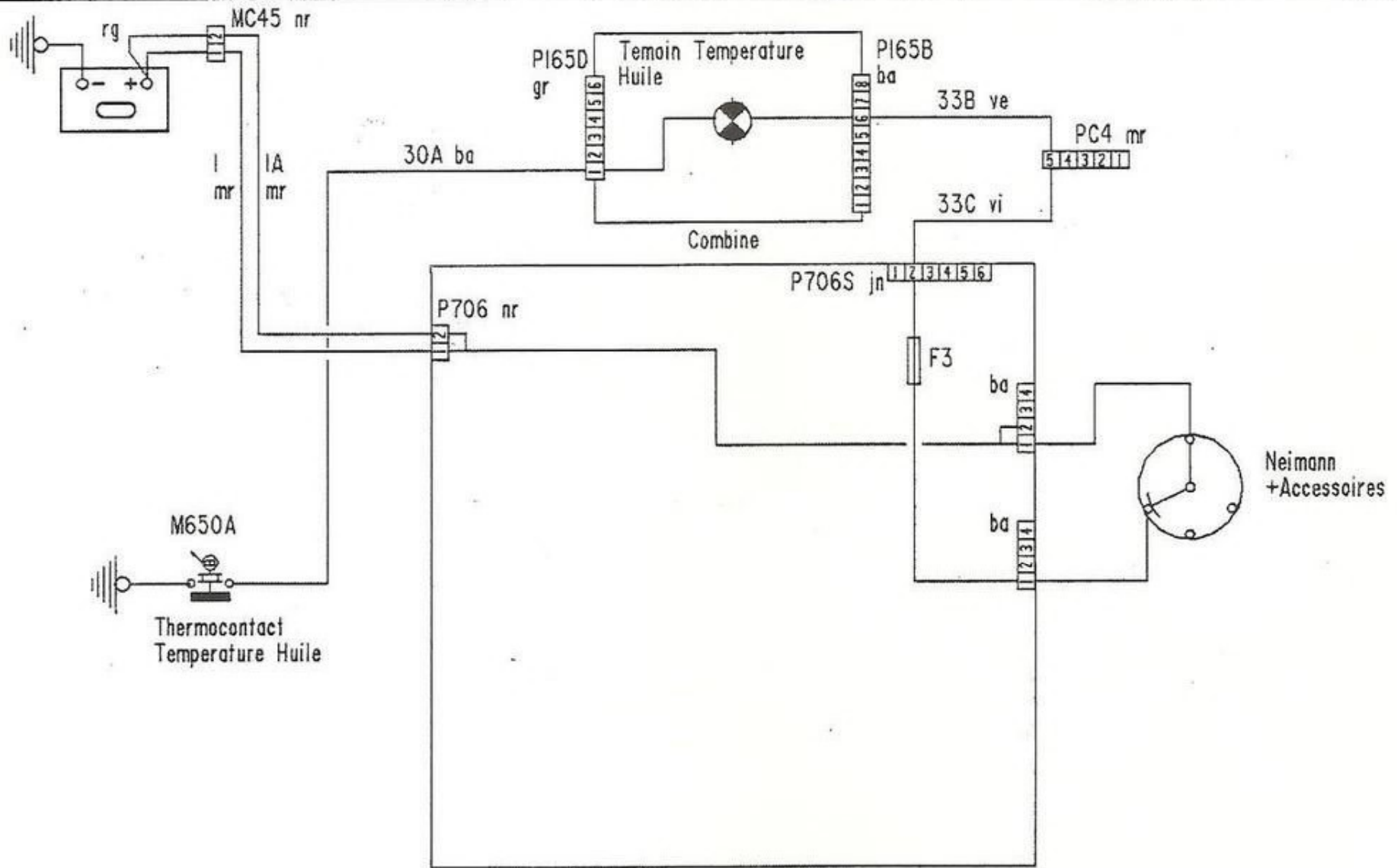

TYPE CONCERNE:
205GT1

RECEPTEURS COMBINE 13

A JOUR LE: 20-06-85

NOM: VIGNES

TEL: 3162

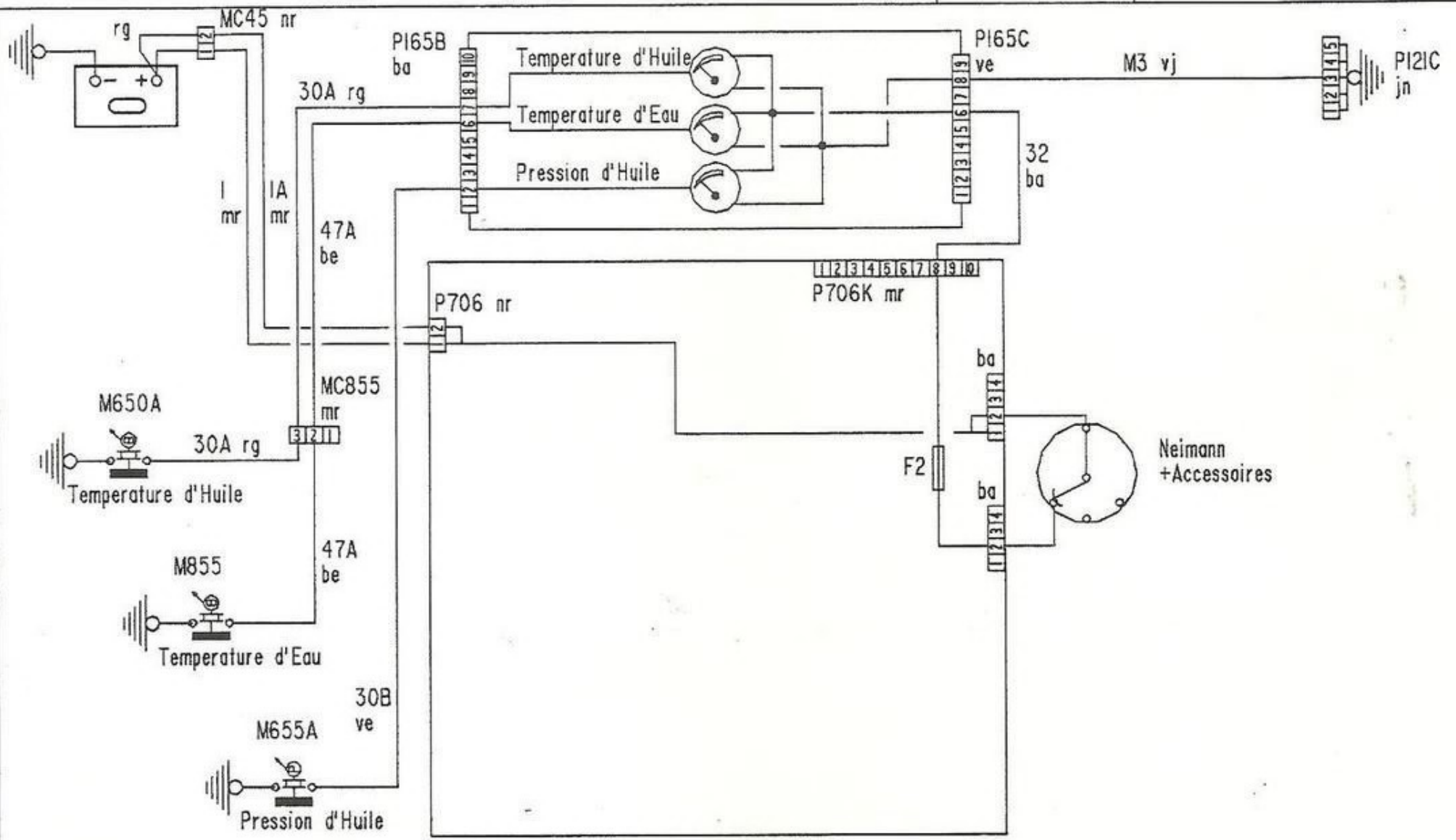

TYPE CONCERNE:
-205GLD FINLANDE

RECEPTEUR TEMPERATURE EAU

13
2

A JOUR LE: 20-06-85

NOM: VIGNES

TEL: 3162

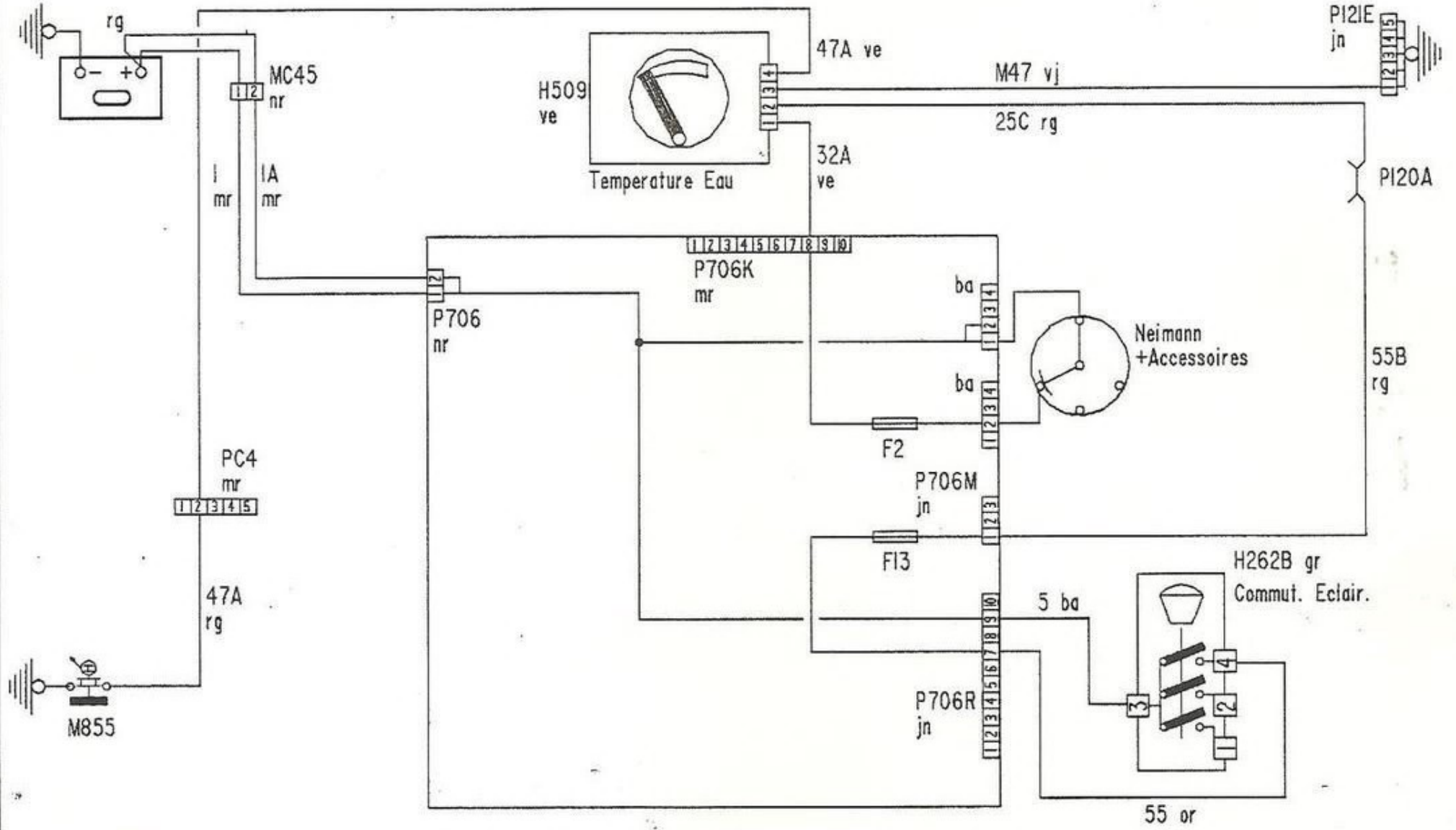

TYPES CONCERNES:
-205ESS
-205DSL

AVERTISSEUR

14
1

A JOUR LE: 20-06-85

NOM: VIGNES

TEL: 3162

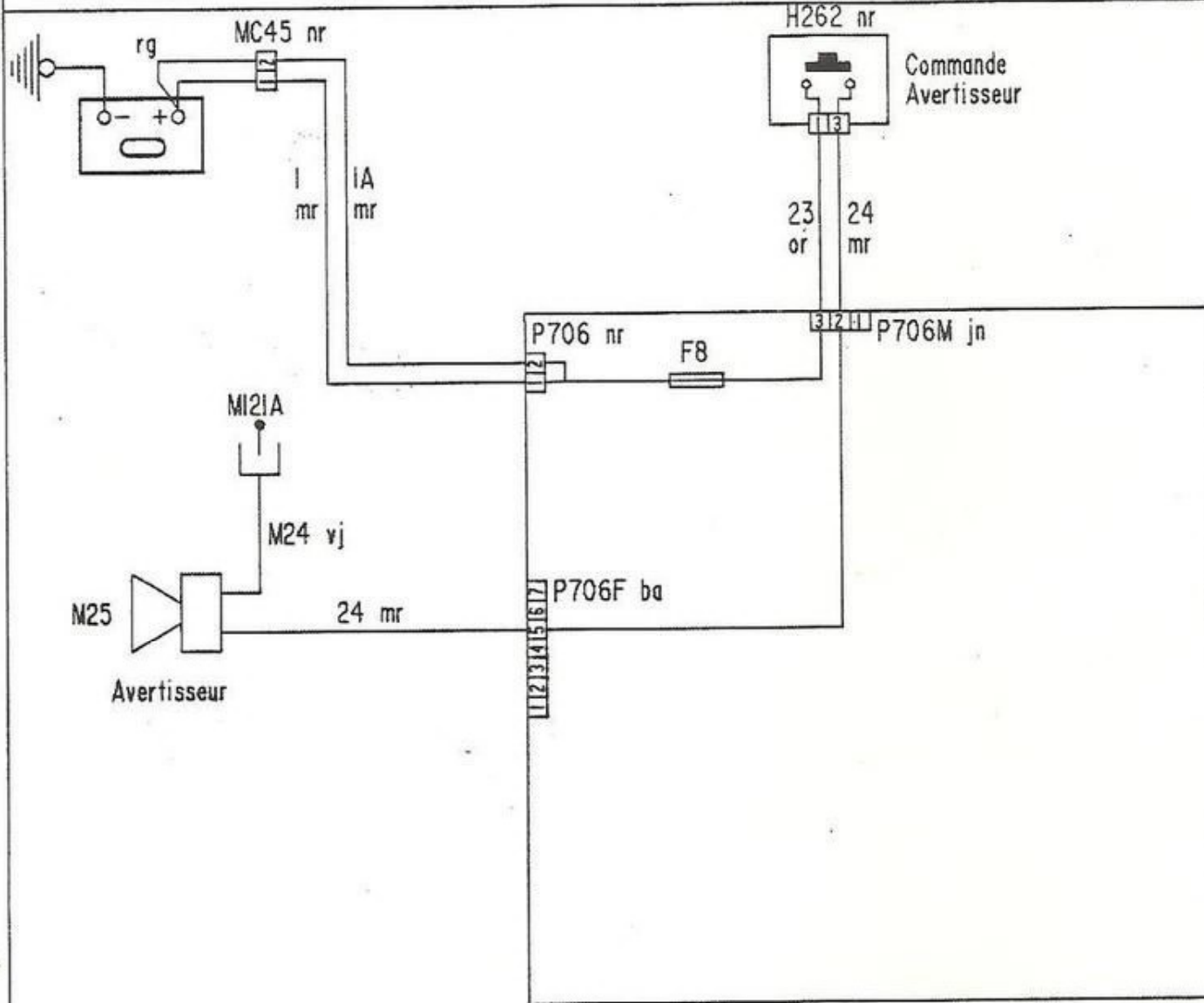

TYPE CONCERNE:
-205GTI

AVERTISSEUR

14
2

A JOUR LE: 20-06-85

NOM: VIGNES

TEL: 3162

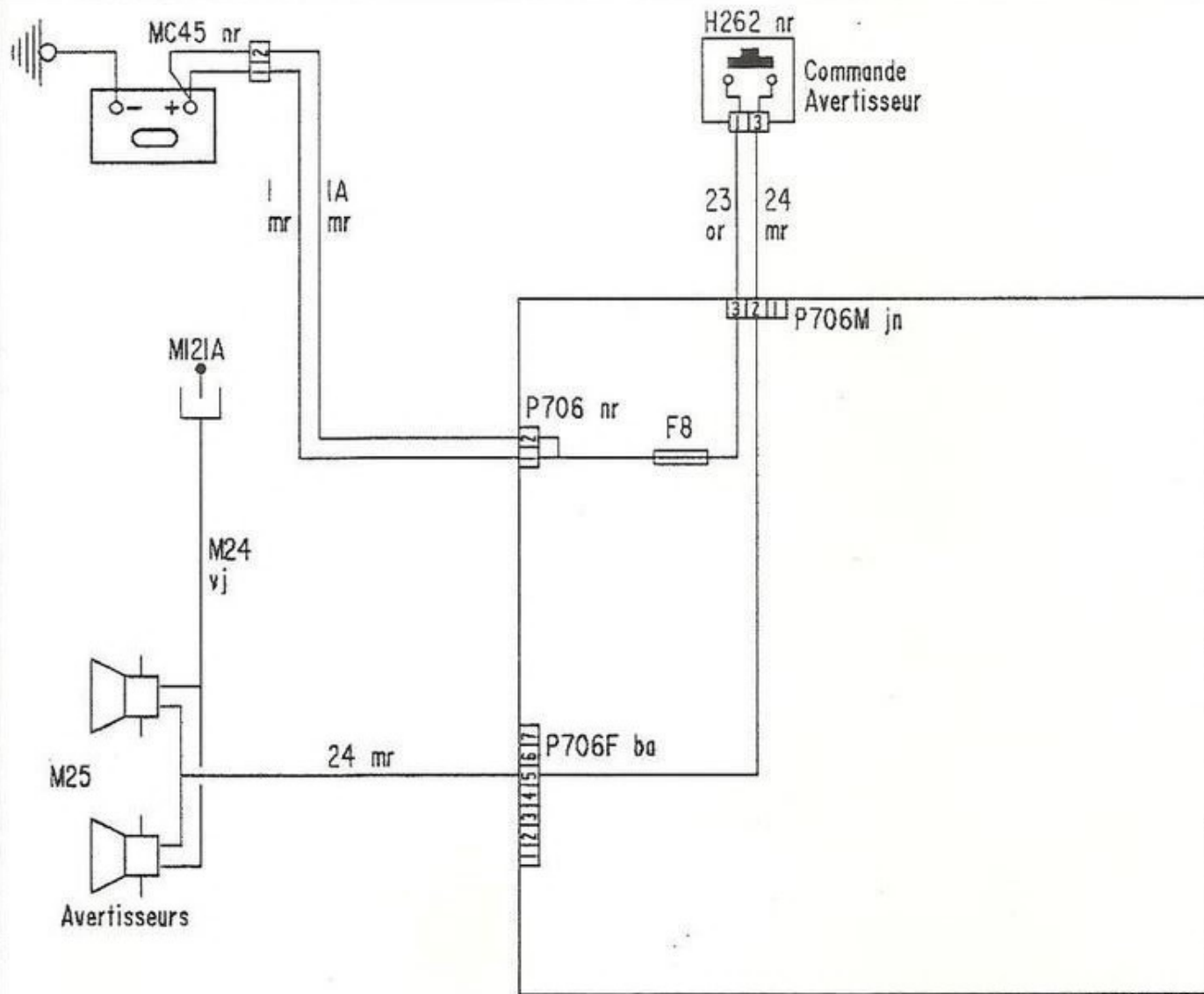

TYPES CONCERNES:
-205ESS
-205DSL

FEUX DE POSITION

15
1

A JOUR LE: 20-06-85

NOM: VIGNES

TEL: 3162

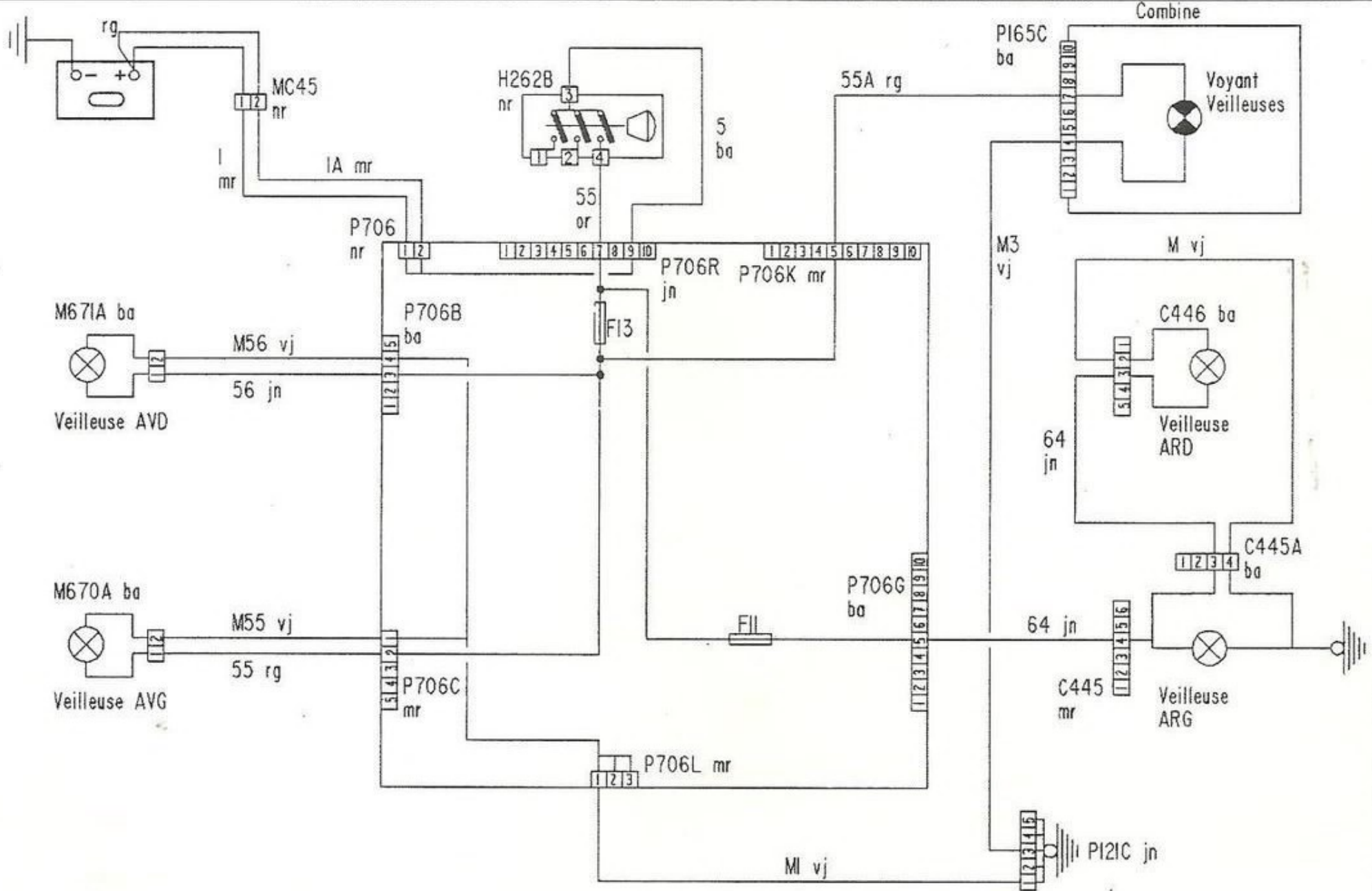

TYPE CONCERNE:
-205GT1

FEUX DE POSITION

15
2

A JOUR LE: 20-06-85

NOM: VIGNES

TEL: 3162

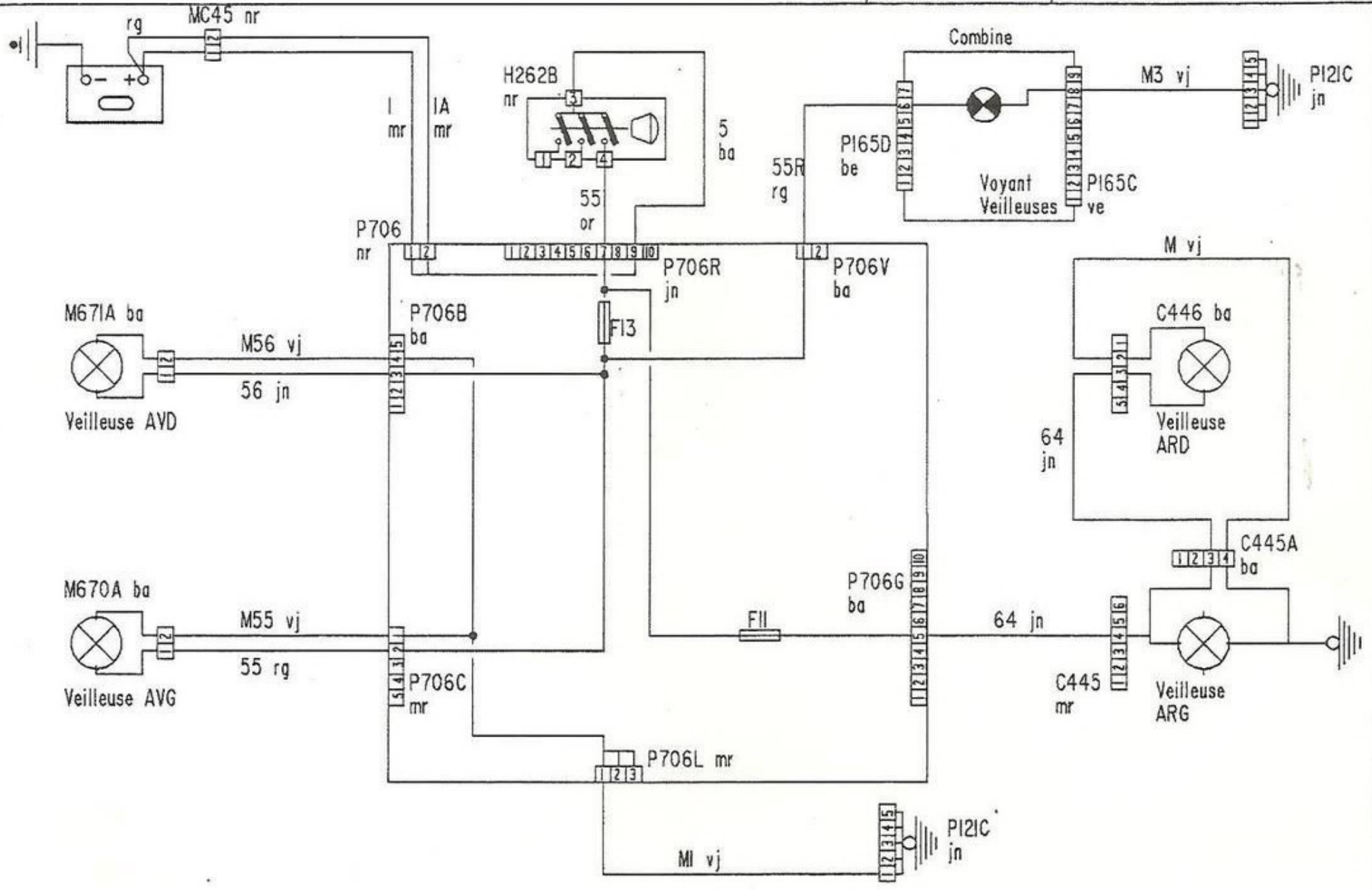

TYPES CONCERNES:
-205ESS
-205DSL

FEUX DE CROISEMENT

16
1

A JOUR LE: 20-06-85

NOM: VIGNES

TEL: 3162

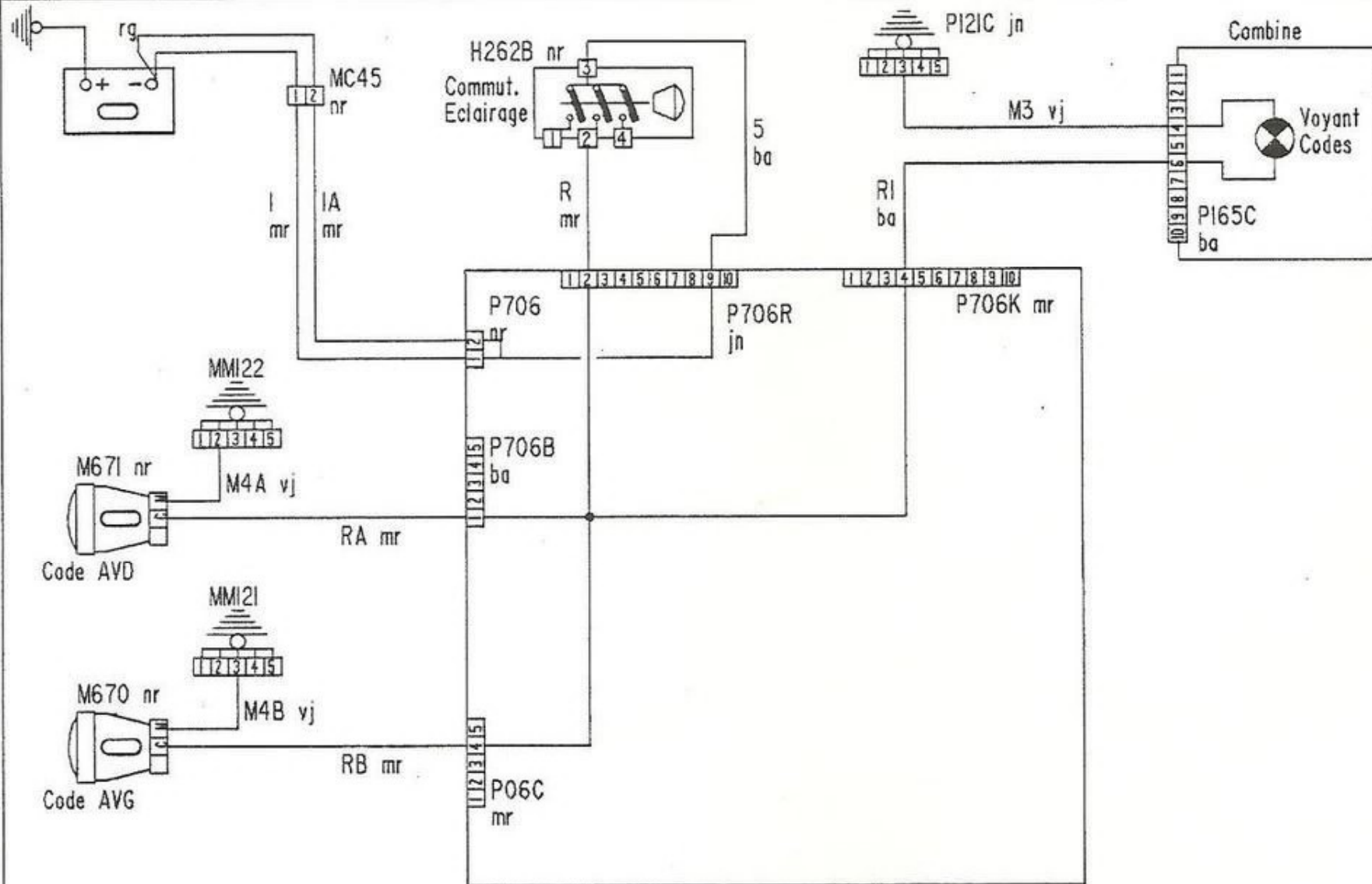

TYPE CONCERNE:
-205GT1

FEUX DE CROISEMENT

16
2

A JOUR LE: 20-06-85

NOM: VIGNES

TEL: 3162

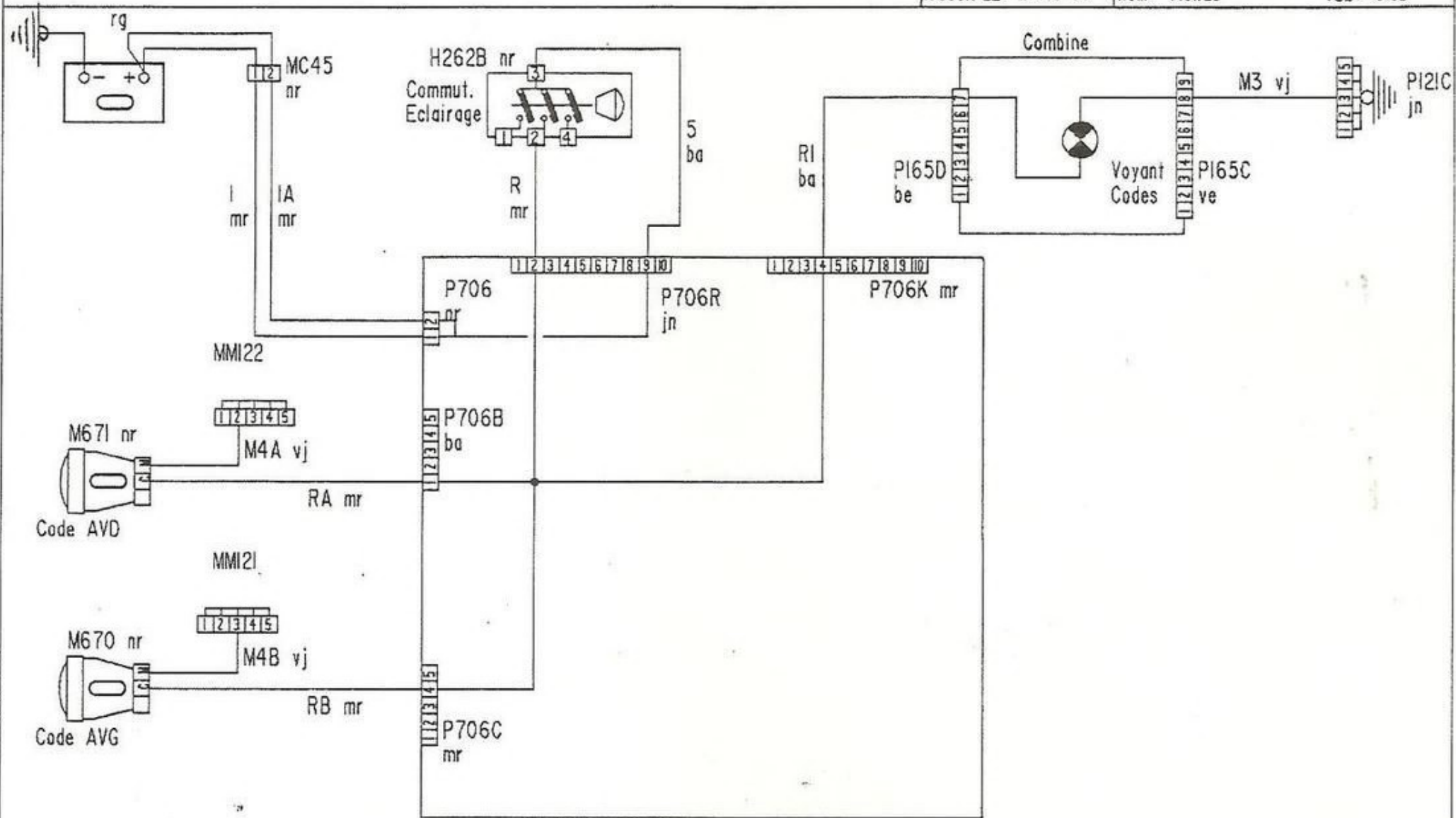

TYPES CONCERNES:
 -205ESS
 -205DSL

FEUX DE ROUTE

17
1

A JOUR LE: 20-06-85

NOM: VIGNES

TEL: 3162

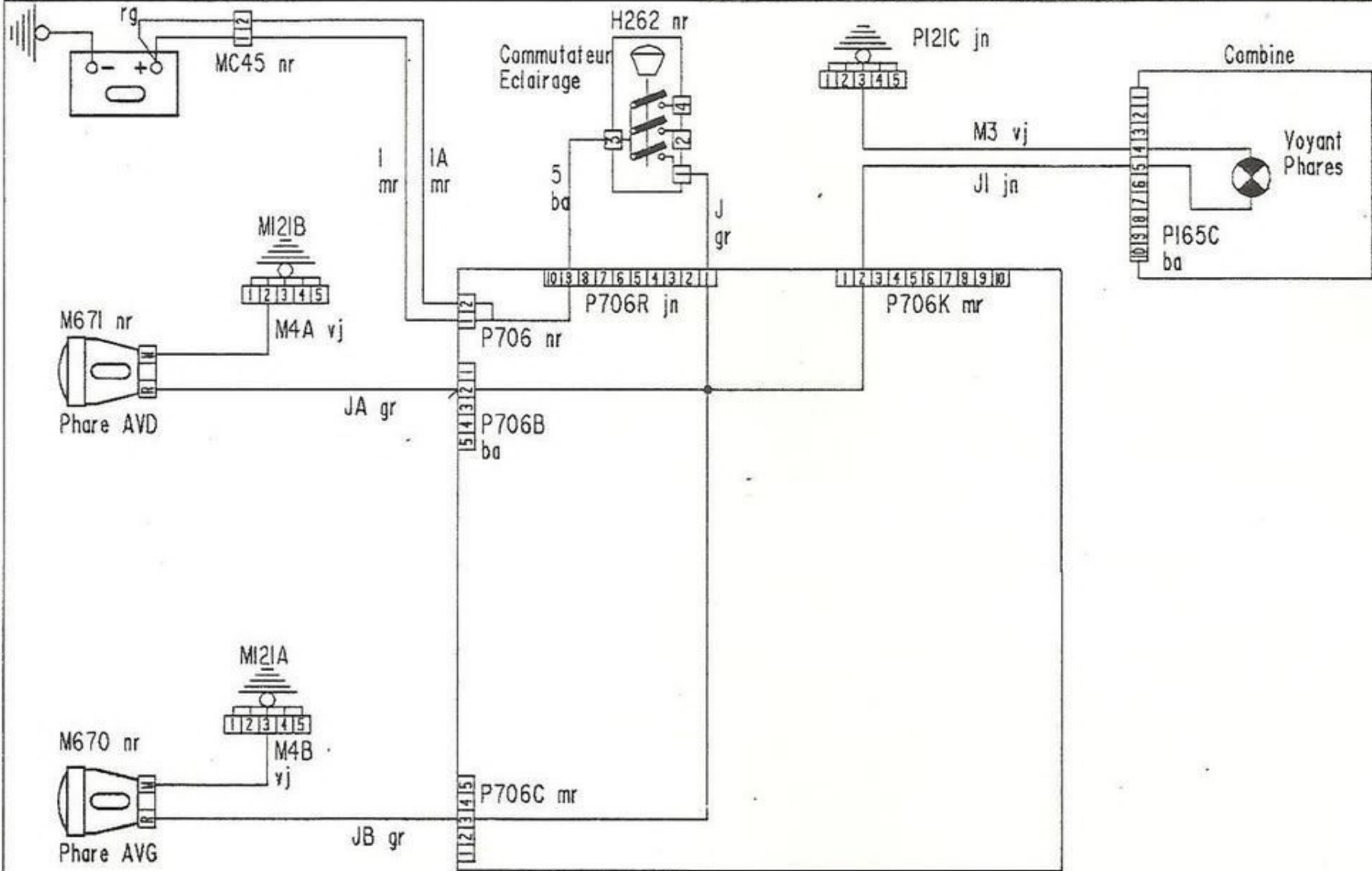

TYPE CONCERNE:
205GT1

FEUX DE ROUTE
FEUX LONGUE PORTEE

17
2

A JOUR LE: 20-06-85

NOM: VIGNES

TEL: 3162

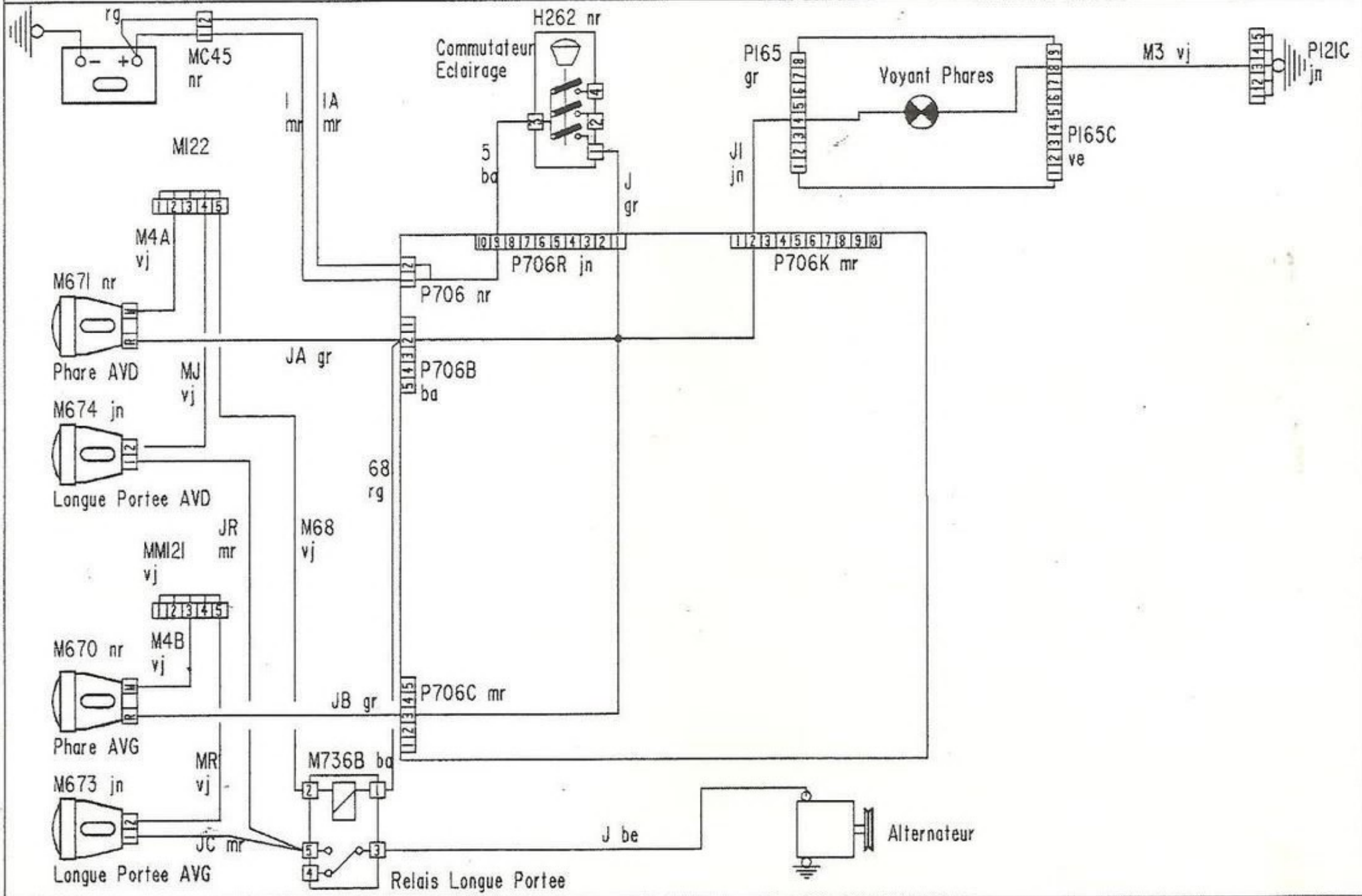

TYPE CONCERNE:
205GTI ESPAGNE

FEUX ANTIBROUILLARD AVANT

17
3

A JOUR LE: 20-06-85

NOM: VIGNES

TEL: 3162

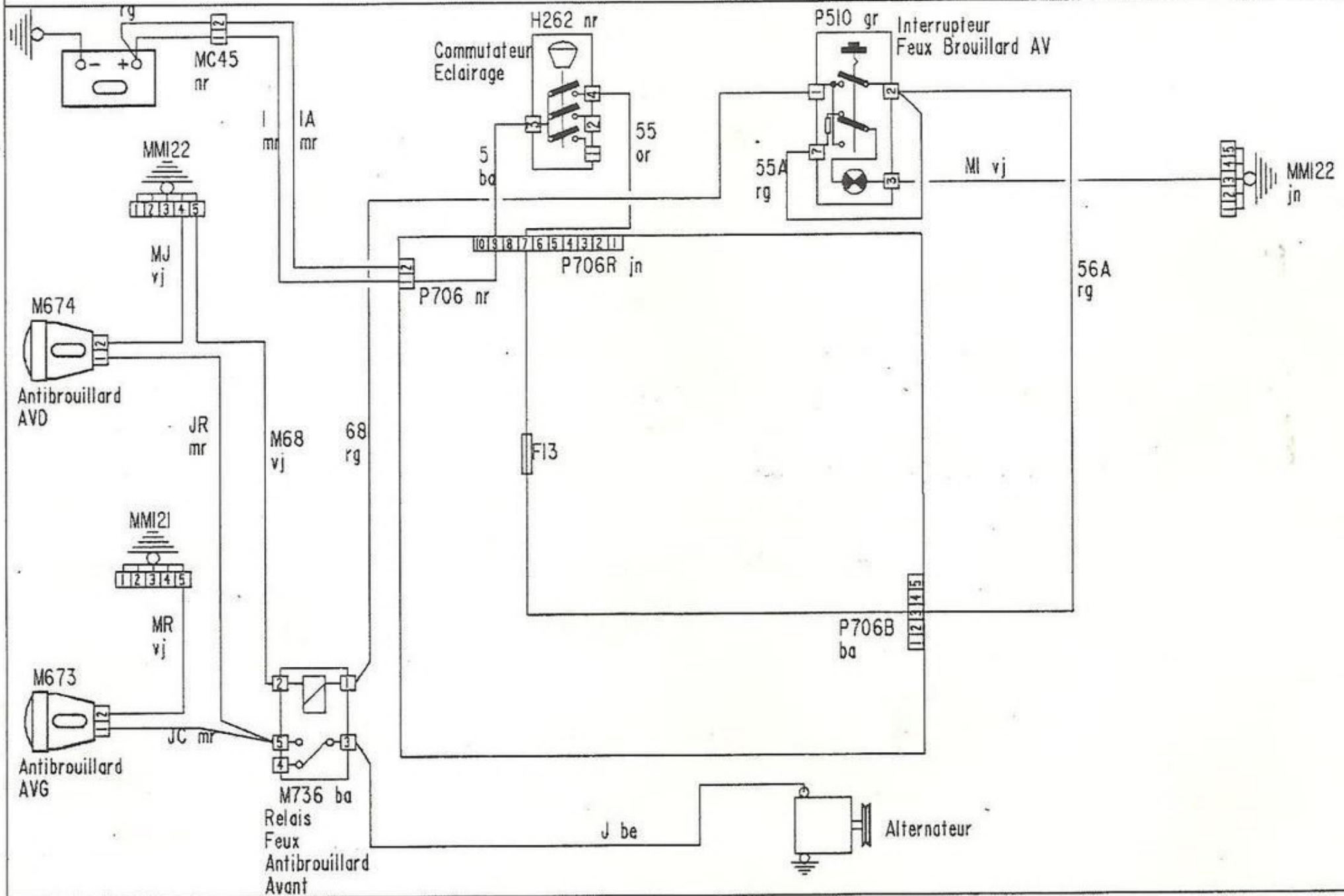

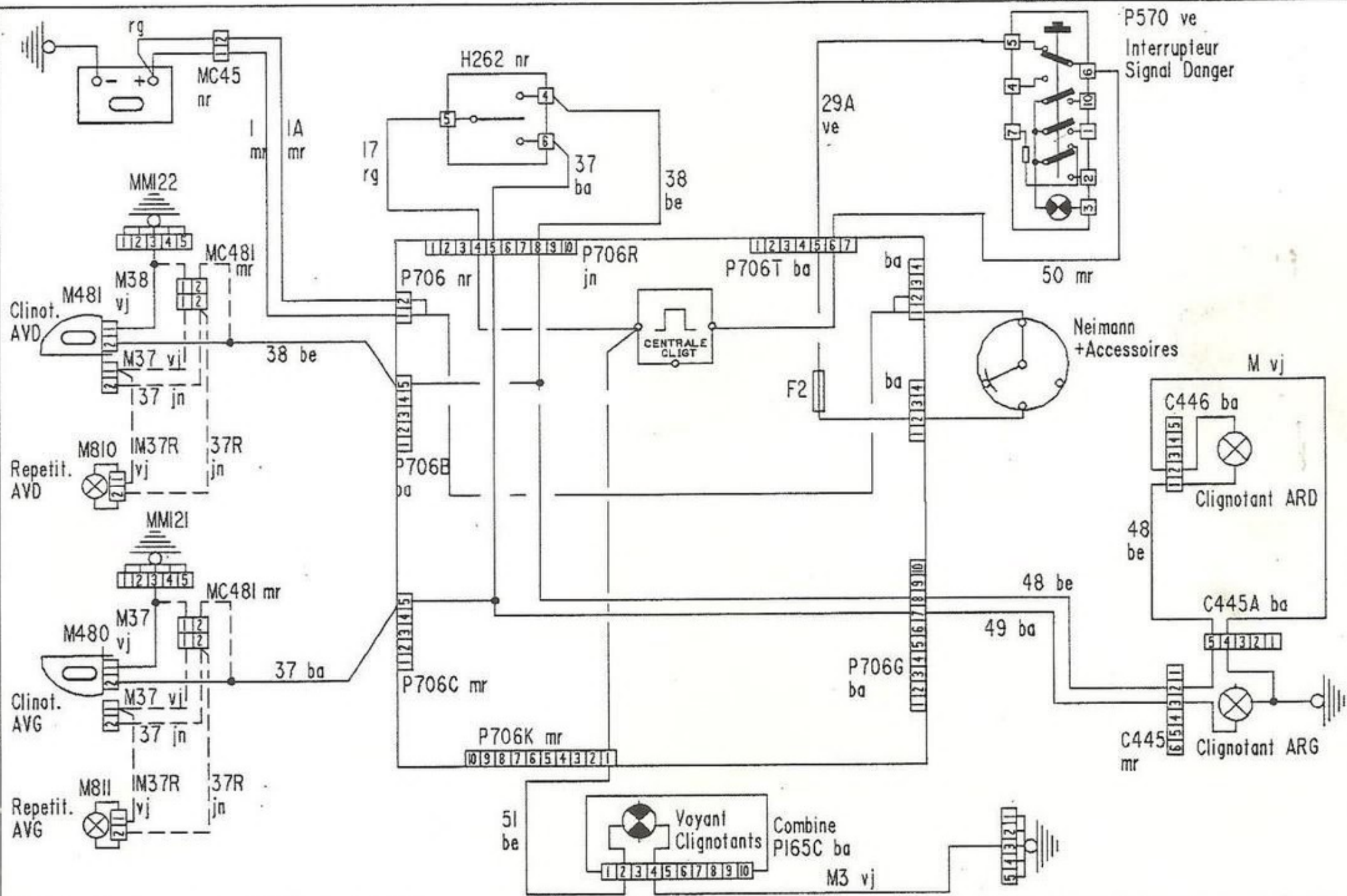

TYPE CONCERNE:
-205GTI

CLIGNOTANTS REPETITEURS

18
2

En Pointilles: Repetiteurs Clignotant

A JOUR LE: 20-06-85

NOM: VIGNES

TEL: 3162

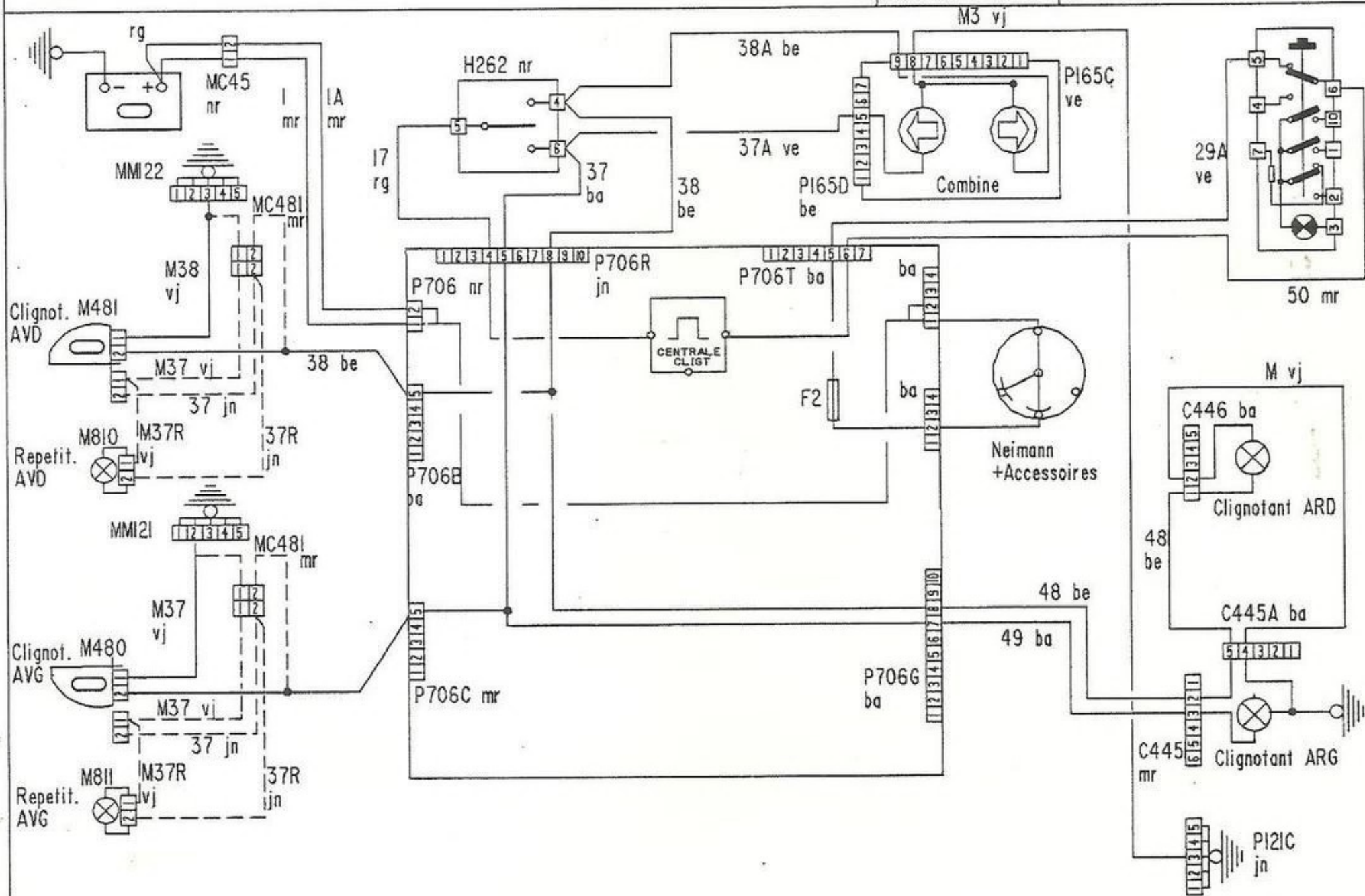

TYPES CONCERNES:
-205ESS
-205DSL

SIGNAL DANGER

19

A JOUR LE: 20-06-85

NOM: VIGNES

TEL: 3162

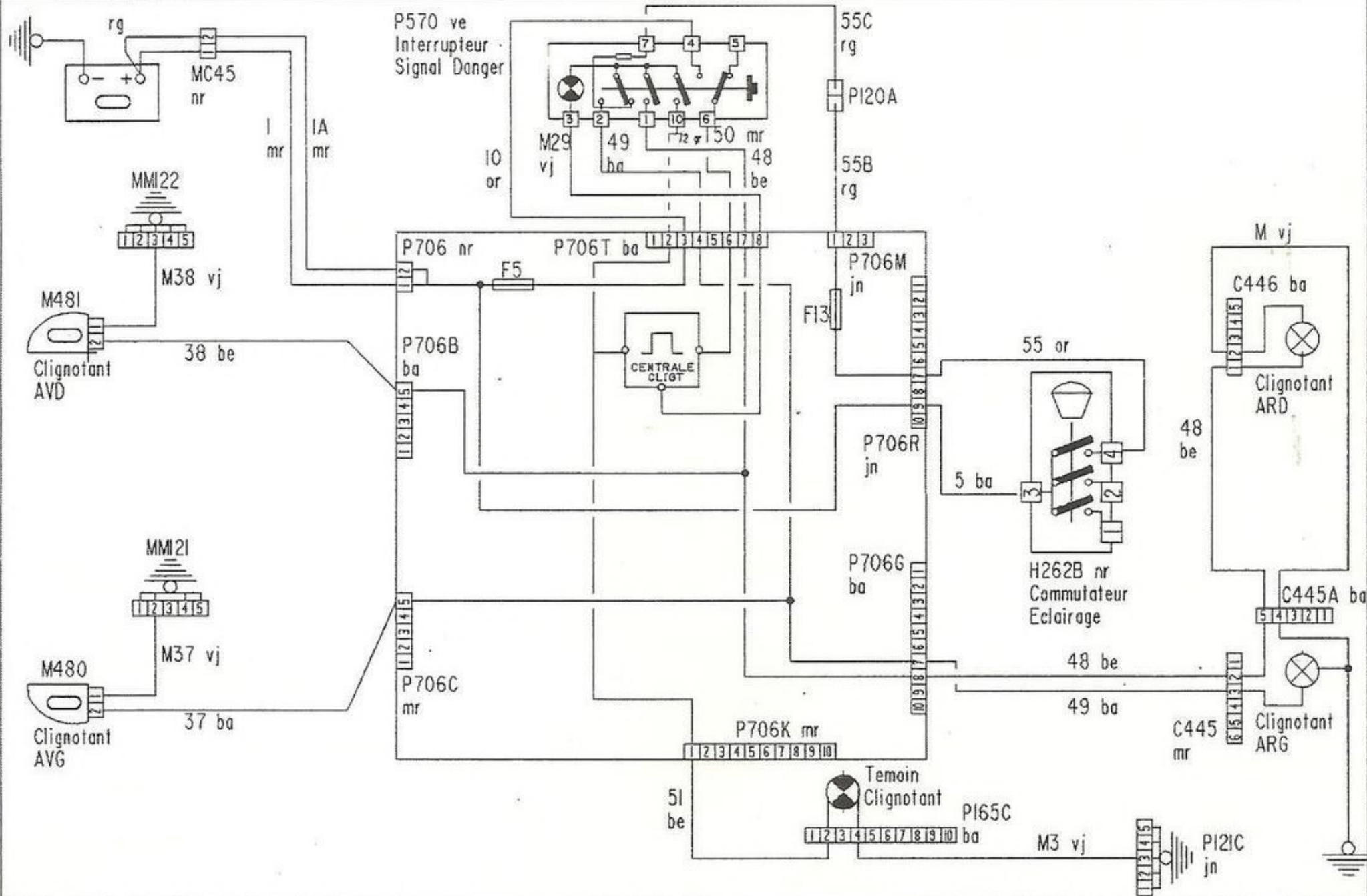

TYPE CONCERNE:
-205GT1

SIGNAL DANGER

19
2

A JOUR LE: 20-06-85

NOM: VIGNES

TEL: 3162

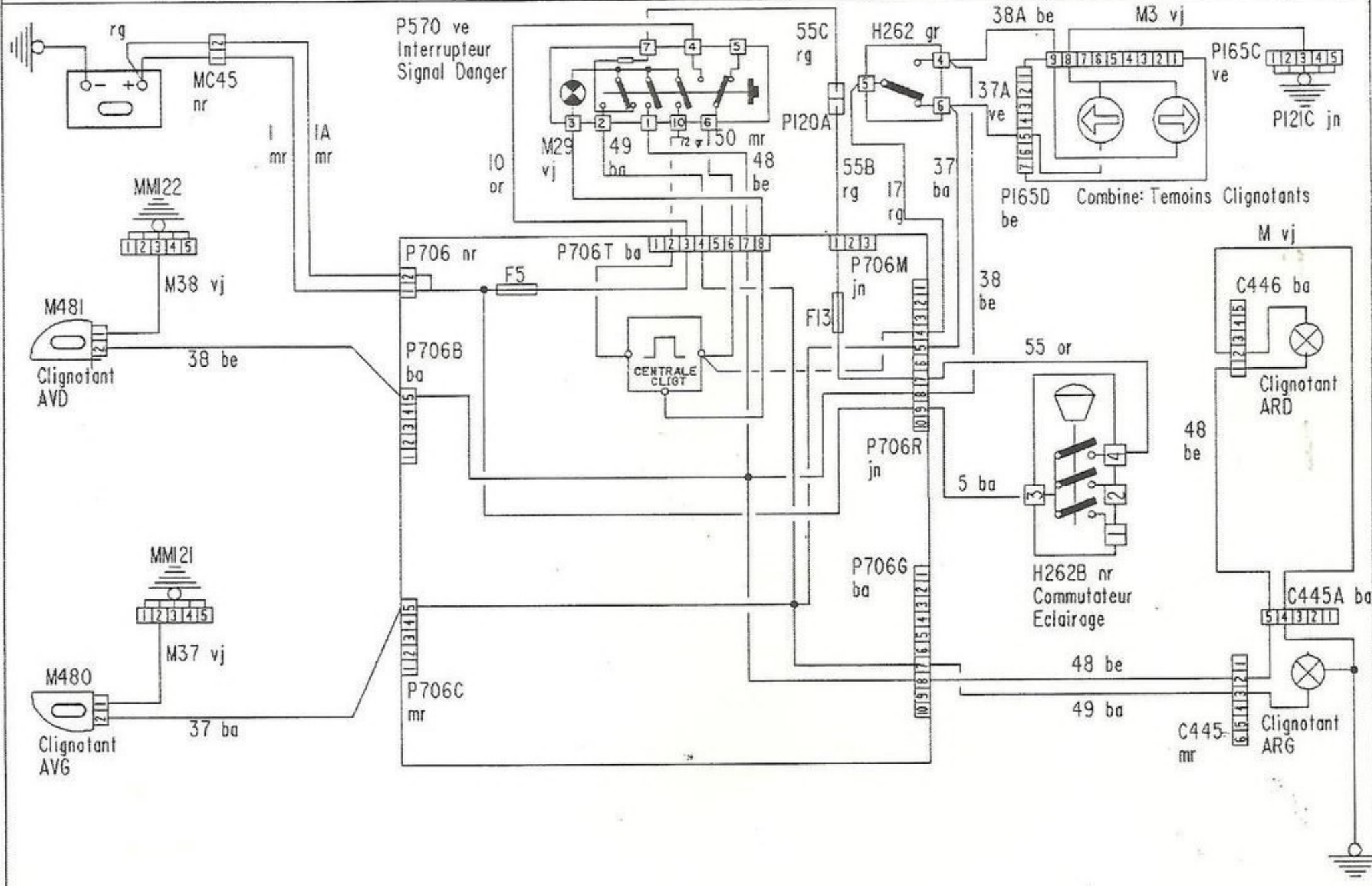

TYPES CONCERNES:
-205ESS
-205DSL

ESSUIE VITRE AV NON TEMPORISE

20
1

A JOUR LE: 20-06-85

NOM: VIGNES

TEL: 3162

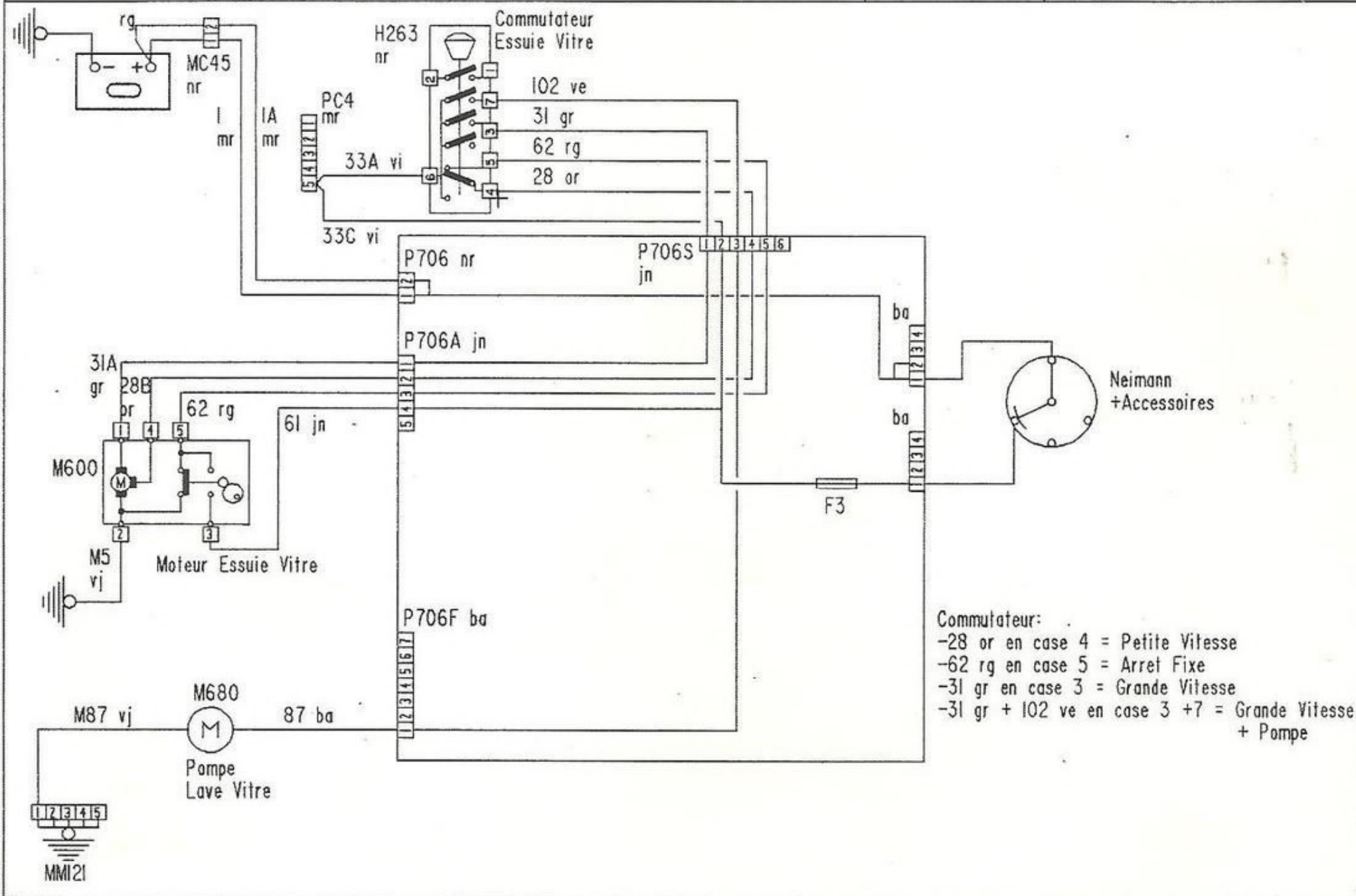

33A VIOLET EN POINTILLES: TRAJET GTI UNIQUEMENT

TYPES CONCERNES:
-205ESS
-205DSL
-205GTI

ESSUIE VITRE AVANT

21
1

A JOUR LE: 28-06-85

NOM: YIGNES

-TEL: 3162

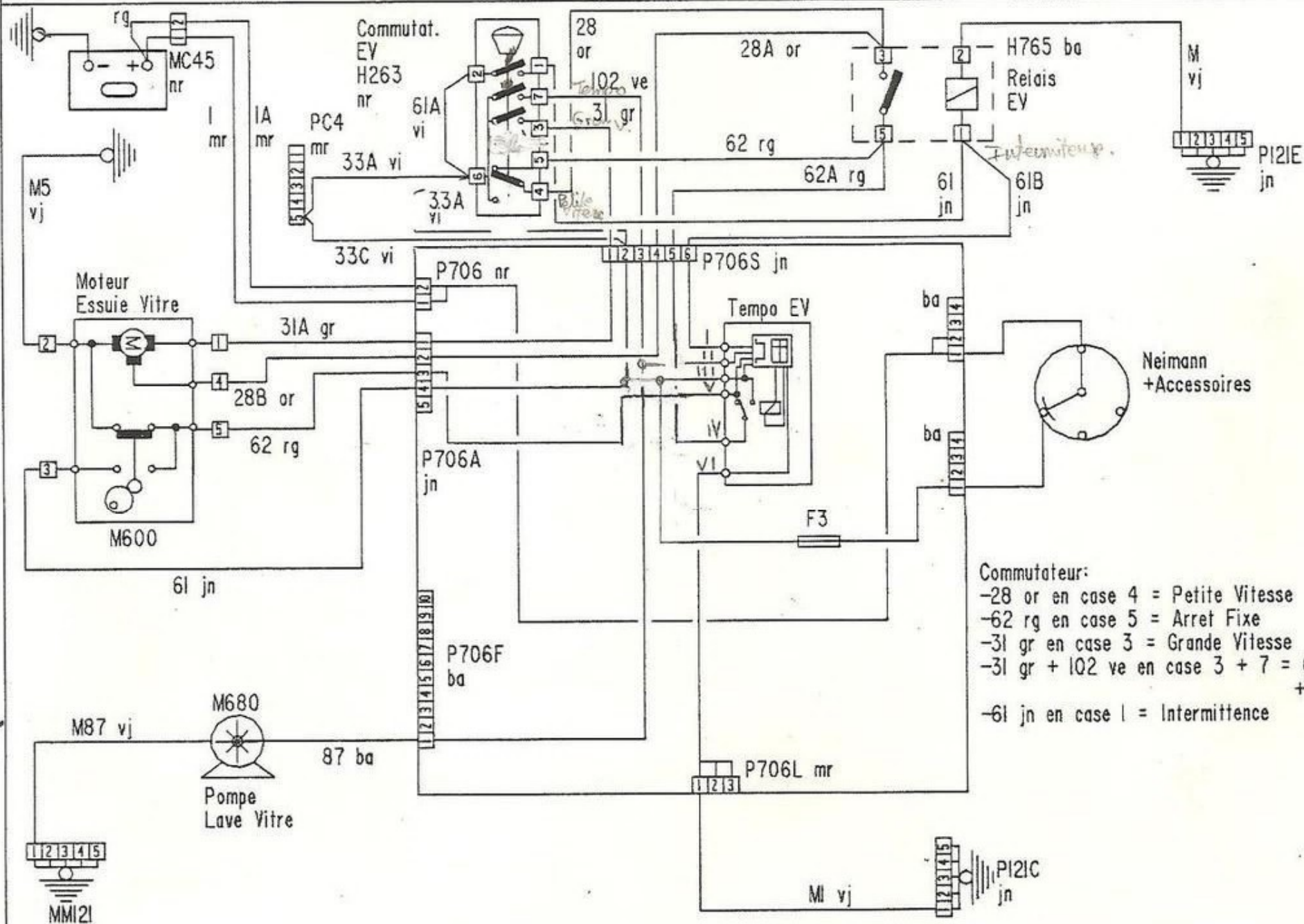

Commutateur:
-28 or en case 4 = Petite Vitesse
-62 rg en case 5 = Arret Fixe
-31 gr en case 3 = Grande Vitesse
-31 gr + 102 ve en case 3 + 7 = Grande Vitesse + Pompe
-61 jn en case 1 = Intermittence

TYPES CONCERNES:
-205ESS
-205DSL

ECLAIRAGE: FACADE CL
ALL. CIGARE COMBINE

22
1

A JOUR LE: 20-06-85

NOM: VIGNES

TEL: 3162

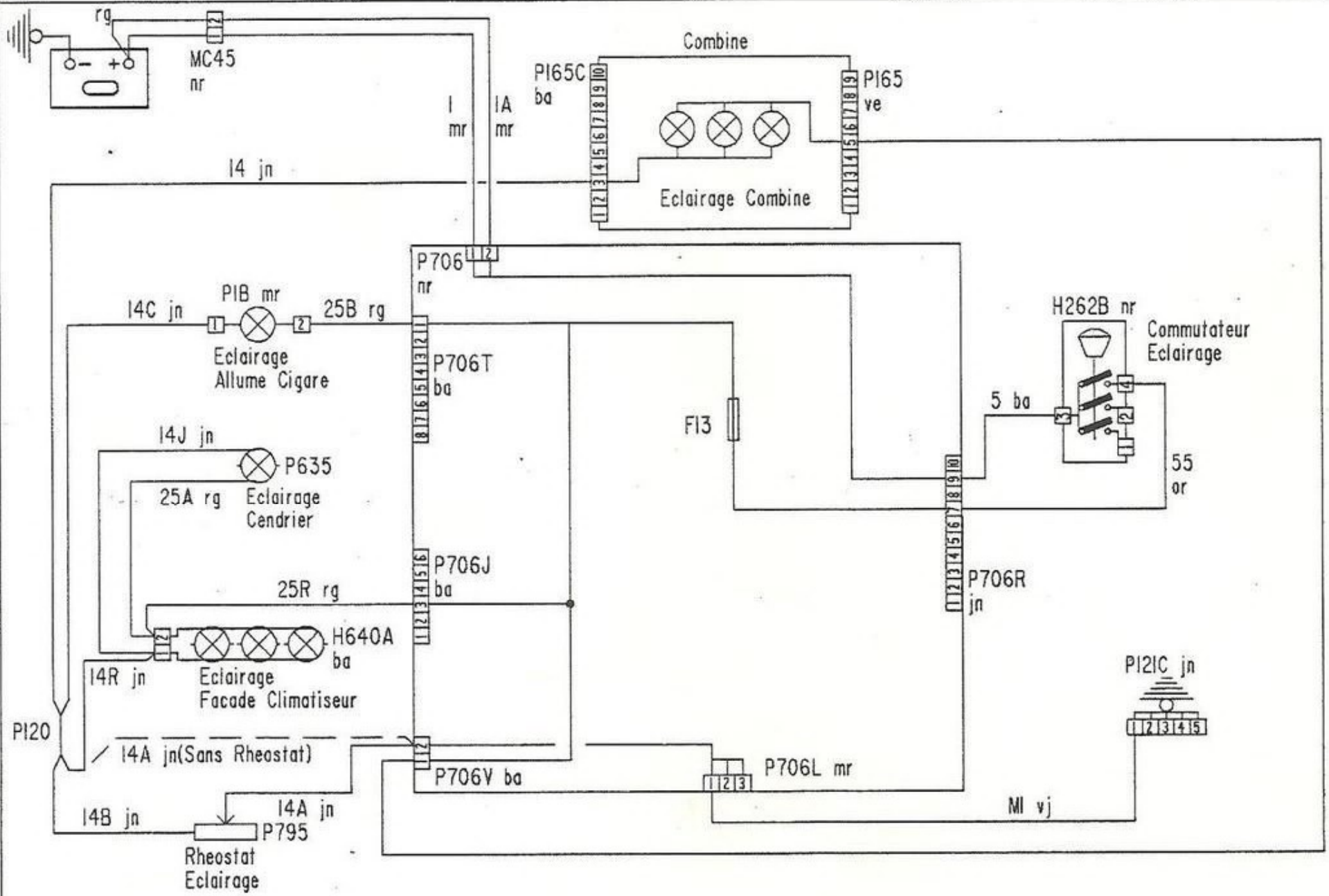

55R
rg

TYPE CONCERNE:
-205GT1

ECLAIRAGE: FACADE CL 22
ALL. CIGARE COMBINE 2

A JOUR LE: 20-06-85

NOM: VIGNES

TEL: 3162

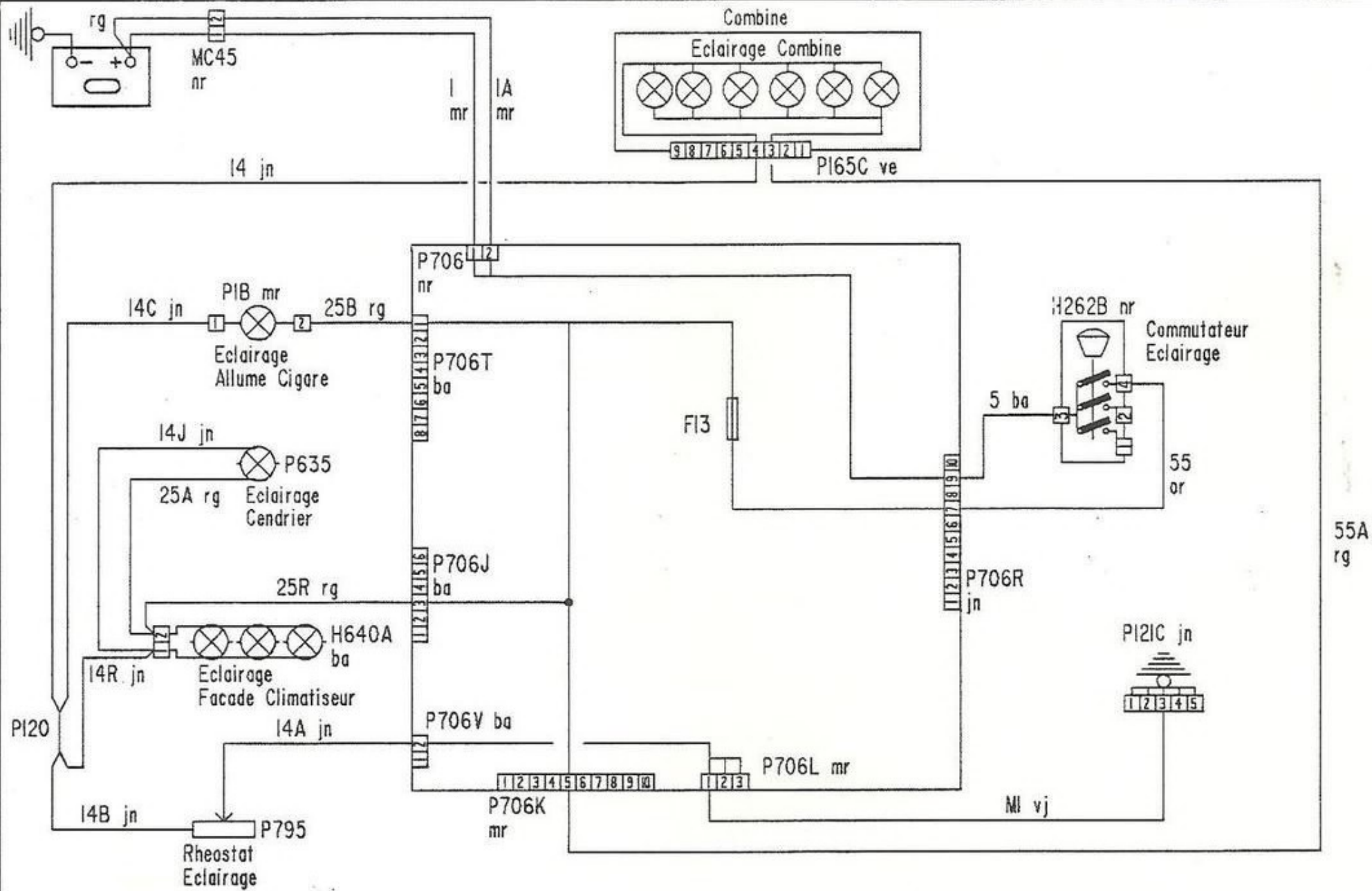

55A
rg

TYPES CONCERNES:
-205ESS
-205DSL

MONTRE AIGUILLES

23

A JOUR LE: 20-06-85

NOM: VIGNES

TEL: 3162

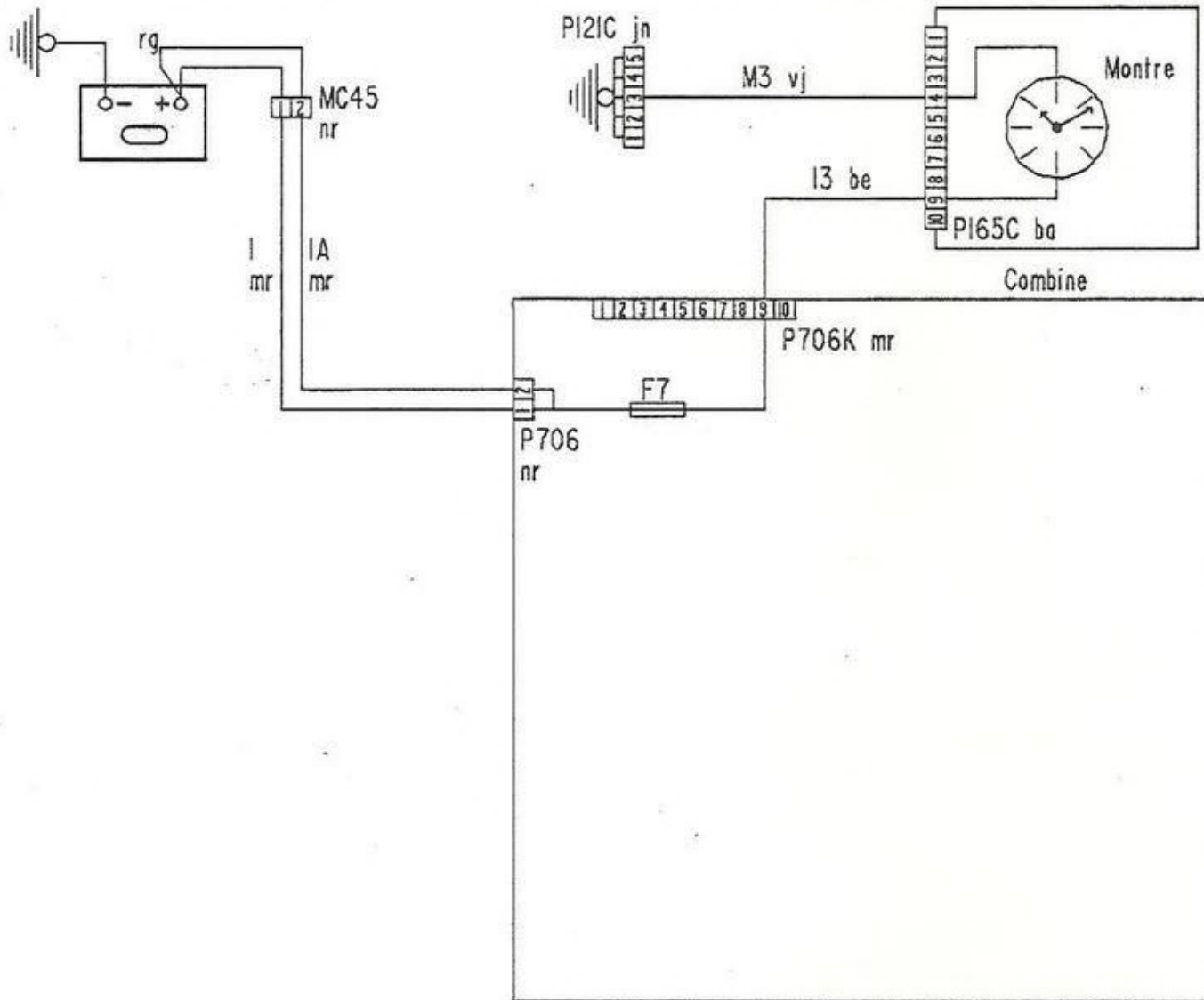

TYPES CONCERNES:
 -205ESS
 -205DSL
 -205GTI

MONTRE DIGITALE ECLAIR. VIDE POCHE

24
 1

A JOUR LE: 20-06-85

NOM: VIGNES

TEL: 3162

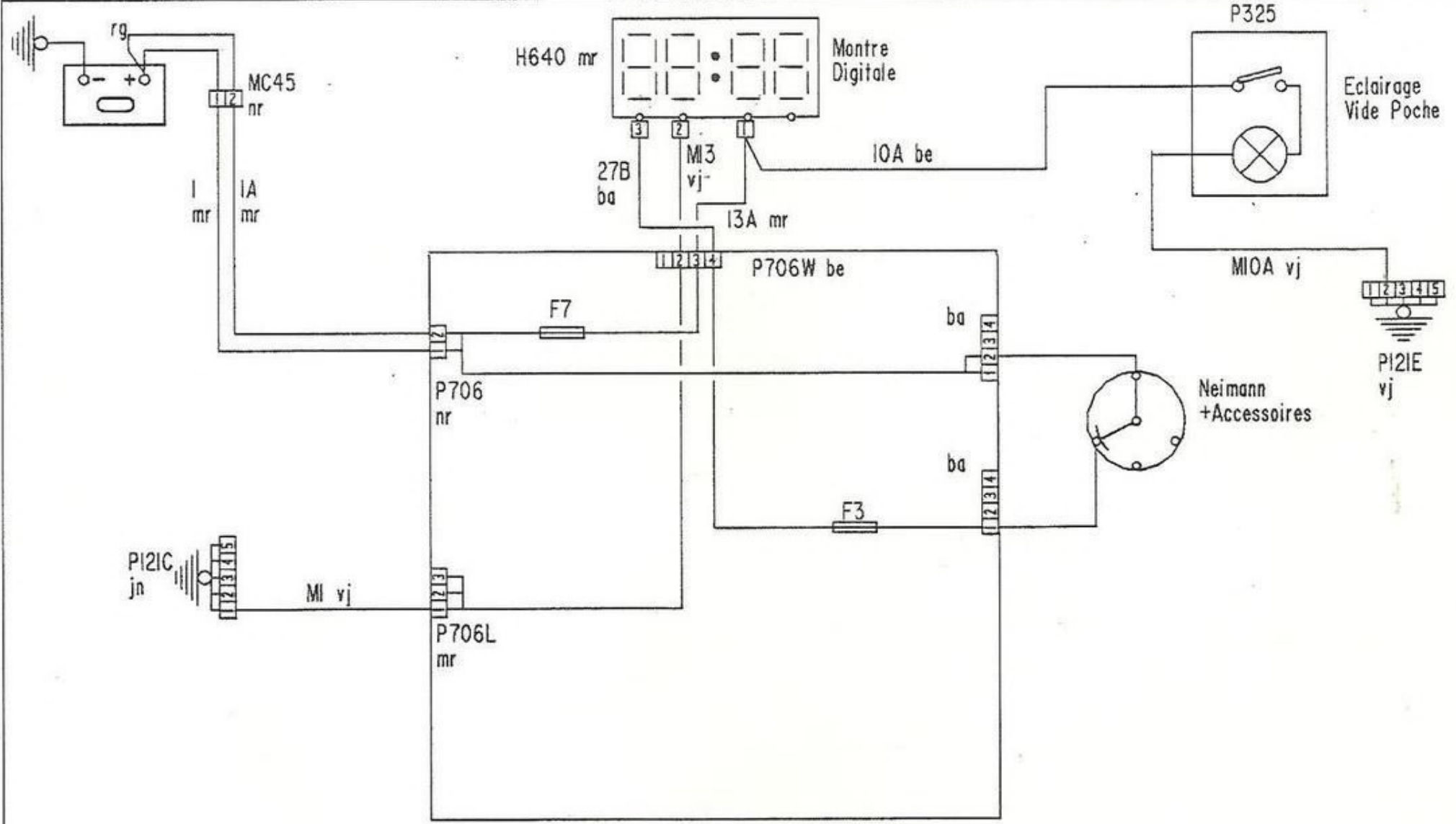

TYPES CONCERNES:
-205ESS
-205DSL
-205GTI

CLIMATISEUR

25
1

A JOUR LE: 20-06-85

NOM: VIGNES

TEL: 3162

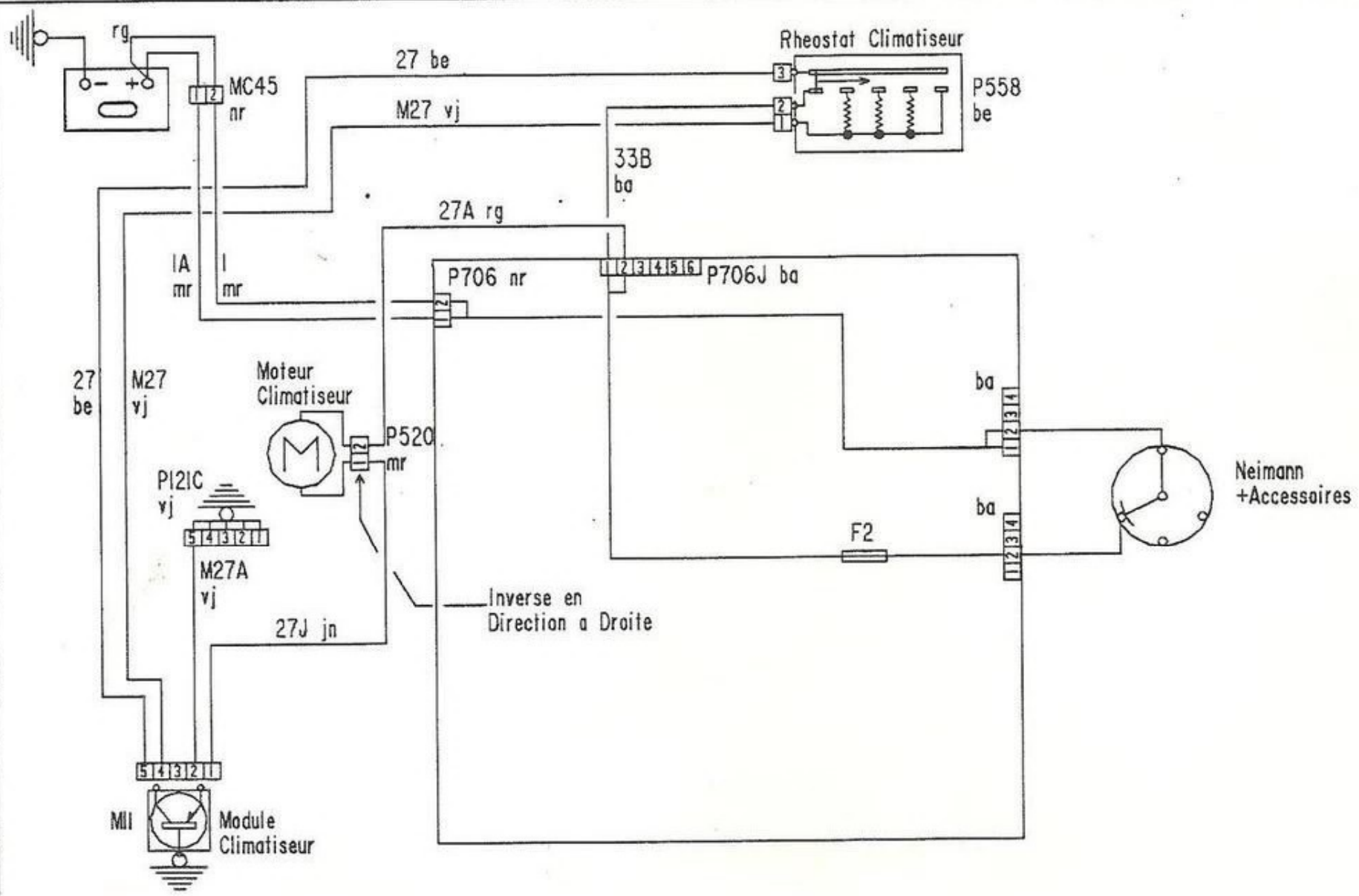

TYPES CONCERNES:
-205ESS
-205DSL
-205GTI

ALLUME CIGARE

26
1

A JOUR LE: 20-06-85

NOM: VIGNES

TEL: 3162

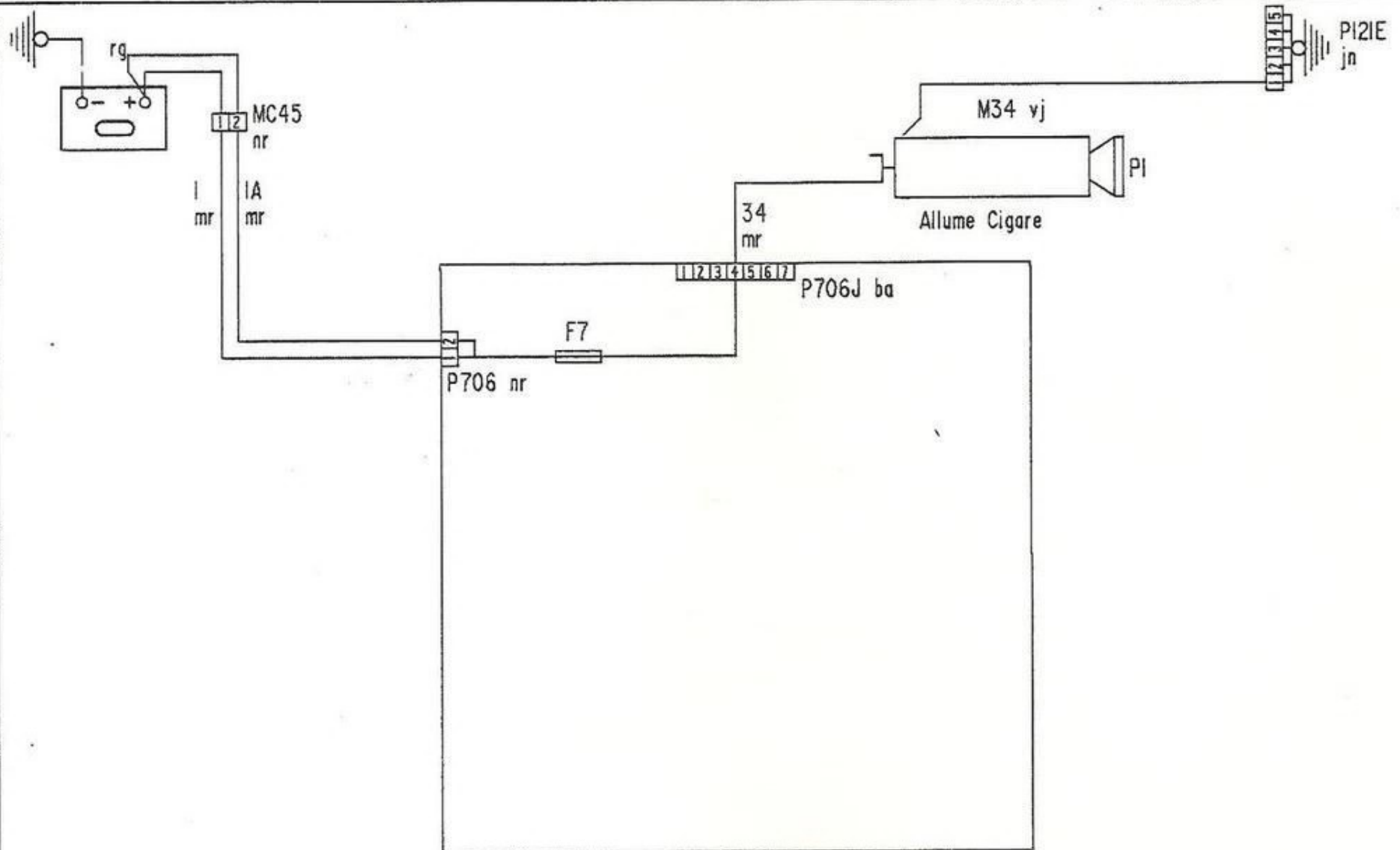

TYPES CONCERNES:
-205ESS
-205DSL

TEMOIN FREIN A MAIN

27
1

A JOUR LE: 20-06-85

NOM: VIGNES

TEL: 3162

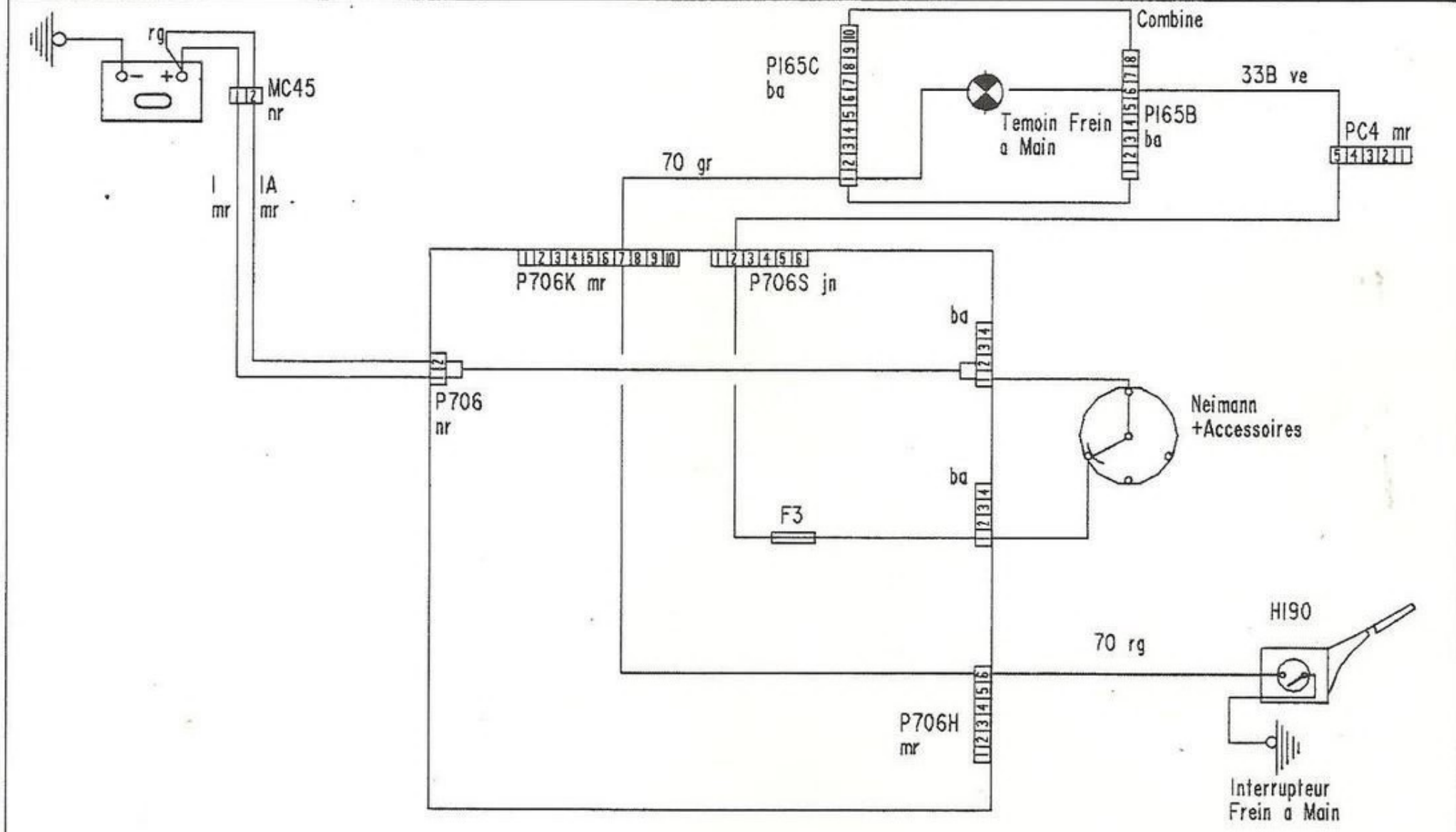

TYPE CONCERNE:
-205GTI

TEMOIN FREIN A MAIN NIVEAU LIQUIDE FREIN

27
2

A JOUR LE: 20-06-85

NOM: VIGNES

TEL: 3162

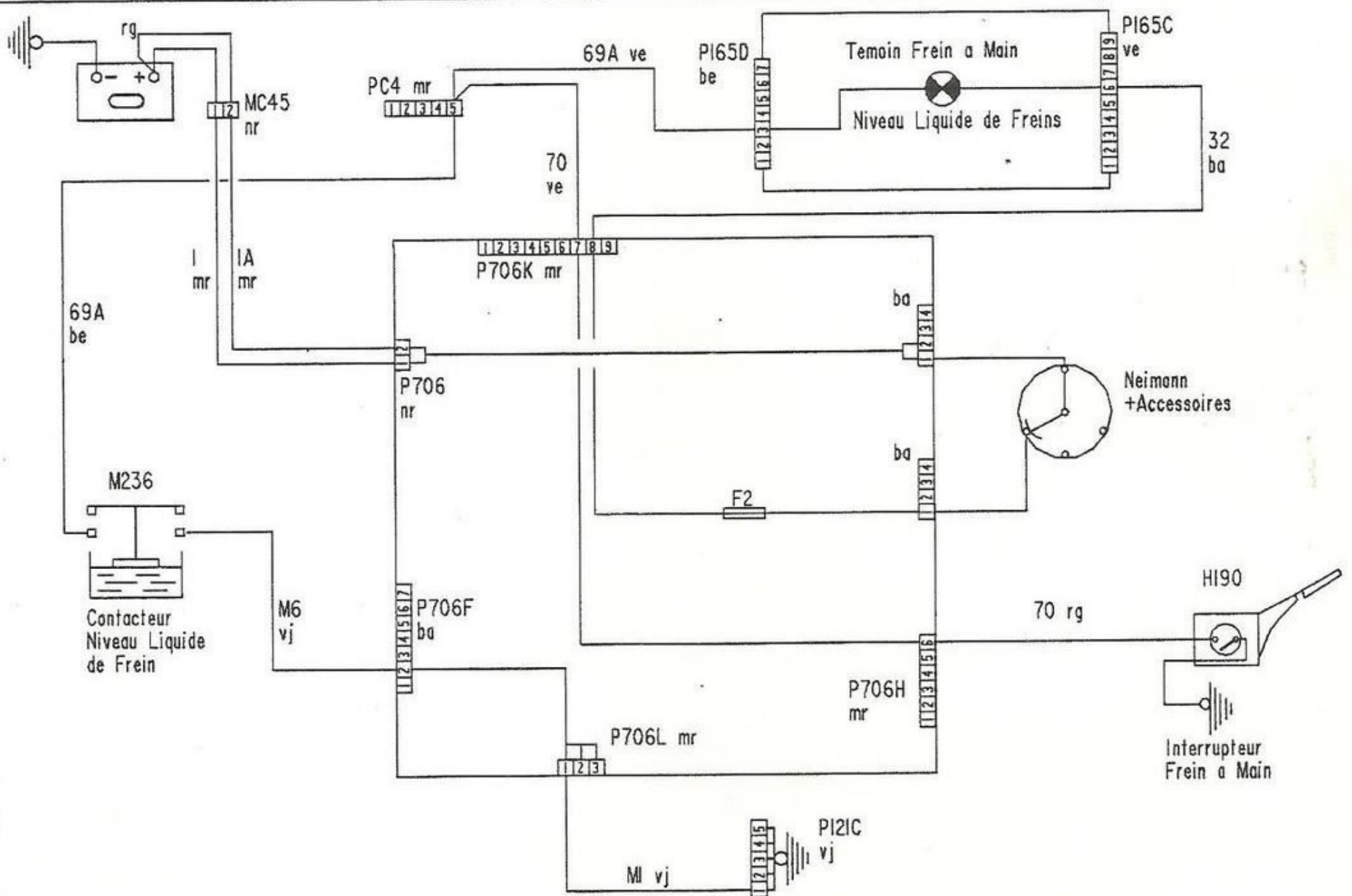

ALIMENTATION AUTO-RADIO: TOUS TYPES
 ALIMENTATION HAUT PARLEURS AVANT: TOUS TYPES SAUF L, GL
 ALIMENTATION HAUT PARLEURS ARRIERE: SUR GH1600 SEULEMENT

TYPES CONCERNES:
 -205ESS
 -205DSL
 -205GT1

ALIMENT. AUTO RADIO
 HAUT PARLEURS

28
 1

A JOUR LE: 20-06-85

NOM: VIGNES

TEL: 3162

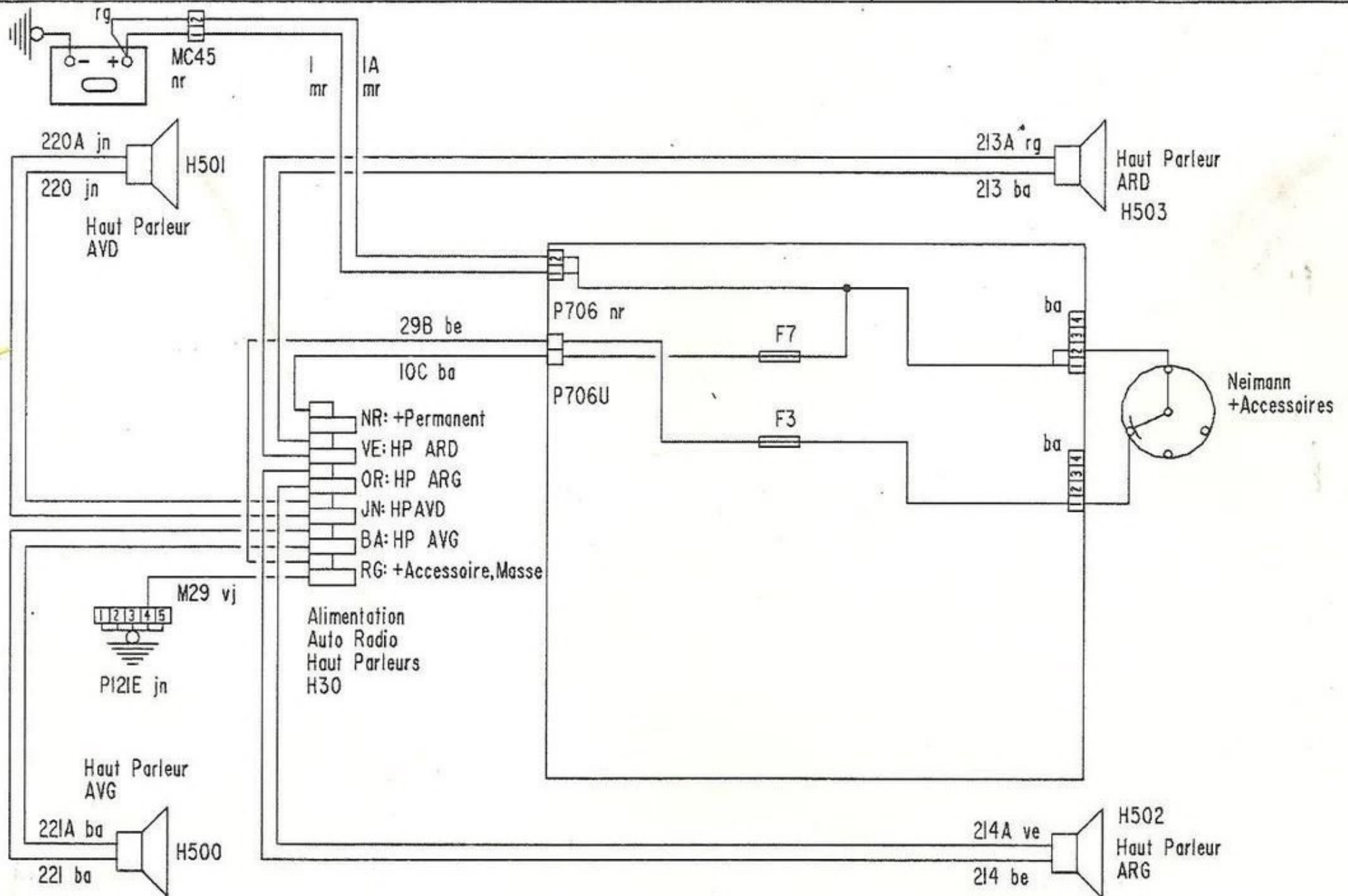

TYPES CONCERNES:
-205ESS
-205DSL
-205GTI

PLAFONNIER LECTEUR DE CARTES

29
1

A JOUR LE: 20-06-85

NOM: VIGNES

TEL: 3162

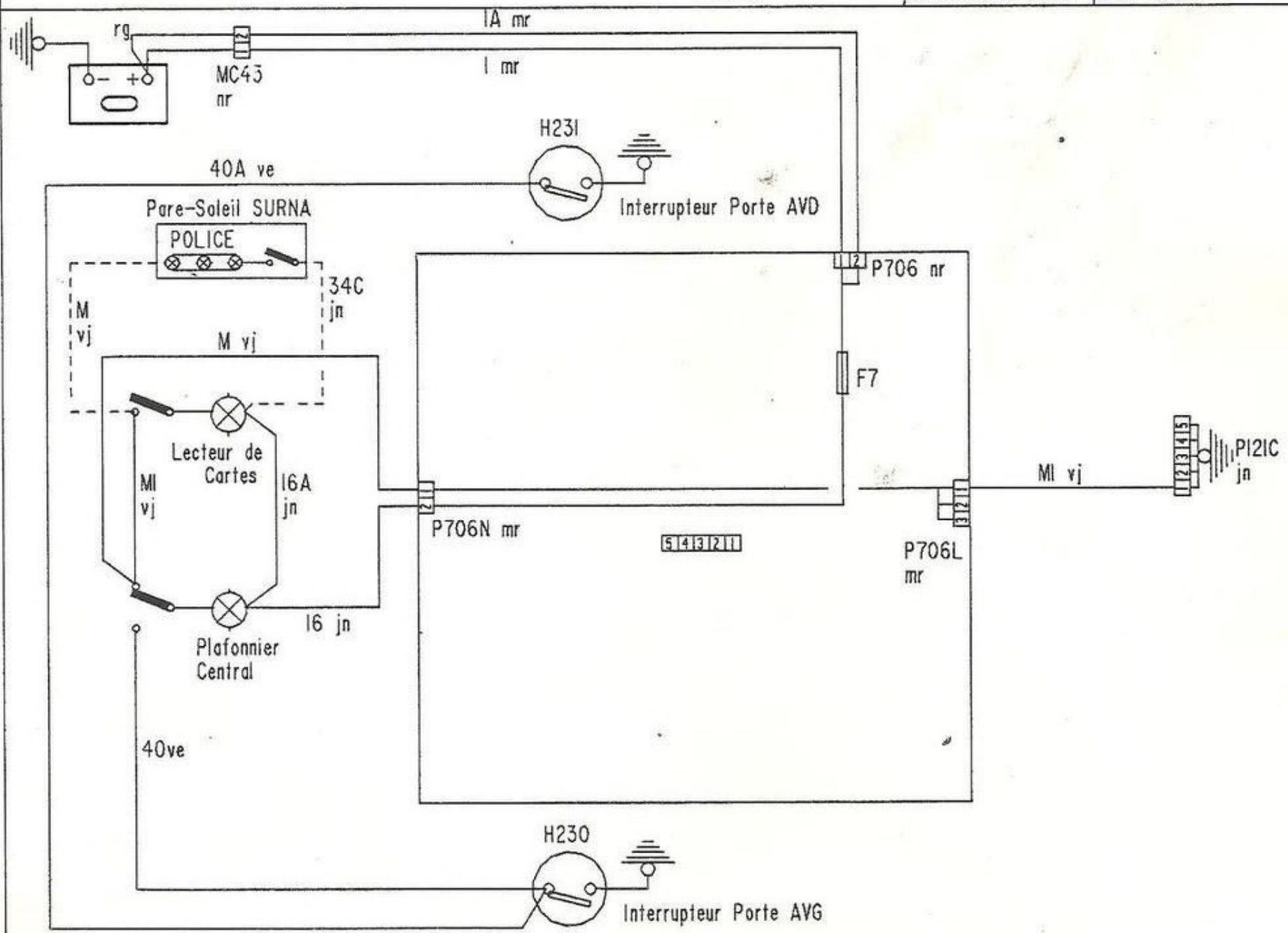

TYPES CONCERNES:
 -205ESS
 -205DSL
 -205GTI

LEVE VITRES ELECTRIQUES

30

A JOUR LE: 20-06-85

NOM: VIGNES

TEL: 3162

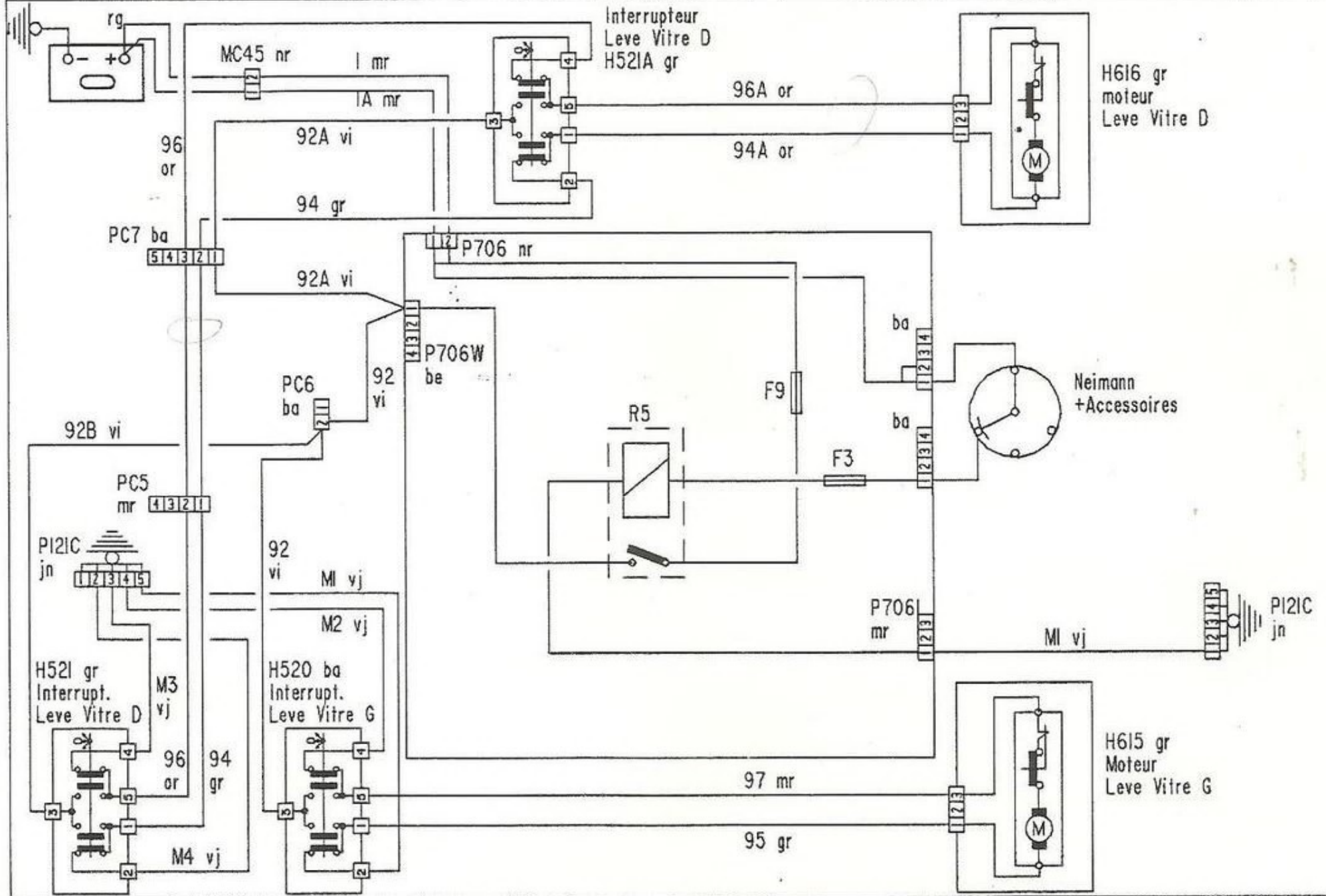

TYPES CONCERNES:
-205ESS
-205DSL

CONDAMNATION
CENTRALISE

31
1

A JOUR LE: 20-06-85

NOM: VIGNES

TEL: 3162

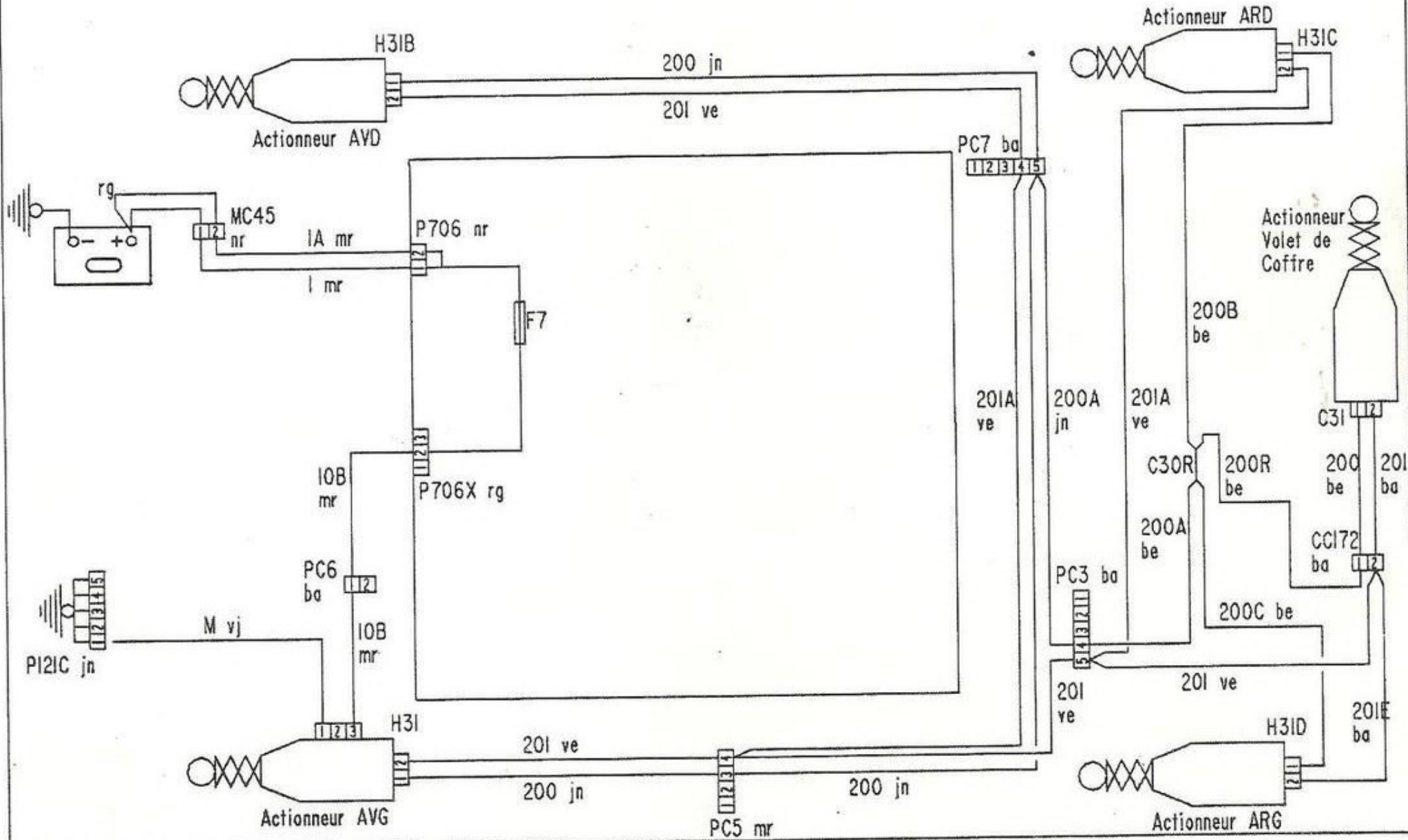

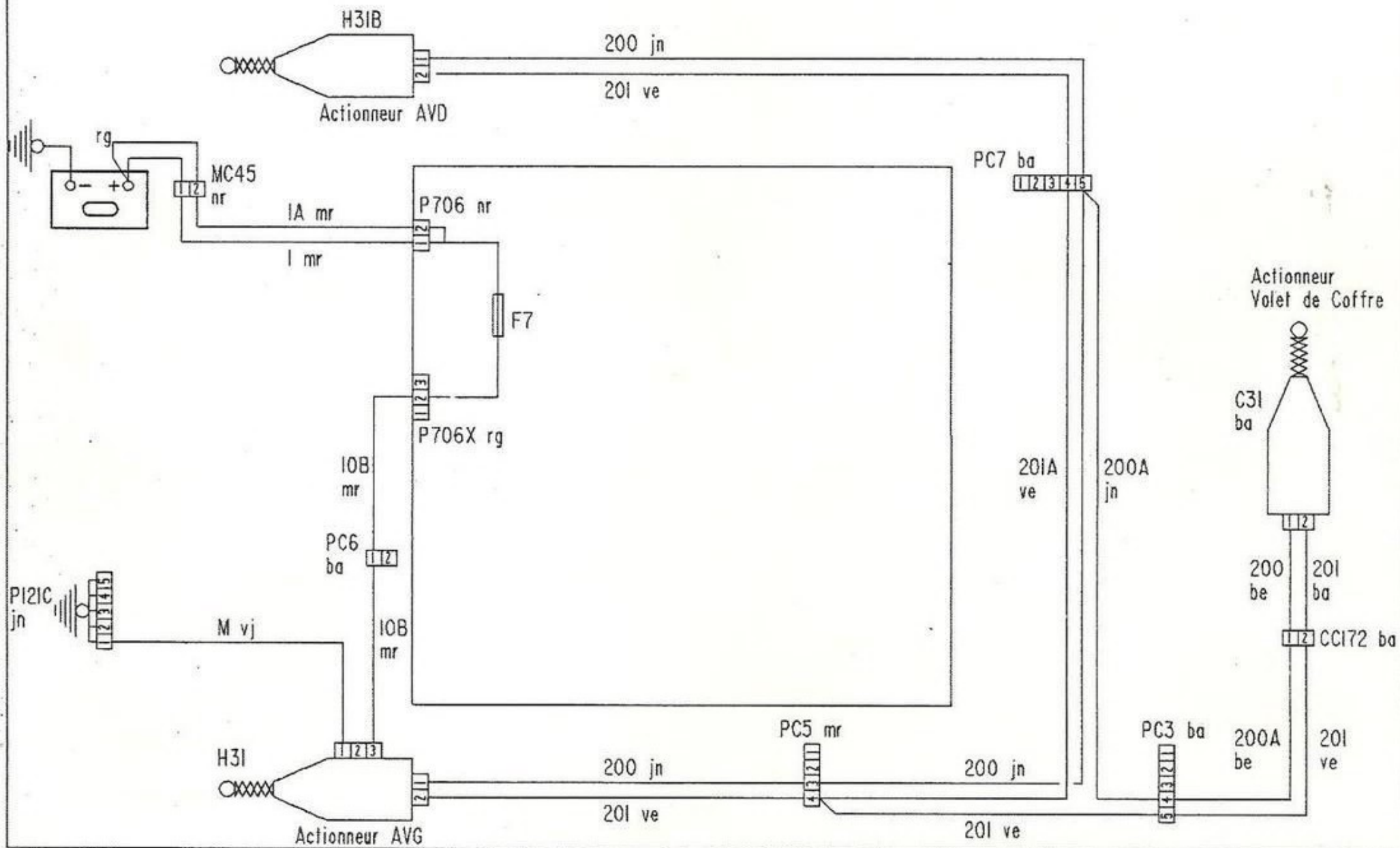

TYPES CONCERNES:
 -205ESS
 -205DSL
 -205GT1

FEUX STOP

32
 1

A JOUR LE: 20-06-85

NOM: VIGNES

TEL: 3162

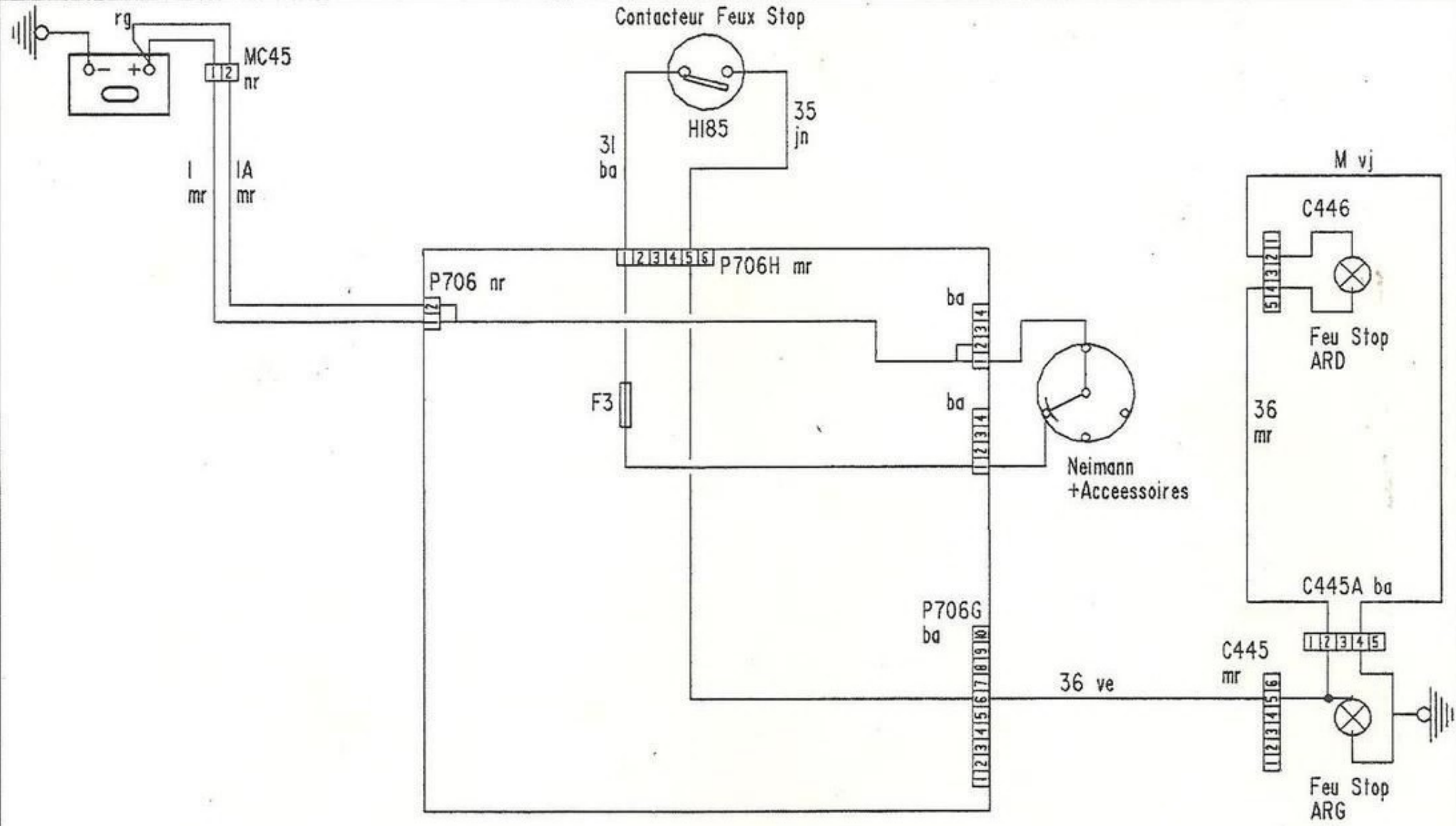

TYPES CONCERNES:
-205ESS
-205DSL
-205GTI

FEUX DE REcul

33
1

A JOUR LE: 20-06-85

NOM: VIGNES

TEL: 3162

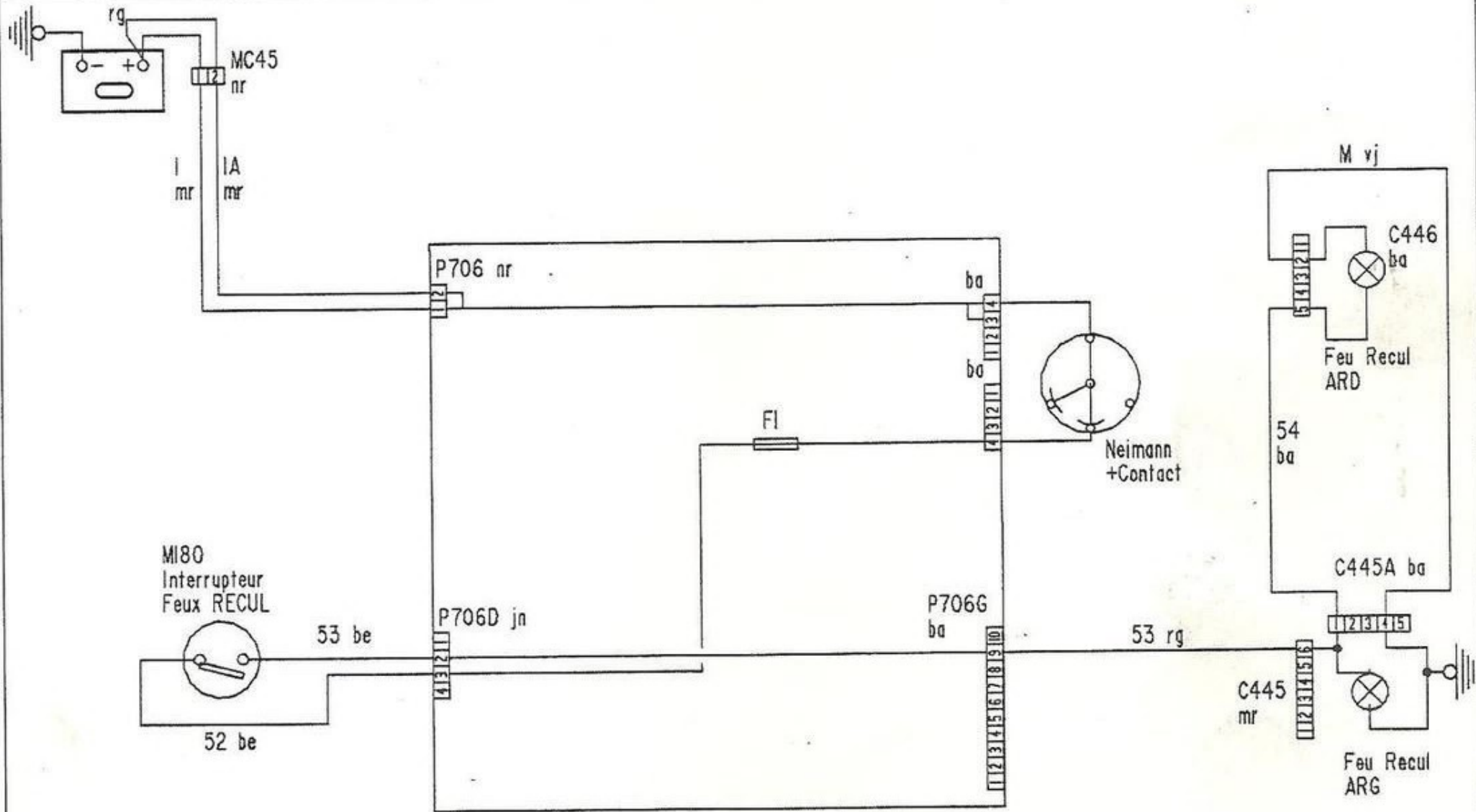

TYPES CONCERNES:
-205ESS
-205DSL
-205GTI

FEU ARRIERE BROUILL. 34
(SAUF GHI 141)

A JOUR LE: 20-06-85

NOM: VIGNES

TEL: 3162

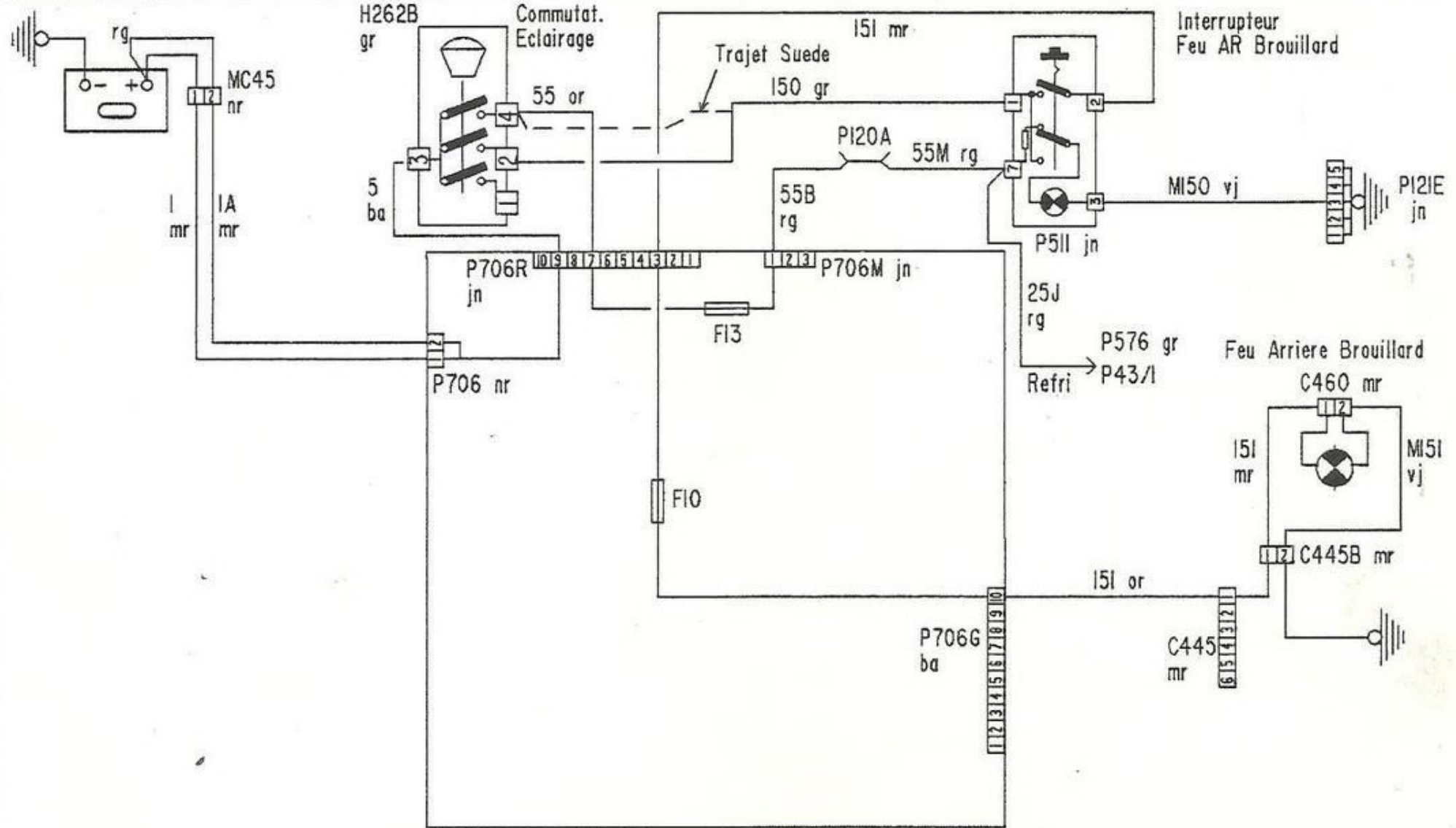

TYPES CONCERNES:
 -205ESS
 -205DSL
 -205GTI

ECLAIREURS PLAQUE POLICE

35
 1

A JOUR LE: 20-06-85

NOM: VIGNES

TEL: 3162

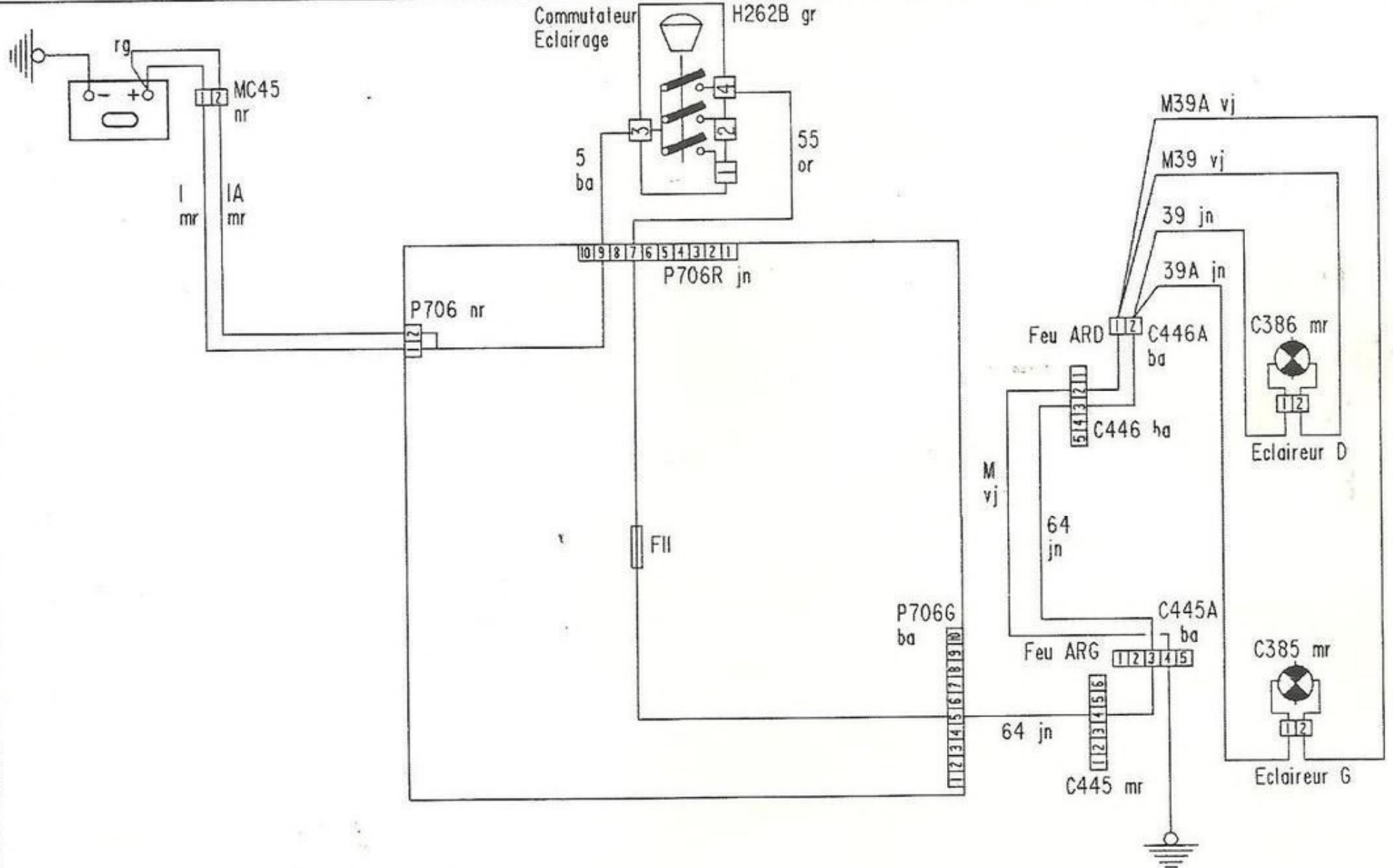

TYPES CONCERNES:
-205ESS
-205DSL

JAUGE CARBURANT

36/1

A JOUR LE: 20-06-85

NOM: VIGNES

TEL: 3162

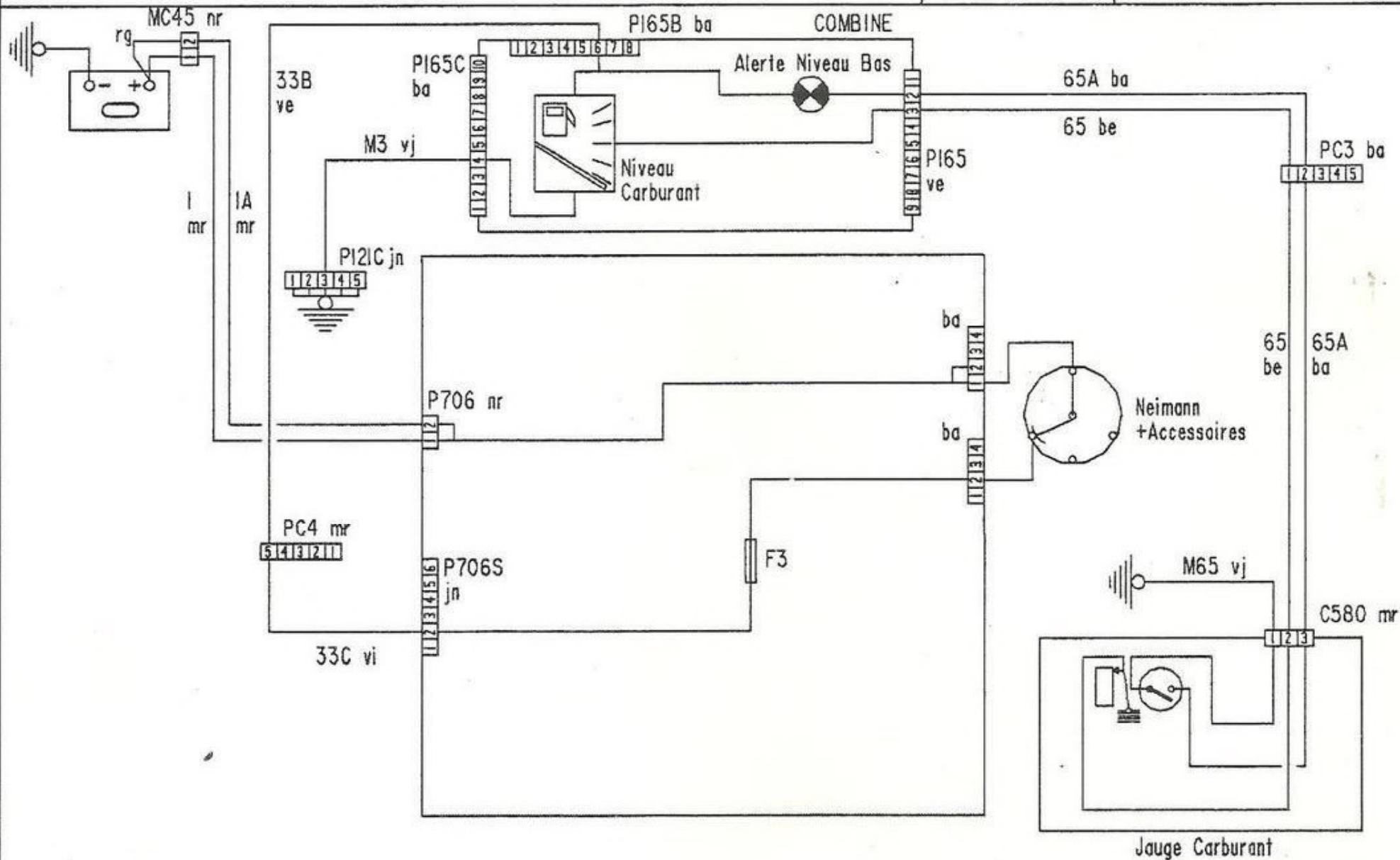

TYPE CONCERNE:
-205GTI

JAUGE CARBURANT

36
2

A JOUR LE: 20-06-85

NOM: VIGNES

TEL: 3162

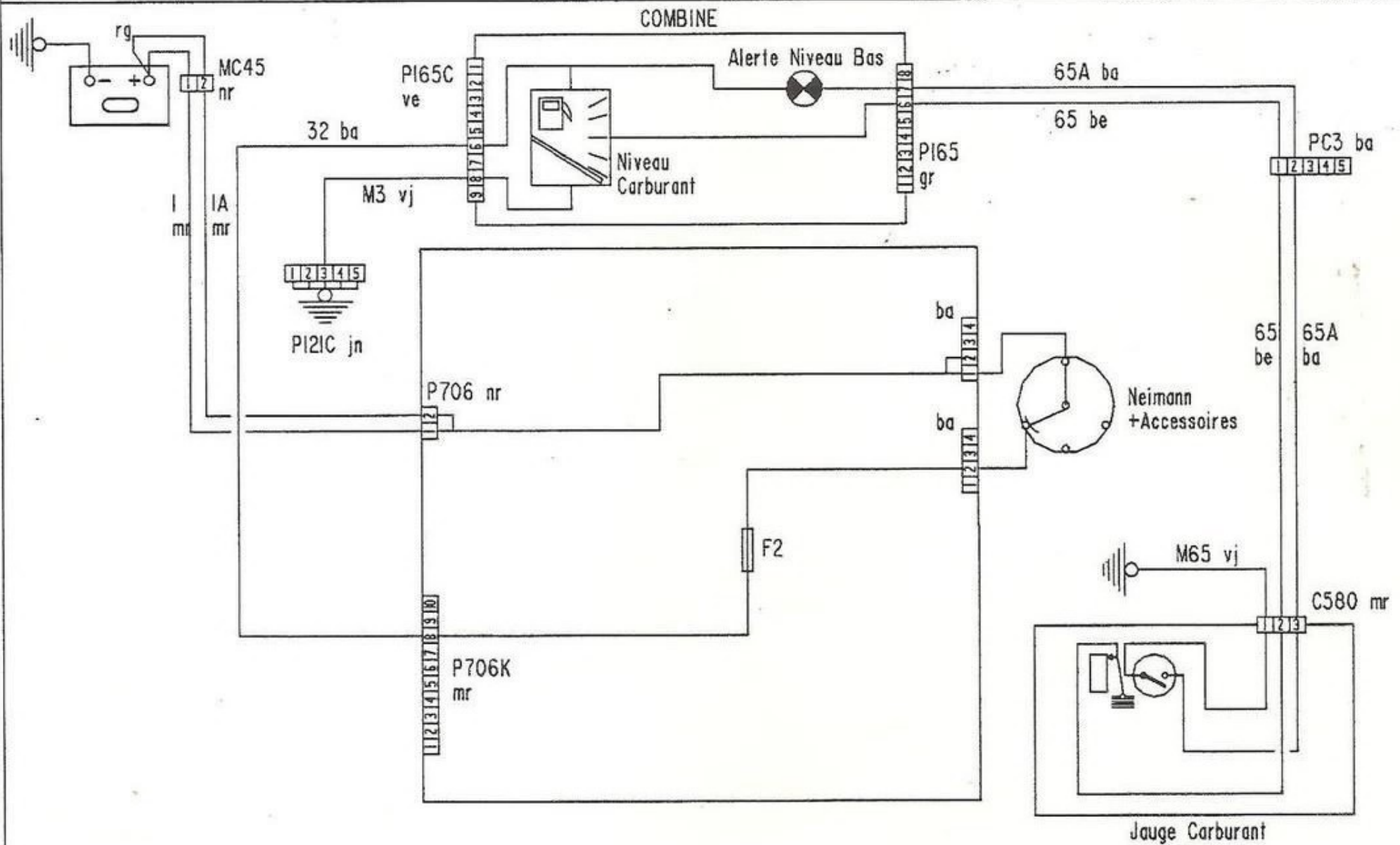

TYPES CONCERNES:
 -205ESS
 -205DSL
 -205GT1

LUNETTE CHAUFFANTE

37
1

A JOUR LE: 20-06-85

NOM: VIGNES

TEL: 3162

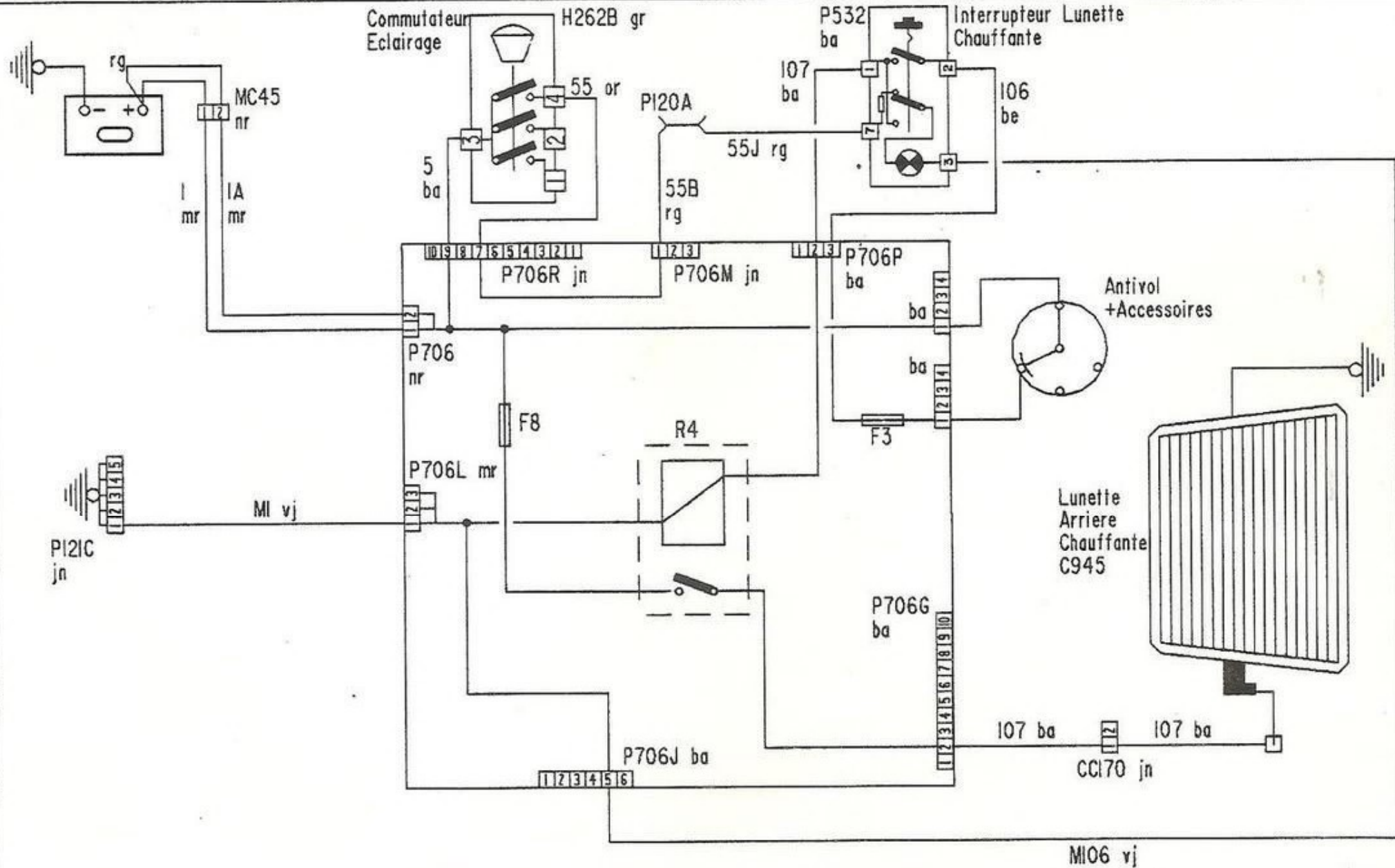

Le connecteur CCI71
deviendra Rouge et
les cases 1 et 2 seront
inversees ulterieurement

-33A en Pointilles:
Trajet GTI uniquement

-33M,61A en Pointilles:
EV AV avec Intermittence
uniquement

TYPES CONCERNES:
-205ESS
-205DSL
-205GTI

ESSUIE VITRE ARRIERE

38
1

A JOUR LE: 20-06-85

NOM: VIGNES

TEL: 3162

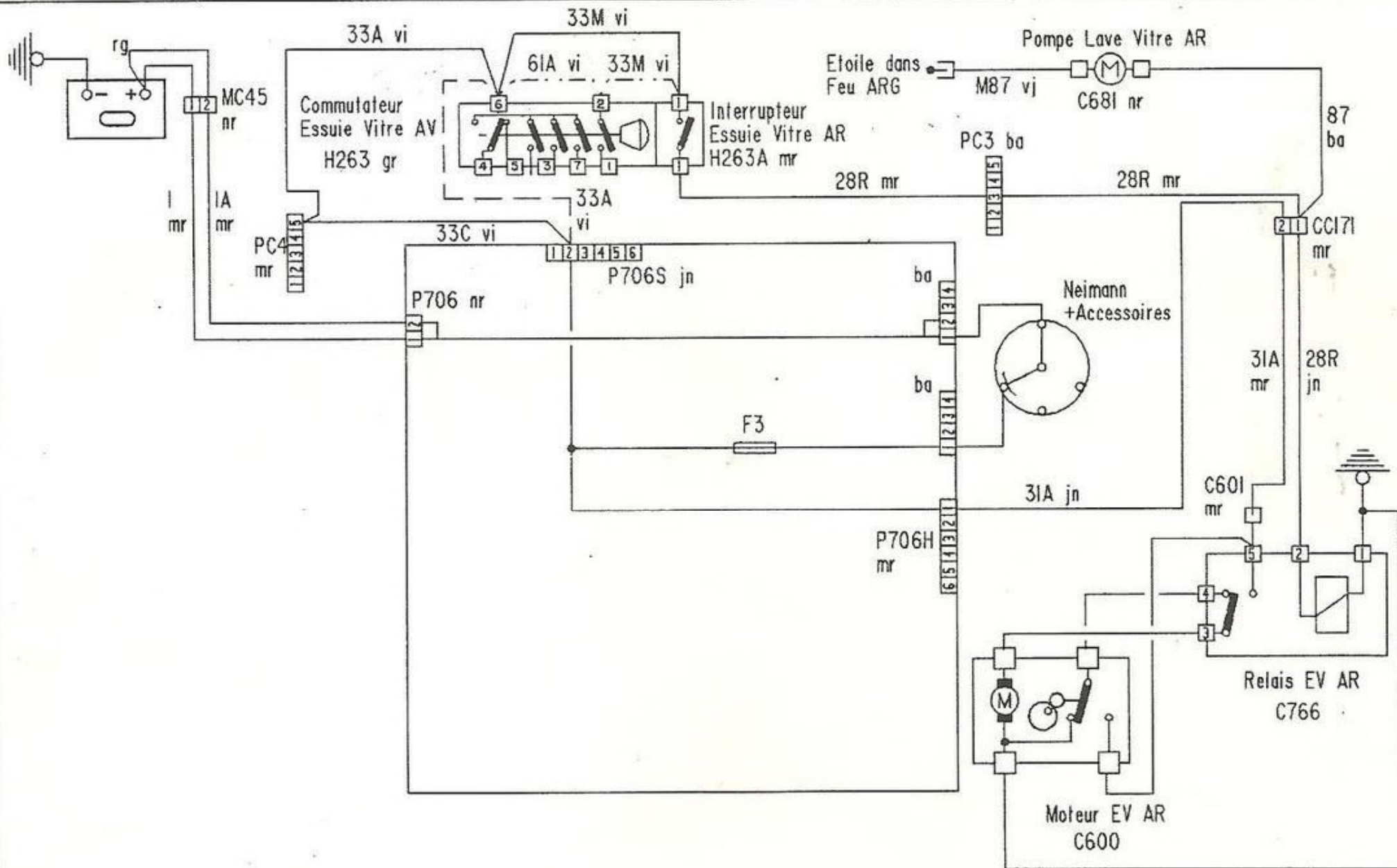

TYPES CONCERNES:
-205ESS
-205DSL
-205GT

ALIMENTATION ATTACHE REMORQUE

39

A JOUR LE: 20-06-85

NOM: VIGNES

TEL: 3162

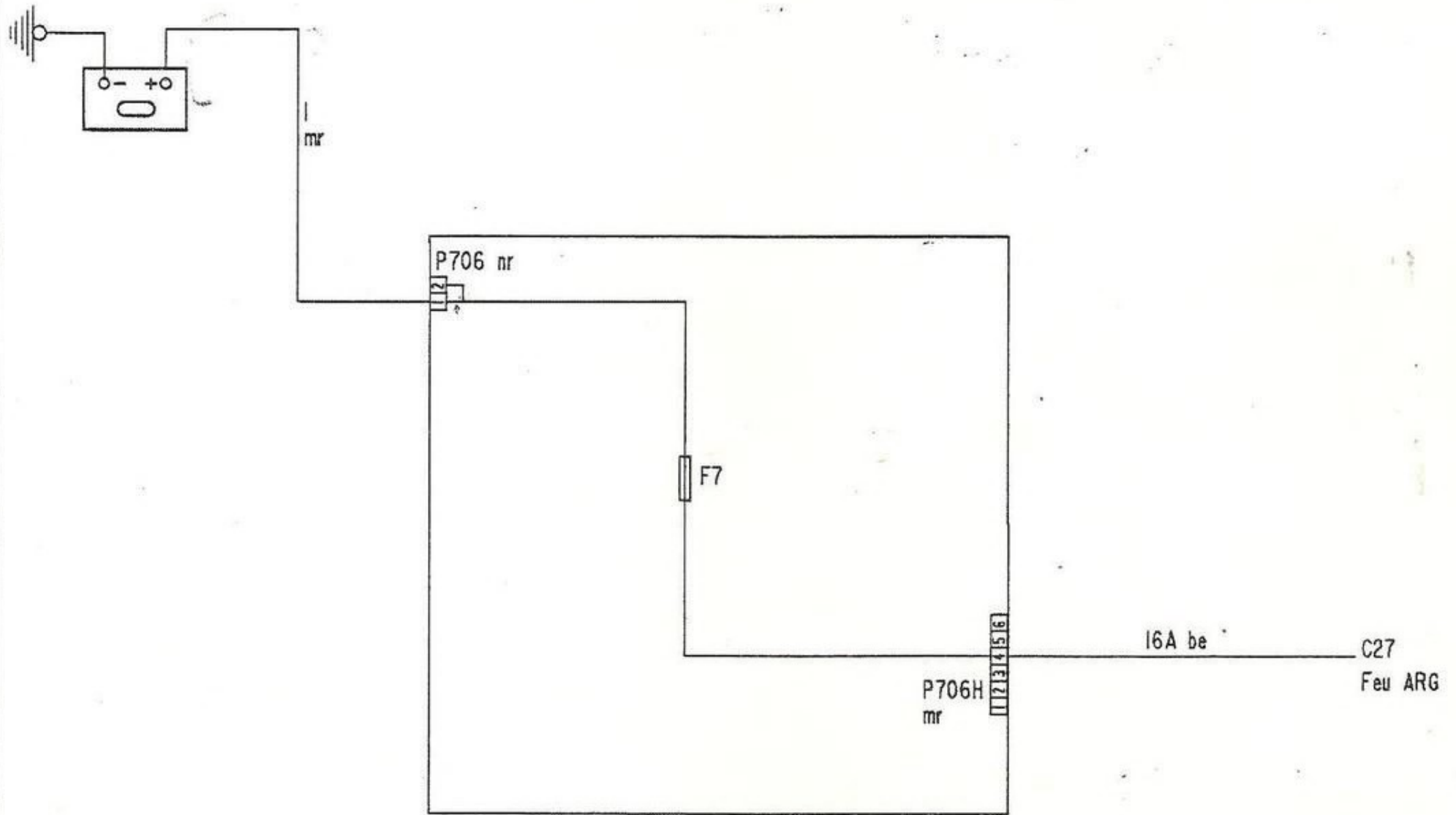

ECLAIREUR COFFRE

39
2

A JOUR LE: 20-06-85

NOM: VIGNES

TEL: 3162

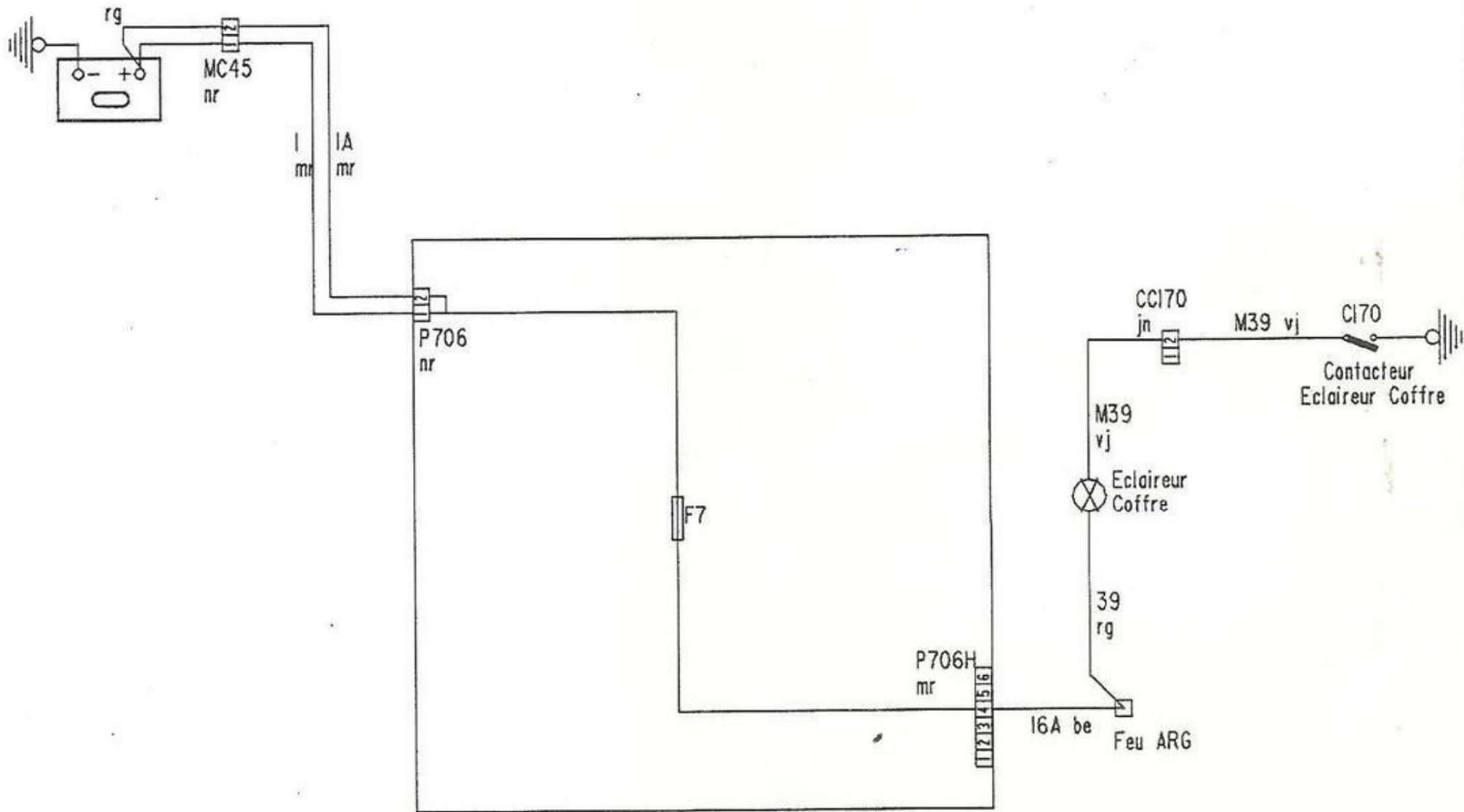

TYPES CONCERNES:
 -205ESS
 -205DSL
 -205GT1

LAVE PROJECTEURS

40

A JOUR LE: 20-06-85

NOM: VIGNES

TEL: 3162

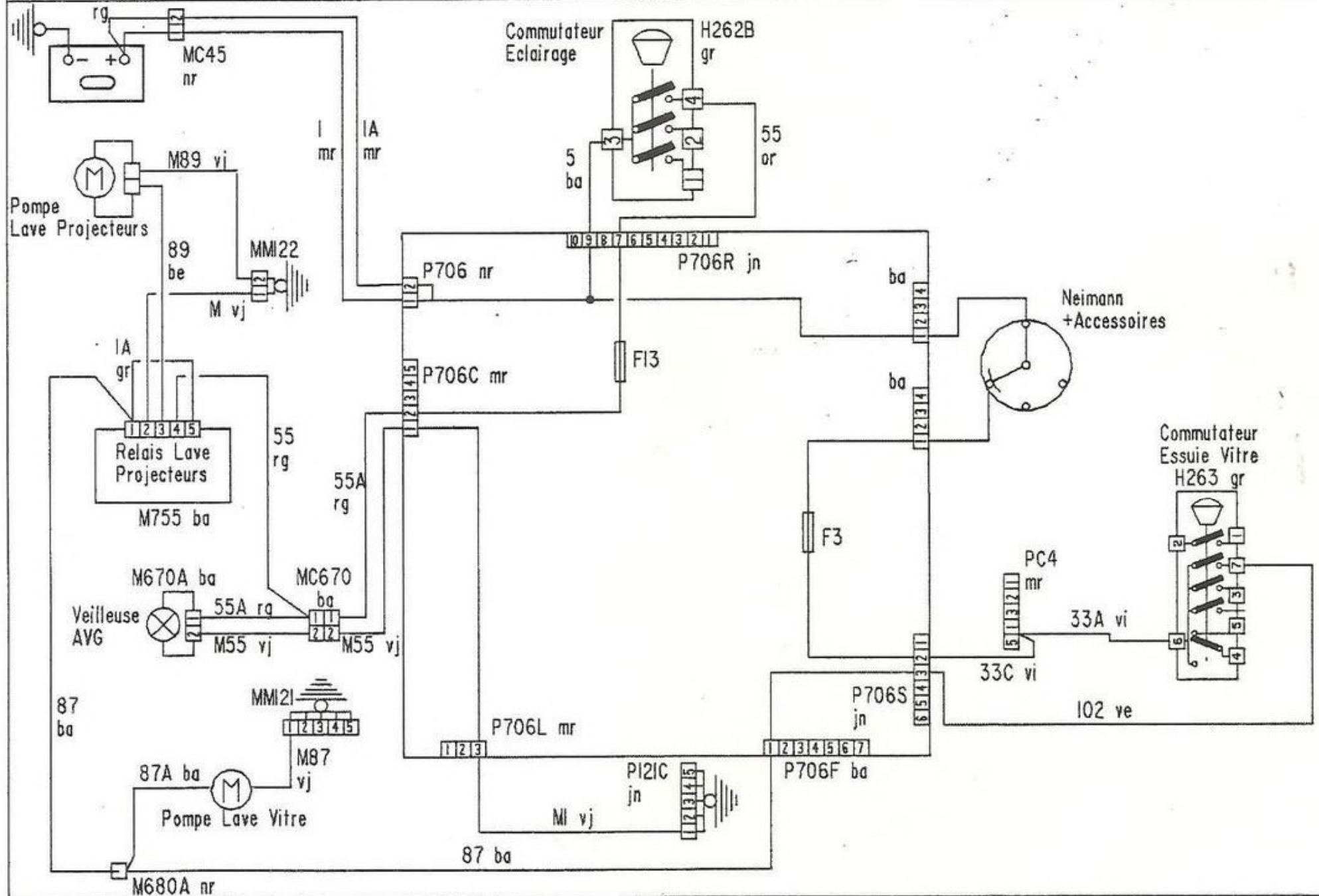



TYPES CONCERNES:
 -205ESS
 -205DSL
 -205GTI

SIEGES CHAUFFANTS

41

A JOUR LE: 20-06-85

NOM: VIGNES

TEL: 3162

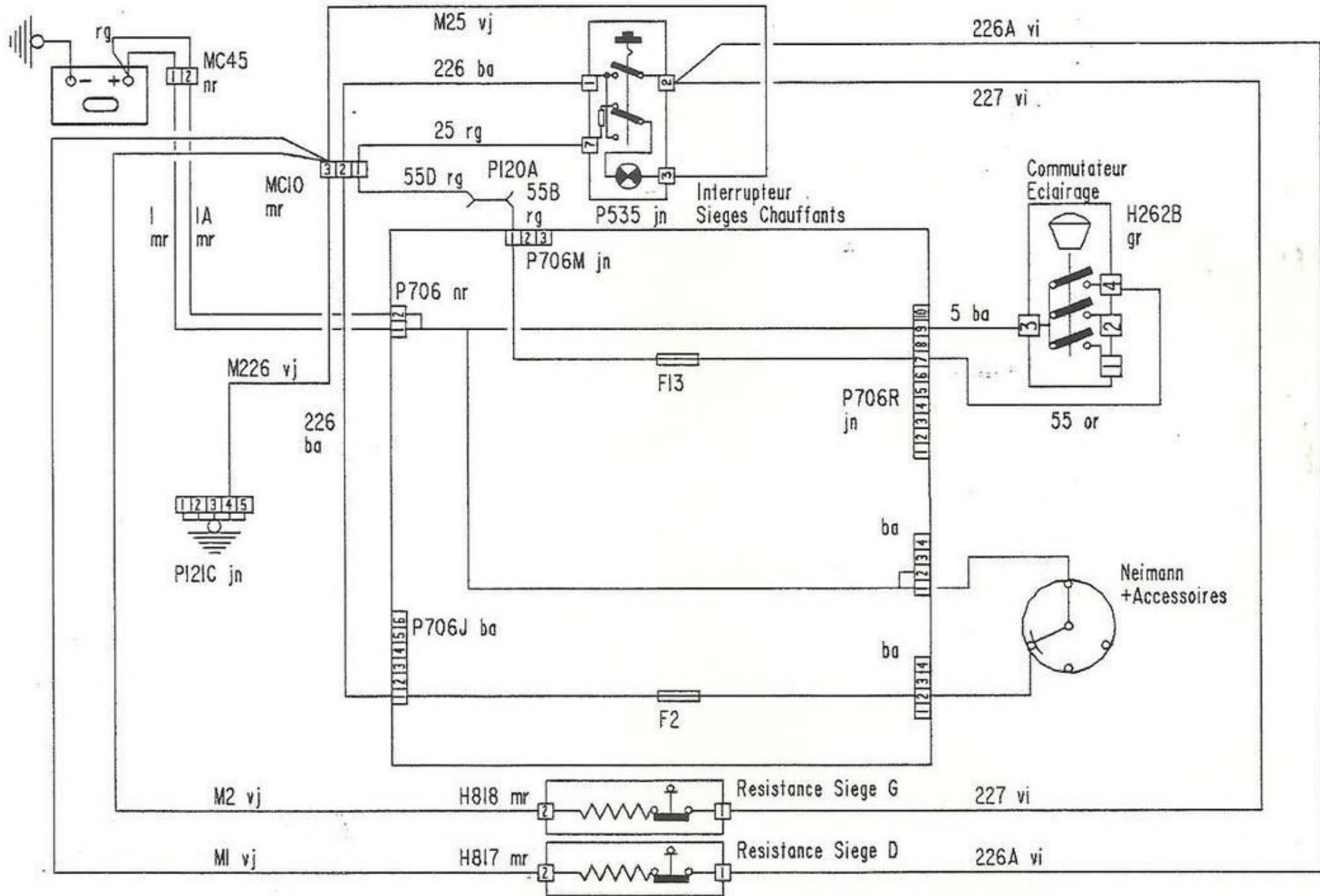

TYPES CONCERNES:
-205 ESSENCE
-205GTI

FEUX DIURNES GHI 14X

42

A JOUR LE: 20-06-85

NOM: VIGNES

TEL: 3162

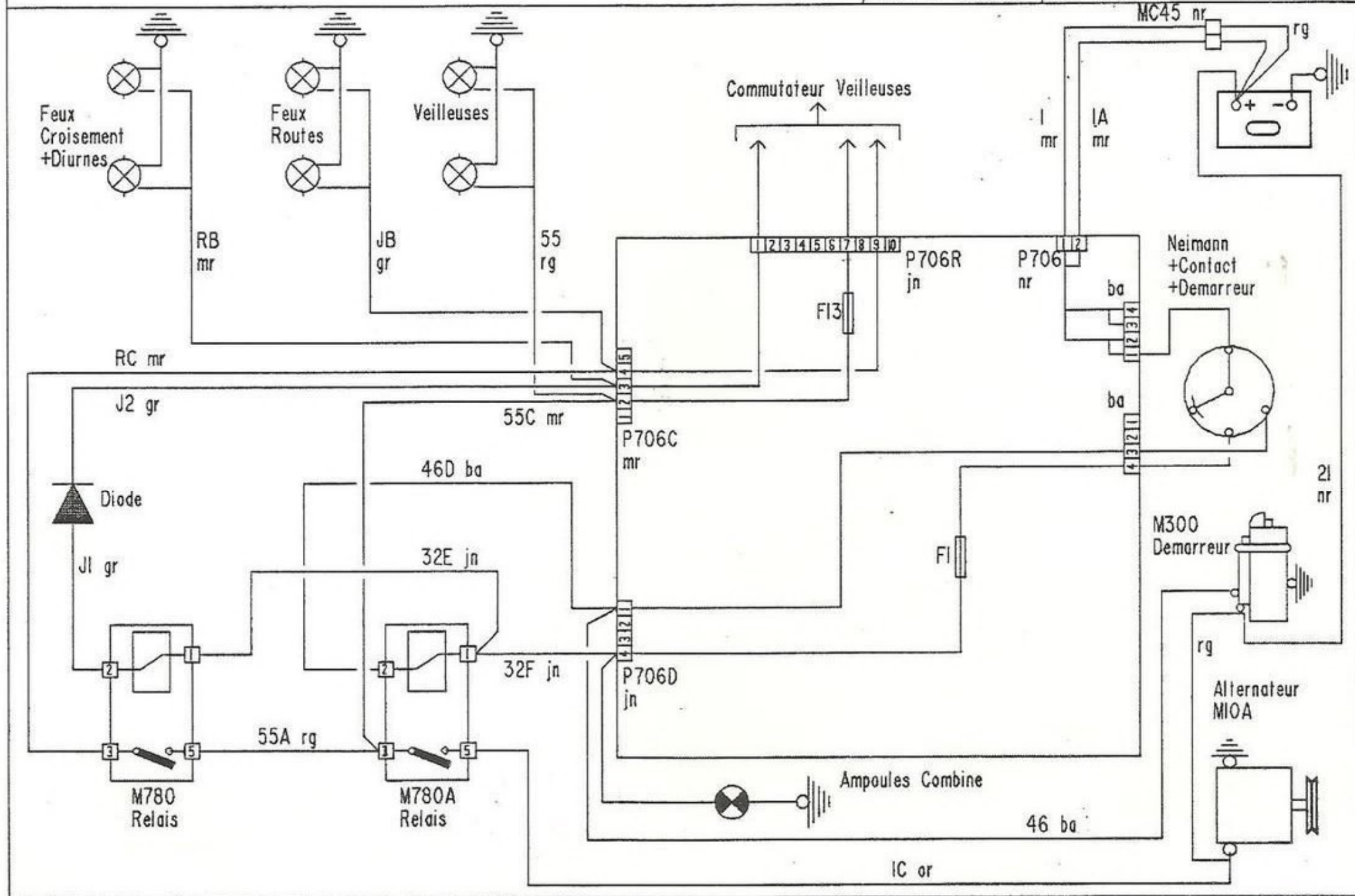

TYPE CONCERNE:
-205 DIESEL

FEUX DIURNES GHI 14X

42
2

A JOUR LE: 20-06-85

NOM: VIGNES

TEL: 3162

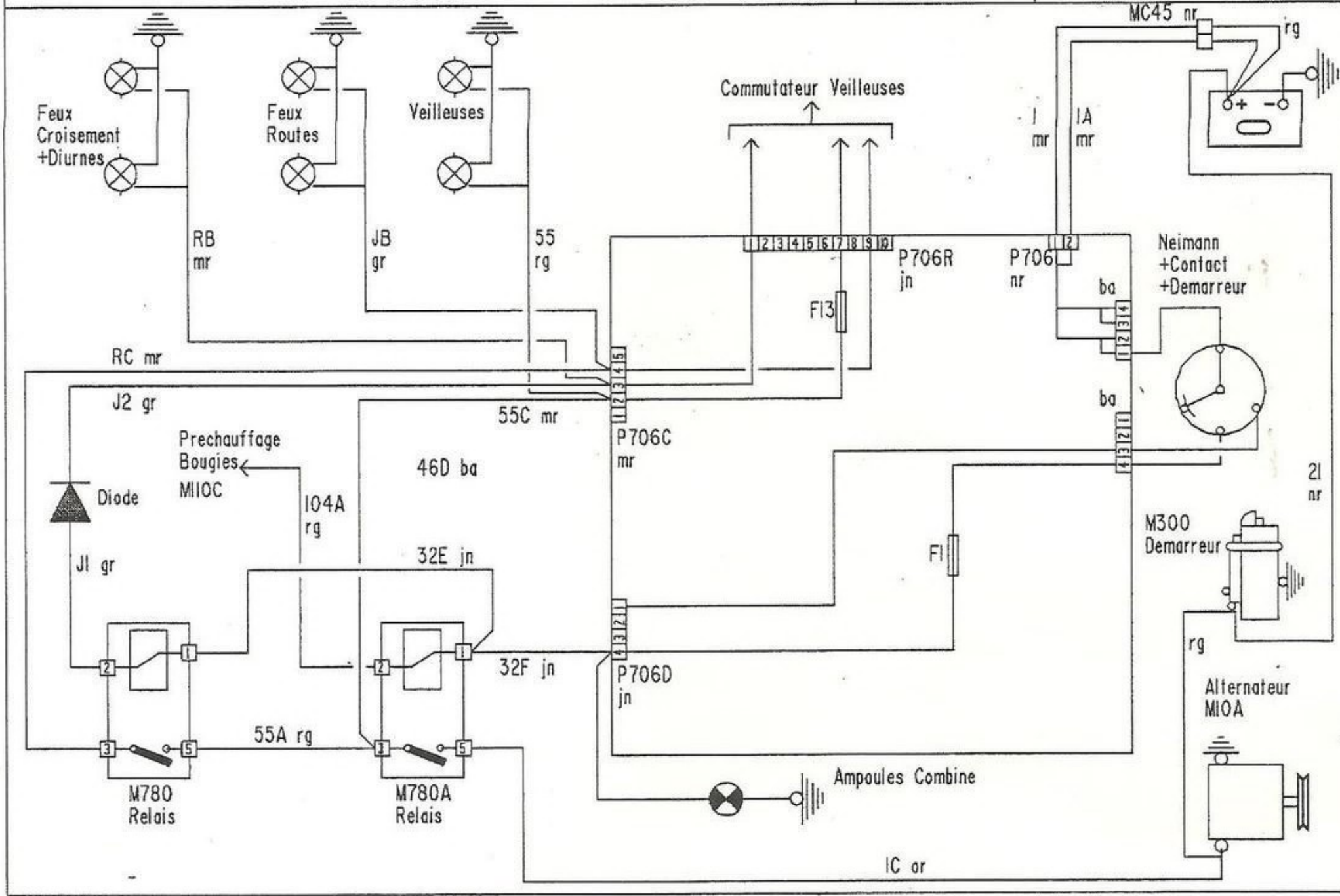

TYPES CONCERNES:
-205ESS
-205GT1

PARTICULARITE REFRIGERATION

43
1

A JOUR LE: 20-06-85

NOM: VIGNES

TEL: 3162

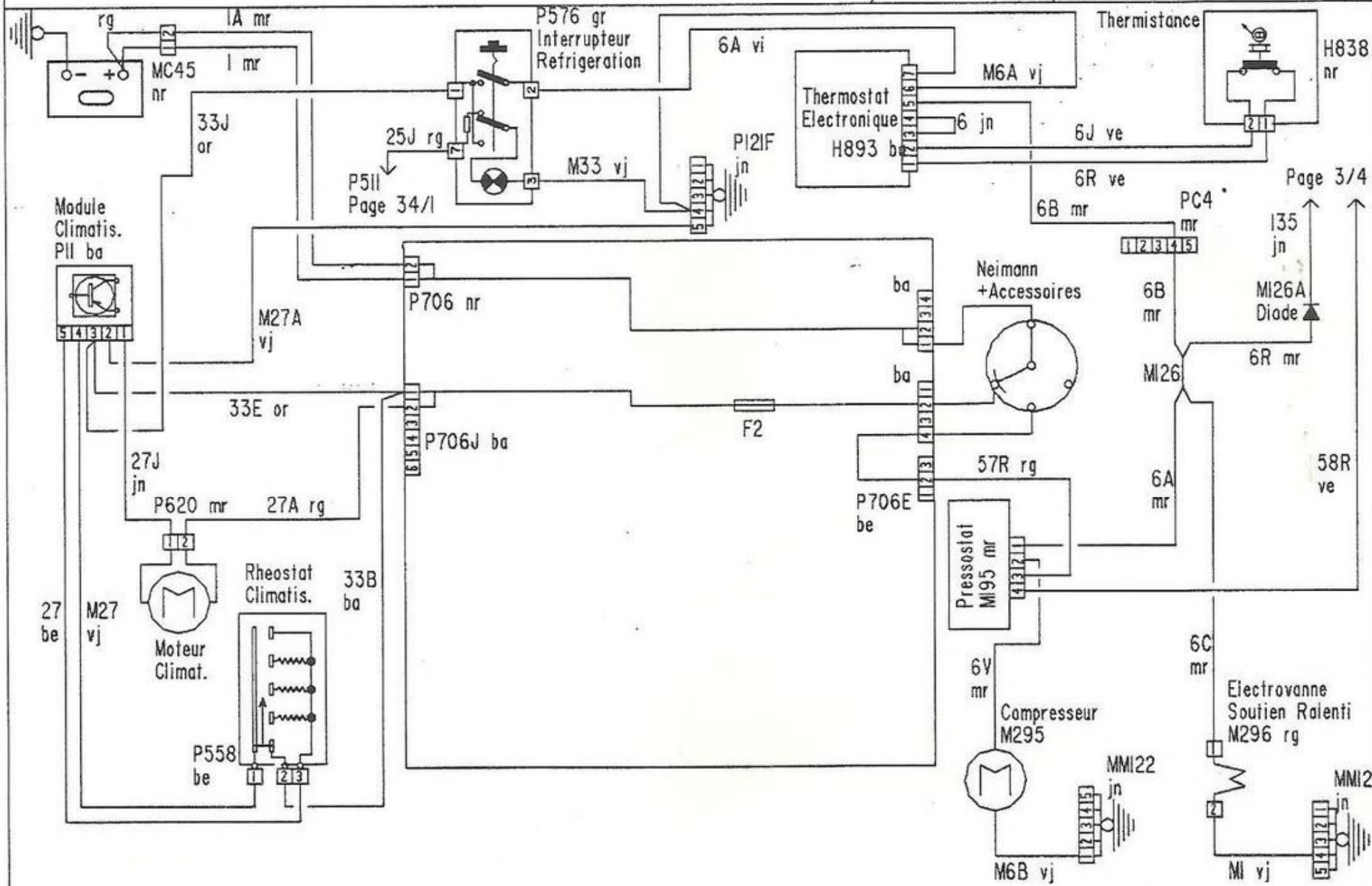

Page 3/4

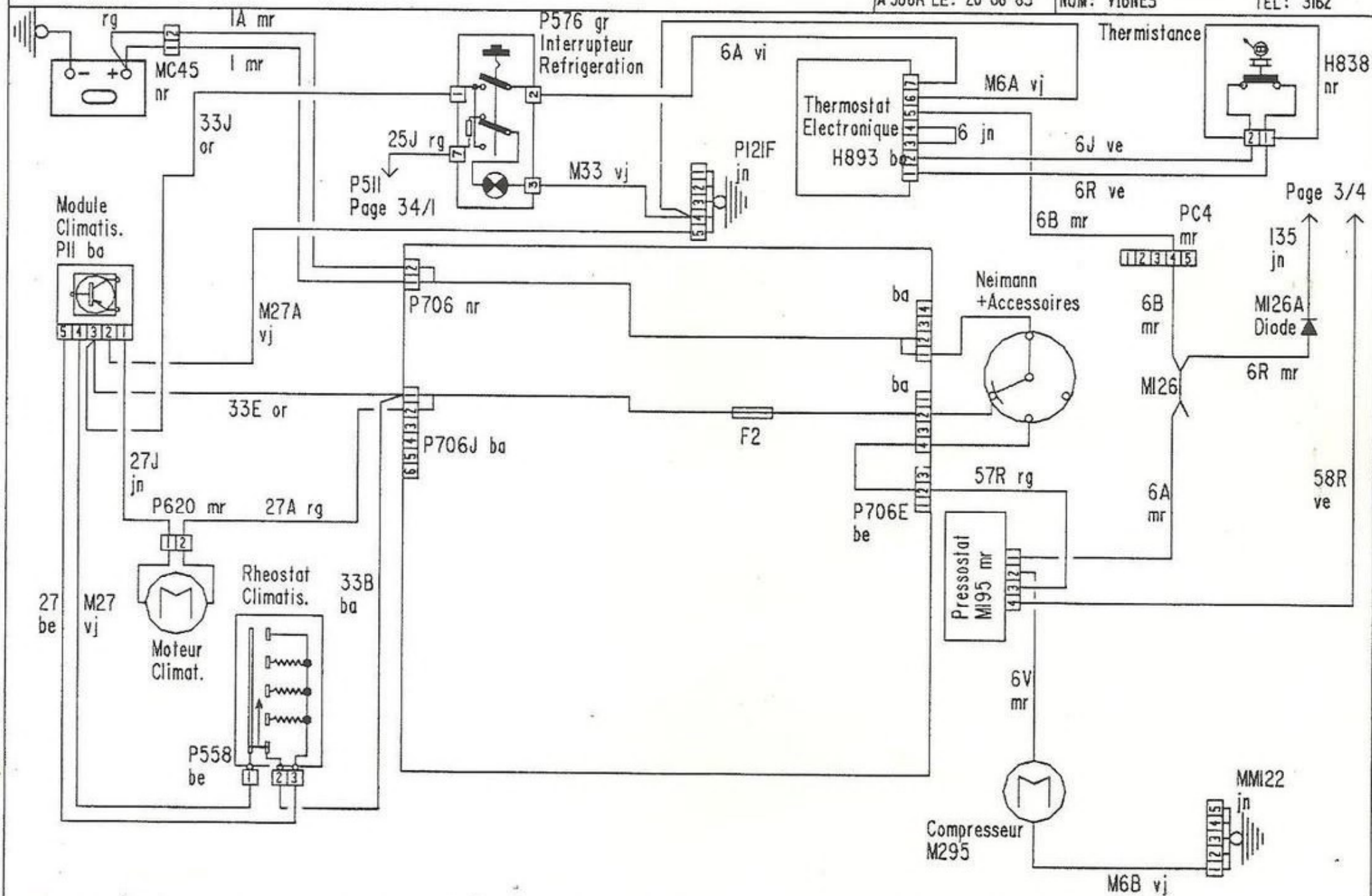

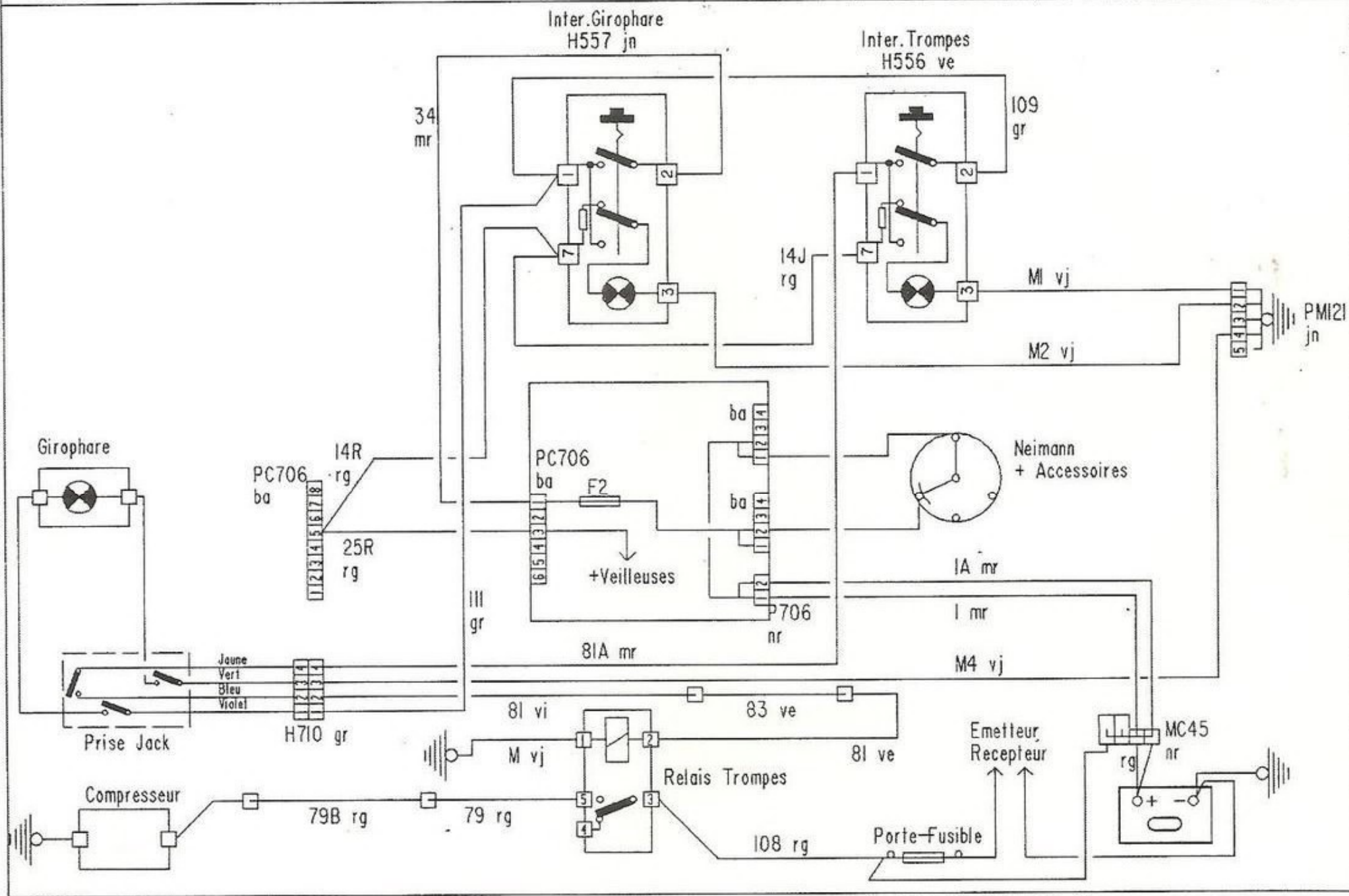

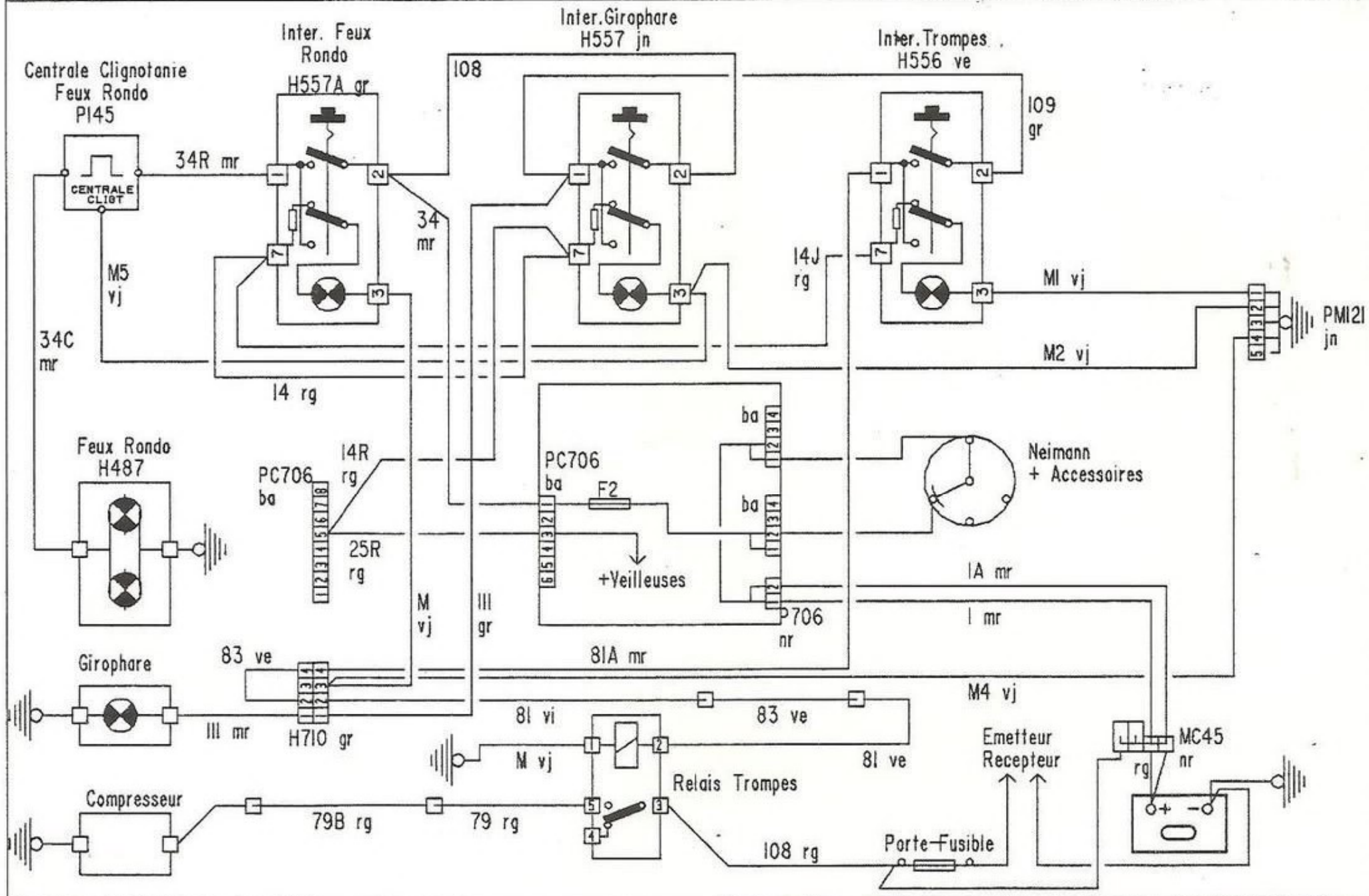

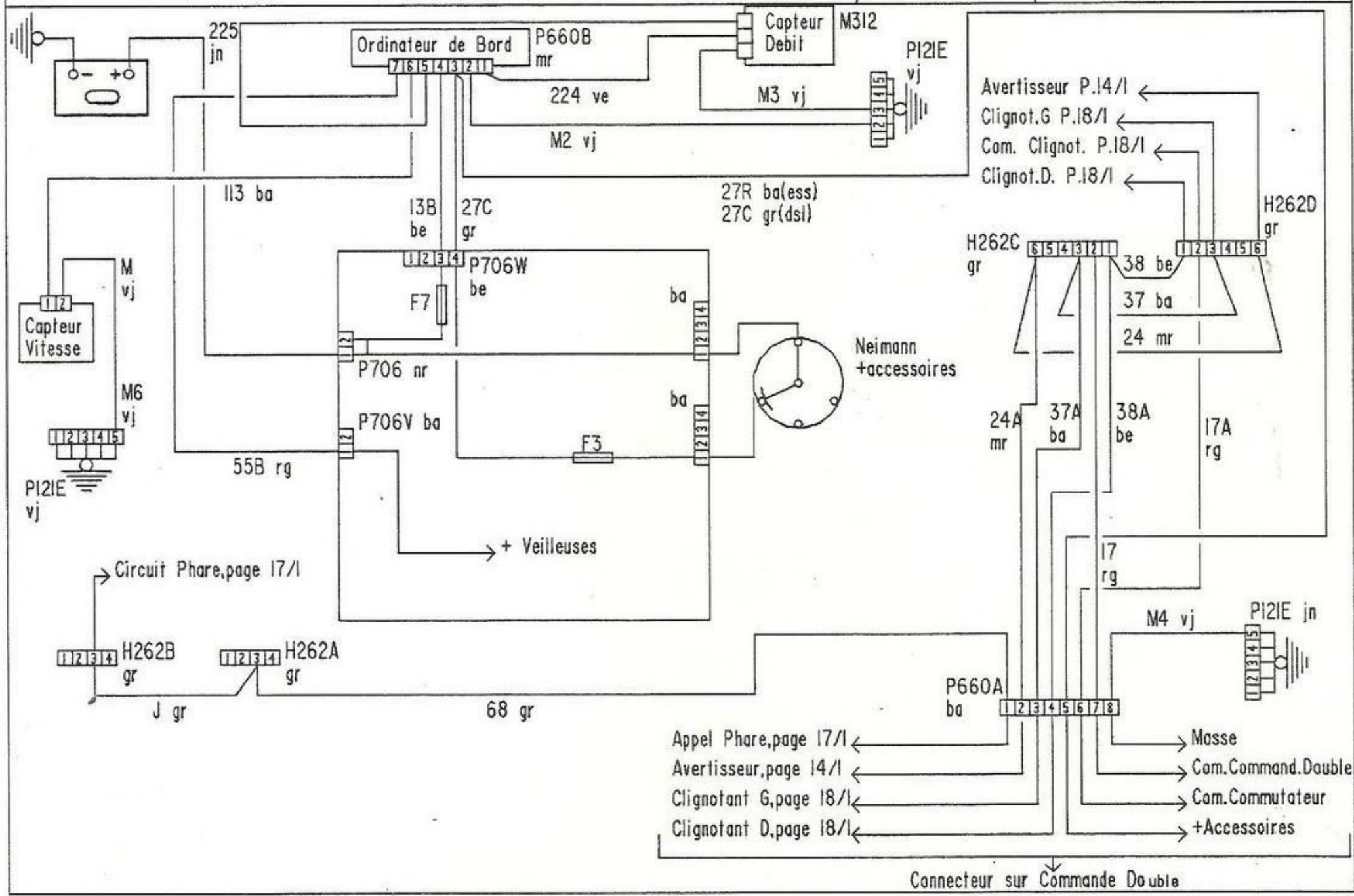

FONCTIONS PROTEGEES 44
PAR FUSIBLES 1

A JOUR LE: 20-06-85

NOM: VIGNES

TEL: 3162

FUSIBLES	INTENSITE	FONCTIONS
F1	10	Detecteur presence eau dans gasoil, Compte tours(gti), Feux de recul
F2	25	TEMOINS: Temp.Eau(gti), Freins(gti), Pression huile(gti), Niveau Eau(gti), Charge Batterie Presence Eau Dans Gasoil, Jauge(gti), Sieges chauff., Refri. Clignotants, Climatiseur
F3	25	TEMOINS: Temp.Eau(ess+dsl), Temp.Huile(dsl), Freins(ess+dsl), Niveau Eau(ess+dsl), Press. Huile(ess+dsl), Starter, EV AV, EV AR, Jauge Carb., Feux Stop, Lave Project., Compte Tours
F4		
F5	10	Signal danger
F6		
F7	25	Montre, Allume Cigare, Plafonnier Lecteurs Cartes, Aliment. Attache Remorque, +Permanent Auto Radio, Condamnation centralisee, Eclaireur de Coffre
F8	25	Avertisseur, Lunette Chauffante,
F9	20	Leves Vitre Electriques,
F10	5	Feu AR Brouillard,
F11	5	Feux de Position AR, Eclaireurs Plaque Police
F12	5	
F13	5 (10 en Suede)	Feux de Position AV, Eclairage Interrupteurs, Eclairage Facade+Combine
F14	15	Pompe Essence(gti)

BOITIER INTERCONNEXIONS

44/2

A JOUR LE: 20-06-85

NOM: VIGNES

TEL: 3162

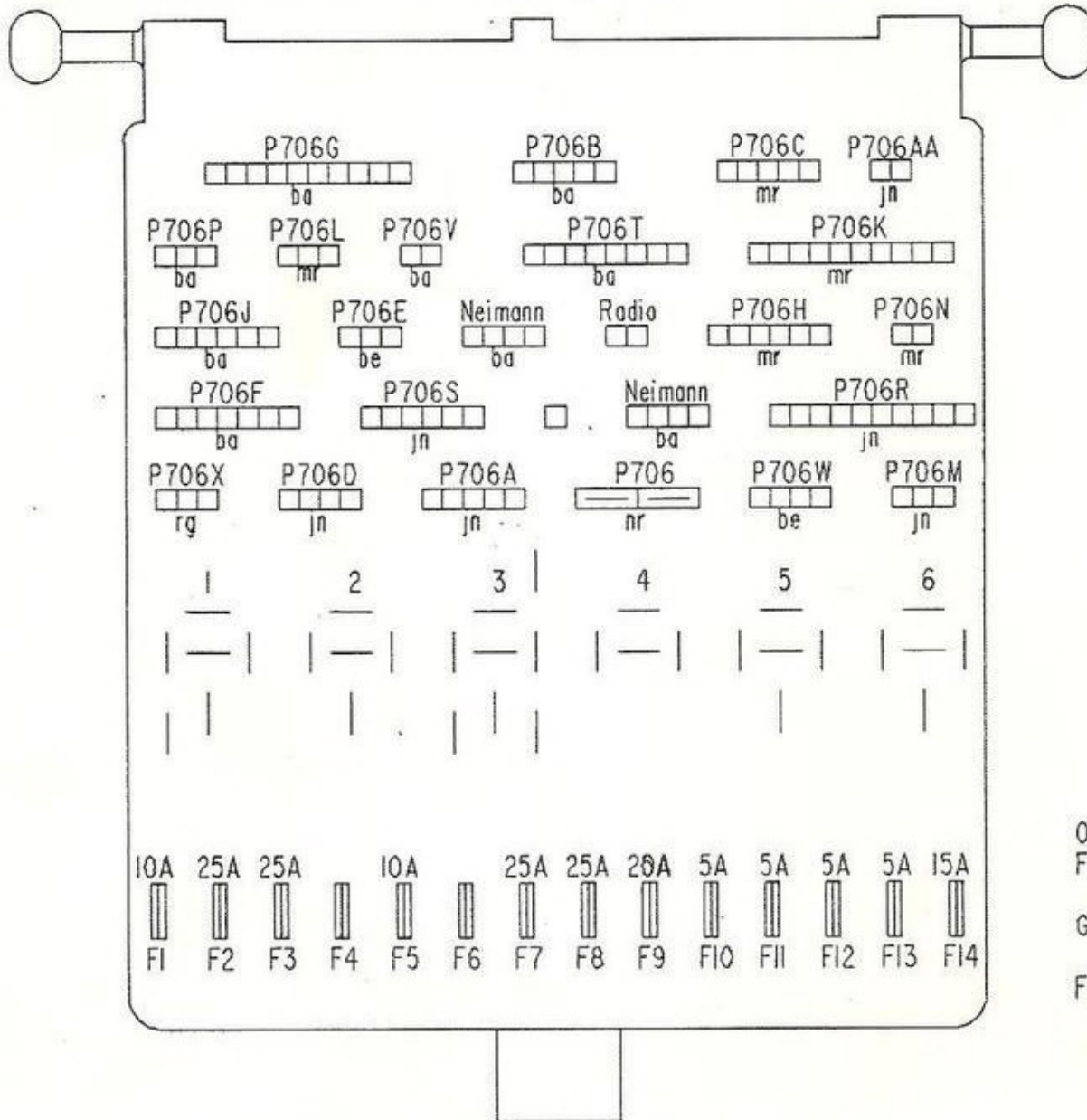

EMPLACEMENTS UTILISES:

- 1.
- 2.
3. TEMPO OU CONNECTEUR PONT
4. CENTRALE CLIGNOTANTE
5. RELAIS LEVE VITRES AV
6. RELAIS LUNETTE AR CHAUFFANTE
(Non Inverseur Imperativement)

TYPES	BOITIERS UTILISES
X GE	3(CONNECT.PONT)-4-6
X GL-GLD	3(CONNECT.PONT)-4-6
X GR-GRD	3(CONNECT.PONT)-4-6
SR-SRD	3(TEMPO)-4-6
X GT-GTI	3(TEMPO)-4-6

SAUF GHI
OU OPTION

OPTION LEVE VITRES ELECTRIQUES:
FUSIBLE F9 3(TEMPO)-4-5-6

GTI UNIQUEMENT: FUSIBLE F14 (POMPE ESSENCE)

F13=10A EN FEUX DIURNES

TYPES CONCERNES:
-205ESS
-205DSL

CONNECTEURS SUR BOITIER INTERCONNEX.

45

A JOUR LE: 20-06-85

NOM: VIGNES

TEL: 3162

P706G mr

10	9	8	7	6	5	4	3	2	1
151	53	48	49	36	64			107	

P706B ba

5	4	3	2	1
38	M56	56	JA	RA

P706C mr

5	4	3	2	1
37	RB	JB	55	M55
	RC	J2	55C	

2	1

RC, J2, 55C, en
GH114X seulement

P706P ba

3	2	1
106	107	

P706L mr

3	2	1
M2	M	

P706V ba

2	1
14A	55R

P706T ba

8	7	6	5	4	3	2	1
M29	48	50	29A	49	10	12	25B

P706K mr

10	9	8	7	6	5	4	3	2	1
	13	32	70		55A	RI		J1	SI
		32A							

32A Seulement en Finlande

P706J ba

6	5	4	3	2	1
M10B	34	25R	27A	33B	726

226 seulement avec
Sieges Chauffants
33E ala place de 226
avec Refrigeration

P706E be

3	2	1
57	2	
	57R	

57 en Diesel
57,57r en Refrig.

P706Y ba
Neimann

4	3	2	1
33R	35	32A	46

Seulement en DD
(Sans numero en DG)

P706U

29B	10C

P706H mr

6	5	4	3	2	1
70	35	16A		31	31A

P706N mr

2	1
16	M

P706F ba

7	6	5	4	3	2	1
		24	M47B	M6	87	

M47B en Diesel
seulement

P706S jn

6	5	4	3	2	1
61B	62A	28A	102	33C	31

P706Z mr
Neimann

4	3	2	1
1C			1

Seulement en DD
(Sans numero en DG)

P706R jn

10	9	8	7	6	5	4	3	2	1
	5	38	55		37	17	151	R	J

P706X rg

3	2	1
	10B	

Seulement en Option
Commande Centralisee

P706D jn

4	3	2	1
32F	52	53	46
52			46D

32F en GH1
14X seulement 46D en ESS GH1
14X seulement

P706A jn

5	4	3	2	1
	61	62	28B	31A

1A	1

P706W be

4	3	2	1
27B	13A	M3	92
27C	13B		92A

27C seulement
Auto Ecole
13B seulement
Auto Ecole Essence

P706M jn

3	2	1
23	24	55B

92
92A seulement avec
Option Leves Vitres

TYPE CONCERNE:
-205GTI

CONNECTEURS SUR
BOITIER INTERCONNEX.

45
2

A JOUR LE: 20-06-85

NOM: VIGNES

TEL: 3162

P706G mr

10	9	8	7	6	5	4	3	2	1
15R	53	48	49	36	64				107

P706B ba

5	4	3	2	1
38	56	56	JA	RA
		56A	68	

56A seulement en Espagne

68 en Tous Types sauf Espagne

P706C mr

5	4	3	2	1
37	88	88	55	M55
	RC	J2	55C	

RC, J2, 55C en GHI 14X seulement

P706AA jn

2	1
76A	76

P706P ba

3	2	1
106	107	

P706L mr

3	2	1
102		M

P706V ba

2	1
14A	55R

P706T ba

8	7	6	5	4	3	2	1
1029	48	50	29A	49	10	72	25B

P706K mr

10	9	8	7	6	5	4	3	2	1
		32	70		55A	R		J	

P706J ba

6	5	4	3	2	1
	1106	34	25R	27A	33B
					226

P706E be

3	2	1
	32A	2

P706Y ba Neimann

4	3	2	1
33R	33	32A	46

Seulement en DD
(Sans numero en DG)

P706U

29B	10C

P706H mr

6	5	4	3	2	1
70	35	16A			31
					31A

P706N mr

2	1
16	M

226 seulement avec Sieges Chauffants

P706F ba

7	6	5	4	3	2	1
		24		M7	M6	87

P706S jn

6	5	4	3	2	1
6B	62A	28A	102	33A	31

P706Z mr Neimann

4	3	2	1
1C			1

Seulement en DD
(Sans numero en DG)

P706R jn

10	9	8	7	6	5	4	3	2	1
	5	38	55		37	17	151	R	J

P706X rg

3	2	1
	108	

Seulement en Option Commande Centralisee

P706D jn

4	3	2	1
32B	52	53	46
32F			46D

32F, 46D en GHI 14X seulement

P706A jn

5	4	3	2	1
	61	62	28B	31A

P706 nr

1A	1

P706W be

4	3	2	1
27B	13A	M3	92
			92A

92, 92A seulement avec Option Leves Vitres

P706M jn

3	2	1
23	24	55B

TYPES CONCERNES:
-205ESS
-205DSL

CONNECTEURS SUR COMBINE

45/3

A JOUR LE: 20-06-85

NOM: VIGNES

TEL: 3162

PI65C ba
(Faisceau PdB)

1	2	3	4	5	6	7	8	9	10
70	51	14	M3	JI	RI	55A		13	

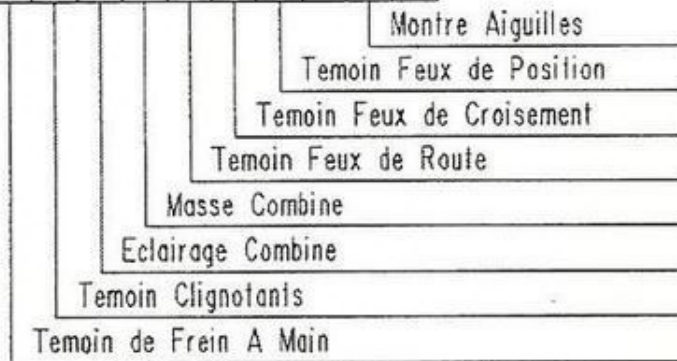

PI65 ve
(Faisceau PdB)

1	2	3	4	5	6	7	8	9
75	55A	65		55R		47M	32	

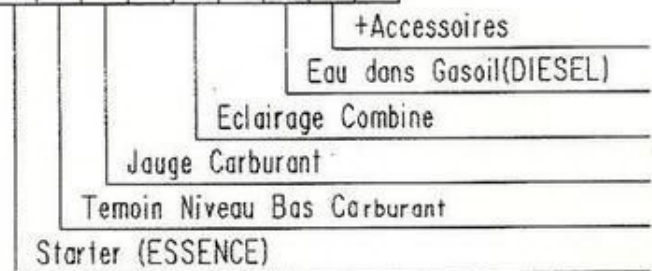

PI65B ba
(Faisceau Projecteur)

1	2	3	4	5	6	7	8
	30R	7A	73	47B	33B	69	112

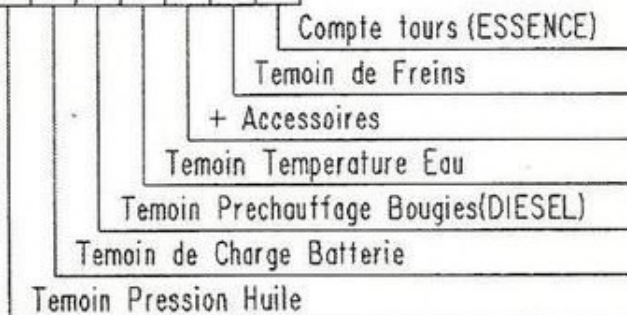

PI65D gr
(Faisceau projecteur)

1	2	3	4	5	6
50A	47				

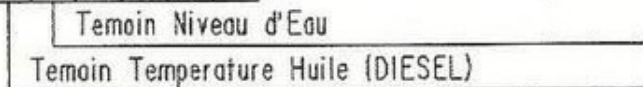

PI65D be
Faisceau PdR

1	2	3	4	5	6	7
7A		69A		37A	55R	RI

- Temoin Feux de Crois.
- Temoin Veilleuses
- Temoin Clignotant Gauche
- Temoin Niveau + Frein a Main
- Temoin de Charge Batterie

PI65 gr
Faisceau PdB

1	2	3	4	5	6	7	8
	30	69	J1		65	65A	

- Temoin Niveau Bas
- Jauge Carburant
- Temoin Feux Croisements
- Temoin Usure Plaquettes Freins
- Temoin de Pression Huile

PI65C ve
Faisceau PdB

1	2	3	4	5	6	7	8	9
		55A	14		32	47B	M3	38A

- Temoin Clignotant D
- Masse
- Temoin Niveau Eau
- +Accessoires
- Eclairage Combine
- Eclairage Combine

PI65B ba
Faisceau Projecteur

1	2	3	4	5	6	7	8	9	10
	30B		47		47A	30A			

- Recepteur Temperature Huile
- Recepteur Temperature Eau
- Temoin Temperature Eau
- Recepteur Pression Huile

PI65E be
Faisceau Projecteur

1	2	3	4
32B	1C	1B	
	141	112	

- Information Rupteur
- Masse + Blindage
- +Contact(Compte Tours)

NE FIGURENT SUR CETTE PAGE QUE LES CONNECTEURS INCOMPLETS POUR UNE SEULE ET MEME FONCTION

CONNECTEURS + INTERCONNEXIONS

45/5

ABREVIATIONS:

-FPRJ=FAISCEAU PROJECTEUR
-FAR=FAISCEAU FEUX AR

-FPOG=FAISCEAU PORTE AVG
-PDB=FAISCEAU PLANCHE DE BORD

-FPOD=FAISCEAU PORTE AVD
-FYAR=FAISCEAU VOLET AR

A JOUR LE: 20-06-85

NOM: VIGNES

TEL: 3162

FEU ARG
C445 mr

	1	2	3	4	5	6
FAR	151	48	49	64	36	53

COM. PHARES
H262B nr

	1	2	3	4
PdB	J	R	5	55
		150		150

↑ SUEDE

SOUS PDB G
PC3 ba

PdB	65	65A	28R	200A	201
	1	2	3	4	5
	1	2	3	4	5
FAR	65	65A	28R	200A	201
				201A	

SOUS PDB G
PC5 mr

PdB	94	96	200	201A
	1	2	3	4
	1	2	3	4
FPOG	94	96	200	201

FAR	107	M39
	1	2
	1	2
VAR	107	M39

CCI70 jn
FEU ARG

COM. EV.AV. AVEC INTERM.
H263 mr

	1	2	3	4	5	6	7
PdB	61	61A	31	28	62	33A	102
		33M				61A	

5 PORTES

FAR	87	
	28R	31A
	1	2
	1	2
VAR	28R	31A

CCI71 mr
FEU ARG

COM. EV.AV. SANS INTERM.
H263 mr

	1	2	3	4	5	6	7
PdB			31	28	62	33A	102
						33M	

SOUS PDB G
PC4 mr

				33A
PdB	47A	47M	6B	33C
	1	2	3	4
	1	2	3	4
PROJ	47A	47M	6B	33B

PdB	10B	92
	1	2
	1	2
FPOG	10B	92
		92B

SOUS PDB G
PC6 ba

FAR	200R	201B
	200A	201A
	1	2
	1	2
VAR	200	201

5 PORTES
3 PORTES
CCI72 ba
FEU ARG

COM. AVERT./CLIGNOT.
H262 nr

	1	2	3	4	5	6
PdB	22		24	38	17	37
				38A		37A

↑ (GTI)

SOUS PDB G
PC4 mr (GTI)

PdB	7A	47B	30	69	69A
	1	2	3	4	5
	1	2	3	4	5
PROJ	7A	47B	30R	69C	69A
				69B	

SOUS PDB D
PC7 ba

PdB	92A	94	96	201A	200
	1	2	3	4	5
	1	2	3	4	5
FPOD	92A	94	96	201	200

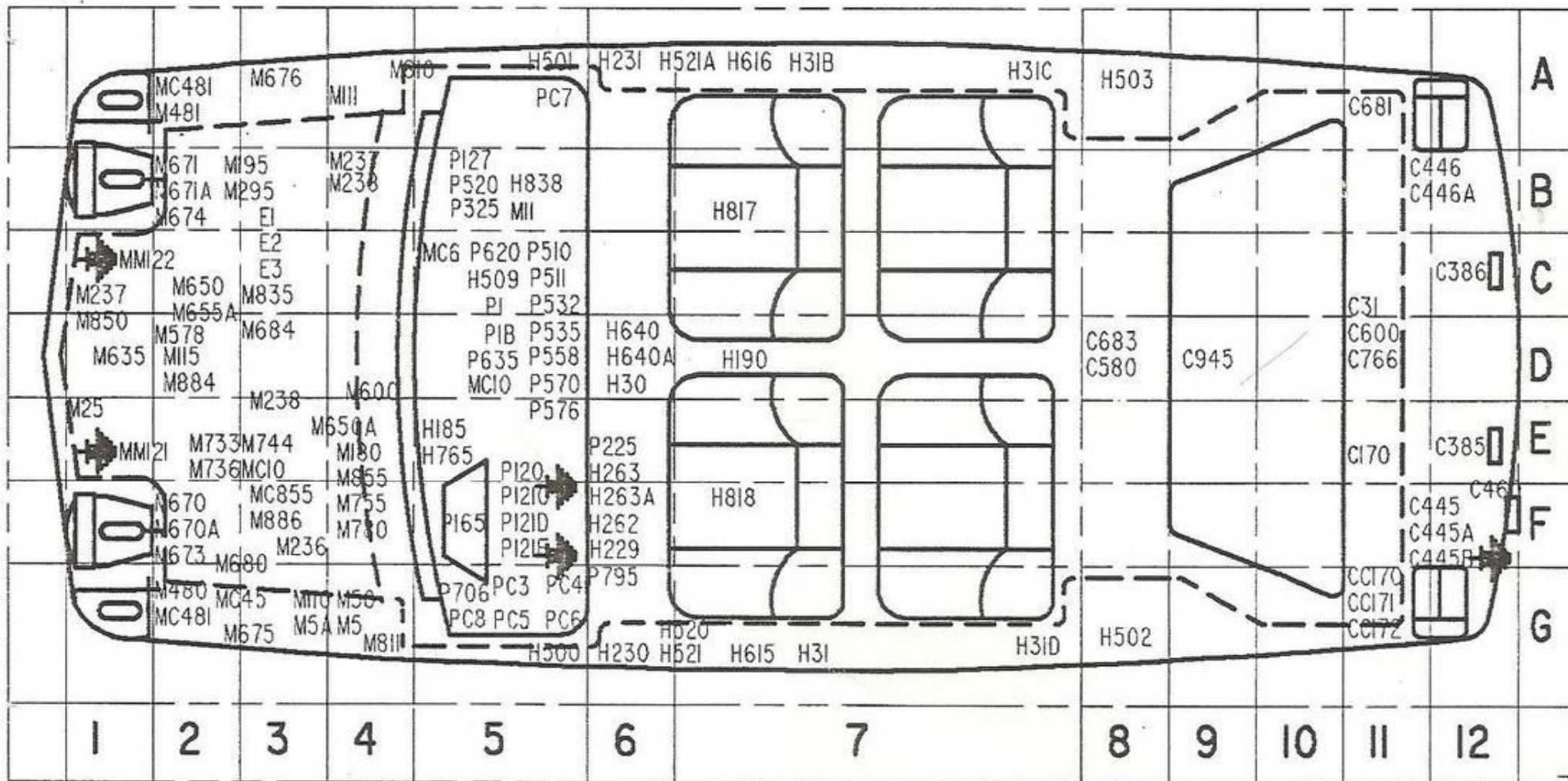

NUMERO DE L'APPAREIL
EMPLACEMENT DE L'APPAREIL
DESIGNATION DE L'APPAREIL

IMPLANTATION CONNECTEURS

46
2

A JOUR LE: 20-06-85

NOM: VIGNES

TEL: 3162

C31	CII	ACTION. VOLET COFFR.	H616	A7	MOT. LEVE VITR. AVD	M680	G3	POMPE EV AV	CCI70	GII	INTERCONNEXION
CI70	EII	CONT. ECLAIR. COFFR.	H640	D6	MONTRE	M684	D3	POMPE ESS. PROJECT.	CCI71	GI1	INTERCONNEXION
C385	EI2	ECL. PLAQ. POL.G	H640A	D6	MONTRE	M733	E2	RELAIS MOTOVENTILAT.	CCI72	GI1	INTERCONNEXION
C386	CI2	ECL.PLAQ. POL. D	H765	E5	RELAIS EV AV	M736	E2	REL. LONGUE PORTEE	MC6	C5	INTERCONNEXION
C445	F12	FEU ARG	H817	B7	SIEGE CHAUFF. AVD	M744	E3	REL. TACHYMETR.	MC10	E3	INTERCONNEXION
C445A	F12	FEU ARG	H818	F7	SIEGE CHAUFF. AVG	M755	F4	REL. ESS. PROJECT.	MC10	D5	INTERCONNEXION
C445B	F12	FEU ARG	H838	B5	THERM. REFRI	M780	F4	REL. FEUX DIURNES	MC45	G3	INTERCONNEXION
C446	BI2	FEU ARD	M5	G4	ALLUMEUR	M810	A4	REP. LATER. D	MC481	A2	INTERCONNEXION
C446A	BI2	FEU ARD	M5A	G5	ALLUMEUR	M811	G4	REP. LATER. G	MC855	F3	INTERCONNEXION
C460	F12	FEU AR BROUILLARD	MII	B5	MODULE CLIMATIS.	M850	DI	THERMOC. RADIAT.	MMI21	E1	MASSE/ARMATURE AVG
C580	D8	JAUGE CARBURANT	M25	E1	AVERTISSEUE	M884	D2	TIROIR AIR	MMI22	CI	MASSE/ARMATURE AVD
C600	DII	MOTEUR EV AR	M50	G4	BOBINE	M886	F3	SONDE TEMP. EAU	PC3	G5	INTERCONNEXION
C681	AII	POMPE LV AR	MII0	G3	BOITIER PRECHAUFF.	PI	C5	ALL.CIGARE	PC4	G5	INTERCONNEXION
C683	D8	POMPE ESSENCE GTI	MIII	A4	BOIT. COUP. DECELER.	PIB	D5	ECL. ALL. CIGARE	PC5	G5	INTERCONNEXION
C766	DII	RELAIS EV AR	MII5	D2	BOUGIES PRECHAUFF.	PI20	E5	BORNE DE RACCORD.	PC6	G5	INTERCONNEXION
C945	G8	VITRE AR CHAUFFANTE	M180	E4	INTER. FEUX RECU	PI27	B5	CALCULATEUR GTI	PC7	A5	INTERCONNEXION
E1	B3	EPISS./FAISC. INJECT.	M195	B3	BASSE PRESS. FREON	PI2IC	F5	MASSE	PC8	G5	INTERCONNEXION
E2	C3	EPISS./FAISC. INJECT.	M236	F3	CONT. LIQU. FREIN	PI2IID	F5	MASSE			
E3	C3	EPISS./FAISC. INJECT.	M237	B4	NIVEAU EAU	PI2IE	F5	MASSE			
H30	D6	AUTORADIO	M238	B4	PRES. EAU/GAS-OIL	PI65	F5	COMBINE			
H31	G7	ACTION. PORTE AVG	M238	D3	CONTACT. PAPIL(GTI)	P225	E6	CONT. TEM. STARTER			
H31B	A7	ACTION. PORTE AVD	M295	B3	COMPRESSEUR REFRI.	P325	B5				
H31C	A7	ACTION. PORTE ARD	M293	A3	COMPRESSEUR TROMPES	P510	C5	INTER. FEU AV BROUIL			
H31D	G7	ACTION. PORTE ARG	M480	G2	CLIGNOT. AVG	P511	C5	INTER. FEU AR BROUIL			
H185	E5	CONTACTEUR STOP	M481	G2	CLIGNOT. AVD	P520	B5	CONN. LEVE VITRE			
H190	D7	CONTACT. FREIN MAIN	M578	D2	INJECTEURS	P532	C5	INTER. VIT. AR CHAUF.			
H229	F6	ANTIVOL	M600	D4	MOTEUR EV AR	P535	D5	INTER. SIEG. CHAUFF.			
H230	G6	CONTACT. FEUILL. AVG	M635	DI	MOTOVENTILATEUR	P558	D5	INTER. CLIMAT.			
H231	A6	CONTACT. FEUILL. AVD	M650	C2	MANO HUILE	P570		INTER. SIGN. DANGER			
H262	F6	COMMUT. ECLAIR.	M650A	E4	THERM. TEMP. HUILE	P576	E5	INTER. REFRI			
H263	F6	COMMUT. EV	M655A	C2	MANO HUILE	P620	C5	MOTEUR CLIMATIS.			
H263A	F6	COMMUT. EV	M670	F2	PROJECT. AVG	P635	D5				
H500	G5	HP AVG	M670A	F2	PROJECT. AVG	P706	G5	BOITIER INTERCONN.			
H501	A5	HP AVD	M671	B2	PROJECT.AVD	P795	G6	RHEOST. ECLAIRAGE			
H509	C5	THERMOSTAT REFRI	M671A	B2	PROJECT. AVD						
H520	G7	INT. LEVE VITR. COND.	M673	F2	LONGUE PORTEE AVG						
H521	G7	INT. LEVE VITR. PASS.	M674	B2	LONGUE PORTEE AVD						
H521A	A7	INT. LEVE VITR. PASS.	M675	G3	PLAQUETTE AVG						
H615	G7	MOT. LEVE VITR. AVG	M676	A3	PLAQUETTE AVD						